



GM Multi-kit 2004-Up

KIT FEATURES

- ISO DIN radio provision with pocket
- ISO DDIN radio provision

KIT COMPONENTS

- A) Radio housing A • B) Radio brackets • C) Radio housing B • D) Pocket • E) #8 x 3/8" Phillips screws (4)

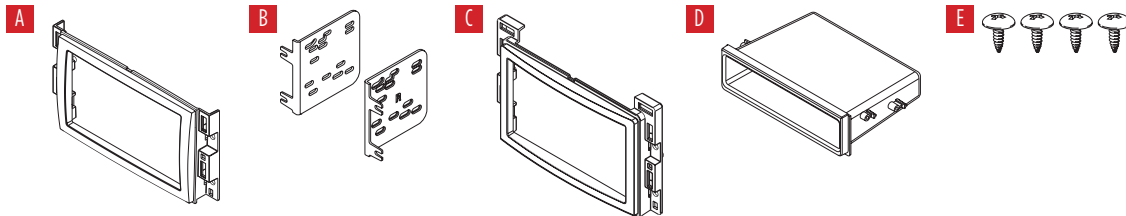

APPLICATIONS

See inside front cover

TABLE OF CONTENTS

See inside front cover

TOOLS REQUIRED

- Panel removal tool
- Phillips screwdriver
- 7mm & 10mm socket wrench
- Torx driver
- Allen wrench
- Cutting tool

WIRING & ANTENNA CONNECTIONS SOLD SEPARATELY

ATTENTION: With the key out of the ignition, disconnect the negative battery terminal before installing this product. Ensure that all installation connections are secure before cycling the ignition to test this product.
NOTE: Refer to the instructions included with the aftermarket radio.

APPLICATIONS

Radio Housing A

Buick

Enclave	2008-2012
Lucerne	2006-2011

Chevrolet

Avalanche	2007-2013
Equinox	2007-2009
Express	2008-up
Impala	2006-2013
Impala Limited (Fleet)	2014
Monte Carlo	2006-2007
Silverado**	2007-2013
Silverado 2500/3500	2014
Suburban	2007-2014
Tahoe	2007-2014
Traverse	2009-2012
Captiva Sport	2012-2015

GMC

Acadia	2007-2012
Savana	2008-up
Sierra**	2007-2013
Sierra 2500/3500	2014
Yukon	2007-2014

Hummer

H2	2008-2009
----------	-----------

Pontiac

Torrent	2007-2009
---------------	-----------

Saturn

Outlook	2007-2010
Vue	2008-2010

Suzuki

XL-7	2007-2009
------------	-----------

***Excluding classic models*

Radio Housing B

Chevrolet

Cobalt	2005-2010
Equinox	2005-2006
HHR	2006-2011
Malibu	2004-2007
Malibu	2008-2012

Pontiac

G5	2007-2009
G6	2005-2010
Solstice	2006-2009
Torrent	2006

Saturn

Aura	2007-2009
Ion	2006-2007
Sky	2007-2009
Vue	2006-2007

TABLE OF CONTENTS

Dash Disassembly

- Buick Enclave 2008-2012	16	- GMC Savana 2008-Up	13
- Buick Lucerne 2006-2011	12	- GMC Sierra (excl. classic models) 2007-2013 ...	12
- Chevrolet Avalanche 2007-2013	12	- GMC Sierra 2500/3500 2014	12
- Chevrolet Captiva Sport 2012-2015	17	- GMC Yukon 2007-2014	12
- Chevrolet Cobalt 2005-2010	3	- Hummer H2 2008-2009	17
- Chevrolet Equinox 2005-2006	4	- Pontiac G5 2007-2009	3
- Chevrolet Equinox 2007-2009	15	- Pontiac G6 2005-2010	7
- Chevrolet Express 2008-Up	13	- Pontiac Solstice 2006-2009	8
- Chevrolet HHR 2006-2011	4	- Pontiac Torrent 2006	4
- Chevrolet Impala 2006-2013	12	- Pontiac Torrent 2007-2009	15
- Chevrolet Impala Limited (Fleet) 2014	12	- Saturn Aura 2007-2009	9
- Chevrolet Malibu 2004-2007	5-6	- Saturn Ion 2006-2007	9
- Chevrolet Malibu 2008-2012	6-7	- Saturn Outlook 2007-2010	16
- Chevrolet Monte Carlo 2006-2007	12	- Saturn Sky 2007-2009	10
- Chevrolet Silverado Pickup (excluding classic models) 2007-2013	12	- Saturn Vue 2006-2007	11
- Chevrolet Silverado 2500/3500 2014	12	- Saturn Vue 2008-2010	17
- Chevrolet Suburban 2007-2014	12	- Suzuki XL-7 2007-2009	14
- Chevrolet Tahoe 2007-2014	12		
- Chevrolet Traverse 2009-2012	16		
- GMC Acadia 2007-2012	16		

Kit Assembly

- ISO DIN radio provision with pocket	18
- ISO DDIN radio provision	19

DASH DISASSEMBLY

Chevrolet Cobalt 2005-2010 Pontiac G5 2007-2009

1. Unclip and remove trim panel from above glove box. (Figure A)
2. Unclip the upper edge of the panel below the steering column and let hang. (Figure B)
Note: It is not necessary to remove the panel.
3. Unclip and remove the small trim panel to the right of the ignition switch. (Figure C)
4. Using the panel removal tool, unclip and remove the trim panel surrounding the factory radio, including the climate controls. (Figure D)
5. Remove (4) 9/32" screws securing the factory radio, disconnect the wiring, and then remove the radio. (Figure E)

Continue to Kit Assembly



(Figure A)

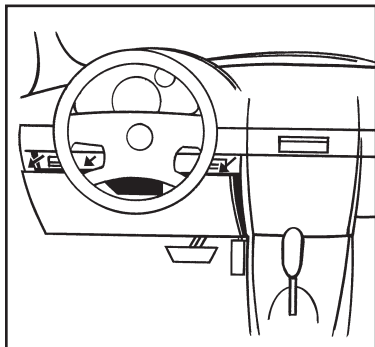

(Figure B)

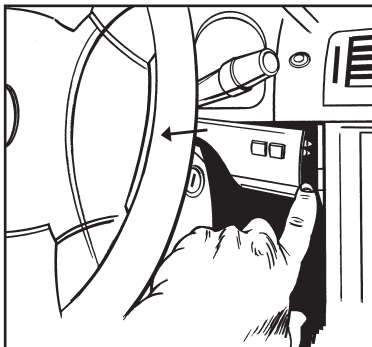

(Figure C)



(Figure D)

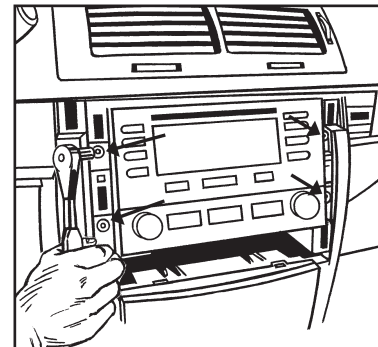

(Figure E)

DASH DISASSEMBLY

Chevrolet Equinox 2005-2006 Pontiac Torrent 2006

1. On the center console, unsnap the panel below the power window switch. Remove the panel and unplug the window switch. (Figure A)
2. Using the panel removal tool, unclip and remove the entire panel surrounding the factory radio and gear shifter. (Figure B)
3. Remove (4) 9/32" screws securing the factory radio, disconnect the wiring, and then remove the radio. (Figure C)

Continue to Kit Assembly

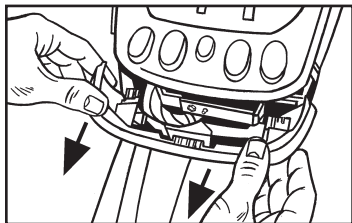

(Figure A)

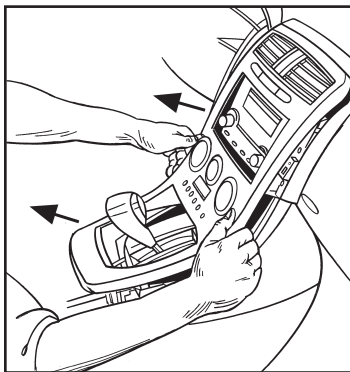

(Figure B)

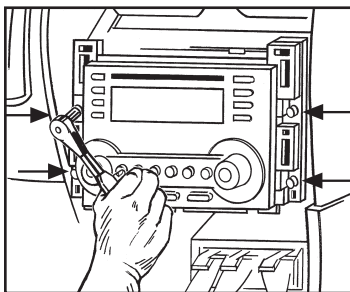

(Figure C)

Chevrolet HHR 2006-2011

1. Using the panel removal tool, unclip and remove the entire panel surrounding radio and climate controls, including the A/C vents. (Figure A)
2. Remove (8) 9/32" screws securing the factory radio and A/C control, disconnect the wiring, and then remove radio/ climate control assembly. (Figure B)

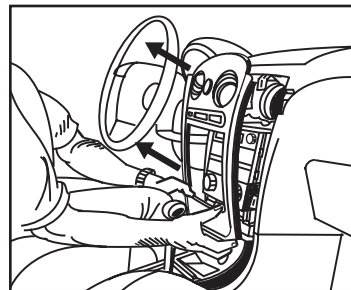

(Figure A)

Continue to Kit Assembly

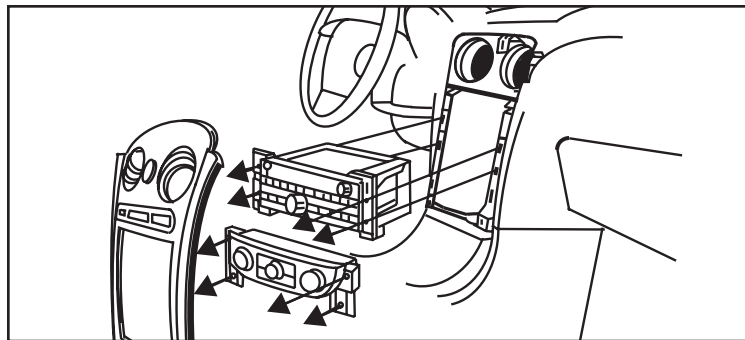

(Figure B)

DASH DISASSEMBLY

Chevrolet Malibu 2004-2007

1. Using the panel removal tool, carefully unclip and remove the wood grain/painted trim pieces from both sides of the steering wheel. (Figure A)
2. With the door open, unclip and remove the driver's side panel and remove (2) 7mm screws. (Figure B)
3. Remove (2) 7mm screws from the bottom edge of the steering wheel panel, unclip the panel and let hang. Note: It is not necessary to completely remove panel. (Figure C)
4. Using the panel removal tool, gently unclip and remove the wood grain/painted trim piece from above the glove box. (Figure D)

Continue on next page

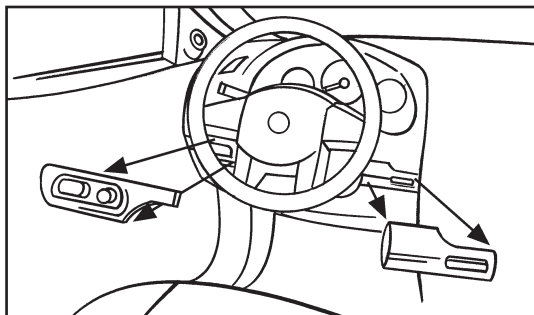

(Figure A)

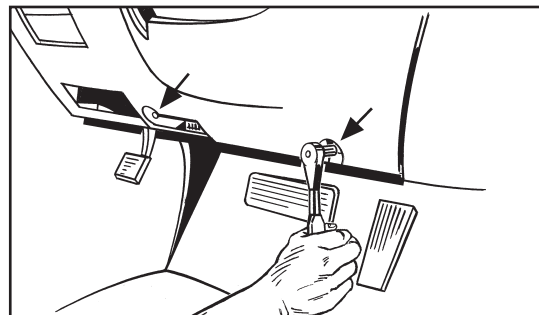

(Figure C)

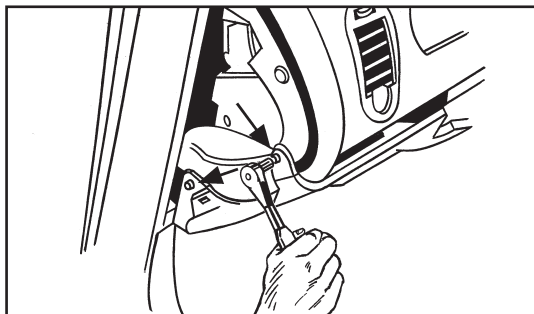

(Figure B)

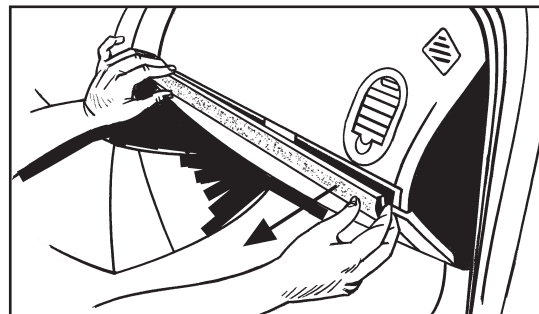

(Figure D)

DASH DISASSEMBLY

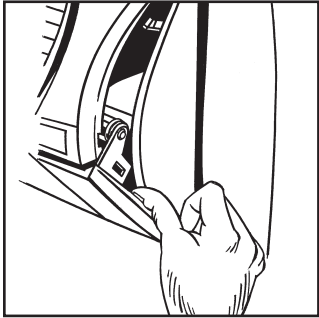

(Figure E)

Chevrolet Malibu 2004-2007 (Cont.)

5. With the door open, unclip and remove the passenger's side panel and remove (2) 7mm screws from behind the panel. (Figure E)
6. Remove (2) 7mm screws from the bottom of the glove box, then squeeze the sides together to open further and remove the remaining (4) 7mm screws. Pull out the black vent cover under the glove box, then unclip and remove the entire glove box assembly. (Figure F)
7. Using the panel removal tool, carefully unclip and remove the trim panel surrounding radio and climate controls. (Figure G)
8. Remove (4) 7mm screws securing the radio and (2) 7mm screws securing the climate control, unplug and remove the assembly. (Figure H)

Continue to Kit Assembly

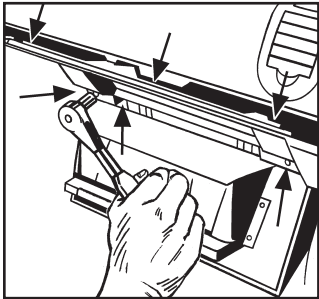

(Figure F)

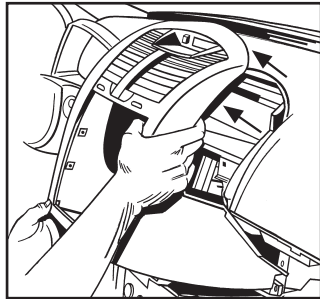

(Figure G)

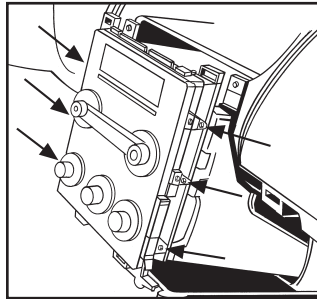

(Figure H)

Chevrolet Malibu 2008-2012

1. Unsnap and remove shifter trim. (Figure A)
Note: Start around shifter and be sure to pull down before back because this panel slides up under the radio/climate panels.
2. Remove (2) 8mm screws from bottom of radio/climate panel.
3. Unsnap and remove the climate/radio panel and upper vent trim panel together. They can be separated after removal. (Figure B, C next page)
4. Remove (6) 8mm screws from radio and climate controls.

Continue to Kit Assembly

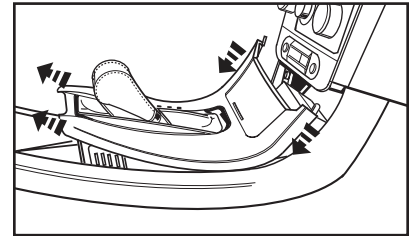

(Figure A)

DASH DISASSEMBLY

Chevrolet Malibu 2008-2012 (Cont.)

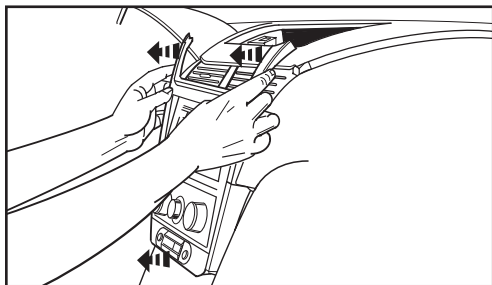

(Figure B)

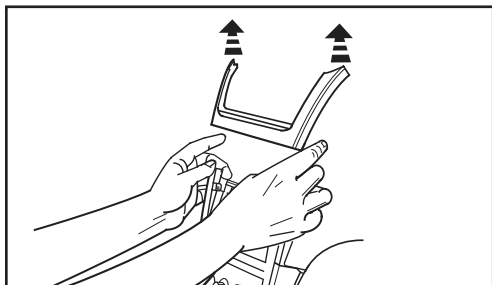

(Figure C)

Pontiac G6 2005-2010

1. Open the glove box and remove (6) 7mm screws from the outer edge, and then unclip and remove the glove box. (Figure A)
2. Remove (4) 7mm screws from the panel below the steering column, and then unclip and remove the panel. (Figure B)
3. Unclip and remove the center panel surrounding the radio and climate controls. (Figure C)
4. Remove (4) 7mm screws securing the factory radio, disconnect the wiring, and then remove the radio. (Figure D)

Continue to Kit Assembly

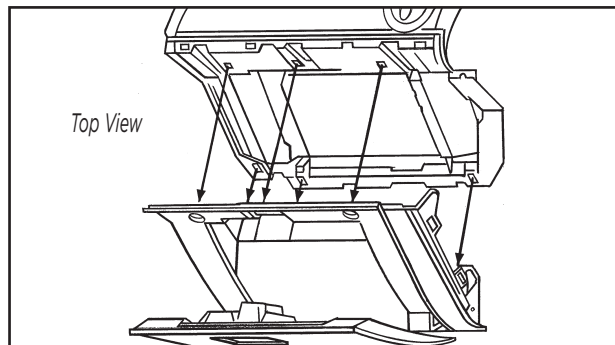

(Figure A)

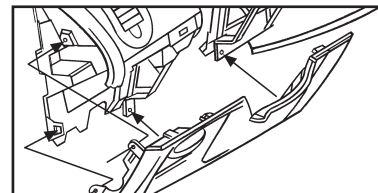

(Figure B)

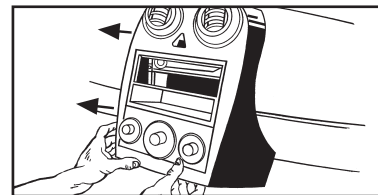

(Figure C)

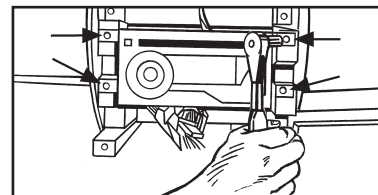

(Figure D)

DASH DISASSEMBLY

Pontiac Solstice 2006-2009

1. (A) Manual transmission:

Lift up the lower edge of the instrument panel cluster trim plate enough to reach underneath and release the shift boot trim ring retaining tabs. (Figure A)

Lift up on the shift boot and loosen the setscrew to release the shift lever. (Figure B)

1. (B) Automatic transmission:

Unclip and remove shifter trim ring. (Figure C)

2. Unclip and remove passenger assist handle trim panel. (Figure D)
3. Remove (2) bolts securing the passenger assist handle and remove handle. (Figure D)
4. Unclip and remove dash trim panel.
5. Remove (4) screws securing the radio. Unplug and remove the radio.

Continue to Kit Assembly

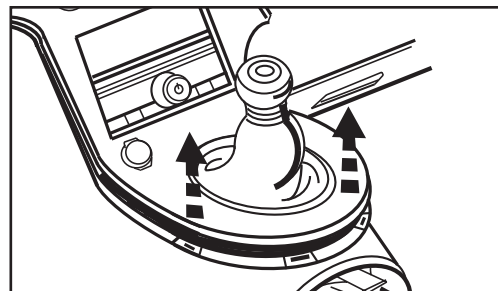

(Figure A)

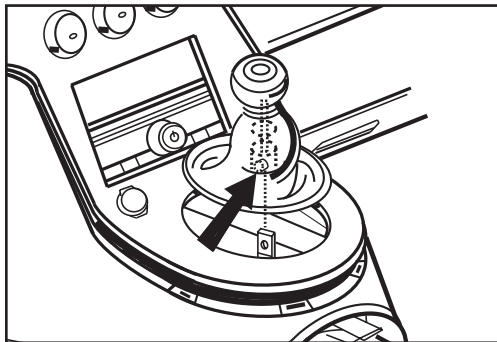

(Figure B)

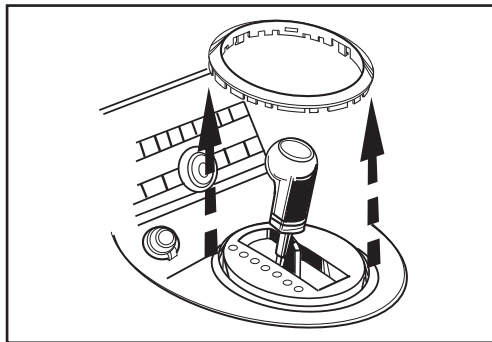

(Figure C)

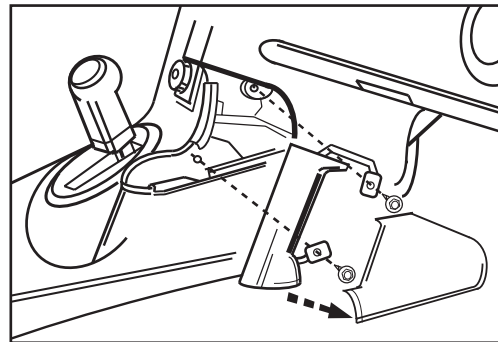

(Figure D)

DASH DISASSEMBLY

Saturn Aura 2007-2009

1. Unclip and remove the shifter trim ring. (Figure A)
2. After shifting to neutral, unclip and remove the center console trim panel, and then remove (2) 7mm screws from the bottom edge of the dash trim panel. (Figure B)
3. Beginning on the passenger's side, carefully unclip and remove the dash trim panel. (Figure C)
Note: The key switch trim ring will unclip with the panel.
4. Remove (2) 7mm screws securing the climate controls.
Note: The climate controls do not have to be removed.
5. Remove (4) 7mm screws securing the factory radio, disconnect the wiring, and then remove the radio.

Continue to Kit Assembly

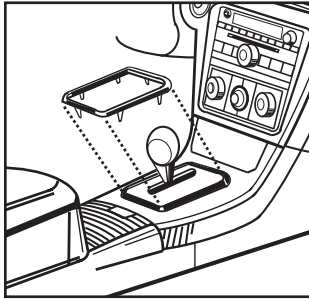

(Figure A)

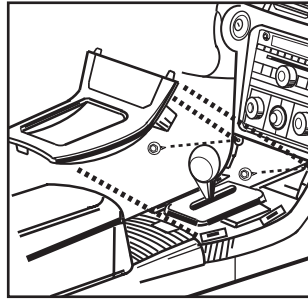

(Figure B)

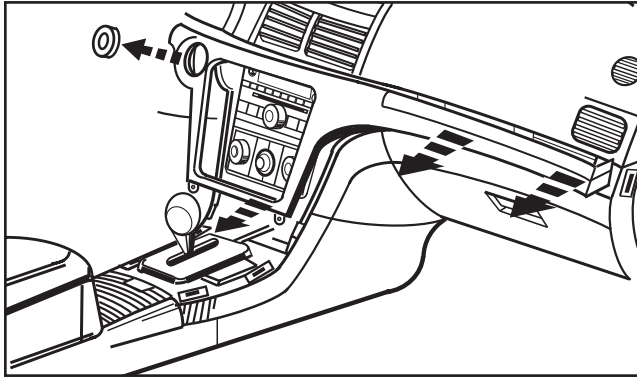

(Figure C)

Saturn Ion 2006-2007

1. Using the panel removal tool, carefully unclip the radio trim panel. (Figure A)
2. Unplug the connectors and remove the radio trim panel. (Figure B)
3. Remove (4) 7mm screws securing the factory radio, disconnect the wiring, and then remove the radio.

Continue to Kit Assembly

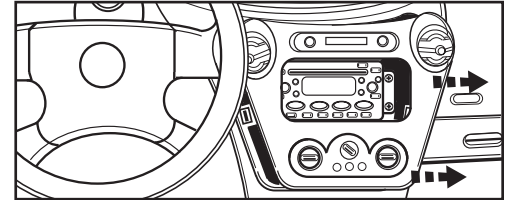

(Figure A)

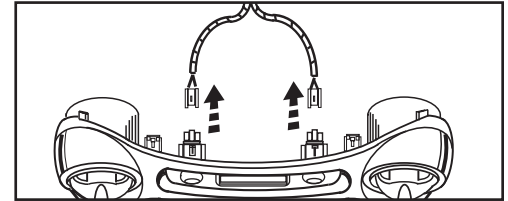

(Figure B)

DASH DISASSEMBLY

Saturn Sky 2007-2009

1. With the driver's side door open, unclip and remove the driver's side panel and remove (2) 7mm screws. (Figure A)
2. Remove (2) 7mm screws from the bottom edge of the panel below the steering wheel, unclip and remove the panel.
3. With the passenger's side door open, unclip and remove the passenger's side panel and remove (2) 7mm screws from behind the panel. (Figure B)
4. Open the glove box and disconnect the glove box dampener from the glove box assembly. Squeeze the sides together to open further. (Figure C)
5. Remove (2) bolt covers from top edge of glove box frame. (Figure C)
6. Remove (5) 7mm bolts from the glove box frame and remove the frame. (Figure C)
7. Using the panel removal tool, carefully unclip and remove the radio/climate control trim panel. (Figure D)
8. Remove (1) 7mm screw from the lower left corner of radio trim panel and unplug the connectors to remove the panel. (Figure D)
9. Remove (4) 7mm screws securing the factory radio, disconnect the wiring, and then remove the radio.

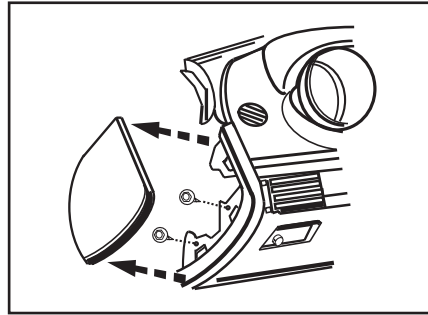

(Figure A)

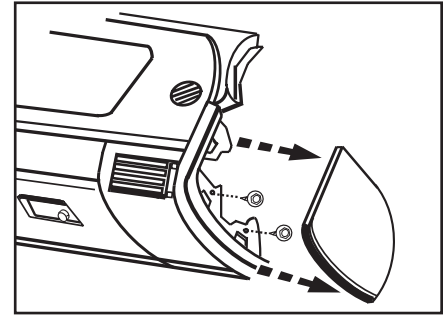

(Figure B)

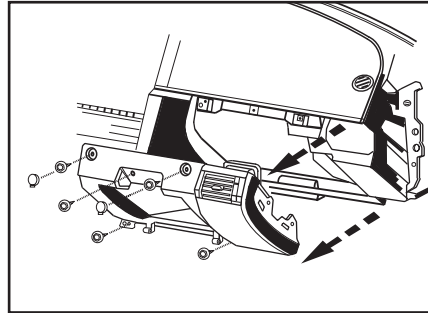

(Figure C)

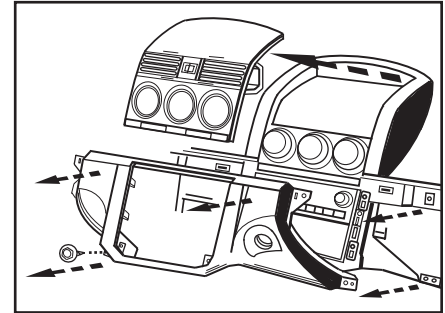

(Figure D)

Continue to Kit Assembly

DASH DISASSEMBLY

Saturn Vue 2006-2007

1. Grasp the front edge of the shifter trim panel and pull outward and upward. (Figure A)
2. Squeeze the locking tabs located at the front edge of the shifter trim panel together to release the front edge of the panel from the center console. (Figure B)
3. Pull upward on the panel to release the remaining clips, and remove the entire trim panel.
4. Remove (4) 7mm screws securing the storage pocket and remove the pocket. (Figure C)
5. Using the panel removal tool, carefully unclip and remove the center dash trim panel. (Figure D)
6. Remove (4) 7mm screws securing the factory radio, disconnect the wiring, and then remove the radio.

Continue to Kit Assembly

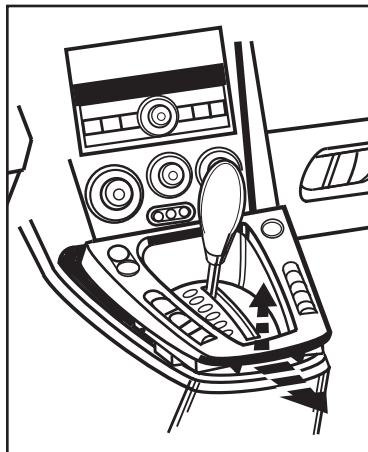

(Figure A)

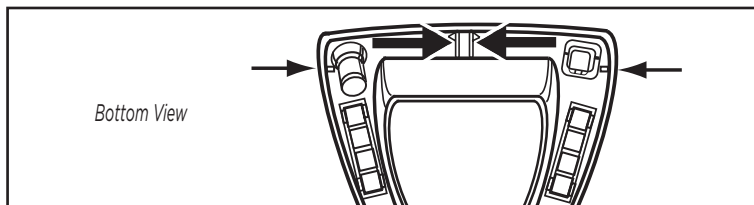

(Figure B)

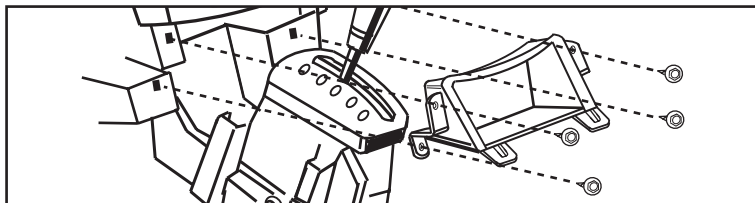

(Figure C)

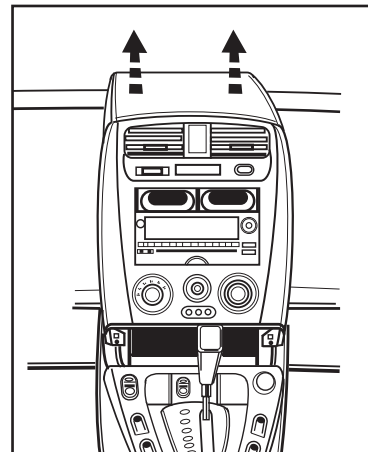

(Figure D)

DASH DISASSEMBLY

**Buick Lucerne 2006-2011 /
Chevrolet Impala 2006-2013, Impala Limited (Fleet) 2014,
Monte Carlo 2006-2007**

1. Using the panel removal tool, carefully unclip and remove the trim panel around radio and climate control. (Figure A)
2. Remove (6) 7mm screws securing the factory radio and climate control to the dash, disconnect the wiring, and then remove the assembly. (Figure B)

Continue to Kit Assembly

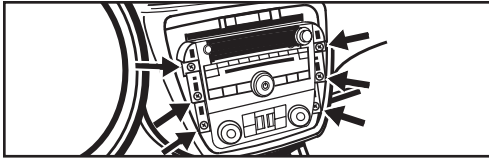

(Figure A)

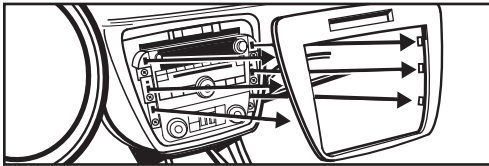

(Figure B)

Chevrolet Avalanche 2007-2013, Silverado (excluding classic models) 2007-2013, Tahoe/Suburban 2007-2014, Silverado 2500/3500 2014 GMC Yukon 2007-2014, Sierra (excluding classic models) 2007-2013, Sierra 2500/3500 2014

1. Unclip and remove radio trim panel. (Figure A)
2. Remove (2) 7mm screws securing switch panel below climate controls. Unplug and remove switch panel. (Figure B)
3. Remove (2) 7mm screws securing climate controls. Unplug and remove climate controls. (Figure B)
4. Remove (4) 7mm screws securing radio. Unplug and remove the radio. (Figure C)

Continue to Kit Assembly

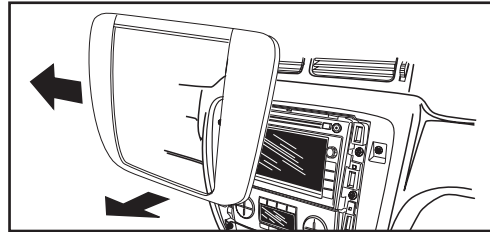

(Figure A)

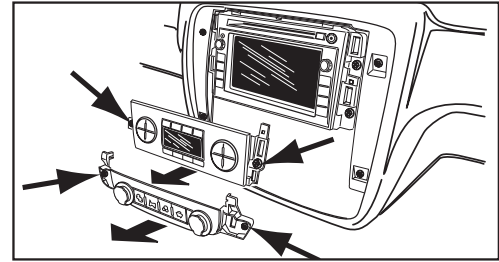

(Figure B)

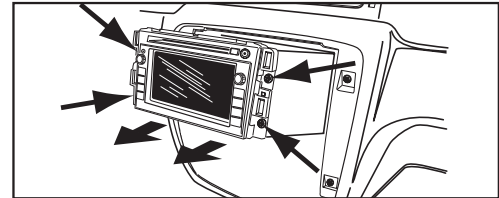

(Figure C)

DASH DISASSEMBLY

Chevy Express GMC Savana 2008-Up

1. Remove (2) 10mm bolts from below the knee bolster under the steering column and remove the panel. (Figure A)
2. Remove (2) 10mm bolts from the panel below the passenger dash airbag, and remove the panel. (Figure B)
3. Using the panel removal tool, carefully unclip and remove the radio/instrument cluster panel. (Figure C)

Note: To access the factory radio, it may not be necessary to completely remove the radio and instrument cluster panel.

4. Remove (4) 7mm bolts securing the factory radio, disconnect the wiring, and then remove the radio. (Figure D)

Continue to Kit Assembly

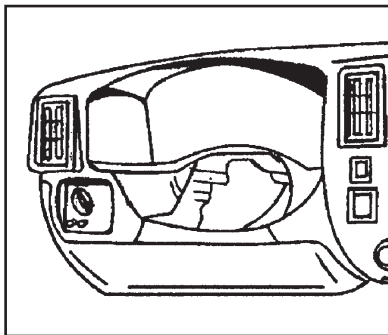

(Figure A)

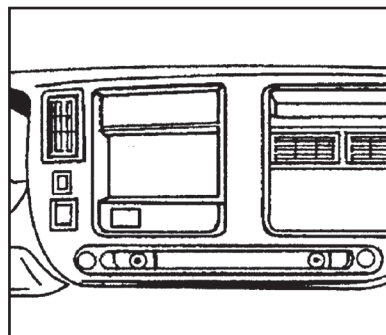

(Figure C)

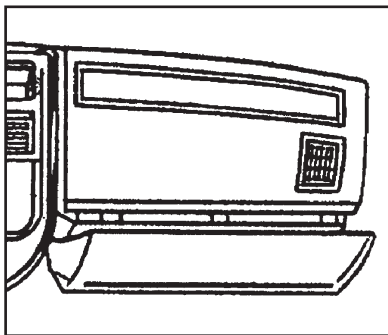

(Figure B)

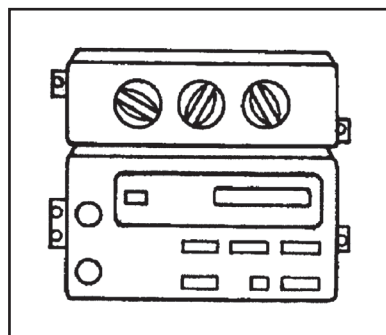

(Figure D)

DASH DISASSEMBLY

Suzuki XL-7 2007-2009

1. Press in on the sides of the shifter boot to release it from the shifter trim panel. (Figure A)
2. Lift the boot up to access (1) Allen screw securing the shifter knob to the shifter lever. Loosen the Allen screw and remove the shifter knob. (Figure B)
3. Remove (1) Torx screw from the shifter trim panel. (Figure C)
4. Using the panel removal tool, unsnap, unplug and remove the shifter trim panel. (Figure D)
5. Using the panel removal tool, gently unclip, unplug and remove the radio trim panel. (Figure E)
6. Remove (4) 7mm screws securing the radio, disconnect the wiring, and then remove the radio.

Continue to Kit Assembly

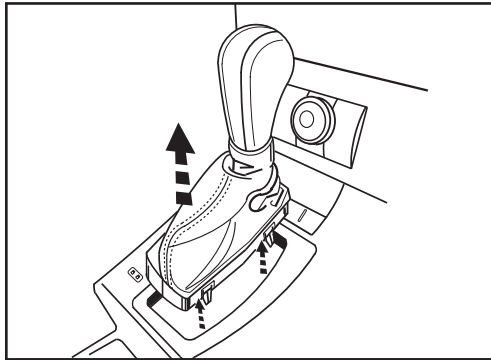

(Figure A)

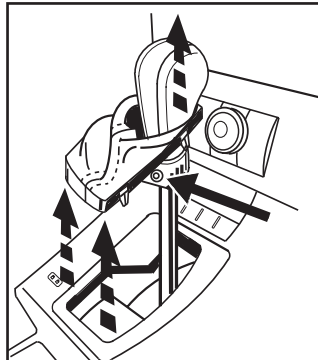

(Figure B)

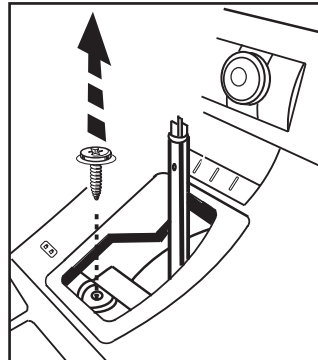

(Figure C)

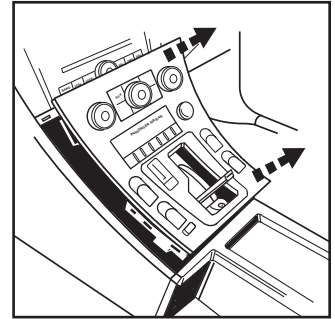

(Figure D)

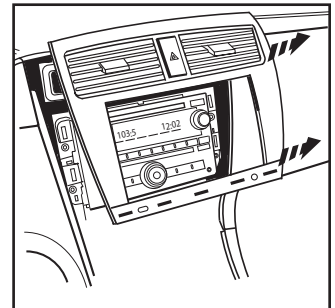

(Figure E)

DASH DISASSEMBLY

Chevy Equinox/Pontiac Torrent 2007-2009

1. Unsnap and pull out the panel below the power window switch. (Figure A)
Note: This allows you to gain access to the power window switch.
2. Using the panel removal tool, carefully unclip and remove the entire panel surrounding the radio and gear shifter. (Figure B)
3. Remove (4) 7mm screws securing the factory radio, disconnect the wiring, and then remove the radio. (Figure C)

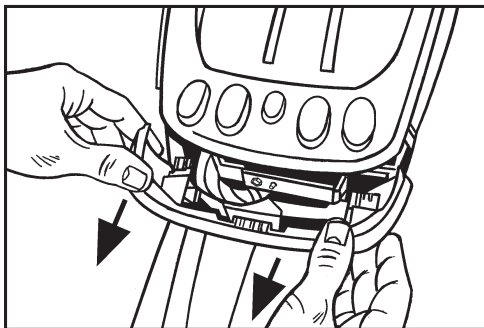

(Figure A)

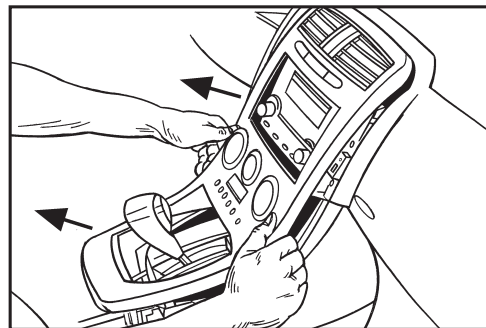

(Figure B)

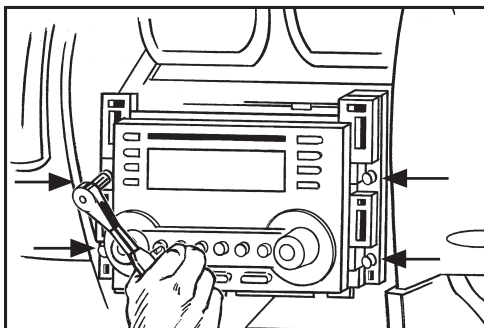

(Figure C)

Continue to Kit Assembly

DASH DISASSEMBLY

Buick Enclave 2008-2012
Chevy Traverse 2009-2012/
GMC Acadia 2007-2012
Saturn Outlook 2007-2010

1. Using the panel removal tool, carefully unclip the radio trim panel, including the A/C vents.
2. Using the panel removal tool, unclip, unplug, and remove the climate control panel.
3. Remove (4) 7mm screws securing the radio, disconnect the wiring, and then remove the radio.

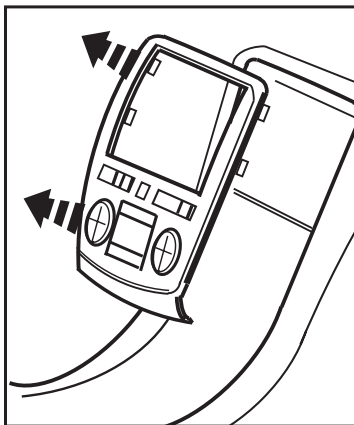

Buick Enclave/Chevy Traverse

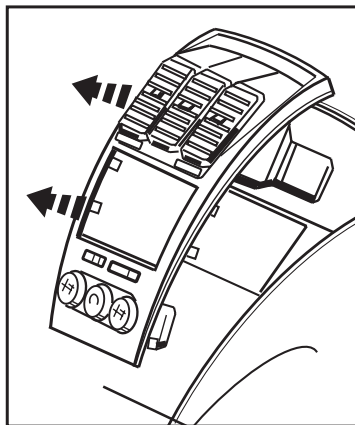

GMC Acadia

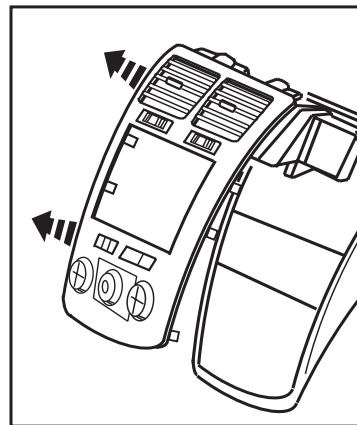

Saturn Outlook

Continue to Kit Assembly

DASH DISASSEMBLY

Hummer H2 2008-2009

1. Using the panel removal tool, gently unclip the radio trim panel, including the A/C vents.
2. Unplug any harnesses connected to the panel, and then remove the panel. (Figure A)
3. Remove (4) 7mm screws securing the climate controls. Unplug and remove the climate controls.
4. Remove (4) 7mm screws securing the radio, disconnect the wiring, and then remove the radio.

Continue to Kit Assembly

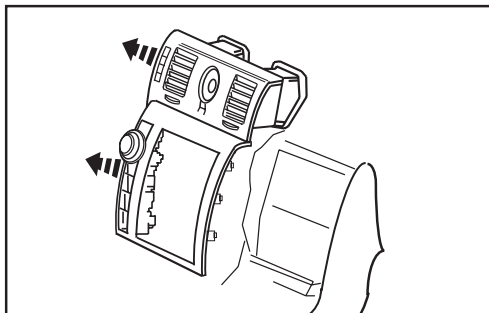

(Figure A)

Chevrolet Captiva Sport 2012-2015/Saturn Vue 2008-2010

1. Using the panel removal tool, carefully unclip and remove the panel on top of the radio trim panel. (Figure A)
2. Remove (2) Phillips screws exposed under the panel previously removed. (Figure B)
3. Using the panel removal tool, gently unclip and remove the radio trim panel, including the A/C vents. (Figure B)
4. Using the panel removal tool, unclip and remove the trim panel surrounding the shifter, including the climate controls. (Figure C)
5. Remove (4) 7mm screws securing the radio, disconnect the wiring, and then remove the radio.

Continue to Kit Assembly

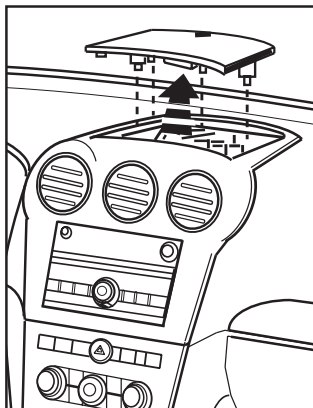

(Figure A)

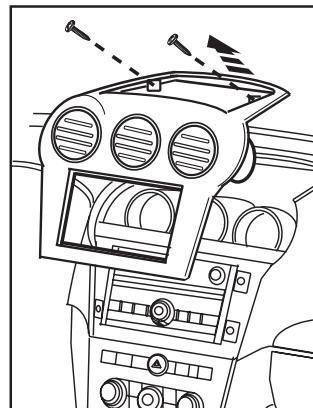

(Figure B)

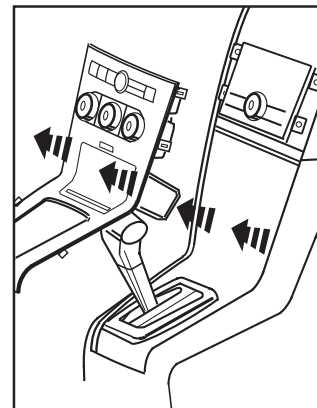

(Figure C)

KIT ASSEMBLY

ISO DIN radio provision with pocket

1. Slide the **radio brackets** into the **radio housing**, aligning the holes in the **radio housing** to the clips on the brackets. (Figure A)
2. Attach the **pocket** to the lower section of the **radio brackets** using the (4) #8 x 3/8" Phillips screws provided with this kit. (Figure B)
For Suzuki XL-7 only: Trim the top corners of the radio housing. (Figure C)

For Aura, Cobalt, G5, HHR, Sky, Vue:

1. Cut and remove the top mounting tabs from the radio housing. (Figure D)
2. Remove the metal DIN sleeve and trim ring from the aftermarket radio.
3. Reconnect the negative battery terminal and test the aftermarket radio for proper operation.
4. Slide the radio into the bracket/pocket assembly, and then secure it using the screws supplied with the radio. (Figure B)
5. Locate the factory wiring harness and antenna connector in the dash and complete all necessary connections to the radio. Metra recommends using the proper mating adapter from Metra or AXXESS.
6. Reconnect the negative battery terminal and test the aftermarket radio for proper operation.
7. Secure the completed assembly into the dash using the factory screws.
8. Reassemble the dash in the reverse order of disassembly to complete the installation.

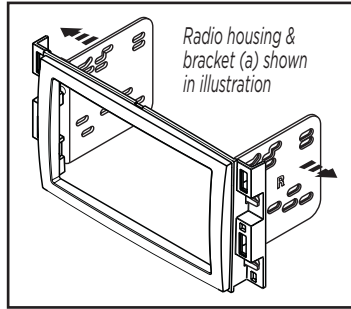

(Figure A)

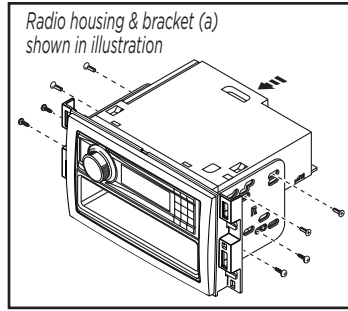

(Figure B)

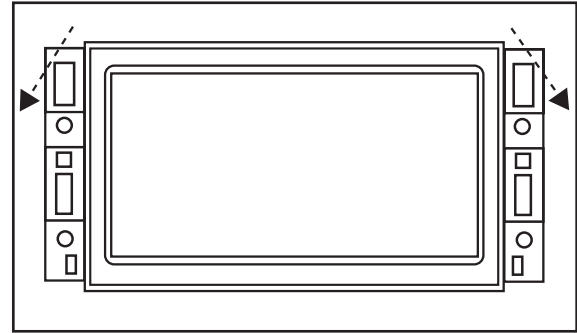

(Figure C)

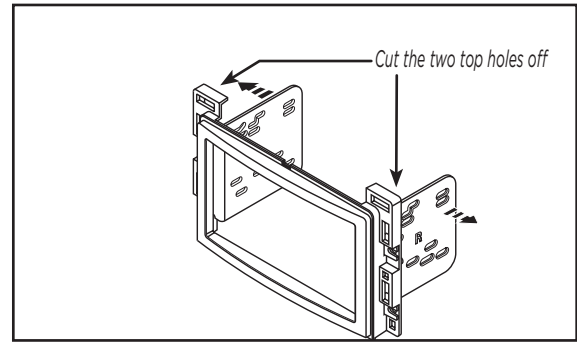

(Figure D)

KIT ASSEMBLY

ISO DDIN radio provision

1. Slide the **radio brackets** into the **radio housing**, aligning the holes in the **radio housing** to the clips on the brackets. (Figure A)
2. Slide the radio into the completed assembly, and then secure using the screws supplied with the radio. (Figure B)

For Suzuki XL-7 only: Trim the top corners of the radio housing. (Figure C)

For Aura, Cobalt, G5, HHR, Sky, Vue: Cut and remove the top mounting tabs from the radio housing. (Figure D)

3. Locate the factory wiring harness and antenna connector in the dash and complete all necessary connections to the radio. Metra recommends using the proper mating adapter from Metra or AXXESS.
4. Reconnect the negative battery terminal and test the aftermarket radio for proper operation.
5. Secure the completed assembly into the dash using the factory screws.
6. Reassemble the dash in the reverse order of disassembly to complete the installation.

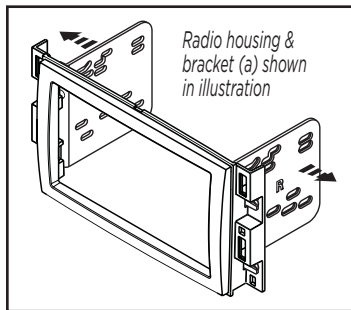

(Figure A)

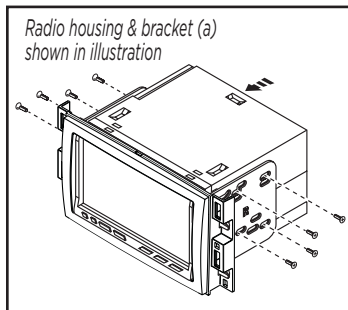

(Figure B)

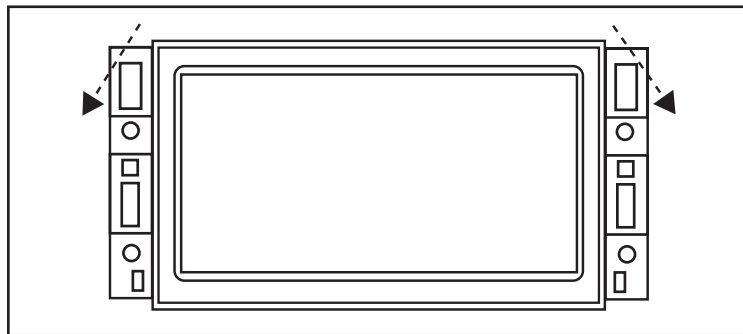

(Figure C)

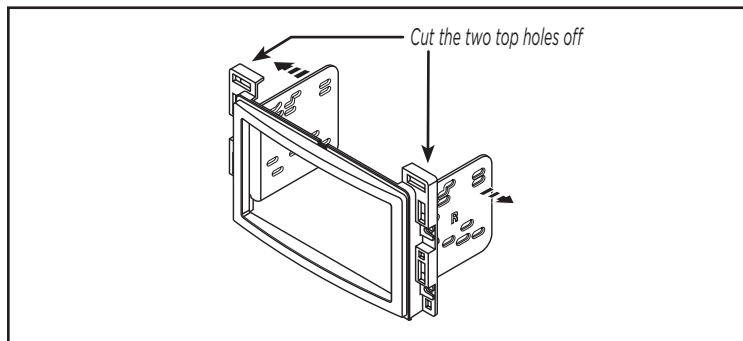

(Figure D)



Having difficulties? We're here to help.



Contact our Tech Support line at:

386-257-1187



Or via email at:

techsupport@metra-autosound.com

Tech Support Hours (Eastern Standard Time)

Monday - Friday: 9:00 AM - 7:00 PM

Saturday: 10:00 AM - 7:00 PM

Sunday: 10:00 AM - 4:00 PM



KNOWLEDGE IS POWER

Enhance your installation and fabrication skills by enrolling in the most recognized and respected mobile electronics school in our industry. Log onto www.installerinstitute.edu or call 386-672-5771 for more information and take steps toward a better tomorrow.



**Metra recommends MECP
certified technicians**



GM Multi-kit 2004 y Mas

CARACTERÍSTICAS DEL KIT

- Provisión de radio ISO DIN con cavidad
- Provisión de radio ISO DDIN

COMPONENTES DEL KIT

- A) Carcasa del radio (a) • B) Soportes de radio • C) Carcasa del radio (b) • D) Cavidad • E) Tornillos Phillips #8 de 3/8" (4)

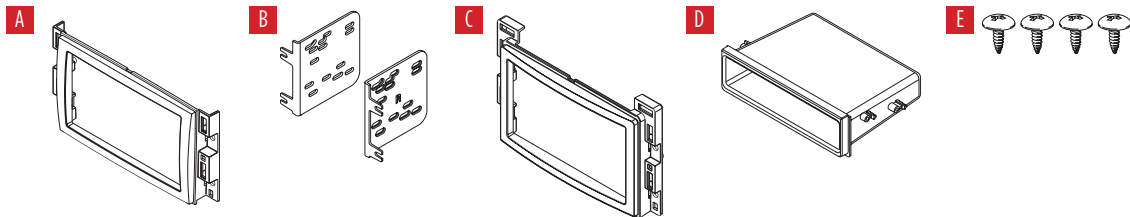

APLICACIONES

Ver interior de la portada

INDICE

Ver interior de la portada

HERRAMIENTAS REQUERIDAS

- Herramienta para quitar paneles
- Destornillador Phillips • llave de tubo 7mm y 10mm
- Destornillador Torx • llave Allen
- Herramienta para cortar

LAS CONEXIONES DE CABLEADO Y ANTENA SE VENDEN POR SEPARADO

ATENCIÓN: Con la llave fuera del encendido, desconecte el terminal negativo de la batería antes de instalar este producto. Asegúrese de que todas las conexiones de la instalación estén seguras antes de encender y apagar el encendido para probar este producto.

NOTA: Consulte las instrucciones incluidas con el radio de mercado secundario.

APLICACIONES

Carcasa de radio y soporte de radio (a)

Buick

Enclave2008-2012
Lucerne2006-2011

Chevrolet

Avalanche2007-2013
Equinox2007-2009
Express2008 y mas
Impala2006-2013
Impala Limited (Fleet)2014
Monte Carlo2006-2007
Silverado**2007-2013
Silverado 2500/35002014
Suburban2007-2014
Tahoe2007-2014
Traverse2009-2012
Captive Sport2012-2015

GMC

Acadia2007-2012
Savana2008 y mas
Sierra**2007-2013
Sierra 2500/35002014
Yukon2007-2014

Hummer

H22008-2009

Pontiac

Torrent2007-2009

Saturn

Outlook2007-2010
Vue2008-2010

Suzuki

XL-72007-2009

**Excluyendo modelos clásicos

Carcasa de radio y soporte de radio (b)

Chevrolet

Cobalt2005-2010
Equinox2005-2006
HHR2006-2011
Malibu2004-2007
Malibu2008-2012

Pontiac

G52007-2009
G62005-2010
Solstice2006-2009
Torrent2006

Saturn

Aura2007-2009
Ion2006-2007
Sky2007-2009
Vue2006-2007

INDICE

Desmontaje tablero

- Buick Enclave 2008-2012	16	- GMC Savana 2008 y mas	13
- Buick Lucerne 2006-2011	12	- GMC Sierra (No incluye los modelos clásicos) 2007-2013	12
- Chevrolet Avalanche 2007-2013	12	- GMC Sierra 2500/3500 2014	12
- Chevrolet Captiva Sport 2012-2015	17	- GMC Yukon 2007-2014	12
- Chevrolet Cobalt 2005-2010	3	- Hummer H2 2008-2009	17
- Chevrolet Equinox 2005-2006	4	- Pontiac G5 2007-2009	3
- Chevrolet Equinox 2007-2009	15	- Pontiac G6 2005-2010	7
- Chevrolet Express 2008 y mas	13	- Pontiac Solstice 2006-2009	8
- Chevrolet HHR 2006-2011	4	- Pontiac Torrent 2006	4
- Chevrolet Impala 2006-2013	12	- Pontiac Torrent 2007-2009	15
- Chevrolet Impala Limited (Fleet) 2014	12	- Saturn Aura 2007-2009	9
- Chevrolet Malibu 2004-2007	5-6	- Saturn Ion 2006-2007	9
- Chevrolet Malibu 2008-2012	6-7	- Saturn Outlook 2007-2010	16
- Chevrolet Monte Carlo 2006-2007	12	- Saturn Sky 2007-2009	10
- Chevrolet Silverado Pickup (excluding classic models) 2007-2013	12	- Saturn Vue 2006-2007	11
- Chevrolet Silverado 2500/3500 2014	12	- Saturn Vue 2008-2010	17
- Chevrolet Suburban 2007-2014	12	- Suzuki XL-7 2007-2009	14
- Chevrolet Tahoe 2007-2014	12		
- Chevrolet Traverse 2009-2012	16		
- GMC Acadia 2007-2012	16		

Ensamble del kit

- Provisión de radio ISO DIN con cavidad	18
- Provisión de radio ISO DDIN	19

DESMONTAJE TABLERO

Chevrolet Cobalt 2005-2010
Pontiac G5 2007-2009

1. Desenganche y quite el panel de la moldura que está sobre la guantera. (Figura A)
2. Desenganche el borde arriba del panel debajo de la columna de dirección y deje que cuelgue. No es necesario quitarlo completamente. (Figura B)
3. Desenganche y quite el pequeño panel de la moldura a la derecha del interruptor de arranque. (Figura C)
4. Desenganche y quite todo el panel que rodea la radio y los controles de clima. (Figura D)
5. Quite los (4) tornillos de 9/32 que sujetan la radio. Desconecte y quite la radio. (Figura E)

Continúe con el *Ensamble del Kit*

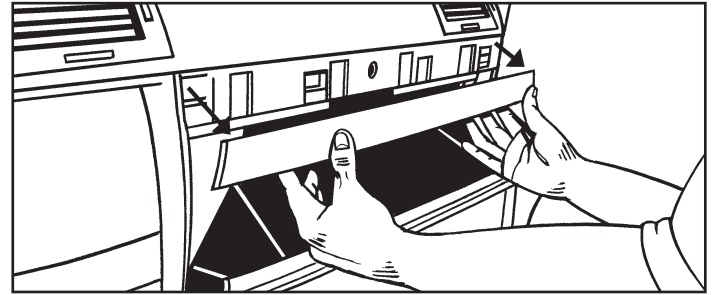

(Figura A)

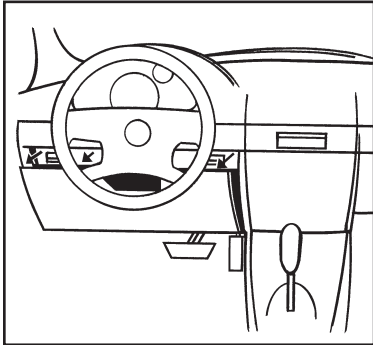

(Figura B)

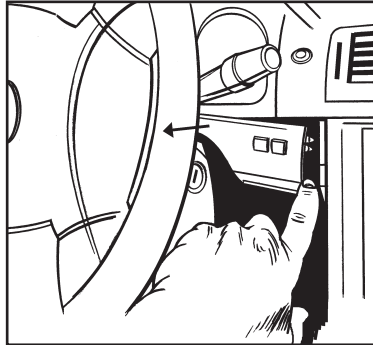

(Figura C)



(Figura D)

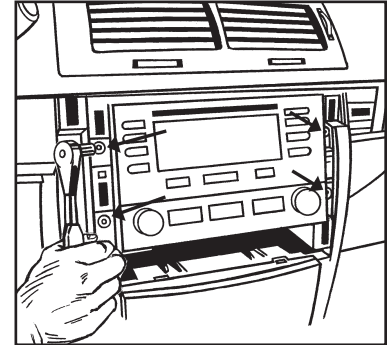

(Figura E)

DESMONTAJE TABLERO

Chevrolet Equinox 2005-2006 Pontiac Torrent 2006

1. Suelte a presión el panel debajo del interruptor de la ventanilla eléctrica y retire.

Nota: Esto le permite desconectar el interruptor de la ventana más fácilmente. (Figura A)

2. Suelte a presión y quite todo el panel que rodea la radio y la palanca de velocidades. (Figura B)
3. Quite los (4) tornillos de 9/32 que sujetan la radio. Desconecte y quite la radio. (Figura C)

Continúe con el Ensamble del Kit

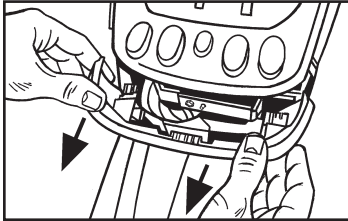

(Figura A)

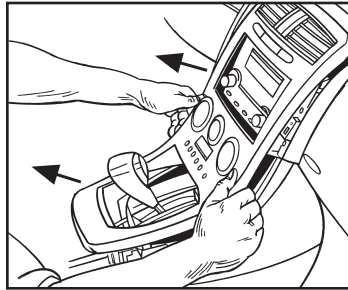

(Figura B)

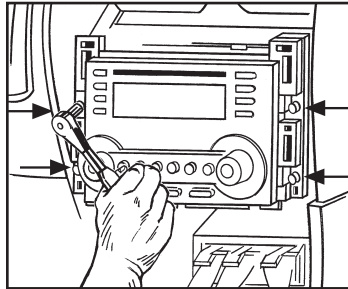

(Figura C)

Chevrolet HHR 2006-2011

1. Desenganche y quite todo el panel que rodea la radio y los controles de clima, incluidas las rejillas del aire acondicionado. (Figura A)
2. Retire (8) tornillos de 9/32 "que aseguran la radio y el control de A / C para quitar la radio. (Figura B)

Continúe con el Ensamble del Kit

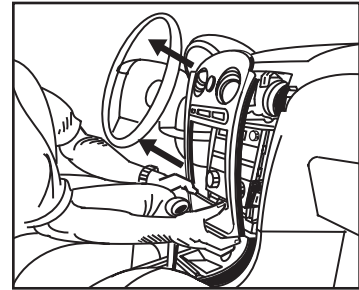

(Figura A)

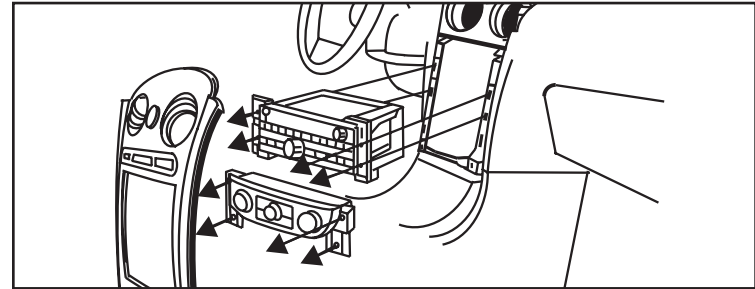

(Figura B)

DESMONTAJE TABLERO

Chevrolet Malibu 2004-2007

1. Desenganche y quite las piezas de la moldura de grano de madera/pintada de ambos lados del volante. (Figura A)
2. Desenganche y quite el panel lateral del tablero del lado del conductor con la puerta abierta y quite (2) tornillos de 7mm (Figura B)
3. Quite los (2) tornillos de 7 mm del borde inferior del panel debajo del volante, desenganche el panel y deje que cuelgue. No es necesario quitar el panel completamente. (Figura C)
4. Desenganche y quite la pieza de la moldura de grano de madera/pintada sobre la guantera. (Figura D)

Continúa en la página siguiente

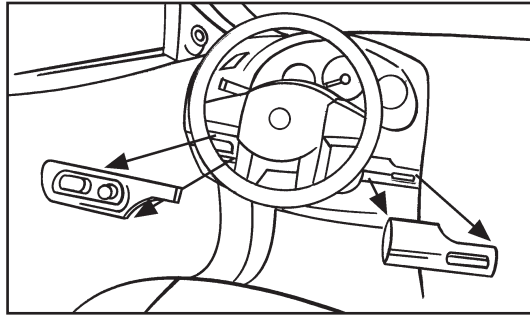

(Figura A)

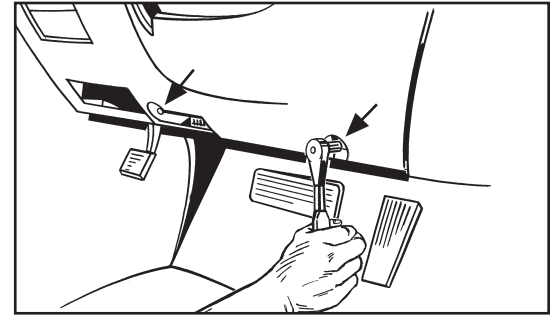

(Figura C)

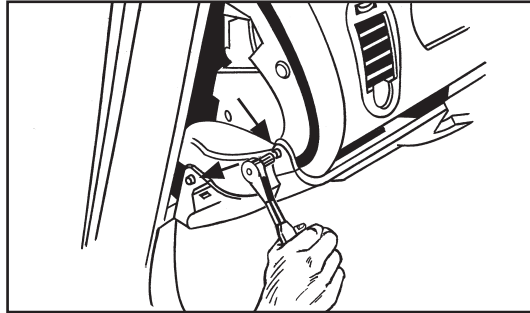

(Figura B)

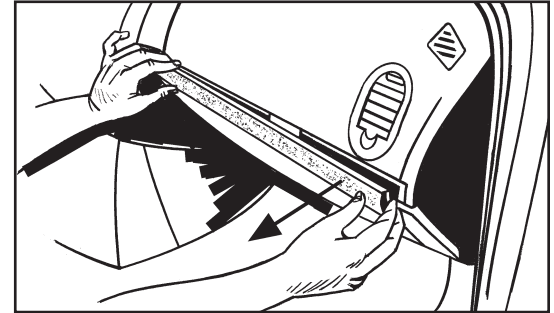

(Figura D)

DESMONTAJE TABLERO

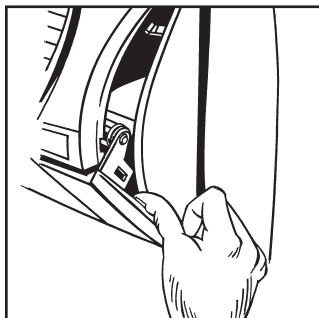

(Figura E)

Chevrolet Malibu 2004-2007 (Cont)

5. Desenganche y quite el panel lateral del tablero del lado del pasajero con la puerta abierta y quite (2) tornillos de 7 mm detrás del panel. (Figura E)
6. Quite los (2) tornillos de 7 mm debajo de la guantera, abra la guantera y apriete ambos lados para abrirla más y retire los (4) tornillos de 7 mm restantes. Desenganche la cubierta de las rejillas negra debajo de la guantera y luego desenganche y quite todo el ensamblaje de la guantera. (Figura F)
7. Desenganche y quite todo el panel que rodea la radio y los controles de clima. (Figura G)
8. Quite los (4) tornillos de 7 mm que fijan la radio y los (2) tornillos de 7 mm que fijan el control del clima. Desconecte y quite la radio. (Figura H)

Continúe con el Ensamble del Kit

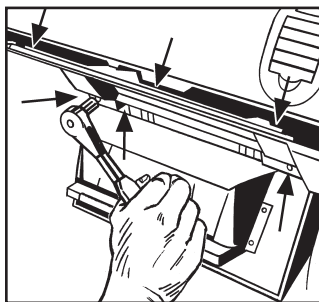

(Figura F)

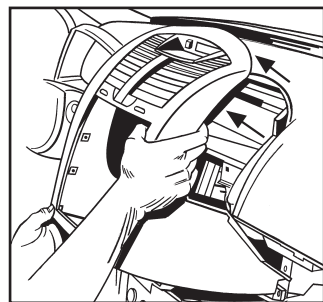

(Figura G)

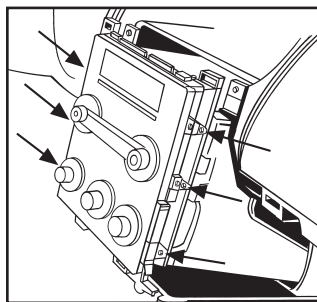

(Figura H)

Chevrolet Malibu 2008-2012

1. Suelte a presión y quite la moldura de la palanca de velocidades. (Figura A)
- Nota:** Comience por la palanca de velocidades y asegúrese de jalar hacia abajo antes que hacia atrás porque este panel se desliza hacia arriba por debajo de los paneles de la radio/clima.
2. Quite los (2) tornillos 8mm de la parte de abajo del panel de la radio/clima.
 3. Suelte a presión y quite el panel del clima/radio y el panel de la moldura de la rejilla superior de forma conjunta. Pueden separarse después de retirarse. (Siguiendo página)
 4. Quite los (6) tornillos 8mm de los controles de la radio y el clima.

Continúe con el Ensamble del Kit

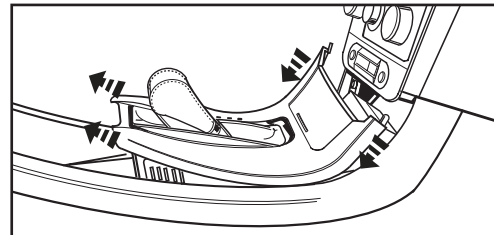

(Figura A)

DESMONTAJE TABLERO

Chevrolet Malibu 2008-2012 (Cont)

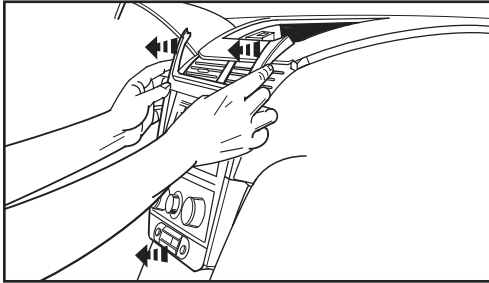

(Figura B)

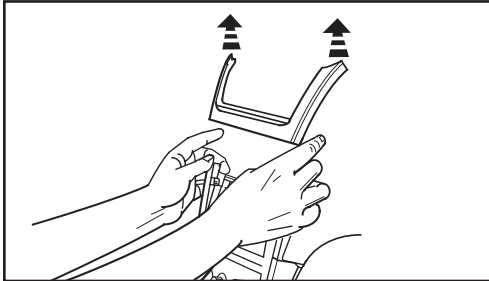

(Figura C)

Pontiac G6 2005-2010

1. Abra la guantera y quite los (6) tornillos del borde exterior, y luego desenganche y retire la guantera. (Figura A)
2. Quite los (4) tornillos del panel debajo de la columna de dirección. Desenganche y quite el panel. (Figura B)
3. Desenganche y retire el panel central que rodea la radio y los controles del aire acondicionado. (Figura C)
4. Retire (4) tornillos que aseguran la radio. Desenchufe y retire la radio. (Figura D)

Continúe con el Ensamble del Kit

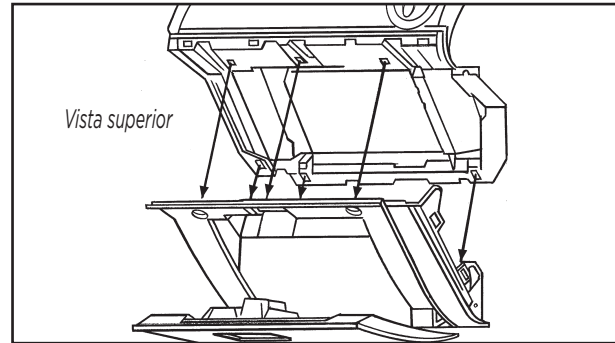

(Figura A)

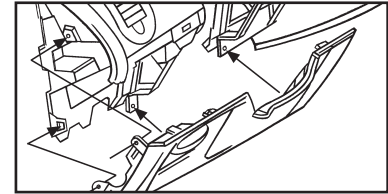

(Figura B)

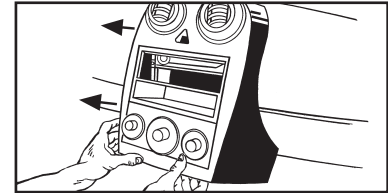

(Figura C)

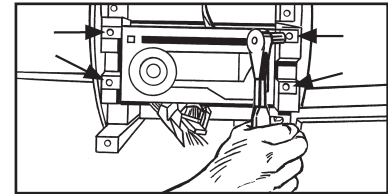

(Figura D)

DESMONTAJE TABLERO

Pontiac Solstice 2006-2009

1. (A) Transmisión manual:

Levante el borde inferior de la placa de moldura del conjunto del panel de instrumentos lo suficiente para alcanzar por debajo y liberar las pestañas que sostienen el anillo de la moldura de la cubierta de la palanca de velocidades. (Figura A)

Levante la cubierta de la palanca de velocidades y afloje el tornillo de fijación para liberar la palanca de velocidades. (Figura B)

1. (B) Transmisión automática:

Desenganche y quite el anillo de la moldura de la palanca de velocidades. (Figura C)

2. Desenganche y quite el panel de la moldura de la manija auxiliar del pasajero. (Figura D)
3. Quite los (2) tornillos que fijan la manija auxiliar del pasajero y quite la manija. (Figura D)
4. Desenganche y quite el panel de la moldura de la consola central.
5. Retire (4) tornillos que aseguran la radio. Desenchufe y retire la radio.

Continúe con el Ensamble del Kit

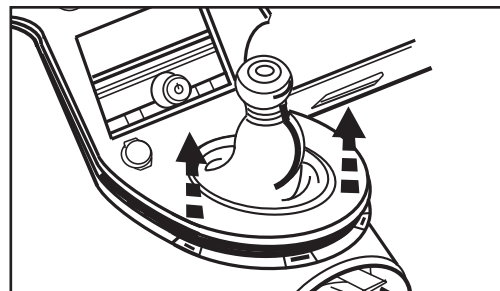

(Figura A)

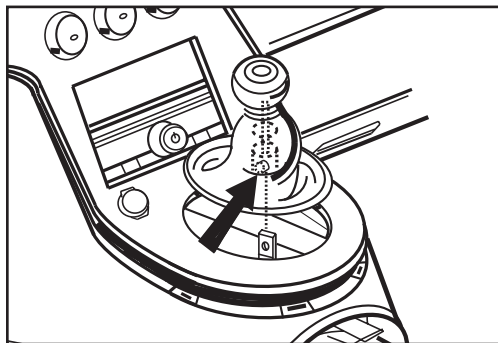

(Figura B)

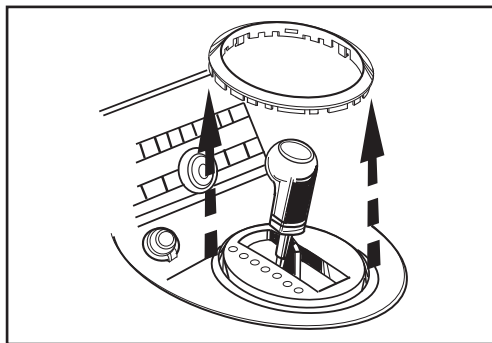

(Figura C)

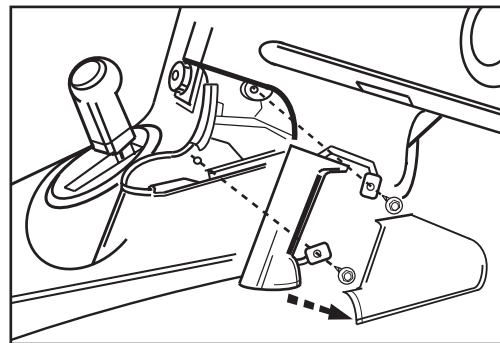

(Figura D)

DESMONTAJE TABLERO

Saturn Aura 2007-2009

1. Desenganche y quite el anillo de la moldura de la palanca de velocidades. (Figura A)
2. Desenganche y quite el panel de la moldura de la consola central, luego quite los (2) tornillos del borde inferior del panel de la moldura del tablero. (Figura B)
3. Desenganche y quite el anillo de la moldura del interruptor de la llave, luego desenganche y quite el panel de la moldura del tablero. (Figura C)
4. Quite los (2) tornillos que fijan los controles del clima.
5. Retire (4) tornillos que aseguran la radio. Desenchufe y retire la radio.

Continúe con el Ensamble del Kit

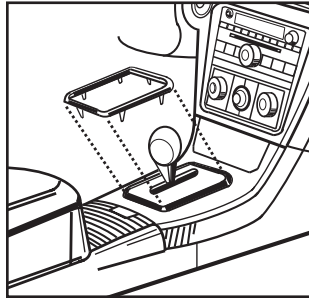

(Figura A)

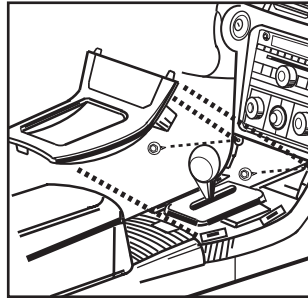

(Figura B)

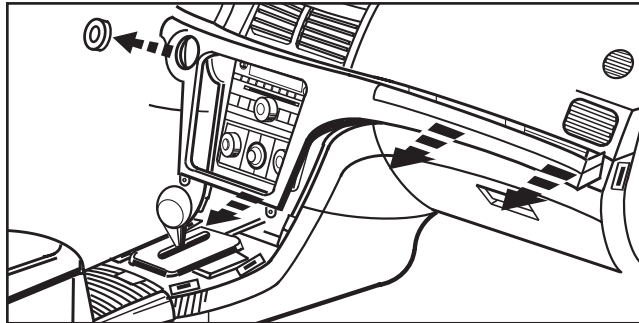

(Figura C)

Saturn Ion 2006-2007

1. Desenganche el panel de acabado de la radio. (Figura A)
2. Desenchufe los conectores del panel embellecedor y retire el panel. (Figura B)
3. Retire (4) tornillos que aseguran la radio. Desenchufe y retire la radio.

Continúe con el Ensamble del Kit

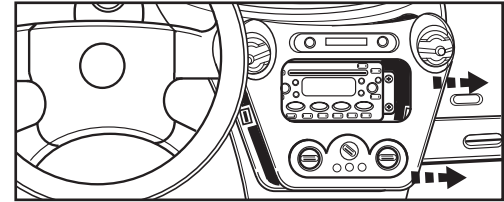

(Figura A)

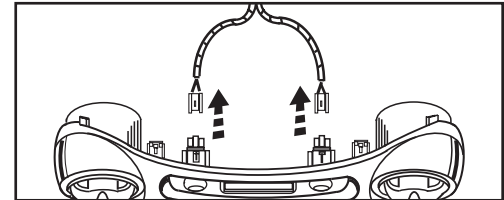

(Figura B)

DESMONTAJE TABLERO

Saturn Sky 2007-2009

1. Desenganche y quite el panel lateral del tablero del lado del conductor con la puerta abierta y quite (2) tornillos de 7mm. (Figura A)
2. Quite los (2) tornillos de 7 mm del borde inferior del panel debajo del volante, desenganche el panel y retírelo.
3. Desenganche y quite el panel lateral del tablero del lado del pasajero con la puerta abierta y quite (2) tornillos de 7 mm detrás del panel. (Figura B)
4. Abra la guantera y desconecte amortiguador de la guantera del ensamble de la guantera. Apriete ambos lados para abrirla más. (Figura C)
5. Quite las (2) cubiertas de los pernos de la parte superior del marco de la guantera. (Figura C)
6. Quite los (5) pernos del marco de la guantera y quite el marco. (Figura C)
7. Suelte a presión el panel de la moldura del control de clima. (Figura D)
8. Quite (1) tornillo de la esquina inferior izquierda del panel de la moldura de la radio y desconecte los conectores para quitar el panel. (Figura D)
9. Retire (4) tornillos que aseguran la radio. Desenchufe y retire la radio.

Continúe con el Ensamble del Kit

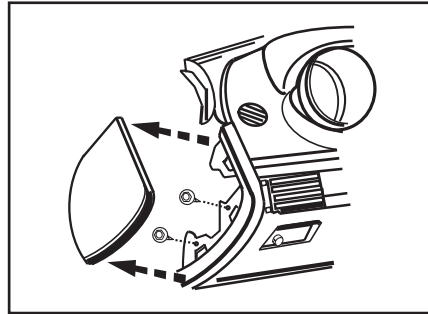

(Figura A)

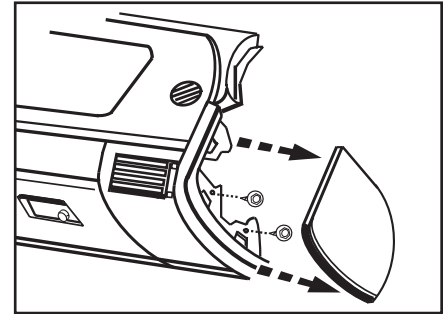

(Figura B)

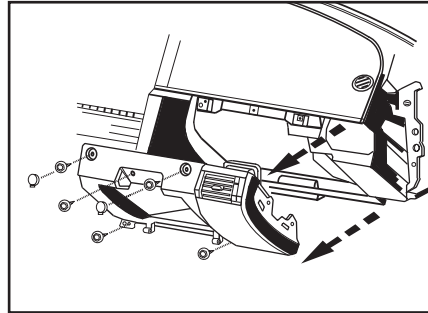

(Figura C)

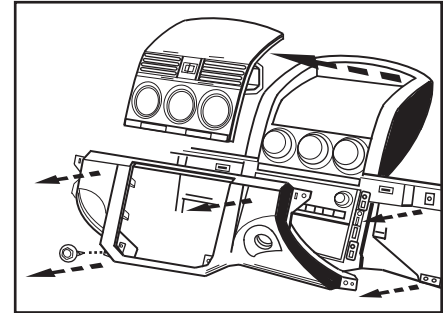

(Figura D)

DESMONTAJE TABLERO

Saturn Vue 2006-2007

1. Sostenga el borde frontal del panel de la moldura de la palanca de velocidades y jale hacia afuera y hacia arriba.
2. Apriete las pestañas de bloqueo localizadas en el borde frontal del panel de la moldura de la palanca de velocidades para liberar el borde frontal del panel de la consola central.
3. Jale hacia arriba en el panel para liberar los broches restantes y quite el panel de la moldura.
4. Quite los (4) tornillos que sujetan la cavidad de almacenamiento y quitela.
5. Desenganche y quite el panel de la moldura del tablero central.
6. Retire (4) tornillos que aseguran la radio. Desenchufe y retire la radio.

Continúe con el Ensamble del Kit

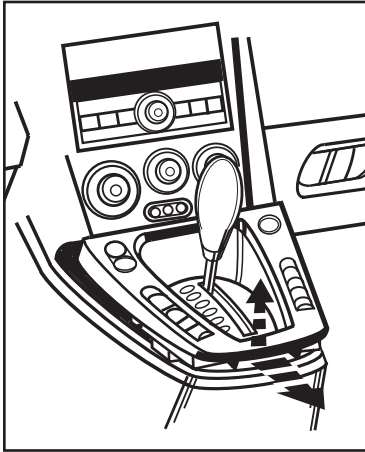

(Figura A)

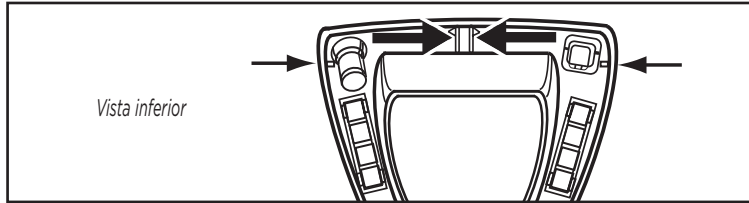

(Figura B)

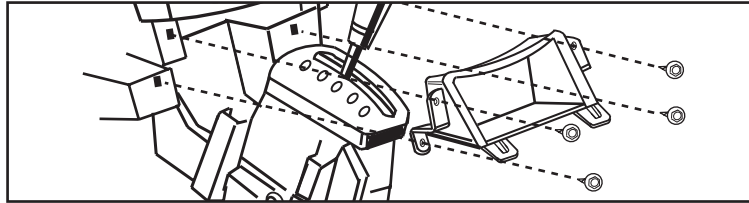

(Figura C)

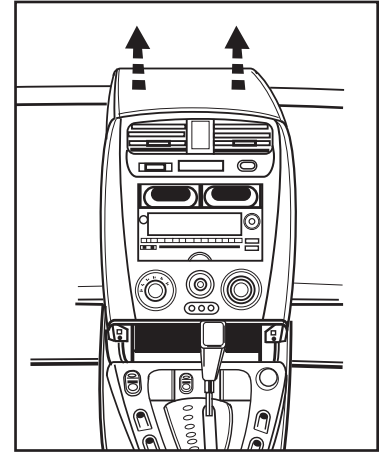

(Figura D)

DESMONTAJE TABLERO

**Buick Lucerne 2006-2011 /
Chevrolet Impala 2006-2013, Impala Limited (Fleet) 2014,
Monte Carlo 2006-2007**

1. Desenganche y retire el panel de terminación que rodea el control del radio y del aire acondicionado. (Figura A)
2. Retire (6) tornillos de 7mm in para extraer el control del radio y del aire acondicionado del subtablero. (Figura B)

Continúe con el Ensamble del Kit

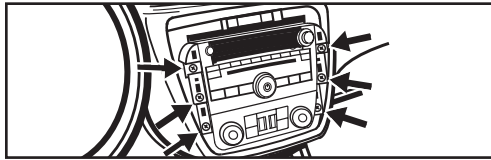

(Figura A)

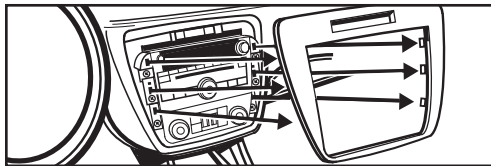

(Figura B)

**Chevrolet Avalanche 2007-2013,
Silverado (No incluye los modelos clásicos) 2007-2013,
Tahoe/Suburban 2007-2014, Silverado 2500/3500 2014 /
GMC Yukon 2007-2014,
Sierra (No incluye los modelos clásicos) 2007-2013,
Sierra 2500/3500 2014**

1. Desenganche y retire el panel de terminación del radio. (Figura A)
2. Retire (2) tornillos de 7mm que sujetan el panel de interruptores debajo de los controles de clima. Desenchufe y retire el panel de interruptores.(Figura B)
3. Retire (2) tornillos de 7mm que sujetan los controles de clima. Desenchufe y retire los controles de clima. (Figura B)
4. Retire (4) tornillos de 7mm in que sujetan el radio. Desenchufe y retire el radio. (Figura C)

Continúe con el Ensamble del Kit

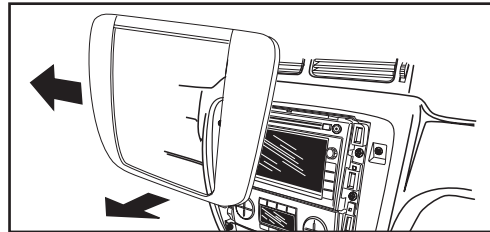

(Figura A)

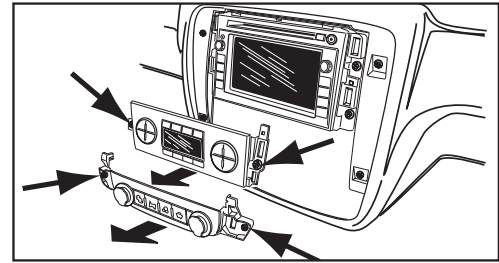

(Figura B)

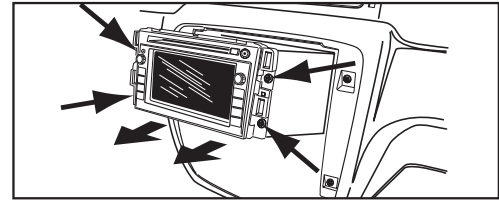

(Figura C)

DESMONTAJE TABLERO

Chevy Express GMC Savana 2008 y mas

1. Retire (2) pernos de 10mm de la parte de abajo del amortiguador para las rodillas que se encuentra debajo de la columna de la dirección y retire el panel. (Figura A)
2. Retire (2) pernos de 10mm del panel que se encuentra debajo del airbag del tablero del pasajero y retire el panel. (Figura B)
3. Quite a presión y retire el panel del radio y del grupo de instrumentos. (Figura C)

Nota: Es posible que no sea necesario retirar completamente el panel del radio y del grupo de instrumentos para tener acceso al radio.

4. Retire (4) pernos de 7mm in para retirar el radio. (Figura D)

Continúe con el Ensamble del Kit

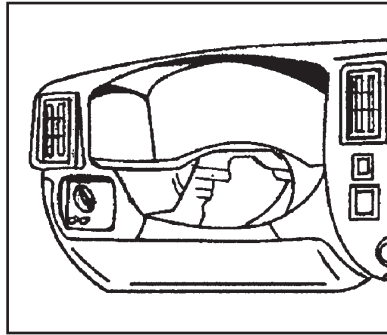

(Figura A)

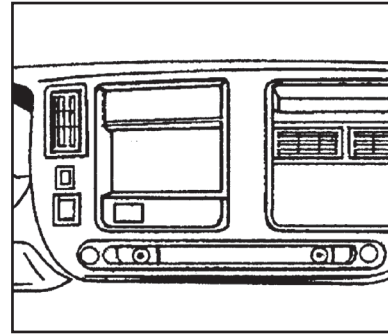

(Figura C)

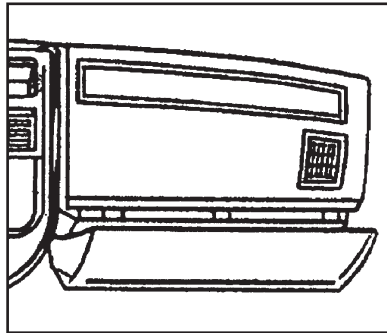

(Figura B)

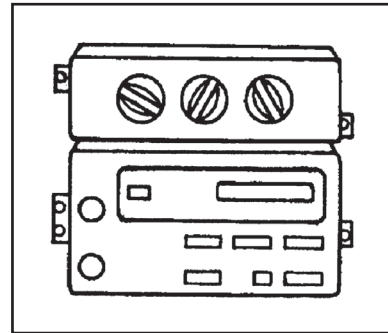

(Figura D)

DESMONTAJE TABLERO

Suzuki XL-7 2007-2009

1. Presione los lados de la cubierta de protección de la palanca de velocidades para liberarla del panel de terminación de la palanca de velocidades. (Figura A)
2. Levante la cubierta de protección para poder acceder al tornillo Allen, que sujeta la perilla de la palanca de velocidades a la palanca de velocidades. Afloje el tornillo Allen y retire la perilla de la palanca de velocidades. (Figura B)
3. Retire (1) tornillo Torx del panel de terminación de la palanca de velocidades (Figura C), y luego use una herramienta para retirar paneles para quitar a presión el panel de terminación de la palanca de velocidades. Desenchufe y retire el panel. (Figura D)
4. Con una herramienta para retirar paneles, quite a presión el panel de terminación del radio. Desenchufe y retire el panel. (Figura E)
5. Retire (4) tornillos de 7mm in que sujetan el radio. Desenchufe y retire el radio.

Continúe con el Ensamble del Kit

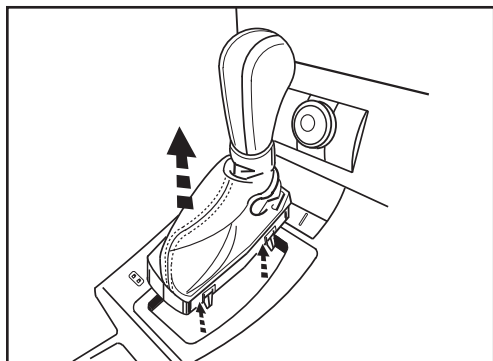

(Figura A)

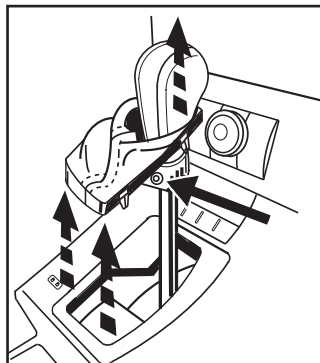

(Figura B)

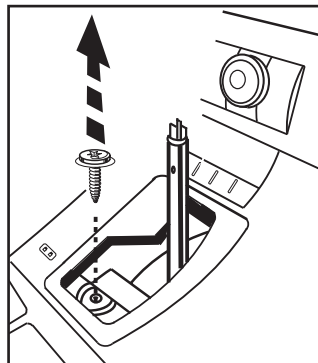

(Figura C)

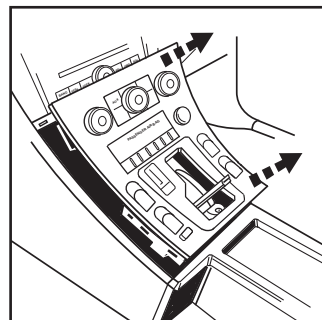

(Figura D)

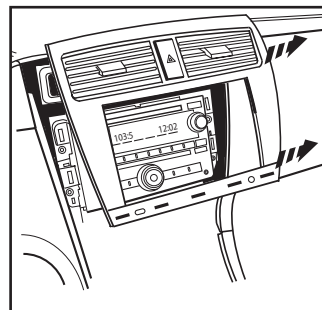

(Figura E)

DESMONTAJE TABLERO

Chevy Equinox/Pontiac Torrent 2007-2009

1. Quite a presión el panel que se encuentra debajo del interruptor del alzacristales y retírelo. (Figura A)
Nota: Esto le permite desenchufar el interruptor de las ventanas con mayor facilidad.
2. Quite a presión y retire el panel completo que rodea el radio y la palanca de velocidades. (Figura B, página siguiente)
3. Retire (4) tornillos de 7mm in que sujetan el radio. Desenchufe y retire el radio. (Figura C)

Continúe con el Ensamble del Kit

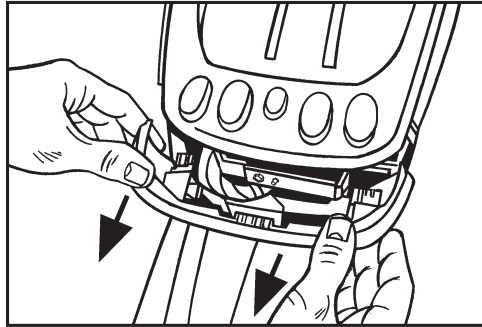

(Figura A)

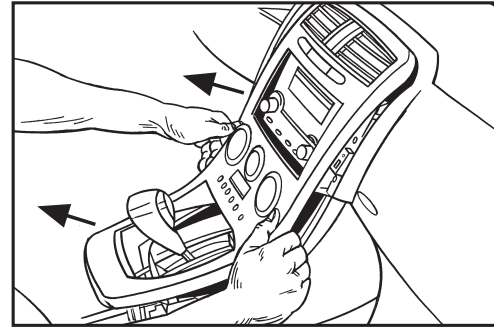

(Figura B)

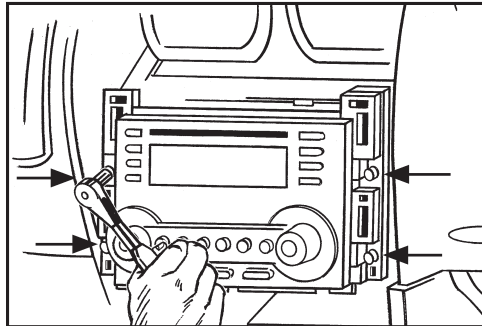

(Figura C)

DESMONTAJE TABLERO

Buick Enclave 2008-2012
Chevy Traverse 2009-2012/
GMC Acadia 2007-2012
Saturn Outlook 2007-2010

1. Desenganche el panel de terminación del radio, incluidos los controles de clima.
2. Desenchufe los controles de clima y retire el panel.
3. Retire (4) tornillos de 7mm in que sujetan el radio. Desenchufe y retire el radio.

Continúe con el Ensamble del Kit

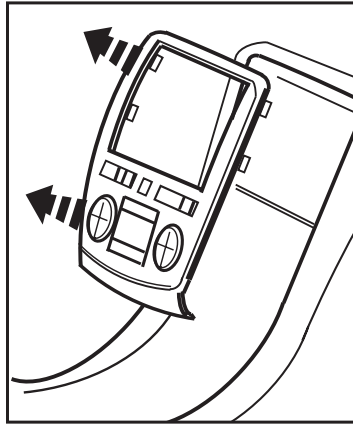

Buick Enclave/Chevy Traverse

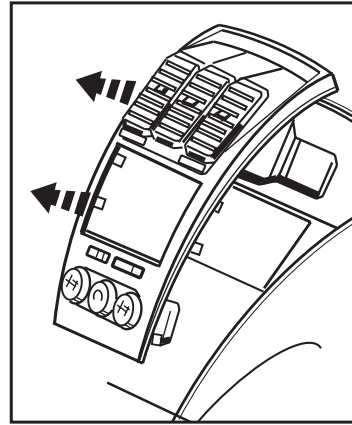

GMC Acadia

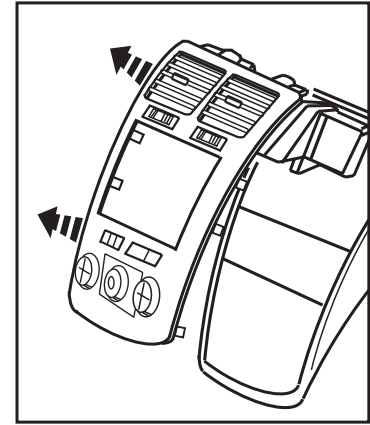

Saturn Outlook

DESMONTAJE TABLERO

Hummer H2 2008-2009

1. Desenganche el panel de terminación del radio, incluidas las rejillas de ventilación del aire acondicionado.
2. Desenchufe cualquier arnés que esté conectado al panel, y retire el panel. (Figura A)
3. Retire (4) tornillos de 7mm in que sujetan los controles de clima.
4. Desenchufe y retire los controles de clima.
5. Retire (4) tornillos de 7mm in que sujetan el radio. Desenchufe y retire el radio.

Continúe con el Ensamble del Kit

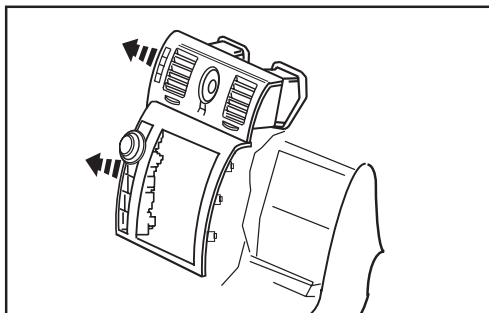

(Figura A)

Chevrolet Captiva Sport 2012-2015/Saturn Vue 2008-2010

1. Desenganche y retire el panel de terminación que está en la parte superior del panel de terminación del radio. (Figura A)
2. Retire (2) tornillos Phillips expuestos que se encuentran debajo del panel que se retiró. (Figura B)
3. Desenganche y retire el panel de terminación del radio, incluidas las rejillas de ventilación del aire acondicionado. (Figura B)
4. Desenganche y retire el panel de terminación que rodea la palanca de velocidades, incluidos los controles de clima. (Figura C)
5. Retire (4) tornillos de 7mm in que sujetan el radio. Desenchufe y retire el radio.

Continúe con el Ensamble del Kit

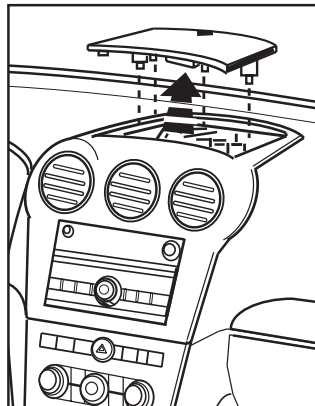

(Figura A)

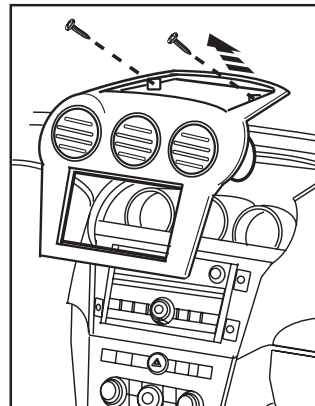

(Figura B)

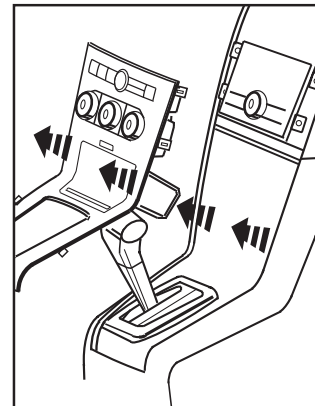

(Figura C)

ENSAMBLE DEL KIT

Provisión de radio ISO DIN con cavidad

1. Deslice los **soportes de radio** en la **carcasa de la radio**, la alineación de los agujeros en la **carcasa de radio** a los clips en los soportes. (Figura A)
2. Sujete la **cavidad** a la sección inferior de los **soportes del radio** usando los (4) tornillos Phillips #8 x 3/8". (Figura B)
3. Quite la manga de metal DIN y el anillo de moldura del radio de mercado secundario.
4. Deslice el radio dentro del conjunto del soporte/la cavidad y luego sujételo con los tornillos suministrados con el radio. (Figura B)

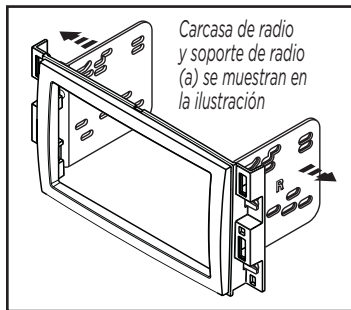

(Figura A)

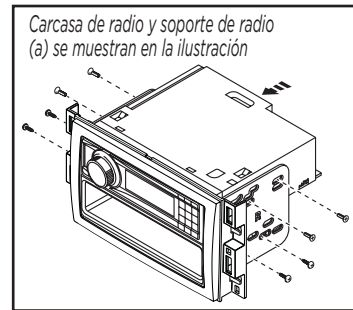

(Figura B)

5. Localice el arnés de cableado de fábrica y el conector de la antena en el tablero, y haga todas las conexiones necesarias al radio. Metra recomienda que use adaptadores adecuados de acoplamiento de Metra y/o de AXCESS. Pruebe el radio para verificar que funcione correctamente.
6. Atornille la ensamble terminado en el tablero y vuelva a armarlo al revés de como lo desarmó.
7. **Suzuki XL-7 solamente:** Recorte las esquinas superiores de la **carcasa de la radio**. (Figura C)

Aura, Cobalt, G5, HHR, Sky, Vue: Corte y retire las pestañas de montaje superiores de la **carcasa del radio**. (Figura D)

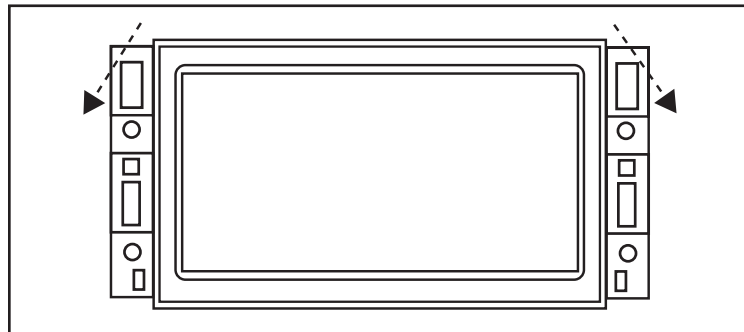

(Figura C)

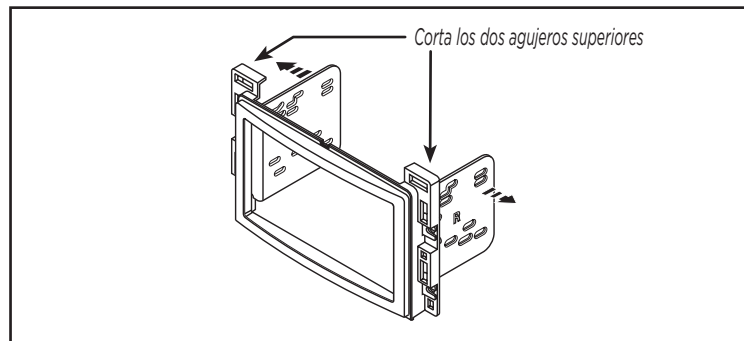

(Figura D)

ENSAMBLE DEL KIT

Provisión de radio ISO DDIN

1. Deslice los **soportes de radio** en la **carcasa de la radio**, la alineación de los agujeros en la **carcasa de radio** a los clips en los soportes. (Figura A)
2. Deslice el radio dentro del conjunto del soporte/la cavidad y luego sujételo con los tornillos suministrados con el radio. (Figura B)
3. Localice el arnés de cableado de fábrica y el conector de la antena en el tablero, y haga todas las conexiones necesarias al radio. Metra recomienda que use

adaptadores adecuados de acoplamiento de Metra y/o de AXCESS. Pruebe el radio para verificar que funcione correctamente.

4. Atornille la ensamble terminado en el tablero y vuelva a armarlo al revés de como lo desarmó.
5. **Suzuki XL-7 solamente:** Recorte las esquinas superiores de la **carcasa de la radio**. (Figura C)

Aura, Cobalt, G5, HHR, Sky, Vue: Corte y retire las pestañas de montaje superiores de la **carcasa del radio**. (Figura D)

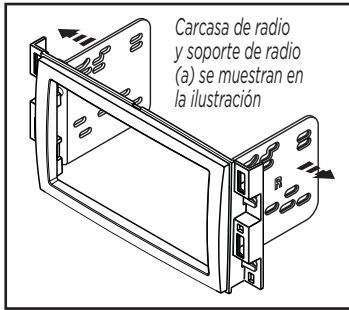

(Figura A)

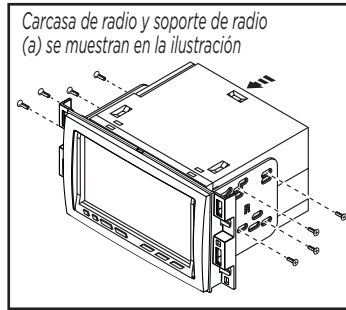

(Figura B)

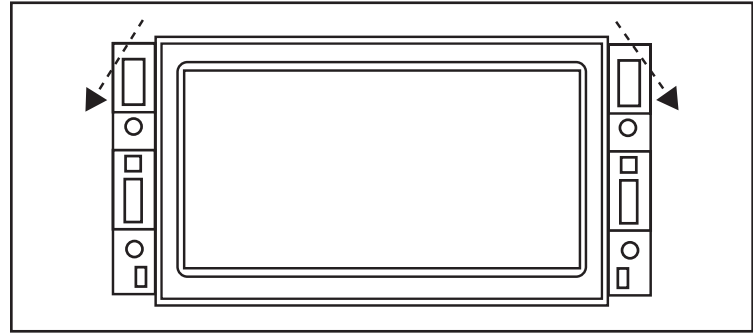

(Figura C)

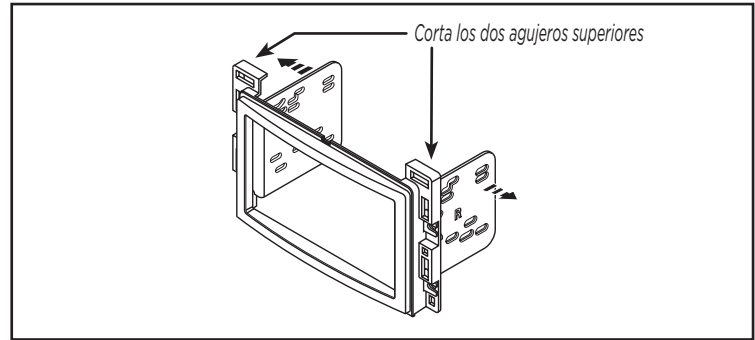

(Figura D)



INST-GMK01

INSTRUCCIONES DE INSTALACIÓN

¿Tienes dificultades? Estamos aquí para ayudar.



Póngase en contacto con nuestra línea de soporte técnico en:
386-257-1187



O por correo electrónico a:
techsupport@metra-autosound.com

Horas de soporte técnico (hora estándar del este)

Monday - Friday: 9:00 AM - 7:00 PM

Saturday: 10:00 AM - 7:00 PM

Sunday: 10:00 AM - 4:00 PM



KNOWLEDGE IS POWER

Enhance your installation and fabrication skills by enrolling in the most recognized and respected mobile electronics school in our industry. Log onto www.installerinstitute.edu or call 386-672-5771 for more information and take steps toward a better tomorrow.



**Metra recomienda MECP
técnicos certificados**