



**BELMONT, CALIFORNIA
STANDARD SPECIFICATIONS
AND
STANDARD DRAWINGS**

APRIL 2021

STANDARD SPECIFICATION

**MID-PENINSULA WATER DISTRICT
STANDARD SPECIFICATIONS AND DRAWINGS
TABLE OF CONTENTS**

SECTION	01 33 00 - SUBMITTALS	1
PART 1	GENERAL.....	1
1.01	SCOPE OF WORK.....	1
1.02	SUBMITTAL PROCEDURE	1
1.03	SHOP DRAWINGS.....	2
1.04	SAMPLES AND TESTS	2
1.05	CERTIFICATES.....	3
1.06	PROGRESS SCHEDULES	3
1.07	TRAFFIC CONTROL PLAN.....	3
1.08	RECORD DRAWINGS	3
1.09	SUBMITTAL SCHEDULE	4
PART 2	MATERIALS - NONE.....	5
PART 3	EXECUTION - NONE.....	5
SECTION	01 45 00 - QUALITY CONTROL	7
PART 1	GENERAL.....	7
1.01	SCOPE OF WORK.....	7
1.02	GENERAL QUALITY	7
1.03	QUALITY IN ABSENCE OF DETAILED SPECIFICATIONS	7
1.04	DEFECTIVE MATERIALS	7
1.05	GUARANTEE.....	7
PART 2	MATERIALS - NONE.....	8
PART 3	EXECUTION - NONE.....	8
SECTION	01 70 00 - PROJECT CLOSEOUT	9
PART 1	GENERAL.....	9
1.01	SCOPE OF WORK.....	9
1.02	SUBMITTALS	9
1.03	INSPECTION	9
PART 2	MATERIALS - NONE.....	10
PART 3	EXECUTION	10
3.01	CLEANING	10

**MID-PENINSULA WATER DISTRICT
STANDARD SPECIFICATIONS AND DRAWINGS
TABLE OF CONTENTS**

SECTION	03 30 00 - CAST-IN-PLACE CONCRETE	11
PART 1	GENERAL.....	11
1.01	SCOPE OF WORK.....	11
1.02	SUBMITTALS	11
PART 2	MATERIALS.....	12
2.01	FORMWORK.....	12
2.02	PORTLAND CEMENT	12
2.03	ADDITIVES.....	12
2.04	CONCRETE AGGREGATES.....	12
2.05	WATER	12
2.06	CONCRETE.....	13
2.07	CONTROLLED DENSITY FILL (2-SACK SLURRY)	13
2.08	BARS.....	13
2.09	WIRE.....	13
2.10	THRUST BLOCKS.....	13
PART 3	EXECUTION	14
3.01	FORMWORK.....	14
3.02	INSTALLATION OF REINFORCING STEEL	14
3.03	PLACEMENT OF CONCRETE	15
3.04	CURING	15
3.05	CONSTRUCTION JOINTS.....	15
3.06	EXPANSION JOINTS.....	15
3.07	EMBEDDED ITEMS	15
3.08	REPAIR OF SURFACE DEFECTS	15
3.09	CONCRETE COMPRESSIVE STRENGTH TESTS.....	16
3.10	CONCRETE SLUMP TESTS.....	16
SECTION	13 47 13 – CATHODIC PROTECTION OF DUCTILE IRON WATER MAIN	17
PART 1	GENERAL.....	17
1.01	SCOPE OF WORK.....	17
1.02	REQUIREMENTS.....	17
1.03	REFERENCED SPECIFICATIONS, CODES AND STANDARDS.....	17
1.04	QUALITY ASSURANCE	20
1.05	SUBMITTALS	20
1.06	INTERFERENCE AND EXACT LOCATIONS.....	20
PART 2	MATERIALS.....	21
2.01	GENERAL.....	21

**MID-PENINSULA WATER DISTRICT
STANDARD SPECIFICATIONS AND DRAWINGS
TABLE OF CONTENTS**

2.02	GALVANIC ANODES.....	21
2.03	READY-MIXED CONCRETE.....	23
2.04	FLUSH-MOUNTED TEST STATION box	23
2.05	TERMINAL BOARDS.....	23
2.06	MECHANICAL LUGS.....	23
2.07	SHUNTS.....	23
2.08	CONDUIT AND FITTINGS.....	23
2.09	CAUTION TAPE.....	24
2.10	WIRES.....	24
2.11	WIRE IDENTIFICATION TAGS.....	24
2.12	EXOTHERMIC WELDS.....	24
2.13	EXOTHERMIC WELD COATING.....	25
2.14	DIELECTRIC INSULATING FLANGE KITS	25
2.15	Pvc pipe for isolation of new from existing pipe.....	26
PART 3	EXECUTION	26
3.01	MATERIAL AND EQUIPMENT STORAGE.....	26
3.02	EXCAVATION AND BACKFILL.....	26
3.03	SURFACE GROUND BED FOR GALVANIC ANODES	26
3.04	TEST STATIONS	27
3.05	WIRES.....	27
3.06	WIRE IDENTIFICATION TAGS.....	28
3.07	EXOTHERMIC WELD CONNECTIONS.....	28
3.08	JOINT BONDS.....	29
3.09	DIELECTRIC INSULATING FLANGE KITS	29
3.10	Pvc pipe for isolation of new from existing pipe.....	30
3.11	WIRE CONNECTIONS.....	30
3.12	RESTORATION SERVICES.....	30
3.13	ISOLATION TESTING ON INSULATING JOINTS.....	31
3.14	ISOLATION TESTING ON pvc pipe mechanical joints.....	31
3.15	CONTINUITY TESTING	31
3.16	FINAL SYSTEM CHECKOUT	32
SECTION	31 80 00 - TRENCH EXCAVATION, BEDDING, AND BACKFILL	35
PART 1	GENERAL.....	35
1.01	SCOPE OF WORK.....	35
PART 2	MATERIALS.....	35
2.01	BEDDING MATERIAL	35
2.02	AGGREGATE BASE (CLASS 2).....	35
2.03	DRAIN ROCK.....	35

**MID-PENINSULA WATER DISTRICT
STANDARD SPECIFICATIONS AND DRAWINGS
TABLE OF CONTENTS**

2.04	PAVEMENT.....	35
PART 3	EXECUTION	35
3.01	CONSTRUCTION ACROSS IMPROVED AREAS.....	35
3.02	UNDERGROUND OBSTRUCTIONS.....	36
3.03	TRENCH EXCAVATION.....	36
3.04	TRENCH BACKFILL.....	40
SECTION	32 10 00 - PAVING, RESTORATION, AND RESURFACING WORK	43
PART 1	GENERAL.....	43
1.01	SCOPE OF WORK.....	43
1.02	SUBMITTALS	43
PART 2	MATERIALS.....	43
2.01	AGGREGATE BASE/SURFACING	43
2.02	ASPHALT CONCRETE	43
2.03	ASPHALT BINDER	43
2.04	TACK COAT.....	43
2.05	TEMPORARY PAVING.....	43
2.06	SLURRY SEAL.....	44
2.07	STRIPING AND PAVEMENT MARKINGS.....	44
PART 3	EXECUTION	44
3.01	AGGREGATE BASE COURSE.....	44
3.02	AGGREGATE SURFACING COURSE.....	44
3.03	TACK COAT.....	44
3.04	TEMPORARY PAVING.....	44
3.05	ASPHALT CONCRETE	45
3.06	SLURRY SEAL.....	45
3.07	TRAFFIC STRIPING.....	45
3.08	DAMAGE REPAIR.....	45
SECTION	33 14 10 - ABANDONMENT OF EXISTING WATER MAIN AND FACILITIES	47
PART 1	GENERAL.....	47
1.01	SCOPE OF WORK.....	47
PART 2	MATERIALS.....	47
2.01	AGGREGATE BASE.....	47
2.02	PAVEMENT REPLACEMENT.....	47

**MID-PENINSULA WATER DISTRICT
STANDARD SPECIFICATIONS AND DRAWINGS
TABLE OF CONTENTS**

PART 3	EXECUTION	47
3.01	ABANDONMENT OF EXISTING WATER MAIN & FACILITIES.....	47
SECTION	33 14 13 – WATER MAIN.....	49
PART 1	GENERAL.....	49
1.01	SCOPE OF WORK.....	49
1.02	SUBMITTALS	49
PART 2	MATERIALS.....	49
2.01	DUCTILE IRON (DI) PIPE	49
2.02	PVC PIPE.....	50
2.03	THRUST RESTRAINTS.....	52
2.04	THRUST BLOCKS.....	52
2.05	PIPE CONNECTORS.....	52
2.06	HARDWARE.....	53
2.07	TUBING AND FITTINGS.....	53
2.08	MARKER TAPE FOR BURIED PIPING	53
2.09	TRACER WIRE	53
PART 3	EXECUTION	54
3.01	TRENCH EXCAVATION, BEDDING AND BACKFILL.....	54
3.02	EXISTING UTILITIES AND STRUCTURES	54
3.03	HANDLING AND DISTRIBUTION OF MATERIALS	54
3.04	INSTALLATION OF BURIED PRESSURE PIPING	54
3.05	INSTALLATION OF ABOVE GROUND EXPOSED PRESSURE PIPING.....	59
3.06	CASING.....	60
3.07	PRESSURE PIPE acceptance tests.....	60
3.08	FLUSHING AND DECHLORINATION.....	61
3.09	CUTTING AND DISPOSAL OF EXISTING ASBESTOS CEMENT PIPE.....	62
SECTION	33 14 20 - VALVES AND APPURTENANCES	63
PART 1	GENERAL.....	63
1.01	SCOPE OF WORK.....	63
1.02	SUBMITTALS	63
PART 2	MATERIALS.....	63
2.01	GENERAL.....	63
2.02	GATE VALVES	63
2.03	GATE VALVE EXTENSION.....	64
2.04	HYDRANTS	65

**MID-PENINSULA WATER DISTRICT
STANDARD SPECIFICATIONS AND DRAWINGS
TABLE OF CONTENTS**

2.05	COMBINATION AIR VALVES	65
2.06	METER VALVES AND COUPLINGS	65
2.07	CORPORATION STOPS.....	66
2.08	SERVICE SADDLES	66
2.09	BLOWOFF ASSEMBLY.....	66
2.10	BACKFLOW PREVENTER.....	66
2.11	VALVE AND METER BOXES	67
2.12	PRESSURE REDUCING VALVE.....	67
PART 3	EXECUTION	68
3.01	VALVES INSTALLATION	68
3.02	VALVE AND METER BOX INSTALLATION.....	68
3.03	INSTALLATION OF SERVICES	69
3.04	INSTALLATION OF FIRE HYDRANTS.....	69
3.05	BLOW-OFF ASSEMBLY INSTALLATION	70
3.06	COMBINATION AIR VALVES INSTALLATION.....	70
3.07	INSTALLATION OF BACKFLOW PREVENTERS	70

SECTION 01 33 00 - SUBMITTALS

PART 1 GENERAL

1.01 SCOPE OF WORK

- A. Work included in this section consists of furnishing various submittal items as listed herein, as required for the work.

1.02 SUBMITTAL PROCEDURE

- A. The Contractor shall deliver all applicable submittals listed in the schedule included in this section a minimum of twenty (20) days before the anticipated start of construction. This time limit shall not apply to those items to be furnished during the course of the work or near or at the conclusion of the work such as test reports and record drawings. Two (2) hard copies or electronic files in PDF format of all submittal materials shall be furnished. Prior to installation of materials, the Contractor shall submit two (2) hard copies or electronic files in PDF format of corrected final submittal material. Installation shall not commence until submittal material has been reviewed by the District and final submittals have been delivered.
- B. The Contractor shall use the following procedure in submitting and processing submittals for review by the District:
 - 1. Each submittal item shall be forwarded to the District with an individual transmittal letter or form. The letter or form shall include the following items:
 - a. Project name.
 - b. Submittal number.
 - c. Description of submittal item.
 - d. Specification section and drawing references.
 - e. Certification by the Contractor's representative that the submittal is complete and correct.
- C. When required in a specific specification section, a "Letter of Compliance" shall be furnished stating that material and/or equipment furnished complies with the specifications.
- D. The District reserves the right to require submittals in addition to those called for herein.

1.03 SHOP DRAWINGS

- A. The term "shop drawings" includes drawings, diagrams, layouts, schematics, descriptive literature, illustrations, furnished by Contractor to explain in detail specific portions of the work required by the contract.
- B. The Contractor shall coordinate all such drawings, and review them for legibility, accuracy, completeness and compliance with contract requirements and shall so indicate that such coordination and review has been done by signing the transmittal letters. Shop drawings submitted to the District without evidence of Contractor's review will be returned for resubmission.
- C. Review by the District shall not relieve the Contractor from responsibility for any errors or omissions in such drawings, nor from responsibility for complying with requirements of this contract. If shop drawings show variations from contract requirements, the Contractor shall describe such variations in writing, separate from the drawings, at time of submission. All such variations must be approved by the District.
- D. In these Standard Specifications, whenever the trade name of a product or the name of a manufacturer appears, it shall be understood to specify the product so identified and no equivalent is allowed. If the District Standards Specifications allow for use of an equivalent data may be submitted by the Contractor for a period of fifteen (15) days from receipt of the Notice to Proceed to substantiate a request for substitution as an equivalent item.
- E. Wherever in these Standard Specifications, or in any orders that may be given by the District pursuant to or supplementing the specifications, it is provided that the Contractor shall furnish materials for which no detailed specifications are set forth, the materials shall conform to accepted quality standards for materials of the kind required, with due consideration for the use to which they are to be put.

1.04 SAMPLES AND TESTS

- A. The source supply of each material furnished shall be approved by the District, unless the District advises the Contractor to the contrary at least ten (10) calendar days prior to the time when delivery is started, of any of the material used in work. Representative preliminary samples of the character and quality prescribed and the manufacturer's test certificates pertaining thereto shall be submitted by the Contractor for all materials to be used in work, as required by these Standard Specifications or as requested by the District.
- B. All tests of materials will be made in accordance with commonly recognized standards of national organizations, and such special methods and tests as are prescribed in these project specifications. The approval of any material on the basis of sample tests and/or certificates will be considered as general approval only, and will not constitute a waiver of the District's right to demand full compliance with the Contract requirements. After delivery of materials to the job, the District will make such check tests as deemed necessary in each instance, and may reject materials, equipment, or accessories which

fail to meet the check tests, even though such materials have previously been given general approval.

- C. Laboratory test reports shall cite the contract requirements, the test of analysis procedures used, the actual test results, and includes a statement that the item tested or analyzed conforms or fails to conform to specification requirements. All test reports shall be signed by a representative of the testing laboratory authorized to sign certified test reports.
- D. The cost of all testing will be borne by the District, except for the following situations: (1) The Contractor shall assume all costs of retesting materials which fails to meet Contract requirements; (2) The Contractor shall assume all costs of testing materials offered in substitution of those found to be deficient; (3) The Contractor shall assume all costs of testing materials offered in lieu of specified materials, to prove their quality equivalence.

1.05 CERTIFICATES

- A. For those items called for in individual sections of these Standard Specifications or shown on project drawings, furnish certificates from manufacturers, suppliers, or other certifying that materials or equipment being furnished under the contract comply with the requirements of these Standard Specifications.

1.06 PROGRESS SCHEDULES

- A. The Contractor shall submit a schedule at the preconstruction meeting for the project showing the estimated startup and completion date for each element of the work, in conformance with the requirements of the Standard Specifications.

1.07 TRAFFIC CONTROL PLAN

- A. The Contractor shall notify the City of Belmont Public Works Department, the City of Belmont Fire Department, the City of Belmont Police Department, the City of San Carlos Public Works Department, City of San Carlos Fire Department, County of San Mateo Fire Protection Services, County of San Mateo Public Works or/and County of San Mateo Sheriff's Office (if applicable) at least 72 hours in advance whenever lane closures are planned. Such notification shall include the details and location of such closure, its anticipated duration and traffic control and signing to be used during such closure.

1.08 RECORD DRAWINGS

- A. Using colored ink, each Contractor shall make changes on a set of clean prints. Indicate all changes and revisions to the original design that affect the permanent structures and will exist in the completed work. Reference underground utilities to semi-permanent or permanent physical objects. Reference water, sewer, telephone, storm drain, gas, and electric lines to corners of buildings and survey markers.

- B. The record drawings shall be kept current. Project record drawings are the property of the District. The original hard copies of the record drawings shall be delivered to the District before project closeout.

1.09 SUBMITTAL SCHEDULE

- A. The list below is a general representation of materials to be used on the project. The Contractor is responsible for reviewing each individual specification section for specific requirements to ensure all material information is submitted and reviewed.

Section No.	Item
	Safety Plan per the General Standard Specifications
01 50 00	Staging Plan Best Management Practices Plan
01 52 00	Traffic Control Plan
01 57 23	Water Pollution Control Plan
01 70 00	Tests Certificates and Guarantees Record Drawings
03 30 00	Concrete Rebar
31 80 00	Subgrade Material Bedding Material Aggregate Base Written Shoring Safety Plan (prepared by a registered Civil Engineer)
13 47 13	Catalog Data on Anodes Cables Cables to Pipe Connections Test Stations Terminal Boxes Shunts Cable Warning Tape, Identification Tags Insulating Flange Materials Thermite Welds Weld Coating
32 10 00	Aggregate Base Aggregate Surfacing Asphaltic Concrete Bonding Coat and Crack Seal Temporary Paving Controlled Density Fill Type II Slurry Seal Striping Materials (striping and markers)

33 14 13	Ductile Iron Pipe PVC Pipe Thrust-Resistant Restraint for Ductile Iron Pipe and/or PVC Pipe Thrust Blocks Hardware Tubing and Fittings V-Bio Polyethylene Encasement and tape Marker Tape for Buried Piping Tracer Wire Disinfection Plans Disposal of Chlorine Water
33 14 20	Gate Valves Gate Valve Marker Post Gate Valve Extensions Pressure Reducing Valves Blow-Off Assembly Materials Service Connection Fittings and Valves Combination Air Valve Materials Valve and Meter Boxes Hydrants Assembly Materials

PART 2 MATERIALS - NONE

PART 3 EXECUTION – NONE

*****END OF SECTION*****

INTENTIONALLY LEFT BLANK

SECTION 01 45 00 - QUALITY CONTROL

PART 1 GENERAL

1.01 SCOPE OF WORK

- A. Work included under this section consists of performing or conforming to quality control procedures and requirements as listed herein and in the various sections that comprise these Standard Specifications.

1.02 GENERAL QUALITY

- A. All material shall be new and of a quality equivalent to that specified.
- B. The work shall be executed in conformity with the best accepted standard practice of the trade so as to contribute to maximum efficiency of operation, accessibility and appearance, and minimum cost of maintenance and construction of future alterations and additions.

1.03 QUALITY IN ABSENCE OF DETAILED SPECIFICATIONS

- A. Whenever the Contractor shall furnish materials or manufactured articles or shall do work for which no detailed specifications are set forth, the materials or manufactured articles shall be of the normal commercial grade in quality and workmanship obtained from firms normally furnishing such materials or equipment or, if not ordinarily carried in stock, shall conform to the usual standards for first-class materials or articles of the kind required with due consideration of the use to which they are to be put. In general, the work performed shall conform with the intent to secure the normal commercial standard of construction and equipment of the work as a whole or in part.

1.04 DEFECTIVE MATERIALS

- A. All materials not conforming to these Standard Specifications shall be considered defective, and all such materials, whether in place or not will be rejected and shall be immediately removed from the site of the work unless otherwise permitted to remain by the District. Rejected materials, the defects of which have been subsequently corrected, shall not be used until approval in writing has been obtained from the District. Upon failure of the Contractor to comply with any order of the District made under the Standard Specifications of this article, the District shall have the authority to remove and replace defective materials and to deduct the cost of same from any monies due or to become due the Contractor.

1.05 GUARANTEE

- A. All materials, and workmanship shall be guaranteed by the Contractor for a period of two (2) years from the date of initial operation or the date of acceptance thereof, whichever is later, against all defects that might render the work unsatisfactory for the intended

purpose. Defective materials and workmanship occurring during the guarantee period shall be replaced by the Contractor at his expense, together with the repair or replacement of any adjacent work which may be damaged or displaced in the process.

- B. In addition to the above guarantee, the Contractor shall assign to the District all material guarantees issued by manufacturers or subcontractors which guarantees extend beyond the two (2) year period stipulated.

PART 2 MATERIALS - NONE

PART 3 EXECUTION - NONE

*****END OF SECTION*****

SECTION 01 70 00 - PROJECT CLOSEOUT

PART 1 GENERAL

1.01 SCOPE OF WORK

- A. Work included under this section consists of conforming to the job completion-related requirements of other sections in these Standard Specifications and of furnishing various materials needed to complete the project.

1.02 SUBMITTALS

- A. Tests
 - 1. Submit any test results done during the course of the work and not previously submitted in accordance with applicable sections of these Standard Specifications.
- B. Certificates and Guarantees
 - 1. Furnish all certificates and/or guarantees as required by individual Standard Specifications Sections and in accordance with applicable sections of these Standard Specifications.
- C. Record Drawings
 - 1. Furnish record drawings.

1.03 INSPECTION

- A. Final Inspection
 - 1. Submit written certification that project, or designated portion of project, is substantially complete, and request, in writing, a final inspection. The District will make an inspection within ten (10) days of receipt of the request.
 - 2. Should the District determine that the work is substantially complete, the District will prepare a punch list of deficiencies that do not preclude operation and use of the facility; however, final payment will be withheld until all deficiencies are corrected and all close-out requirements of the encroachment permits are met.
 - 3. Prior to the District accepting the project, the Contractor shall perform a final sweep using a regenerating air type street sweeper along the project limits fourteen (14) days after the paving and striping operations. Work shall be coordinated with the District inspector.
 - 4. Until receipt of a letter of final acceptance, the Contractor shall be responsible for the work.

B. Post Construction Inspection

1. Prior to expiration of the performance bond, and approximately twenty-three (23) months from date of final acceptance, the District will inspect project to determine whether corrective work is needed. The Contractor will be notified in writing of any deficiencies. The Contractor must begin corrective work on the noted deficiencies within ten (10) days after receipt of notification.

PART 2 MATERIALS - NONE

PART 3 EXECUTION

3.01 CLEANING

- A. Cleanup and cleaning shall be done in accordance with applicable sections of these Standard Specifications.

*****END OF SECTION*****

SECTION 03 30 00 - CAST-IN-PLACE CONCRETE

PART 1 GENERAL

1.01 SCOPE OF WORK

- A. Work included under this section consists of furnishing and installing all materials, supplies, equipment, tools, transportation, and facilities, and performing all labor and services necessary for, required in connection with, or properly incidental to furnishing and installing cast-in-place concrete work as described in this section of the specifications, shown on the accompanying drawings, or reasonably implied therefrom except as hereinafter specifically excluded.
- B. Defective Work
 - 1. Work considered to be defective may be ordered by the District to be replaced, in which case the Contractor shall remove and replace the defective work at their expense.
- C. Applicable Standards
 - 1. All concrete shall be mixed, delivered, placed, finished, and cured in accordance with Sections 51 - Concrete Structures, and Section 90 - Concrete, of the latest requirements of Caltrans Standard Specifications, and with American Concrete Institute (ACI) 301-11 - Standard Specifications for Structural Concrete.

1.02 SUBMITTALS

- A. The Contractor shall make submittals for the following as required by Section 01 33 00 Submittals.
 - 1. Mix Designs in compliance with ACI and Caltrans procedures for each class of concrete on the project, and shall show names and brands of all materials, proportions, slump, strength, gradations of coarse and fine aggregates, and location to be used.
 - 2. Manufacturer's data including catalog cuts, drawings, and samples, and letters of compliance as appropriate for epoxies, grout, admixtures, curing compounds, chemical hardeners, moisture barriers, water stops and other items as referenced elsewhere.
 - 3. Shop Drawings and mill certificates for reinforcing steel that show diagrammatic elevations of all walls, footings, columns, beams, slabs, etc. at a scale sufficiently large enough to show clearly the positions and erection marks of reinforcing bars, their dowels, and splices. Shop drawings shall show details for congested areas and connections. Contract drawings shall not be reproduced in whole or in part. Contract drawings modified into shop drawings will be returned without review.

4. Concrete placement schedule shall show all proposed construction joint locations, limits of each placement sequence, the order of placement, any type of joint at each joint location.

B. Approval of Testing Agencies and Reports

1. Any laboratory where testing of materials is to be performed shall receive prior approval from the District. Documentary evidence, satisfactory to the District, that the material has passed the required inspection and testing must be furnished prior to the incorporation of such materials in the work, and rejected materials must be promptly removed from the premises. Lab reports shall show the name of the testing agency, date of testing, types of tests performed, and shall be signed by a principal of the testing agency who is a licensed Civil Engineer in the State of California.

PART 2 MATERIALS

2.01 FORMWORK

- A. Plywood formwork shall be 5/8" plywood, Exterior Type, DFPA Grade "Concrete Form Exterior", or better.

2.02 PORTLAND CEMENT

- A. Portland cement shall conform to ASTM C150 for Type II cement, or Type II-V modified for corrosive environments. Use one standard brand throughout all work.
 1. Fly ash shall conform to ASTM C618 for Class F fly ash. Fly ash percentages shall conform to the latest requirements of Caltrans Standard Specifications.

2.03 ADDITIVES

- A. Water reducing additive shall conform to ASTM C-494 Type A
- B. Water reducing and retarding shall conform to ASTM C-494 Type D
- C. Retarding shall conform to ASTM C-494 Type B

2.04 CONCRETE AGGREGATES

- A. Concrete aggregates shall conform to Section 90 - Concrete of the latest requirements of Caltrans Standard Specifications for hardrock concrete aggregates.

2.05 WATER

- A. Water shall be clean and free from deleterious amounts of acids, alkalies, or organic materials.

2.06 CONCRETE

- A. All structures, minor structures, foundations, and slabs shall be constructed of concrete as specified in Section 51 - Concrete Structures, of the latest requirements of Caltrans Standard Specifications and shall develop a minimum compressive strength of 3,600 psi at twenty-eight (28) days.
- B. The maximum water-cement ration shall be 0.45. If a pozzolan is used in the concrete, the maximum water-cement plus pozzolan ratio shall be 0.45.
- C. The slump shall be 3-inch minimum and 4.5-inches maximum for footing slabs and walls. The slump shall be 1-inch minimum and 4-inches maximum for other slabs, beams, and columns.

2.07 CONTROLLED DENSITY FILL (2-SACK SLURRY)

- A. Controlled density fill shall consist of a fluid, workable mixture of aggregate, cement, and water. The aggregate cement and water shall be proportioned by weight. 188 pounds of cement shall be used for each cubic yard of material. The water content shall be sufficient to produce a fluid, workable mix that will flow and can be pumped without segregation of the aggregate while being placed.
- B. The control density fill should have a twenty-eight (28) day compressive strength of no more than 300 psi. The aggregate (sand) should conform to ASTM C33 (for gradation), and should have a Sand Equivalent of no less than 75.

2.08 BARS

- A. Bars for reinforcing shall be deformed, domestic steel bars conforming to ASTM A706, Grade 60, except that for Minor structures as defined in the latest requirements of Caltrans Standard Specifications, ASTM A615, Grade 60 may be used.

2.09 WIRE

- A. Wire for tying reinforcement in place shall be No. 18 or heavier, AWG black annealed.

2.10 THRUST BLOCKS

- A. Thrust blocks shall be constructed of 2,000 psi, high early strength, minor concrete, as defined in Section 90 – Concrete, of the latest requirements of Caltrans Standard Specifications with a minimum 505 pounds of cementations material per cubic yard.

PART 3 EXECUTION

3.01 FORMWORK

- A. Forms shall be designed and constructed in accordance with the requirements of Section 51 - Concrete Structures, of the latest requirements of Caltrans Standard Specifications, and ACI 301-11.
- B. The forms shall be smooth, mortar-tight, true to the required lines and grades, and of sufficient strength to resist springing out of shape during the placing and vibrating of concrete. All dirt, chips, sawdust, and other foreign matter shall be completely removed before concrete is deposited therein. Forms previously used shall be thoroughly cleaned of all dirt, mortar, and foreign matter before being reused. Before concrete is placed in forms, all inside surfaces of the forms shall be thoroughly coated with a form sealer. The form sealer shall be of high penetrating quality leaving no film on the surface of the forms that can be absorbed by the concrete or be incompatible with concrete paint.
- C. All exposed sharp edges shall be rounded or chamfered with triangular fillets, 3/4 -inch, unless shown otherwise on the drawings.
- D. Forms shall be removed in such a manner and at such time so as to ensure the complete safety of the structure and proper curing of the concrete.

3.02 INSTALLATION OF REINFORCING STEEL

- A. Reinforcing steel shall be cleaned, fabricated, placed, tied, and supported in accordance with the ACI detailing manual, SP-66(04), and Section 52 – Reinforcement, of the latest Caltrans Standard Specifications.
- B. Steel reinforcement shall be accurately placed and shall be supported and secured against displacement by the use of adequate and proper supporting and spacing devices, tie wires, etc., so that it will remain in its correct location in the finished work. No supporting devices shall be used that will impede the placement of concrete.
- C. The clear spacing between parallel bars shall be not less than 1-1/2 times the normal diameter of the maximum size aggregate, and in no case less than 1-1/2-inches except at splices which shall be wired together. Concrete cover, and other reinforcing spacing requirements, shall conform to the latest requirements of the ACI 318 2011 version.
- D. Reinforcing steel shall extend to the far face of the concrete and terminate in a 90° hook.
- E. Lap splice lengths shall be per the latest edition of ACI 318, dependent on bar orientation and confinement.

3.03 PLACEMENT OF CONCRETE

- A. Place concrete so that a uniform appearance of surfaces will be obtained, and the concrete will be free of all rock pockets, honeycombs, and voids.

3.04 CURING

- A. Freshly deposited concrete shall be protected from premature drying and excessively hot or cold temperatures, and shall be maintained with minimal moisture loss at a relatively constant temperature for the period of time necessary for the hydration of the cement and proper hardening of the concrete.

3.05 CONSTRUCTION JOINTS

- A. Joints not shown on the Drawings shall be so made and located as to least impair the strength of the structure. A pour schedule for each structure showing all construction joints shall be submitted to the District for review.
- B. The surfaces of all concrete joints shall be thoroughly cleaned and all laitance removed by sandblasting. In preparation for the next pour, the joints shall be dampened. Where directed by the District, joints shall be intentionally roughed as described in the Standard Specifications to amplitude of 1/4-inch.

3.06 EXPANSION JOINTS

- A. Pre-molded expansion joint material shall be installed where concrete walks abut buildings, walls, and curbs, where shown on the Drawings and at 20'-0" on centers maximum, where not specifically shown.

3.07 EMBEDDED ITEMS

- A. All sleeves, inserts, anchors, ladders, and other embedded items required for adjoining work or for its support shall be placed prior to concreting. Embedded items shall be positioned accurately and supported against displacement. Voids in sleeves, inserts, and anchor bolt slots shall be filled temporarily with a readily removable material to prevent entry of concrete into the voids.

3.08 REPAIR OF SURFACE DEFECTS

- A. All tie holes and all repairable defective areas shall be patched immediately after form removal in accordance with the applicable provisions of Section 51 - Concrete Structures, of the latest requirements of Caltrans Standard Specifications.

B. Finishes

1. Schedule of Finishes

<u>Element</u>	<u>Finish</u>
Walls not exposed	Ordinary Surface Finish
Exposed walls	Class 1 Finish
Exposed slabs	Broom finish

2. Ordinary and Class 1 Surface Finishes

- a. Shall conform to latest Standard Specifications.

3. Broom Finish

- a. Concrete shall first be finished with power floats, then with power trowels, and final by hand trowels before it is given a coarse, scored texture by drawing a broom, or burlap belt, across the slab surface.

3.09 CONCRETE COMPRESSIVE STRENGTH TESTS

- A. Concrete will be tested and inspected as work progresses. One compressive strength test shall be made for each pour and as described in the Standard Specifications. One complete test shall consist of making three (3) cylinders in accordance with ASTM C31, storing the cylinders for twenty-four (24) hours at the pour site, delivering the cylinders to the testing laboratory, testing one cylinder at seven (7) days and the other two (2) cylinders at twenty-eight (28) days in accordance with ASTM C39. Four copies of certified test results shall be forwarded to the District upon completion of the testing.

3.10 CONCRETE SLUMP TESTS

- A. Each pour shall be tested for slump at the beginning of the pour, at the time the sample for the strength test is taken, and whenever the consistency of the concrete appears to vary. The test shall conform to ASTM C143.

*****END OF SECTION*****

SECTION 13 47 13 – CATHODIC PROTECTION OF DUCTILE IRON WATER MAIN

PART 1 GENERAL

1.01 SCOPE OF WORK

- A. The Work of this Section includes providing a complete galvanic anode cathodic protection (CP) system for ductile iron pipelines as outlined in this Section and the Standard Drawings.
- B. Electrical isolation of the structures from adjacent metallic structures, , structures of dissimilar metal or dissimilar coatings, conduits, and all other metallic components that may impact the operation of the CP system.
- C. Electrical bonding of all non-insulated, non-welded pipe joints and mechanical joints.
- D. Installation of galvanic anodes, insulating joints, test stations, other components associated with the CP system, and all other work described herein and on the Standard Drawings.
- E. Testing of CP system during installation.
- F. Cleanup and restoration of work site.
- G. Final System Checkout: Testing of CP system after installation and backfilling.

1.02 REQUIREMENTS

- A. If the products installed as part of this Section are found to be defective or damaged or if the Work of this Section is not in conformance with these Specifications, then the products and Work shall be corrected at the Contractor's expense.
- B. Any retesting required due to inadequate installation or defective materials shall be paid for by the Contractor at no additional cost to the District.
- C. The Work also requires coordination of assembly, installation, and testing between the pipeline contractor and any CP material supplier or subcontractor.
- D. All electrical Work shall be in accordance with NEC and local requirements.

1.03 REFERENCED SPECIFICATIONS, CODES AND STANDARDS

- A. The Work of this Section shall comply with the current editions of the codes and standards referenced in this specification, including the following:
 - 1. AASHTO American Association of State Highway and Transportation Officials
 - a. H20 Specification for Highway Bridges

2. ASTM ASTM International
- a. A123 Standard Specification for Zinc (Hot-Dip Galvanized) Coatings on Iron and Steel Products
 - b. A615 Standard Specification for Deformed and Plain Carbon-Steel Bars for Concrete Reinforcement
 - c. B3 Standard Specification for Soft or Annealed Copper Wire
 - d. B8 Standard Specification for Concentric-Lay-Stranded Copper Conductors, Hard, Medium-Hard, or Soft
 - e. B80 Standard Specification for Magnesium-Alloy Sand Castings
 - f. B187 Standard Specification for Copper, Bus Bar, Rod, and Shapes and General Purpose Rod, Bar, and Shapes
 - g. B418 Standard Specification for Cast and Wrought Galvanic Zinc Anodes
 - h. B843 Standard Specification for Magnesium Alloy Anodes for Cathodic Protection
 - i. C94 Standard Specification for Ready-Mixed Concrete
 - j. D1000 Standard Test Methods for Pressure-Sensitive Adhesive-Coated Tapes Used for Electrical and Electronic Applications
 - k. D1248 Standard Specification for Polyethylene Plastics Extrusion Materials for Wire and Cable
 - l. D1785 Standard Specification for Poly (Vinyl Chloride) (PVC) Plastic Pipe, Schedules 40, 80, and 120.
 - m. D2220 Standard Specification for Poly (Vinyl Chloride) Insulation for Wire and Cable, 75°C Operation
 - n. D3005 Standard Specification for Low-Temperature Resistant Vinyl Chloride Plastic Pressure-Sensitive Electrical Insulating Tape
 - o. D4388 Standard Specification for Nonmetallic Semi-Conducting and Electrically Insulating Rubber Tapes

- p. D6386 Standard Practice for Preparation of Zinc (Hot-Dip Galvanized) Coated Iron and Steel Product and Hardware Surfaces for Painting
- q. G97 Standard Test Method for Laboratory Evaluation of Magnesium Sacrificial Anode Test Specimens for Underground Applications
- 3. AWWA American Water Works Association
 - a. C217 Petrolatum and Petroleum Wax Tape Coatings for the Exterior of Connections and Fittings for Steel Water Pipelines
- 4. NSF National Sanitation Foundation
 - a. NSF 61 Drinking Water System Components
- 5. NACE International, the Corrosion Society
 - a. RP0375 Field-Applied Underground Wax Coating Systems for Underground Pipelines: Application, Performance, and Quality Control
 - b. SP0169 Control of External Corrosion on Underground or Submerged Metallic Piping Systems
 - c. SP0286 Electrical Insulation of Cathodically Protected Pipelines
 - d. TM0497 Measurement Techniques Related to Criteria for Cathodic Protection on Underground or Submerged Metallic Piping Systems
- 6. NFPA National Fire Protection Association
 - a. NFPA 70 National Electric Code (NEC)
- 7. NEMA National Electrical Manufacturers Association
 - a. TC2 Electrical Polyvinyl Chloride (PVC) Tubing and Conduit
 - b. TC3 PVC Fittings for Use with Rigid PVC Conduit and Tubing
- 8. UL Underwriters Laboratories
 - a. 467 Grounding and Bonding Equipment
 - b. 514B Fittings for Cable and Conduit

- B. Whenever the Standard Drawings or these Specifications require a higher degree of workmanship or better quality of material than indicated in the above codes and standards, these Standard Drawings and Specifications shall prevail.

1.04 QUALITY ASSURANCE

- A. Installation of the CP equipment shall be performed by individuals having at least five years of experience in the installation of the CP equipment described herein.
- B. All testing required to be performed by a “Corrosion Technician” shall be performed by a NACE certified Corrosion Technician under the supervision of a Corrosion Engineer. A Corrosion Technician is a NACE CP2 (CP Technician), CP3 (CP Technologist), or CP4 (CP Specialist). A Corrosion Engineer is a Registered Professional Corrosion Engineer or a NACE CP4 (CP Specialist).

1.05 SUBMITTALS

- A. The following shall be submitted to the District prior to any equipment installation.
 - 1. Catalog cuts, bulletins, brochures, or data sheets for all materials specified herein.
 - 2. Statement that the equipment and materials proposed meet the Specifications and the intent of the Specifications.
 - 3. Statement of installation experience required.
 - 4. Schedule, including the expected start date and planned completion date.
- B. The following shall be submitted to the District after completion of the Work.
 - 1. Wire connection testing.
 - 2. Insulating joint testing, before and after backfilling.
 - 3. Joint bond testing, before and after backfilling.

1.06 INTERFERENCE AND EXACT LOCATIONS

- 1. The locations of CP equipment, test stations, devices, outlets, and appurtenances, as indicated are approximate only. Exact locations shall be determined by the District in the field.
- 2. The Contractor shall field verify all data and final locations of work done under other Sections of the Specifications required for placing of the electrical work.
- 3. In case of interference with other work, foreign pipeline, or erroneous locations with respect to equipment or structures, the Contractor shall furnish all labor and materials necessary to complete the Work in an acceptable manner to the District. Deviations

from the Standard Drawings and Specifications shall be submitted to the District for approval.

PART 2 MATERIALS

2.01 GENERAL

- A. All materials installed must be new. All equipment and materials supplied shall be similar to that which has been in satisfactory service for at least 5 years.
- B. All materials in contact with potable water shall be NSF 61 approved.

2.02 GALVANIC ANODES

- A. High-potential magnesium anodes: Cast magnesium anodes shall conform to ASTM B843 Type M1C. Anodes shall have an open circuit potential of -1.70 volts or more electronegative and a current efficiency of at least 48% when tested in accordance with ASTM G97. Anodes shall have the following size, form, and shape. Anodes shall be manufactured by Farwest, Corpro, Mesa, Matcor, or equivalent.

Ingot				Packaged		
Weight (lb)	Width (inch)	Height (inch)	Length (inch)	Weight (lb)	Diameter (inch)	Length (inch)
5	3 to 4	3 to 4	7 to 8	14 to 17	5 to 6	13 to 14
9	3 to 4	3 to 4	13 to 14	24 to 27	6	17
17	3 to 4	3 to 4	25 to 26	42 to 45	6 to 7	29 to 30
20	2 to 3	2 to 3	56 to 60	70	5 to 6	62.5 to 66
32	5 to 6	5 to 6	19 to 21	70	8	28 to 30
40	3 to 4	5 to 6	60	100	6 to 7	64 to 66
48	5 to 6	5 to 6	30 to 31	100 to 105	8	34 to 38
60	4 to 5	4	60	126 to 130	6 to 7	64

- B. Standard-potential magnesium anodes: Cast magnesium anodes shall conform to ASTM B843 Type AZ63B (commonly known as H1A). Anodes shall have an open circuit potential of -1.53 to -1.55 volts or more electronegative and current efficiency of 45 to 55% when tested in accordance with ASTM G97. Anodes shall have the following size, form, and shape. Anodes shall be manufactured by Farwest, Corpro, Mesa, Matcor, or equivalent.

Ingot				Packaged		
Weight (lb)	Width (inch)	Height (inch)	Length (inch)	Weight (lb)	Diameter (inch)	Length (inch)
5	3 to 4	3 to 4	7 to 10	13 to 16	5 to 6	11 to 14
9	3 to 4	3 to 4	13 to 14	24 to 27	5 to 7	17 to 20
17	3 to 4	3 to 4	17 to 26	42 to 45	6 to 8	19 to 29
20	2 to 3	2 to 3	56 to 57	70	6 to 7	62
32	5 to 6	5 to 6	20 to 21	68 to 70	8 to 9	28 to 30
48	5 to 6	5 to 6	30 to 31	105	7 to 8	38
60	4 to 5	4 to 5	57 to 61	126	7 to 8	64

- C. Galvanic anodes shall be pre-packaged in a cloth bag containing backfill of the following composition: 75% gypsum, 20% bentonite, and 5% sodium sulfate. The anodes size and location, as shown on the Project Plans, shall be determined by the District.

D. Anode lead wire:

1. The wire size and type, attached to the anodes, shall be as specified on the Standard Drawing. The anode lead wire shall conform to the Section 2.10 of this Standard Specification.
2. Connection of wire to the anode shall have a pulling strength that exceeds the wire's tensile strength.
3. Anode lead wires shall be of one continuous length, without splices, unless otherwise indicated on the Standard Drawings, from the anode connection to the test station.

2.03 READY-MIXED CONCRETE

- A. Ready-mixed concrete shall be in accordance with Section 03 30 00 of this Standards and Specification.

2.04 FLUSH-MOUNTED TEST STATION BOX

- A. Flush-mounted test station boxes shall be Christy G05 Utility Boxes, manufactured by Oldcastel Precast.
- B. Traffic box covers for test stations shall be cast iron with welded bead legend and labeled "ANODE".

2.05 TERMINAL BOARDS

- A. Terminal boards shall be made of 1/4-inch thick phenolic plastic and sized as indicated on the Standard Drawings.
- B. Connection hardware shall be brass or bronze. All connections shall be double nutted bolts with serrated lock washers.
- C. Copper bus bar shall be 1/8-inch thick and sized to fit. The copper bus bar shall be per ASTM B187 with 98% conductivity.

2.06 MECHANICAL LUGS

- A. Mechanical lugs shall be brass or copper with a brass, copper, or stainless steel set screw. Tin plating on the lugs is optional. Aluminum lugs shall not be permitted. Zinc-plated steel set screws shall not be permitted. The lug shall be listed per UL 467, suitable for direct burial, and appropriately sized for the incoming wires. The lug shall be ILSCO Type XT-6DB, Burndy GKA8C, or an approved equivalent.

2.07 SHUNTS

- A. Shunts shall be selected by the size indicated on the Standard Drawings.
- B. 0.01-ohm, 6-amp shunts shall be manganin wire type, as indicated. Shunts shall be Type RS, as manufactured by Holloway, or equivalent.

2.08 CONDUIT AND FITTINGS

- A. The minimum conduit size shall be 2 inch unless otherwise indicated. Refer to NFPA 70 (NEC) for additional conduit size requirements.
- B. Conduit and fittings placed below grade shall be Schedule 80 PVC in accordance with NEMA TC2 and NEMA TC3.

- C. Conduit and fittings placed above grade shall be rigid steel. Rigid Steel conduit shall be galvanized and conform to UL 6.
- D. Conduit clamps shall be 316 stainless steel.
- E. Fittings for use with rigid steel conduit shall be galvanized cast ferrous metal, with gasketed covers, Crouse Hinds Condulets, Appleton Unilets, or equivalent. Rigid metallic conduit fittings shall be galvanized, conform to NEMA FB 1, and listed to UL 514B.
- F. Union couplings for conduit shall be Erickson or Appleton Type EC, 0-Z Gedney 3-piece Series 4, or equivalent.

2.09 CAUTION TAPE

- A. The caution tape shall be an inert plastic film designed for prolonged underground use. The caution tape shall be a minimum of 3 inches wide and a minimum of 5 mils thick.
- B. The caution tape shall be continuously printed over the entire length with the wording "CAUTION: CATHODIC PROTECTION CABLE BURIED BELOW."
- C. The wording shall be printed using bold black letters. The color of the tape shall be red.

2.10 WIRES

- A. Conductors shall consist of stranded copper of the gauge indicated on the Standard Drawings. Wire sizes shall be based on American Wire Gauge (AWG). Copper wire shall be in conformance with ASTM B3 and ASTM B8.
- B. Insulation Type and Colors: As shown on the Standard Drawings.
 - 1. High molecular weight polyethylene (HMWPE) wires shall be rated for 600 volts and shall conform to ASTM D1248, Type 1, Class C, Grade 5.

2.11 WIRE IDENTIFICATION TAGS

- A. Wire identification tags shall be the wrap-around type with a high resistance to oils, solvents, and mild acids. Wrap-around markers shall fully encircle the wire with imprinted alpha-numeric characters for pipe identification. The letters and numbers height shall be 3/16 inch at minimum.

2.12 EXOTHERMIC WELDS

- A. Exothermic welds shall be in accordance with the manufacturer's recommendations. Exothermic welds shall be Cadweld manufactured by Erico, Thermoweld manufactured by Burndy, or an approved equivalent.
- B. Prevent molten weld metal from leaking out of the mold, where necessary, by using Duxseal packing manufactured by Johns-Manville, Thermoweld packing material

manufactured by Burndy, Cadweld T403 Mold Sealer manufactured by Erico, or an approved equivalent.

- C. The shape and charge of the exothermic weld shall be chosen based on the following parameters:
 - 1. Pipe material
 - 2. Pipe size
 - 3. Wire size and requirement for sleeves
 - 4. Number of wires to be welded
 - 5. Orientation of weld (vertical or horizontal)

2.13 EXOTHERMIC WELD COATING

- A. After exothermic welding, repair coatings and linings in accordance with the coating and lining manufacturer's recommendation.
- B. For DIP, weld caps with integrated primer shall be used to cover the exothermic weld connecting the wire to the pipe. The weld cap shall be a 10-mil thick durable plastic sheet that has a dome filled with a moldable compound to assure complete encapsulation of the exothermic weld and a layer of elastomeric adhesive with integrated primer. The adhesive and primer shall be compatible with the pipe material and pipe coating material. Adhesion to DIP shall be at least 10 lb/in per ASTM D1000. Weld cap with integrated primer shall be Handy Cap IP manufactured by Royston or equivalent for wire size up to 8 AWG and Handy Cap XL IP manufactured by Royston or equivalent for wire size up to 2 AWG.

2.14 DIELECTRIC INSULATING FLANGE KITS

- A. Dielectric insulating flange kits shall only be used for above ground application.
- B. Insulating flange kits shall include full-faced gaskets, insulating sleeves and washers, and 316 stainless steel bolts, nuts, and washers. The complete assembly shall have a pressure rating equal to or greater than the flanges between which it is installed. Sleeves, gaskets, and insulating washers shall have a minimum dielectric constant of 300 volts per mil. Gaskets shall have a pressure rating of 350 psi. Stainless steel washers shall fit well within the bolt facing on the flange. Insulating washers shall fit within the bolt facing the flange over the outside diameter of the sleeve.
 - 1. Insulating gasket shall be full-faced, Type E, and 1/8-inch thick. Acceptable gasket materials include nitrile faced phenolic, G-10, or a material with equivalent or increased performance. Acceptable seal materials include EPDM, PTFE, or a material with equivalent or increased performance. When used in potable water systems, gasket and seal shall be NSF 61 approved.

2. Insulating sleeves shall be 1/32-inch thick and equal the number of bolts on the flange. Acceptable materials include Mylar, G-10, or a material with equivalent or increased performance.
 3. Insulating washers shall be 1/8-inch thick and equal to twice the number of bolts on the flange. Acceptable materials include G-10 or a material with equivalent or increased performance.
- C. Dielectric insulating flange kits shall be manufactured by Advance Products & Systems Inc., GPT Industries, or an approved equivalent.

2.15 PVC PIPE FOR ISOLATION OF NEW FROM EXISTING PIPE

- A. PVC pipe shall be used for isolation of new DIP to existing CIP underground.
1. The PVC pipe shall be AWWA C-900 DR-14 type.
 2. The PVC pipe shall be minimum three feet in length.
- B. PVC pipe shall be connected to DIP with Megalug mechanical joint and to CIP with a standard mechanical joint.

PART 3 EXECUTION

3.01 MATERIAL AND EQUIPMENT STORAGE

- A. All materials and equipment to be used in construction shall be stored in such a manner to be protected from detrimental effects from the elements. If warehouse storage cannot be provided, materials and equipment shall be stacked well above ground level and protected from the elements with plastic sheeting or another method, as appropriate.

3.02 EXCAVATION AND BACKFILL

- A. Buried wires shall have a minimum cover of 24 inches.
- B. Caution tape shall be installed above buried wire. Caution tape shall be installed a minimum of 6 inches above underground wires and conduits.
- C. Wire identification tags shall be placed on the wires prior to placing wire in conduit or backfilling.

3.03 SURFACE GROUND BED FOR GALVANIC ANODES

- A. Prepackaged anodes shall be installed at the locations indicated on the STANDARD AND Project Plans.
- B. Plastic or paper wrapping shall be removed from the anode prior to lowering the anode into the hole. Anodes shall not be suspended by the lead wires. Damage to the canvas bag, anode-to-wire connection, copper wire, or wire insulation before or during

installation will require replacement of the entire anode assembly. Anodes shall be inspected and approved prior to backfilling.

- C. Anodes shall be backfilled with native soil. Backfilling with native soil shall proceed in 6-inch lifts, compacting the soil around the anode during each lift, until the backfill has reached grade. Upon completion of compaction of backfill to the top of the anode, and prior to filling the hole and compacting the backfill to the surface, a minimum of 10 gallons of fresh water shall be poured into the hole to saturate the prepackaged anode backfill and surrounding soil.
- D. Anode lead wires shall be routed and terminated on the panel board as shown in the Standard Drawings.

3.04 TEST STATIONS

- A. Test stations shall be installed at the approximate locations shown on the Project Plans. The Contractor shall field verify all final locations, subject to acceptance by the District. Test stations shall be located within the public right of way or pipeline easement. Test stations shall be located in areas not subject to vehicular traffic, such as sidewalks, unless otherwise approved by the District.
- B. For flush-mounted test stations, place the bottom of the test box on native soil. Do not place rock, gravel, sand, or debris in the box. Install 2,000 psi high early STRENGTH concrete collar after placement of the test box to finished grade. Provide sufficient sloping in the concrete pad or surrounding pavement to provide drainage away from the test box.
- C. Connect wires to the terminal board as shown on the Standard Drawings. Each wire shall be identified with a permanent wire identifier within 4 inches of the termination. After installation, all wire connections in the test station shall be tested by the Contractor to ensure they meet the requirements herein.

3.05 WIRES

- A. Buried wires shall be laid straight without kinks. Each wire run shall be continuous in length and free of joints or splices, unless otherwise indicated. Care shall be taken during installation to avoid punctures, cuts, or other damage to the wire insulation. Damage to insulation shall require replacement of the entire length of wire at the Contractor's expense.
- B. At least 12 inches of slack (coiled) shall be left for each wire at each flush-to-grade test station. Wire slack shall be sufficient to allow removal of wire extension for testing.
- C. Wire shall not be bent into a radius of less than eight times the overall wire diameter.
- D. The wire conduits must be of sufficient diameter to accommodate the wires. This shall be determined by the number and size of wires in accordance with the applicable codes and standards.

- E. Conduit shall be installed to a minimum depth of 24 inches below grade.
- F. Install caution tape a minimum of 6 inches above buried wire and conduits.

3.06 WIRE IDENTIFICATION TAGS

- A. All wires shall be coded with wire identification tags within 4 inches of the wire end indicating diameter and type of pipe.
- B. Wire identification tags shall be placed on all wires prior to backfilling and installation of test stations.

3.07 EXOTHERMIC WELD CONNECTIONS

- A. Exothermic weld connections shall be installed in the manner and at the locations indicated. Exothermic welds shall be spaced as far away as possible from other exothermic welds, fittings, and circumferential welds.
- B. Coating materials shall be removed from the surface over an area of sufficient size to make the connection and as indicated on the Drawings. The surface shall be cleaned to bare metal per SSPC SP11 (bare metal power tool cleaning) prior to welding the conductor. The use of resin impregnated grinding wheels will not be allowed.
- C. Only enough insulation shall be removed such that the copper conductor can be placed in the welding mold. If the wire conductor diameter is not the same as the opening in the mold, then a copper adapter sleeve shall be fitted over the conductor.
- D. The Contractor shall be responsible for testing all test lead and bond wire welds. The ENGINEER, at his or her discretion, shall witness these tests. After the weld has cooled, all slag shall be removed and the metallurgical bond shall be tested for adherence by the Contractor. A 22-ounce hammer shall be used for adherence testing by striking a blow to the weld. Care shall be taken to avoid hitting the wires. All defective welds shall be removed and replaced in a new location at least 6 inches away from the original weld location.
- E. All exposed surfaces of the copper and steel shall be covered with insulating materials.
 - 1. For dielectrically coated or polyethylene encased pipes, a plastic weld cap with integrated primer shall cover the exothermic weld and surrounding area. All surfaces must be clean, dry, and free of oil, dirt, loose particles, and all other foreign materials prior to application of the weld cap.
 - 2. For mortar coated pipes, epoxy putty covered with mortar shall be applied over the exothermic weld and surrounding area. The mortar shall match the exterior mortar on the pipe.
- F. The Contractor shall inspect the exterior of the pipe to confirm that all coatings removed or damaged as a result of the welding have been repaired. The Contractor shall furnish all

materials, clean surfaces, and repair protective coatings damaged as a result of the welding. Repair of any coating damaged during welding shall be performed in accordance with coating manufacturer's recommendations.

- G. After backfilling pipe, all test lead pairs shall be tested for broken welds using a standard ohmmeter. The resistance shall not exceed 150% of the theoretical wire resistance, as determined from published wire data.

3.08 JOINT BONDS

- A. Joint bonding shall be provided across flexible couplings and all non-welded joints to ensure electrical continuity, except where insulating joints have been installed to provide electrical isolation. Joint bonds type, size, length, and number shall be per Standard Drawings and installed as indicated.
- B. Bonding wires shall allow at least 2 inches of movement in the pipe joint. The wire shall be attached by exothermic welding. At least 2 bond wires shall be provided between all joints.
- C. For ductile iron pipe, the Contractor may, at his or her own expense, provide weld plates that are installed by the pipe manufacturer at the spigot end of the pipe. Provision of the weld plates does not relieve the Contractor from responsibility for repair of damage to the coating or lining as a result of exothermic welding of the pipe. Coating repairs shall be performed in accordance with coating manufacturer's recommendations.

3.09 DIELECTRIC INSULATING FLANGE KITS

- A. Dielectric insulating flange kits shall only be used for above ground applications.
- B. All insulating components of the insulating flanged gasket set shall be cleaned of dirt, grease, oil, and other foreign materials immediately prior to assembly. If moisture, soil, or other foreign matter contacts any portion of these surfaces, disassemble the entire joint and clean with a suitable solvent. Dry the entire joint. Once completely dry, reassemble the joint.
- C. Care shall be taken to prevent any excessive bending or flexing of the gasket. Creased or damaged gaskets shall be rejected and removed from the job site.
- D. Bolt holes in mating flanges shall be properly aligned at the time bolts and insulating sleeves are inserted to prevent damage to the insulation. Follow the manufacturer's recommended bolt tightening sequence. Center the bolt insulating sleeves within the insulation washers so that the insulating sleeve is not compressed and damaged.
- E. After flanged bolts have been tightened, each insulating washer shall be inspected for cracks or other damage. All damaged washers shall be replaced.

- F. When the flange is determined to be properly functioning to the full satisfaction of the District, approval will be granted to proceed with installation. Do not proceed with coating, lining, or backfilling the insulating joint prior to gaining approval to proceed. If the coating or lining is applied prior to gaining approval to proceed, the coating or lining shall be completely removed to the satisfaction of the District at the Contractor's expense. If the insulating joint is backfilled prior to gaining approval from the District, the Contractor shall completely excavate the insulating joint at the Contractor's expense.

3.10 PVC PIPE FOR ISOLATION OF NEW FROM EXISTING PIPE

- A. PVC pipe shall be used for isolation of new DIP to existing CIP underground.
- B. Clean and inspect the pipe ends to insure they are cleaned of dirt, grease, oil, and other foreign materials immediately prior to assembly.
- C. Follow the manufacturer's installation recommendations to determine the correct sized mechanical joint as well as installation procedures.
- D. When the mechanical joint is determined to be properly functioning to the full satisfaction of the District, approval will be granted to proceed with installation. Do not proceed with coating, lining, or backfilling the mechanical joint prior to gaining approval to proceed. If the coating or lining is applied prior to gaining approval to proceed, the coating or lining shall be completely removed to the satisfaction of the District at the Contractor's expense. If the mechanical joint is backfilled prior to gaining approval from the District, the Contractor shall completely excavate the mechanical joint at the Contractor's expense.

3.11 WIRE CONNECTIONS

- A. After installation, all wire connections shall be tested to ensure electrical continuity at the test station locations by the Contractor to ensure that they meet the requirements and intent of the Standard Drawings and Specifications.

3.12 RESTORATION SERVICES

- A. Compaction of backfill for anodes and trenches shall be in conformance with the TRENCH EXCAVATION, BEDDING, AND BACKFILL Section (31 80 00).
- B. RESTORATION OF PAVEMENT: Patch pavement, sidewalks, curbs, and gutters where existing surfaces are removed for construction in conformance with the PAVING, RESTORATION, AND RESURFACING WORK Section (32 10 00) and the CAST-IN-PLACE CONCRETE Section (03 30 00).

3.13 ISOLATION TESTING ON INSULATING JOINTS

- A. Insulating joints shall be installed to effectively isolate DIP from existing metallic structures above ground. The Contractor shall test the performance of these insulating joints.
- B. The Contractor shall test the insulating joint using a Gas Electronics Model No. 601 Insulation Checker or an approved equivalent. If the testing results indicate less than 100% insulation, then the insulating joints shall be repaired and retested at the Contractor's expense.
- C. After installation, testing shall be performed by measurement of native pipe-to-soil potentials at both sides of the insulating joint. If the difference in native pipe-to-soil potentials on both sides of the insulating joint is within ± 100 mV, then additional testing shall be performed, as follows. Temporary CP current shall be circulated on one side of the insulating joint. "On" and "Instant Off" pipe-to-soil potentials shall be measured on the other side of the insulating joint. If the "Instant Off" potential is more negative than the native potential, the insulating joint shall be considered deficient and shall be repaired and retested at the Contractor's expense.

3.14 ISOLATION TESTING ON PVC PIPE MECHANICAL JOINTS

- A. PVC pipe shall be installed to effectively isolate DIP from CIP underground. The Contractor shall test the performance of the PVC pipe before backfilling.
- B. After backfilling, testing shall be performed by measurement of native pipe-to-soil potentials at both sides of the PVC pipe. If the difference in native pipe-to-soil potentials on both sides of the PVC pipe is within ± 100 mV, then additional testing shall be performed, as follows. Temporary CP current shall be circulated on one side of the PVC pipe. "On" and "Instant Off" pipe-to-soil potentials shall be measured on the other side of the PVC pipe. If the "Instant Off" potential is more negative than the native potential, the PVC pipe shall be considered deficient and shall be repaired and retested at the Contractor's expense.

3.15 CONTINUITY TESTING

- A. Continuity testing of joint bonds shall be performed by the District's qualified corrosion technician as defined in this section after backfilling. The electrical continuity test may additionally be performed before backfilling at the Contractor's option.
- B. The pipe shall be tested for electrical continuity. Continuity shall be verified using the linear resistance method. The pipe should be tested in spans that are no less than 250 feet, unless the pipe is shorter than 250 feet, and no more than 1,000 feet. Each test span shall have two test leads connected to the pipe at each end. Existing test stations can be used. A direct current shall be applied through the pipe using two of four test leads. The potential across the test span shall be measured using the other two test leads. The

current applied and voltage drop shall be recorded for a minimum of three different current levels.

- C. The theoretical resistance of the pipe shall be calculated. It shall take into account the pipe wall thickness, material, and joint bonds.
- D. The average measured resistance shall be compared to the theoretical resistance of the pipe and bond wires. If the measured resistance is greater than 125% of the theoretical resistance, then the joint bonds shall be considered deficient and shall be repaired and retested at the Contractor's expense. If the measured resistance is less than 100% of the theoretical resistance, then the test and/or calculated theoretical resistance shall be considered deficient and the test span shall be retested and/or recalculated at the Contractor's expense. If the piping forms a loop which allows current to flow both in and out of the test span, then consideration shall be made for current circulating through both the loop and the test span.

3.16 FINAL SYSTEM CHECKOUT

- A. Upon completion of the installation, the District shall provide testing of the completed system by a Corrosion Technician, and the data shall be reviewed by a Corrosion Engineer to ensure conformance with the Standard Drawings and Specifications, NACE SP0169, and NACE SP0286.
- B. The testing described herein shall be in addition to and not substitution for any required testing of individual items at the manufacturer's plant and during installation.
- C. Testing shall be performed at all test leads of all test stations, junction boxes, and locations of exposed pipe as soon as possible after installation of the CP system.
- D. Testing shall include the following and shall be conducted in accordance with NACE TM0497:
 - 1. Measure and record native pipe-to-soil and anode-to-soil potentials at all test locations.
 - 2. Verify electrical isolation at all insulating joints per NACE SP0286.
 - 3. Confirm electrical continuity of the cathodically protected pipeline in accordance with this Section.
 - 4. Measure and record the "On" and "Instant Off" pipe-to-soil potentials at each location after the pipeline has been given adequate time to polarize.
 - 5. Measure and record the current output of each anode when the CP system is initially turned on and again after it has been given adequate time to polarize.
- E. Test results shall be analyzed to determine compliance with NACE SP0169.

- F. Test results shall be analyzed to determine if stray current interference is present. Stray current interference is defined as a ± 50 mV shift in a pipeline's pipe-to-soil potential that is caused by a foreign current source. Stray current interference shall be tested on the project pipeline and foreign pipelines that have a reasonable chance of being affected by stray currents.
- G. A written report shall be prepared by the Corrosion Engineer, documenting the results of the testing and recommending corrective work, as required to comply with the Contract Documents. Any deficiencies of systems tested shall be repaired and re-tested by the Contractor at no additional cost to the District.

***** END OF SECTION *****

INTENTIONALLY LEFT BLANK

SECTION 31 80 00 - TRENCH EXCAVATION, BEDDING, AND BACKFILL

PART 1 GENERAL

1.01 SCOPE OF WORK

- A. Work included under this section consists of furnishing all necessary labor, materials, tools, equipment, and services in connection with and reasonably incidental to clearing, saw-cutting/grinding pavement, excavating, installing bedding and backfill material, and disposing of excess excavated materials required for the construction of water mains and storm drains. Work required shall also include the furnishing of all materials and equipment necessary for the construction and installation of all temporary shoring, sheeting and bracing and other facilities which may be necessary to perform the excavations and to place and compact the bedding and backfill, and the subsequent removal of such sheeting, bracing and other facilities.
- B. Excavation and backfill shall be in accordance with the Standard Drawings and these Standard Specifications.

PART 2 MATERIALS

2.01 BEDDING MATERIAL

- A. Bedding material shall be "Quarry Fines," produced by Steven Creek Quarry, Cupertino, CA, free of organic material and clay.

2.02 AGGREGATE BASE (CLASS 2)

- A. Aggregate base shall conform to the requirements of Section 26 – Aggregate Bases of Caltrans Standard Specifications. Grading and Quality Characteristics requirements shall meet 3/4" maximum, Class 2 material.

2.03 DRAIN ROCK

- A. Drain rock shall be 3/4" crushed rock.

2.04 PAVEMENT

- A. Pavement shall conform to the requirements in Section 32 10 00 - Paving, Restoration, and Resurfacing Work of these Standard Specifications.

PART 3 EXECUTION

3.01 CONSTRUCTION ACROSS IMPROVED AREAS

- A. Asphalt concrete pavement or driveways removed or damaged in connection with construction shall be rebuilt to these Standard Specifications and have the same quality

as the portion removed. Where pavement or driveways must be removed, they shall be saw-cut prior to excavation.

- B. The Contractor may, when approved by the District, tunnel under driveways. Where existing driveways are removed or damaged by the Contractor, the Contractor shall replace after completion of the installation of the water main or utilities with the same type and quality of material as that which was removed or damaged.

3.02 UNDERGROUND OBSTRUCTIONS

- A. The Contractor shall notify North USA at (811) a minimum of 2 working days before proceeding with the work. Work may not begin until utilities marked.
- B. The Contractor shall determine the exact location of all existing utilities before commencing work, and agrees to be fully responsible for any and all damages by the Contractor's failure to exactly locate and preserve any and all underground utilities.
- C. Excavation and other work under or adjacent to existing water mains, conduits, or structures of any kind, shall be executed in such a manner as not to interfere with the safe operation and use of such installations. Should any damage occur to these facilities during the operations of the Contractor, they shall immediately notify the District and the facility owner(s) or authorities, and shall arrange for the immediate repair of the facilities at his own expense. If any conflicts are encountered during construction, the District shall be notified immediately.

3.03 TRENCH EXCAVATION

- A. Trench Width
 - 1. In all cases, trenches must be of sufficient width to permit the proper jointing of the pipe. However, trenches wider than the maximums specified herein will result in a greater earth load on the pipe than it was designed for; consequently, if the maximum trench widths specified are exceeded by the Contractor without the written permission of the District, the Contractor will be required, at their own expense for both labor and material, to provide a higher class of pipe or to embed the pipe in a concrete cradle as directed by the District.
 - 2. Permissible trench widths are as follows: For all pipes up to and including 18-inches diameter, and in all types of soil, maximum trench width of 24-inches greater than the outside diameter of the pipe will be permitted. This shall be interpreted to permit a maximum of no more than 12-inches on each side of the pipe. This clearance shall be measured from the outside of the barrel of the pipe to the sides of the trench and shall include any sheeting used. The minimum width of un-shored trenches shall be 12-inches plus the outside diameter of the pipe (a minimum of 6-inches on each side of the pipe). Where shoring is required, the Contractor shall allow sufficient width to comply with codes and regulatory safety requirements.

B. "T" Cut

1. A second saw-cut/grind operation is required prior to final paving to achieve the "T" cut section as shown on the standard drawings. Saw-cutting a wider trench during initial trench excavation to achieve a "T" cut section will not be allowed.

C. Shoring

1. The Contractor shall furnish, place and maintain shoring and bracing as may be required to support the sides of excavations for the protection of workers, to facilitate the work; to prevent damage to manholes, structures, and water mains being constructed; to protect adjacent embankments, structures or facilities from damage; and as required by applicable local, State and Federal safety codes.
2. Shoring shall be removed by the Contractor unless field conditions make the removal of sheeting impractical. In such case, the District may permit portions of the sheeting to be cut off to a specified depth and to remain in the trench. Backfill shall be brought to one foot above the top of the pipe before sheeting may be removed.
3. When trenching or excavation over 5-feet in depth, under the Labor Code Section 6705, Contractor shall provide the following:
 - a. Written and detailed plan covering trench and excavation safety procedures that meets CalOSHA requirements under the Construction Safety Orders Sections 1539-1543.
 - b. Submit a written safety plan reviewed and approved by a registered civil or structure engineer for review and approval prior to the start at work.
 - c. Assign a competent person to supervise trenching and excavation operations when work is being performed.
 - d. The Contractor shall obtain and provide the District a copy of a CalOSHA permit for all trench and excavation operations.
4. The Contractor must provide ladders or a safe access within 25-feet of a work area in trenches 4-feet or deeper.

D. Dewatering

1. During water main excavation and backfill operations, the Contractor shall provide temporary drains, diversion ditches, pumps, cofferdams, or other devices as may be necessary to remove surface water or groundwater from the work area. Unless otherwise specifically permitted by the District, water, either of surface or subsurface origin, will not be permitted in the trenches or in new or existing water mains at any time during construction and until backfilling over the top of the pipe has been

completed; nor will the groundwater level in the trench be permitted to rise above an elevation 4-inches below the invert of the pipe. If trench has been flooded prior to placement of bedding material, the bottom of the native trench shall be compacted to the satisfaction of the District. Special care shall be taken during dewatering to ensure compliance with Storm Water Pollution Control Plan.

2. All excavations shall be kept free from water during the time when concrete is being placed and until such time as water will not be detrimental to the finished work. Dewatering trenches, when required, may be accomplished in any manner the Contractor desires, provided the method is acceptable to the District. Any damage resulting from the failure of the chosen method to operate properly shall be the responsibility of the Contractor and shall be repaired in a manner satisfactory to the District, at the Contractor's expense.

E. Structural Clearances

1. Excavation near structures such as catch basins, manholes, and drain inlets shall be sufficient to leave at least 12-inches between the outer surfaces of the structure and the sides of the excavation.

F. Care of Excavated Material

1. All material excavated from trenches and piled adjacent to the trench, or in a roadway or public thoroughfare, must be piled and maintained in such a manner that the toe of the slope of the excavated material is at least a lateral distance equal to the height of the excavation from the edge of the trench. It shall also be piled so that as little inconvenience as possible is caused to public travel. Free access shall be provided to all fire hydrants, water valves, and meters, and all other conduits shall be kept clean to allow free flow of storm water.

G. Open Trench

1. Unless otherwise directed by the District or stated otherwise on the project drawings, no trench shall be excavated more than 200-feet, nor left unfilled past construction working hours or non-working hours.
2. All trenches in roads, whether located on the project roads or in an easement, shall either be backfilled or plated during non-working hours.

H. Excavation Below Grade

1. Except where unsatisfactory native subgrade material exists, no excavation below the bottom of the water main bedding will be permitted. If, for any reason other than unsatisfactory subgrade, excess material is excavated beyond the limits specified for bedding, such excavation below grade shall be replaced beneath the pipe zone with thoroughly compacted subgrade material at the expense of the Contractor.

Unsatisfactory subgrade material shall be removed and replaced as directed by the District.

I. Tree Roots

1. Tree roots two inches or more in diameter at adjacent trees shall not be cut without prior approval of a licensed arborist or the District. Material shall be removed from around root system to avoid damage thereto. Roots shall be protected with burlap wrapping while exposed.

J. Excavation

1. All excavation is unclassified. Work shall consist of performing all excavation operations regardless of the character of subsurface conditions. The Contractor shall make their own evaluation of the type of materials which may be encountered.

K. Excavated Trench Material Disposal

1. Any excess material resulting from trench excavation shall be disposed of offsite by the Contractor own expense in a manner satisfactory to the District. Such excess material may be deposited on private property if so, requested by the property owner and their approval, proper permits shall be obtained for the pertinent local agencies by the property owner and the Contractor. It is recommended that disposed of materials be recycled wherever possible.

L. Trench Plates

1. When backfilling operations of an excavation in the traveled way, whether transverse or longitudinal, cannot be properly completed within a work day, steel plate bridging with a non-skid surface and shoring shall be required to preserve unobstructed traffic flow. Smooth surface plates are not allowed. No more than two (2) trench plates in length will be allowed unless directed by the District.
2. Trench plates shall be A-36 grade steel, non-skid, a minimum of 1-inch thick, and rated for H/20 loading or greater.
3. Tack weld plates together when using multiple plates.
4. The Contractor shall maintain trench plates at all time and respond to and correct shifting trench plates regardless of the time of day. If the Contractor fails to correct sinking backfill material or shifting trench plates in a timely manner, the District reserves the right to correct the problem at the expense of the Contractor.
5. In the event pending inclement weather or other conditions as determined by the District may adversely affect the use of trench plates, they shall be removed, the excavation backfilled, and the surface secured with temporary asphalt.

3.04 TRENCH BACKFILL

A. General

1. No backfilling shall commence until the pipe has been inspected and approved by the District, until concrete in masonry structures such as thrust blocks or encasement has attained a proper strength, and until required fittings are installed and inspected.
2. In backfilling the trench, the Contractor shall take all necessary precautions to prevent damage or shifting of the pipe. Backfilling from the sides of the trench will be permitted after sufficient material has first been carefully placed over the pipe to such a depth as is acceptable to the District.
3. Any backfill which becomes displaced or depressed during construction or during the warranty period, shall be refilled, shaped, and restored to proper grade as frequently as is necessary until the surface is unyielding, at the Contractor's expense.
4. Placement and compaction operation shall be done in 8-inches maximum loose lifts unless otherwise specified by the District. Lifts shall be compacted by the use of mechanical means approved by the District. Compaction equipment or methods that produce horizontal or vertical earth pressures, which may cause excessive displacement or may damage the water main or structure, shall not be used. Ponding or jetting of backfill materials will not be permitted. The trench excavation and adjacent areas shall be backfilled to the grades existing prior to construction.

B. Pipe Embedment Zone Definitions

1. Quarry Fine Bedding shall be defined as the area between the bottom of the pipe and 4-inches below the bottom of the pipe. Pipe Bedding shall consist of leveling the bottom of the trench and furnishing, placing, and compacting quarry fines or other specified material as shown on the project drawings and as specified herein.
2. Quarry Fine Backfill shall be defined as the area between the pipe, the sides of the trench, and 6" above the pipe. Pipe Backfill shall consist of furnishing, placing and compacting quarry fines above the pipe or other specified material as shown on the project drawings and as specified herein.
3. Bedding and backfill material shall be compacted to 90% relative compaction and placed in three lifts. Quarry fines shall be placed in no more than 6-inches lifts or as specified here in. Vibratory plate will not be allowed to compact the pipe backfill.

C. Pipe Embedment Zone Lifts

1. **Lift One** – The first lift shall consist of placing 4-inches of compacted quarry fines to the satisfaction of the District prior to the placement of the pipe. The pipe shall be placed prior to the second lift.

2. **Lift Two** – The second lift shall consist of placing quarry fines around the pipe to the top of the pipe to the satisfaction of the District. The top of the pipe shall be visible prior to the start of compaction for the second lift. Compaction of the backfill around the pipe shall be performed by a pneumatic means such as a “Powder Puff.” No other means of compaction tool shall be allowed without prior approval by the District. Contractor shall use extreme care to avoid hitting the pipe and V-Bio polyethylene wrapping while compacting.
3. **Lift Three** – The third lift shall consist of placing and compacting 6” of quarry fines.

D. Pipe Upper Level Zone

1. “Type A” Trench (Paved Surfaces)
 - a. Defined as backfilling the trench with class 2 aggregate base and compacting it in uniform layers to a relative density of 95%. Temporary pavement of 2-inches minimum thickness shall be placed and maintained to the satisfaction of the District. Compact temporary pavement per Section 32 10 00 - Paving, Restoration, and Resurfacing. The existing paved surface shall then be replaced with a minimum 6-inches thickness of asphalt concrete within 30 days of placing temporary pavement.
2. “Type B” Trench (Graveled Areas / Road Shoulders)
 - a. Defined as backfilling the trench with class 2 aggregate base and compacting it in uniform layers to a relative compaction of 95% to the surface.
3. “Type C” Trench (Unimproved Areas)
 - a. Defined as backfilling with native material removed from the trench and compacting it in uniform layers to a relative density of 90%. Material removed from the trench shall be deposited at a suitable site acquired by the Contractor or on abutting property if requested by the property owner, in writing.
4. “Type D” (Controlled Density Fill)
 - a. Defined as backfilling the trench with controlled density fill as defined in Section 03 30 00 – Cast in Place Concrete Structures to within 6-inches minimum of the surface.

E. Subgrade

1. If the bottom of the trench contains stones or other hard objects which would interfere with the proper placement of bedding material or is unsatisfactory for supporting the pipe, it shall be removed to a depth to be determined by the District and backfilled with bedding material as directed by the District.

2. If water is encountered in the trench or the District inspector determines the subgrade below the pipe embedment zone is unstable the Contractor shall excavate and additional 12-inches and install crushed drain rock. Drain Rock at Bottom shall be defined as placing 3/4-inches crushed drain rock, as defined in Section 31 80 00, wrapped in filter fabric at 12" thickness layer at the bottom of the trench within 4-inches minimum of water main.

F. Compaction Tests

1. The Contractor is responsible achieving the compaction requirements of these specifications. At its discretion the District may perform compaction tests on its own to determine the adequacy of the trench bedding and. Retesting for compaction required by a failing test shall be paid for by the Contractor.

*****END OF SECTION*****

SECTION 32 10 00 - PAVING, RESTORATION, AND RESURFACING WORK

PART 1 GENERAL

1.01 SCOPE OF WORK

- A. Work required under this section consists of furnishing all labor, materials, tools, and equipment incidental to placing new asphalt concrete and/or driveway, road restoration. Paving shall include asphalt concrete surfacing and untreated aggregate base course. Paved and gravel roads includes excavation, filling, spreading, and compaction of the filled areas to conform to the lines, grades, and slopes as shown on the drawings. The work also includes furnishing, installing and maintaining temporary paving and trench plates during construction.

1.02 SUBMITTALS

- A. The Contractor shall submit manufacturer data including catalog cuts, drawings and samples, as appropriate, and letter(s) of compliance as required by Section 01 33 00 - Submittals.

PART 2 MATERIALS

2.01 AGGREGATE BASE/SURFACING

- A. Aggregate shall conform to the requirements of Section 26 - Aggregate Bases, of the latest requirements of Caltrans Standard Specifications. Grading requirements shall be for ¾-inches Class 2 aggregate base.

2.02 ASPHALT CONCRETE

- A. HMA shall be confirm to local agencies Standard and Specification and Section 39 - Asphalt Concrete, of the latest requirements of Caltrans Standard Specifications.

2.03 ASPHALT BINDER

- A. Asphalt binding shall be Grade PG 64-10 per Section 92 - Asphalt Binders, of Caltrans Standard Specifications.

2.04 TACK COAT

- A. Material for covering all (vertical and horizontal) surfaces of old pavement shall be asphalt emulsion Types SS-1 or RS-1 conforming Section 94, Asphalt Emulsions, of the latest requirements of Caltrans Standard Specifications.

2.05 TEMPORARY PAVING

- A. Temporary pavement shall consist of 2-inches of cold mix asphalt over Class 2 aggregate base. The aggregate base shall be equal in depth to the new pavement structural section

or more. The aggregate base shall be brought within 2-inches of the top of the existing pavement and covered with temporary "cold mix" asphalt paving using an SC-250, SC-800 or approved equal. All temporary surfacing shall be installed the same day as backfilling and shall be level with existing pavement.

2.06 SLURRY SEAL

- A. Slurry seal shall be Type II conforming Section 37 - Bituminous Seals, of the latest requirements of Caltrans Standard Specifications.

2.07 STRIPING AND PAVEMENT MARKINGS

- A. Striping and pavement markings shall be thermoplastic per Section 84 – Markings, of latest requirements of Caltrans Standard Specifications.
- B. Striping shall be placed in a continuous operation. The Contractor shall ensure there is enough material to prevent any stopping during placement. No overlapping of striping material or markings is permitted.

PART 3 EXECUTION

3.01 AGGREGATE BASE COURSE

- A. The aggregate base course shall be spread and compacted on the prepared subgrade. The base course material shall be placed in 6-inch max compacted layers and shall be compacted to a minimum relative density of 95%, or for water main work be spread and compacted as described under Section 31 80 00 - Trench Excavation, Bedding, and Backfill.

3.02 AGGREGATE SURFACING COURSE

- A. Gravel road surfacing shall be an aggregate course applied to the base course after compaction in the same manner as specified for the aggregate base course. The surface course shall be placed in one layer. Special care shall be taken to maintain crown or slope for drainage.

3.03 TACK COAT

- A. Apply tack coat to all horizontal and vertical surfaces of existing pavement and to vertical surfaces of curbs, gutters, conforms, and construction joints before placing asphalt concrete on or against them, at the rate of 0.10 gallons per square yard.

3.04 TEMPORARY PAVING

- A. Temporary paving shall be installed over all trenches to a thickness of 2-inches. Temporary paving shall be installed on the same day as acceptable trench compaction is obtained and base material installed and shall be smoothed out using a vibratory plate or

other means approved by the District. No tire/wheel rolling compaction will be allowed. Temporary paving shall be maintained on a daily basis until permanent paving is installed. The final paving operation shall occur within thirty (30) days of placing temporary paving.

3.05 ASPHALT CONCRETE

- A. Asphalt concrete shall be placed in accordance with local agencies Standard and Specifications and Section 39 - Asphalt Concrete, of the latest requirements of Caltrans Standard Specifications for method compaction.
 - 1. Minimum Temperature: The minimum temperature of asphalt concrete delivered to the site shall be at least 250° F, and no more than 370° F.
 - 2. Lift Thickness: Where the total thickness of asphalt concrete to be placed is greater than 3-inches, place in lifts of equal thickness, none of which shall exceed 3-inches.

3.06 SLURRY SEAL

- A. Slurry seal shall be placed in accordance with Section 37 - Bituminous Seals, of the latest Caltrans Standard Specifications. Slurry seal shall fully cure prior of traffic striping/marketing placement.
- B. Temporary traffic delineators (floppies, etc.) shall be removed prior to slurry seal placement.

3.07 TRAFFIC STRIPING

- A. Traffic striping shall be placed, per the City of Belmont, City of San Carlos and/or County of San Mateo requirements, minimum two weeks after placing slurry seal, and shall comply with Section 84 – Markings, of the latest requirements of Caltrans Standard Specifications. All damaged striping and reflectors shall be replaced in kind to duplicate, insofar as possible, pre-construction striping. Cat track shall be approved by the City/County prior to placing any striping and/or marking.

3.08 DAMAGE REPAIR

- A. The Contractor shall be responsible for any damage to existing infrastructures such as curbs, gutters, sidewalks, driveways and any asphalt concrete, liquid asphalt or asphaltic emulsion stains occurring during the course of this Contract. Stains shall be cleaned by sandblasting or any other method satisfactory to the District.

*****END OF SECTION*****

INTENTIONALLY LEFT BLANK

SECTION 33 14 10 - ABANDONMENT OF EXISTING WATER MAIN AND FACILITIES

PART 1 GENERAL

1.01 SCOPE OF WORK

- A. Work included under this section consists of furnishing all necessary labor, materials, tools, equipment, and services necessary to abandon existing water main facilities as specified herein.
- B. Where indicated on the plans, the existing water main and any appurtenances connected to it or part of it, including but not limited to, hydrants, blowoffs, air release valves, service connections and gate valves shall be abandoned.

PART 2 MATERIALS

2.01 AGGREGATE BASE

- A. Aggregate base shall be as specified in Section 31 80 00 - Trench Excavation, Bedding and Backfill".

2.02 PAVEMENT REPLACEMENT

- A. Paving replacement materials and methods shall be as specified in Section 32 10 00 - Paving, Restoration and Resurfacing Work.

PART 3 EXECUTION

3.01 ABANDONMENT OF EXISTING WATER MAIN & FACILITIES

- A. The procedure described herein shall apply, as applicable, to all water mains and appurtenances designated for abandonment.
 - 1. This work shall not be done until the new water main has been successfully tested and is in operation. All work shall be coordinated with the District.
 - 2. After fire hydrant / check valve relocation, the existing hydrant/check valve shall be abandoned by cutting a minimum 18-inches below grade and concrete capping the pipe after the relocated hydrant assemblies have been installed and tested. The Contractor shall deliver the removed hydrants to the District's corporation yard. Stand pipes shall become the property of the Contractor. The Contractor shall also remove any hydrant marker posts for abandoned hydrants.
 - 3. Remove valve boxes (but not extensions of those boxes) and covers on valves located on water mains, fire hydrant runs, and blowoffs to be abandoned. Remove any valve marker posts for abandoned valves. Removed boxes, covers and marker posts shall become the property of the Contractor.

4. Remove existing meters and their respective boxes. The abandonment and removal of the existing meter box shall include removal of the angle meter stop and crimping the copper line within 2-feet of the meter box. Meters are to be delivered to the District's corporation yard. At the discretion of the District, the existing meter boxes, angle meter stops, and copper segments shall also be salvaged and delivered to the District's yard.
5. Services on live water mains shall be abandoned at the water main by installing a Smith-Blair stainless steel clamp as directed by District.
6. The new meter box for the service and/or PRV shall be installed after the abandonment and removal of the existing copper line and angle meter stop.
7. Water mains to be abandoned shall be drained until no water is visible in the pipe. Cut, drain, and plug/cap both ends of all existing water mains and tees with fittings approved by the District.
8. Backfill shall be in accordance with Section 31 80 00 - Trench Excavation, Bedding and Backfill.
9. Restore paved surface as specified in Section 32 10 00 - Paving, Restoration and Resurfacing Work.
10. All abandoned facilities shall be water-tight.
11. Contractor shall use due care when working with asbestos cement pipe and shall comply with all applicable laws and regulations regarding such work. When cutting asbestos cement pipe, Contractor shall ensure that adequate means are used to protect its workers and the environment against asbestos exposure. Asbestos cement pipe shall not be cut with a saw or comparable dust-generating tool, unless adequate encapsulation is provided. Asbestos cement pipe removed by the Contractor's operations shall become his property and be properly bagged and disposed of in an approved manner as required by federal, state, and local regulations.

*****END OF SECTION*****

SECTION 33 14 13 – WATER MAIN

PART 1 GENERAL

1.01 SCOPE OF WORK

- A. Work included under this section consists of furnishing and installing all water main piping, fittings and appurtenances shown on the project drawings and as specified herein.
 - 1. All water mains located west of the Caltrain R/W in the hills, including hydrant runs and tie-ins, shall be constructed entirely of Class 50 zinc coated ductile iron pipe with restrained joint, bonded together per Section 13 47 13 – Cathodic Protection of Ductile Iron Water Main; wrapped in low density V-Bio polyethylene film and marked with No. 8 standard tracer wire.
 - 2. All water mains located east of the Caltrain R/W or anywhere else with known corrosive soils as directed by the District, including hydrant runs and tie-ins, shall be constructed entirely of Polyvinyl Chloride (PVC) pipe; marked with No. 8 standard tracer wire.

1.02 SUBMITTALS

- A. The Contractor shall submit manufacturers' data including catalog cuts, drawings and samples, as appropriate, and letter(s) of compliance as required by Section 01 33 00 - Submittals.

PART 2 MATERIALS

2.01 DUCTILE IRON (DI) PIPE

- A. General
 - 1. Ductile iron pipe shall conform to ANSI A21.50 and A21.51 (AWWA C150 and C151) and shall be Zinc Coated Class 50 pipe with minimum working pressure of 350 psi.
- B. Joints
 - 1. Buried pipe shall all have restrained push-on joints (“Field Lok,”), unless specified otherwise. At fittings and tie-ins, pipe shall have restrained push-on joints, mechanical joints (mega-lugs), or flanged joints as directed by the District. Mechanical joints may be used for closures, subject to meeting thrust restraint requirements. Flanged ends, or plain ends with restrained couplings, shall be used for piping above ground.
 - 2. For mechanical joints, dimensional and material requirements for pipe ends, glands, bolts, nuts and gaskets shall conform to ANSI A21.11 (AWWA C111).

3. For flanged joints, ends of pipe and fittings shall be provided with ductile iron flanges conforming to ANSI A21.10 and A21.15 (AWWA C110 and C115), as applicable. Bolts, nuts, and gaskets for flanged connections shall conform to ANSI B16.1 and as specified in Section 2.08 - Hardware. All flanged connections shall use "Ring Flange-Tyte" gaskets as manufactured by U.S. Pipe capable of withstanding pressures up to 350 psi.

C. Fittings

1. Fittings shall be ductile iron conforming to ANSI A21.53 (AWWA C153) with push-on joint bell design to fit the particular make of the pipe furnished or to fit a pipe-to-fitting adapter unless specified on the plans. Fittings shall have a pressure rating at least equivalent to that of the pipe used.

D. Coating and Lining

1. Buried ductile iron pipe, sleeves and fittings shall be class 50 Zinc coated and asphalt seal-coated, with cement-mortar lined. The lining shall conform to the Standard Specifications of AWWA C104. All above ground fittings and couplings shall be fusion epoxy lined and coated.

E. V-Bio Polyethylene Encasement

1. All buried ductile iron pipe and fittings shall be wrapped in low density V-Bio polyethylene in accordance with AWWA C105, Method A. The tape used to secure the encasement shall be black PVC pipe wrap tape, minimum 10 mil thick. No other tape is allowed.

F. Pipe End Caps During Transport / Storage

1. The interior of all pipe, fittings, and other accessories shall be kept clean and free from organic matter at all times. All pipes shall be delivered to the construction site with end caps on both ends. End cap components must adhere sufficiently to withstand the stresses caused by wind during shipment. Pipes delivered on-site with damage shall be immediately field cleaned to remove all undesirable material along the entire length of the pipe interior. New end caps shall be installed after cleaning.
2. Cut pipe lengths of 5.0-feet or less, fittings, and valves do not require end caps but shall be field cleaned prior to installation.

2.02 PVC PIPE

A. General

1. PVC water mains shall conform to the applicable requirements of latest AWWA C900. Pipes shall be DR 14 pressure class 305 with a DI pipe equivalent outside diameter. Maximum length of each section of pipe between elastomeric rings shall be twenty (20) feet.

B. Joints

1. Buried pipe and pipe fittings shall all have internally restrained push-on joints, unless shown otherwise on the drawings or specified otherwise. At fittings and tie-ins, pipe shall have restrained push-on joints or mechanical joints (mega-lugs). Plain ends with restrained couplings, shall be used for piping above ground.
2. For mechanical joints, dimensional and material requirements for pipe ends, glands, bolts, nuts and gaskets shall conform to latest ANSI A21.11 (AWWA C111).
3. For flange joints with adapters, ends of pipe and fittings shall be provided with flange couplings. Bolts, nuts, and gaskets for flanged connections shall conform to ANSI B16.1 and as specified in Section 2.06 - Hardware. All flanged connections shall use "Ring Flange-Tyte" gaskets as manufactured by U.S. Pipe capable of withstanding pressures up to 350 psi.

C. Fittings

1. Fittings for use on C900 PVC shall be DI conforming to the applicable requirements of latest ANSI A21.53 (AWWA C153). Joints shall be restrained (mega-lug). All bolt-up sets (nuts, bolts and washers) and tie rods for buried valves and fittings shall be stainless steel, ASTM A-276 type 316. Isolated fitting and associate adjacent restraints shall be cathodically protected per Section 13 47 13 – Cathodic Protection of Ductile Iron Water Main.

D. Coating and Lining

1. Buried and/or above ground fittings and sleeves shall be class 50 zinc coated ductile iron and shall have all internal and external ferrous surfaces coated with a fusion bonded epoxy coating of 10 mils nominal thickness. The coating shall conform to latest AWWA C116.

E. Pipe End Caps During Transport / Storage

1. The interior of all pipe, fittings, and other accessories shall be kept clean and free from organic matter at all times. All pipes shall be delivered to the construction site with end-covers on both ends. End-cover components must adhere sufficiently to withstand the stresses caused by wind during shipment. Pipes delivered on-site with damage shall be immediately field cleaned to remove all undesirable material along the entire length of the interior of the pipe. New end covers shall be installed after cleaning.
2. All pipe to be used for water main installation located in the storage area, staging area, or left overnight prior to installation shall have the ends of the pipes covered with plastic (visqueen) and secured with tape to keep the pipe free of debris and dirt.

3. Cut pipe lengths of 5-feet or less, fittings, and valves do not require end-covers but shall be field cleaned prior to installation.

2.03 THRUST RESTRAINTS

A. Push-On Joint Locking Gasket

1. The locking gasket type restrained joint shall consist of stainless steel locking segments molded into the gasket that shall grip the spigot end of the pipe to prevent joint separation. This restrained joint system shall be "Field Lok", manufactured by U.S. Pipe for DI pipe and "Eagle Loc" manufactured by JM Eagle for PVC pipe or equivalent.

B. Mechanical Joint Restraint

1. Mechanical joint fittings shall be EBAA Iron "Megalug". Bolts, nuts, and washers shall be low alloy (Corten).
2. Wedge gaskets shall be used with all mechanical joints. Standard mechanical joint gaskets are not allowed.

2.04 THRUST BLOCKS

- #### **A. Concrete thrust blocks are optional except where required on the drawings. Thrust blocks shall be constructed per the Standard Drawings and Section 03 30 00 – Cast in Place Concrete**

2.05 PIPE CONNECTORS

A. Flexible Couplings

1. Flexible couplings shall be Macro HP Extended Range manufacturer by Romac Industries Inc. Flex coupling must conform to latest AWWA C-219, with Type 316 bolts, nuts, and washers.

B. Flanged Coupling Adapters

1. Flanged coupling adapters shall be EBAA 2100 adapter. Flanges, spools and sleeves shall be high strength ductile iron with Type 316 stainless steel bolts, nuts, and washers.
2. Flange gaskets shall conform to Section 2.01 – Ductile Iron Pipe, Sub-Section B, Joints and Section 2.02 – PVC Pipe, Sub-Section B, Joints.

C. Tapping Sleeves

1. Tapping sleeves shall be JMC Industries 6432, all Type 316 stainless steel bodies, mechanical joint, designed for ductile iron, cast iron and PVC pipe. Bolts, nuts,

washers and associated hardware not part of a mechanical joint assembly shall be plated. No tapping sleeves shall be used for asbestos cement pipe.

2.06 HARDWARE

- A. All bolts, nuts and washers, and restraining tie rods and associated hardware, used with flanged fittings, couplings and appurtenances shall be Type 316 stainless steel for all buried and exposed applications. All bolts shall be furnished with finished hexagonal nuts. The dimensions of all heads and nuts shall be not less than those required for the American Standard regular, and the height shall be sufficient to break the bolt in the body portion when tested. Threads shall be American Standard screw thread, coarse thread series.
- B. Type 316 Steel bolts and nuts hardware shall be used one time per application. Reusing Type 316 Steel hardware is not permitted.
- C. Mechanical joint hardware EBAA shall be high strength, low alloy (Corten).

2.07 TUBING AND FITTINGS

- A. Copper tubing and fittings used for service connections and reconnections shall be Type K, soft, and conform to ASTM 88. Copper tubing shall have blue seamless polyethylene coat, distributed by Mueller Streamline Co.

2.08 MARKER TAPE FOR BURIED PIPING

- A. Marker tape shall be metallic foil bonded to plastic film not less than 2-inches wide. The adhesive shall be colored and be compatible with the foil and film. Film shall be inert polyethylene plastic with thickness not less than 5-mil.
- B. The buried utility line tape shall be identified with an appropriate imprint such as "Caution: Water Main Below" and the identification repeated at approximately 24-inch intervals. Letters shall be 3/4-inch high minimum. The tape shall have a blue imprint.
- C. Marking and warning tape shall be as manufactured by Calpico, Inc., Allen Systems, Inc., Reef Industries, or equivalent.

2.09 TRACER WIRE

- A. Tracer wire shall be No. 8 AWG, standard copper THMW, 600 volt with solid blue insulation.

PART 3 EXECUTION

3.01 TRENCH EXCAVATION, BEDDING AND BACKFILL

- A. Trench excavation, bedding and backfill work shall be performed in accordance with Section 31 80 00 - Trench Excavation, Bedding and Backfill.

3.02 EXISTING UTILITIES AND STRUCTURES

- A. The locations of underground utilities and drainage facilities, where shown on the project drawings, are approximate only. It is the Contractor's responsibility to determine the exact locations of all existing utilities. Where existing culverts, underground facilities, under-ground structures, power, telephone or guy poles or guy wires interfere with construction, the Contractor shall be responsible for coordinating with the appropriate utility companies before removing or relocating any interfering utilities providing that the interfering utilities are shown on the drawings or are visible above grade.

3.03 HANDLING AND DISTRIBUTION OF MATERIALS

- A. Pipe and appurtenances shall be stored in a manner to avoid damage to the materials and to linings and coatings.
- B. The pipe shall be protected to prevent entrance of foreign materials during installation.
- C. All pipe and fittings shall be carefully examined for defects, and no piece shall be installed which is known to be defective. Special care shall be taken to avoid leaving bits of wood, dirt, or foreign particles in the pipe.
- D. All pipe and fittings shall be carefully handled at all times and at no time while loading, unloading, moving, or installing any lined pipe and fittings shall be dropped. All pipe and fittings shall be handled by mechanical means. Wye belt sling shall be used for all coated pipe.

3.04 INSTALLATION OF BURIED PRESSURE PIPING

- A. General
 - 1. Pipe, fittings, and appurtenances shall be installed in accordance with the manufacturer's instructions and in accordance with the latest AWWA C600 for DI pipe and AWWA C605 for PVC pipe.
 - 2. The Contractor shall furnish such parts and pieces as may be necessary to complete the fixtures and apparatus in accordance with best practices of the trade and to the satisfaction of the District.

B. Alignment

1. Piping shall be installed as indicated on the project drawings. Where not detailed, exposed pipe shall be installed in straight horizontal and vertical runs parallel to the axis of the structures.
2. Parallel runs of pipe shall be grouped and kept uniformly parallel. Bends and fittings shall be properly located to maintain uniform spacing and elevation of pipe groups at changes of direction and at branch connections.
3. All pipe shall be carefully placed and supported, and proper lined and grade. Minor adjustments may be necessary to avoid architectural and structural features. Major relocations shall be approved by the District.
4. Project drawings are diagrammatic for piping that is not shown in detail. Size of piping and their location are indicated, but it is not limited to show every offset and fitting nor every structural difficulty that may be encountered during the installation for the work. The pipe alignment shall be varied from indicated on the project's drawings without extra expense to the District where necessary to complete the fixtures and apparatus in accordance with the best practice of the trade and to the satisfaction of the District.
5. The allowable angle of deflection at any joint shall not exceed the amount recommended by the pipe, or coupling, manufacturer for the particular pipe size used.
6. A minimum 3-foot homogeneous length of pipe shall be installed before and after any fitting, valve or other appurtenance. Any sections less than 3-feet will not be permitted.
7. Trench Dams shall be placed on new water main alignments where slopes exceed 10% or as directed by the District and shall be placed every 100-feet in accordance with the Standard Drawings.

C. Valves

1. Valves shall be set with the stems upward and in vertical position, unless indicated otherwise on the drawings. The Contractor shall not operate existing District valves at any time.

D. Joints

1. Pipe shall be assembled and joined in accordance with the manufacturer's published instructions for the type of pipe and joint used. All portions of the joints shall be thoroughly cleaned before the sections of pipe are assembled. The ends of each pipe shall abut against the next pipe section in such a manner that there will be no unevenness of any kind along the bottom half of the interior of the pipe.

2. Where mechanical joints are used with ductile iron pipe, the pipe shall be marked in such a manner that it can be determined after installation that the pipe is properly seated.
- E. Pipe Plugs
1. When pipe laying is not in progress, the open ends of the installed pipe shall be closed with a water tight plug. The plug shall be fitted with means for venting. When practical, the plug shall remain in place until the trench is pumped completely dry. Care must be taken to prevent pipe flotation if the trench fills with water.
- F. Thrust Resistance
1. Restrained joints shall be provided on all joints, at all bends, vertical bends, tee branches, and dead ends for ductile iron pipe.
 2. Concrete thrust blocks shall be cast between undisturbed ground and the fitting to be anchored as shown on Standard Drawings. Blocks shall be poured so that the pipe and the fitting will be accessible for repairs.
 3. Restraints must be used throughout the full length of any DI and/or PVC pipe installed in a casing to the nearest fitting on each side of the casing (i.e., the casing installation does not provide effective thrust resistance).
 4. Where restraints are used, the manufacturer's written instruction for installation shall be followed.
- G. Encasement for Ductile Iron Pipe and Fittings
1. Encasement for ductile iron pipe and fittings shall be in accordance with ANSI/AWWA C105/A21.5-05 Method A.
 2. Ductile iron pipe and fittings shall be encased with the encasement prior to placement in the trench. Encasement shall be cut approximately 2-feet. longer than the length of the pipe. It shall be slipped around the pipe, centering it to provide a 1-foot. overlap on each adjacent pipe section and bunching it in an accordion-fashion lengthwise until it clears the pipe end.
 3. After assembling the pipe joint, the overlap of the encasement from the proceeding shall be pulled over to the new length of pipe and secured in place. Then, the overlap end of the encasement from the new pipe section shall be slip over to the preceding pipe and secured in place. Installation of the next section of pipe shall be in the same manner.
 4. The excess encasement along the length of the pipe shall be folded back and secured at quarter points. The slack of the pipe shall be snug but not tight.

5. Encasement cuts, tears, punctures, or other damage to the encasement shall be repaired with adhesive tape or with a short length of encasement sheet wrapped around the damaged area.
6. Bends, reducers, offsets, and other pipe shaped appurtenances shall be covered with encasement in the same manner as the pipe.

H. Marker Tape Installation

1. Tape shall be installed in the backfill centered over the water main, as shown on the Standard Drawings.

I. Installation of Tracer Wire

Standard tracer wire No. 8 shall be taped to PVC and DI pipe every six feet (6') along top center axis.

J. Cathodic Protection

1. Cathodic protection for buried ductile iron pipe, fitting appurtenances shall be used per Section 13 47 13 – Cathodic Protection of Ductile Iron Water Main.

K. Disinfection

1. Water main disinfection shall be in accordance with the AWWA C651 and shall be supervised by the District. The Contractor shall not disinfect the water main until they have coordinated with the District.
2. The Contractor shall submit disinfection methodology and material information for District review and approval prior to disinfection, per Section 01 33 00 – Submittals.
3. Filling and contact time shall be per AWWA C651. When installation is completed, the water main shall be filled with water at a rate to ensure the water within the water main will flow at a velocity no greater than 1 ft/sec (0.3 m/sec). Precautions shall be taken to ensure air pockets are eliminated. This water shall remain in the pipe for at least twenty-four (24) hours. If the water temperature is less than 41° F (5° C), the water shall remain in the water main for at least forty-eight (48) hours.

L. Bacteriological Test

1. Standard conditions:
 - a. After the final flushing and before the new water main is connected to the distribution system, two consecutive sets of acceptable samples, taken at least 24 hours apart, shall be collected from the new water main. At least one set of samples shall be collected from every 1,200 ft of the new water main, plus one set from the end of the line and at least one set from each branch. Samples shall be tested for bacteriological (chemical and physical) quality in accordance with the

most recent *Standard Methods for the Examination of Water and Wastewater* (AWWA, 6666 W. Quincy Avenue, Denver, CO 80232, (303) 794-7711, APHA, 800 I Street, NW, Washington, DC 20001, (202) 777-2742, or WEF, 601 Wythe Street, Alexandria, VA 22314-1994, (800) 666-0203). Water shall show absence of coliform organisms, and the chlorine residual shall be within 0.4 mg/l of the chlorine residual of the water being used to fill the new water main and HPC count shall be less than 500 colony-forming units (cfu) per ml. If the first sample test fails the District will require additional tests to find the turbidity, pH, and a standard heterotrophic plate count (HPC) level.

2. Special conditions:

- a. If excessive quantities of dirt, debris, or trench water have entered the new water main, bacteriological samples shall be taken at intervals of approximately 200 ft or as directed by the District. Additional samples shall be taken of water that stood in the new water main for at least 16 hours after final flushing has been completed.

3. Sampling Procedure:

Samples for bacteriological analysis shall be collected in sterile bottles treated with sodium thiosulfate, as required by *Standard Methods for the Examination of Water and Wastewater*. No hose or fire hydrant shall be used in the collection of samples without prior approval from the District. If no other sampling ports are available, a well-flushed fire hydrant with a hose bib may be used with the understanding they do not represent optimum sampling conditions. A corporation-stop with a copper standpipe assembly or a temporary combination blow-off assembly may be used for sampling the new water main. The sampling pipe must be dedicated and clean, disinfected and flushed prior to sampling. There should be no water in the trench up to the connection for sampling. All samples shall be delivered to the lab within eight (8) hours after collection.

4. Sample Results.

- a. If sample results from the lab indicate a measured coliform organism and/or HPC greater than 500 colony-forming units (cfu) per mL, flushing should be resumed and another coliform and HPC set of samples should be taken until no coliform are present and the HPC is less than 500 cfu/mL.

5. Record of Compliance.

- a. The record of compliance shall be the bacteriological test results certifying the water sampled from the new water main is free of coliform bacteria contamination.

6. Re-disinfection

- a. If the initial disinfection fails to produce satisfactory bacteriological results, the new water main shall be re-flushed, re-chlorinated, and re-sampled at the expense of the Contractor. If check samples also fail to produce acceptable results, the water main shall be re-chlorinated until satisfactory results are obtained – that being two (2) consecutive sets of acceptable samples taken twenty-four (24) hours apart.

M. Tie-ins

1. Final connection to existing water main shall be in accordance with latest ANSI/AWWA C651.
2. Water main and all appurtenances must be completely installed, flushed, disinfected, and satisfactory bacteriological sample results received prior to permanent connections being made to the active distribution system. The new pipe, fitting, and valve(s) required for the connection shall be swabbed with a minimum 1-5% solution of chlorine just prior to installation.
3. District shall be notified at least two (2) working days in advance of any scheduled tie-ins.
4. No tie-ins, or shutdowns, will be allowed on Fridays or the day preceding a holiday.
5. No shutdown shall exceed six (6) hours in duration.
6. The Contractor shall designate a person to contact should trench maintenance or other problems arise during non-working hours or days. The District shall be given that person's name and phone number.

3.05 INSTALLATION OF ABOVE GROUND EXPOSED PRESSURE PIPING

A. General

1. Pipe, fittings, and appurtenances shall be installed in accordance with the manufacturer's specifications and related section 3.04 of these Standard Specifications or as directed by the District.

B. Exposed Pipe

1. Extreme care shall be taken to ensure watertight joints. All pipe shall be free of all dirt and grease to secure a tight bond with concrete or waterproof material.
2. Metallic pipe shall be coated with fusion epoxy bound.

3.06 CASING

A. Fittings

1. Field locks shall not be used on the first fittings on the pipe coming out of the steel casing.

3.07 PRESSURE PIPE ACCEPTANCE TESTS

- A. All newly installed sections of pressure piping including but not limited to service connections shall be pressure and leak tested as described herein. Testing procedures shall be in accordance with the requirements of latest AWWA C600 for ductile iron pipe and latest AWWA C605 for PVC pipe as modified herein. The tests may be run simultaneously at the Contractor's option.
- B. For buried pressure water mains, tests shall be made on sections not to exceed 2500 feet in length. All necessary equipment, material and labor required shall be furnished by the Contractor. The District will monitor all testing operations. Testing against new valves is permitted at the Contractor's risk. No testing is permitted against existing system valves.
- C. Tests can only occur after the trench has been backfilled.
- D. The test pressure shall not be less than 1.25 times the stated working pressure of the water main measured at the highest elevation along the test section and not less than 1.5 times the stated working pressure at the lowest elevation of the test section. The test pressure in the main shall be maintained for a period of two (2) hours. The test pressure shall not vary by more than ± 5 psi for the duration of the test. The water required to maintain the test pressure within the allowance pressure loss shall be measured by means of a graduated barrel, drum or similar device at the pump suction.
- E. No leakage shall be permitted for exposed piping.
- F. Allowable leakage for buried pipe shall be as follows:

$$L = \left(\frac{SD\sqrt{P}}{148,000} \right) \times 2$$

L = testing allowance (makeup water) (gph for 2 hours)

S = length of pipe tested (ft)

D = nominal diameter of the pipe (in.)

P = average test pressure during the hydrostatic test (psi [gauge])

Allowable Leakage for DI/PVC (gal/1000 ft./2 hrs.)

Test Pressure	6-inch	8-Inch	10-Inch	12-Inch
150 psi	0.99	1.32	1.66	1.99
175 psi	1.07	1.43	1.79	2.15
200 psi	1.15	1.53	1.91	2.29

- G. Should testing disclose leakage in excess of that required in the preceding table, defective joints or pipe shall be located, repaired and retested until satisfactory at no additional cost to the District.

3.08 FLUSHING AND DECHLORINATION

- A. Flushing and dechlorination of the water main shall be supervised by the District. The Contractor shall not flush or dechlorinate the water main until they have coordinated with the District.
- B. A Flushing/Dechlorination Plan and Water Pollution Control Plan must be approved by the District prior to any flushing or draining of the new/abandoned water main and appurtenances.
- C. Prior to any flushing, the Contractor shall install and secure BMP's at storm drain inlets/catch basins. Repair, replace, and secure BMP's if needed before proceeding with the flushing operation.
- D. A flushing sock shall be installed to treat chlorinated water with dechlorination tablets.
- E. All foreign matter shall be flushed from the water main prior to disinfection. Hoses, temporary piping, or other devices shall be provided to dispose of flushing water without damage to adjacent properties. An approved backflow device shall be used when flushing and filling newly-constructed mains.
- F. Following chlorination, all treated water shall be flushed from the mains until the replacement water shall, upon testing, both chemically and bacteriologically, be proven equal to the water quality at the point of supply. Chlorination shall be repeated, if necessary, by the Contractor if the replacement water does not prove equal to the water quality at the point of supply. Actual testing of the bacteriological water sample for chlorine residual shall be conducted by District personnel.
- G. A disposal plan of chlorine-water mixture shall be submitted to the District 5 working days in advanced for review. Upon approval of the disposal plan by the District, the Contractor may proceed with disposal of the chlorine-water mixture per Section 01 57 23 - Storm Water Pollution Control Plan\Erosion Control.
- H. The Contractor shall not allow the treated water to discharge onto open surface or waterway without adequate dechlorination or other satisfactory method of reducing the chlorine concentration to zero.

3.09 CUTTING AND DISPOSAL OF EXISTING ASBESTOS CEMENT PIPE

- A. Contractor shall use due care when working with asbestos cement pipe and shall comply with applicable laws and regulations regarding such work.
- B. Snap cutters shall be used to cut asbestos cement pipe. When cutting asbestos cement pipe, Contractor shall ensure that adequate means are used to protect its workers and the environment against asbestos exposure.
- C. Asbestos cement pipe shall not be cut with a saw or comparable dust-generating tool.
- D. Asbestos cement pipe removed by the Contractor's operations shall become their property and be properly bagged and disposed of in an approved manner as required by federal, state and local regulations.

*****END OF SECTION*****

SECTION 33 14 20 - VALVES AND APPURTENANCES

PART 1 GENERAL

1.01 SCOPE OF WORK

- A. Work included under this section consists of furnishing and installing valves and appurtenances as shown on the Standard Drawings and as specified herein.

1.02 SUBMITTALS

- A. The Contractor shall submit manufacturer's data including catalog cuts, drawings and letter(s) of compliance as required by Section 01 33 00 - Submittals.

PART 2 MATERIALS

2.01 GENERAL

- A. Brass goods furnished under this section shall be new and unused. All fittings shall conform to latest ANSI/AWWA Standard C800.
- B. All brass components in contact with potable water must be made from either CDA/UNS Brass Alloys C89520 or C89833 with a maximum lead content of .25% by weight. Brass alloys not listed in ANSI/AWWA C800 Paragraph 4.1.2 are not approved. Brass saddles shall be made from CDA/UNS C83600.
- C. All fittings shall be stamped or embossed with a mark or name indicating that the product is manufactured from the low-lead alloy as specified above.

2.02 GATE VALVES

- A. Gate valves shall be Mueller A-2362 and have either flanged or mechanical joint ends as shown on the Standard Drawings. The valve shall be resilient seat and fully comply with the latest AWWA C509, and also be UL listed and FM approved. The valves shall be tested and certified to ANSI/NSF 61.
- B. The valve shall have a 350 psig working pressure. Each valve shall be factory seat tested to 350 psig and shell tested to 500 psig. Buried valves shall be NRS (non-rising stem), equipped with a 2-inch square bronze operating nut (open left), and have an arrow cast on the operating nut opening direction. The bolt that attaches the operating nut to the stem shall be recessed into the operating nut so as not to interfere with valve wrench operation.
- C. All main line valves shall be 8-inches or larger in diameter and shall have flanged or mechanical joint ends (on PVC or DI pipes) or push-on with FieldLok (on DI pipes). Main line valves smaller than 8-inches shall require prior written approval by the District. Flanges shall be dimensioned, faced and drilled in accordance with ANSI B16.1 for Class

125 unless stated otherwise on the drawings or the specifications. All necessary caulking materials, gaskets, bolts, and nuts shall be provided. All valves shall be protected from damage before installation and until completion of work.

- D. All buried valves shall be furnished with Type 316 stainless steel valve stem packing and bonnet bolts. All external flanged bolts, nuts and washers for all valves shall be Type 316 stainless steel. Corten T-bolts are allowed on mechanical joints.
- E. The valve stem shall be made standard bronze material. The stem shall have at least one "anti-friction" thrust washer above and below the stem collar to reduce operating torque. The design of the NRS valve stem shall be such that if excessive input torque is applied, stem failure shall occur above the stuffing box at such a point as to enable the operation of the valve with a pipe wrench or other readily available tool. Valves with two-piece stem collars are unacceptable.
- F. The NRS valves shall have a stuffing box (with dirt seal) that is o-ring sealed. Two o-rings shall be placed above and one o-ring below the stem thrust collar. The thrust collar shall be factory lubricated. The thrust collar and its lubrication shall be isolated by the o-rings from the waterway and from outside contamination providing permanent lubrication for long term ease of operation. Valves without a stuffing box are unacceptable. Valves without at least three stem o-rings are also unacceptable.
- G. The valve disc and guide lugs must be fully (100%) encapsulated in EPDM. The peel strength shall not be less than 75 lbs/in. Guide caps of an Acetal bearing material shall be placed over solid guide lugs to prevent abrasion and to reduce the operating torque. Guide lugs placed over bare metal are not acceptable.
- H. The valves shall have all internal and external ferrous surfaces coated with a fusion bonded thermosetting powder epoxy coating of 10 mils nominal thickness. The coating shall conform to AWWA C550.
- I. The valves shall be warranted by the manufacturer against defects in materials or workmanship for a period of ten (10) years from the date of manufacture. The manufacturing facility for the valves must have current ISO certification.

2.03 GATE VALVE EXTENSION

- A. Gate valve extension is required on any valve nuts installed more than 3-feet below finished grade or as directed by the District. Gate valve extension shall be ProSelect, PS4000 series with centering plate.
- B. The Contractor shall have various sizes of valve extension on hand to accommodate varying field conditions. The extension length selected shall be such that the top of extension nut is installed at least 18-inches but no more than 20-inches below the finished grade.

2.04 HYDRANTS

- A. Hydrants shall be Clow 860 (wet barrel) with Muller J6000 break-off check valve assembly. The break-off check valve assembly shall have Type 316 stainless steel bolts and nuts and installed per manufacturer recommendation.
- B. Hydrants shall have two 2-1/2-inch outlets and one 4-1/2-inch pumper outlet. Hydrants shall have a 6-inches flanged inlet per the Standard Drawings.
- C. The Contractor shall have various sizes of hydrant buries on hand to accommodate varying field conditions. The bury length selected shall be such that the bottom of the break-off flange is at least 1-inch but no more than 4-inches above the finished grade.
- D. Hydrants and all metal above the concrete collar shall be factory painted “white” using Ellis priming V17500 and semi-gloss high solids polyurethane P29 direct to metal paint as manufactured by Ellis. Contractor shall submit a color sample for review.
- E. All bolts, nuts and washers, and restraining tie rods and associated hardware, used with flanged fittings, couplings and appurtenances shall be Type 316 stainless steel.

2.05 COMBINATION AIR VALVES

- A. Combination air valves shall be capable of positive action in releasing air accumulations in water mains under full line operating pressure and shall vent or exhaust air during filling and draining operations. Valves shall be of the size and pressure rating indicated on the project drawings or if not so indicated shall be 1-inch with a 5/64-inch orifice and simple type lever, rated for operation at 250 psi minimum for water main 8-inch and smaller, and 2-inch with a 3/32-inch orifice and simple type lever, rated for operation at 250 psi minimum for water main 10-inches and larger. Combination air valve shall be A.R.I. D-040.

2.06 METER VALVES AND COUPLINGS

- A. All service fittings shall be certified as suitable for contact with drinking water by an ANSI accredited organization in accordance with ANSI/NSF Standard 61, Drinking Water Systems Components – Health Effects.
- B. Compression ball angle meter valves shall be angle pattern, with lock wing. Compression ball angle meter valves for 5/8-inch and 1-inch meter connections shall be Mueller B-24258N. Compression ball angle meter valves for 1-1/2-inch and 2-inches meter connections shall be Mueller B-24276N.
- C. When a 5/8-inch meter is being installed, Ford A-13-NL and/or Ford A-14-NL meter adapters shall be installed on the inlet and/or outlet sides of the meter.
- D. Insulated meter couplings shall be Mueller H-10871N.
- E. Residential ball valve shall be Red White 5044AB

- F. When the customer's water service is PVC, Mueller V-15442 (female) or V-15440 (male) Pack Joint connection shall be used.

2.07 CORPORATION STOPS

- A. Corporation stops shall be Mueller N-35008N (insulated), with inlet AWWA taper thread and outlet compression connection for 5/8-inch and 1-inch service.
- B. Corporation stops shall be Mueller N-35008N on a 1-1/2-inch to 2-inches service connection.
- C. Corporation stops shall be Mueller B-30045N on a 1-inch and 2-inches combination air valve.

2.08 SERVICE SADDLES

- A. Service saddles shall be bronze with neoprene gaskets with double bronze straps, Mueller No. BR2B "CC" for DI pipe and Mueller No. BR2S "CC" for PVC pipe, sized for the exact outside diameters of the pipes on which they will be installed.

2.09 BLOWOFF ASSEMBLY

- A. Blowoff assembly shall have a 2-inches vertical FIP inlet and 2-inches NIP for mains 6-inches and smaller, or 4-inches vertical FIP inlet and 4-inch MIP outlet for mains 8-inches and larger. Blowoff assembly shall be operated by turning a top-mounted square operating nut. All internal working parts and the inlet and outlet fittings shall be manufactured from low-lead brass. All working parts shall be serviceable from above without removing the valve box. Blowoff assembly shall be Truflo Model No. TF550 (2-inches) or Model No. 7600 (4-inches) as manufactured by the Kupferle Foundry Co., St. Louis, MO.

2.10 BACKFLOW PREVENTER

- A. Backflow preventer shall operate on the reduced pressure principle and shall consist of two spring-loaded check valves and a spring-loaded, diaphragm actuated, differential pressure relief valve located between the two check valves, in accordance with the Standard Drawings. The backflow preventer assembly shall meet all applicable requirements of latest AWWA C511 and shall be included on the most current "List of Approved Backflow Prevention Assemblies" of the San Mateo County Health System.
- B. Backflow preventer shall be provided on all service connections to properties having a supplemental source of water, wells, fire sprinkler system, irrigation system that has an automatic chemical feeding control, pumps, multi-story buildings or any other instances that has a potential to contaminate potable water supply or as directed by the District.

2.11 VALVE AND METER BOXES

- A. Valve boxes shall be concrete traffic-type boxes with cast iron traffic covers. Covers shall be marked "WATER". Concrete extension pieces shall be provided with each box as required. For deep bury conditions for valve boxes, 8-inches SDR 35 PVC pipe extensions shall be. Diameter shall be 10-3/8-inches minimum with 9-inches throat diameter. Valve boxes shall be Christy "Machined Faced" Model G05T with G505CT cover.
- B. For 8/5-inch inch or 1-inch meters, meter boxes shall be Christy Model B16 concrete box with B16P reinforced concrete lid. For 1-1/2-inch or 2-inches meters, meter box shall be Christy Model FL30T Fiberlyte box with a FL30P Fiberlyte lid. For 1-1/2-inch or 2-inches meters with bypass, meter box shall be Christy Model N48 concrete box with a N48-62D-P Steel lid. Meter Lids shall be marked "WATER" and have one recessed probe hole, made for Sensus FlexNet radio readers. Traffic rated box and cover shall be provided in traffic area and where directed by the District.
- C. Water service PRV boxes shall be concrete reinforced concrete cover. For 1-inch PRV, boxes shall be a Christy BX09B with a BX09D reinforced concrete lid or as noted on the plans. For 2-inch PRV, boxes shall be a Christy B16B with a B16G reinforced concrete lid or as noted on the plans.
- D. Boxes for the 2-inches blowoff shall be G05T valve box with G505CT cover and for 4-inches blowoff assembly shall be Christy Model B1324 (H/20 loading) with B1324-61JH steel checker plate cover.
- E. Boxes installed in driveways and other paved areas shall be traffic rated box and have traffic rated covers.

2.12 PRESSURE REDUCING VALVE

- A. The pressure reducing valve shall be installed according to the project plans. Contractor shall submit for review and approval shop drawings for the pressure reducing valve and vault assembly.
- B. Pressure reducing valve shall be a Cla Val, models approved by the District, and installed per the plans and manufacturer's recommendation.
- C. Pipe supports shall be installed per detail drawings.
- D. Pressure gages shall be liquid filled and accommodated pressure shown on plans.
- E. After the pressure reducing valve and vault has been installed, the vault shall be cleaned from all construction debris.
- F. All bolts, nuts and washers, and restraining tie rods and associated hardware, used with flanged fittings, couplings and appurtenances shall be Type 316 stainless steel.
- G. Contractor shall coordinate with District for a temporary shutdown.

PART 3 EXECUTION

3.01 VALVES INSTALLATION

- A. Valves shall be carefully installed in their respective positions, accessible for operation and repair, and free from all distortion and strain, with joints made as specified, and shall be left in satisfactory operating condition. Buried gate valves, and valve boxes, shall be installed in accordance with the Standard Drawings.
- B. Before installation, all valves and appurtenances shall be thoroughly cleaned of all foreign material, and shall be inspected for proper operation, both opening and closing and to verify that the valves seat properly. Valves shall be installed so that the stems are vertical.
- C. A marker post shall be installed adjacent to each gate valve, combination air valve, and blow-off assembly. The location for each post will be selected by the District based on field conditions.
- D. Valves located within 10-feet of a fitting shall be moved directly to the fitting and connected via a flanged joint or as directed by the District.

3.02 VALVE AND METER BOX INSTALLATION

- A. Valve boxes shall be centered and set plumb over the wrench nuts of the valves and shall not transmit shock or stress to the valves. Valve box covers shall be set flush with the surface of the finished grade or as directed by the District. Backfill shall be placed around the valve boxes and thoroughly compacted to a 95% relative in such a manner that will not damage or displace the valve box from proper alignment or grade. Misaligned valve boxes shall be re-excavated, replumbed, and backfilled at the Contractor's expense. No riser or extension rings are allowed. 8-inches SDR 35 PVC pipe extensions shall overlap the gate valve box a minimum of 6-inches.
- B. Water meter boxes shall be the last item set after the existing angle meter and copper piping is removed. Meter boxes shall be set parallel to the service line following the contour of existing ground. After the box is set and aligned with the meter, contractor may use native material, aggregate base, or fines to backfill around the box as directed by the District and as applicable. Soil within a 12-inches perimeter of the box shall be compacted to a relative density of 90% using a pneumatic device such as a "Powder Puff" or other mechanical means approved by the District.
- C. Finished elevation of the box shall be 1-inch above finished grade when located in non-traffic areas and flush with pavement when located in traffic areas and pathways.
- D. Contractor shall set the box "knockout" in-line with service, and a 1-inch clearance between the box and service line. The box shall not sit on top of the service line.
- E. After the box has been set and compacted, any debris and dirt inside the box shall be removed and disposed of to the District's satisfaction.

- F. Contractor shall bear the responsibility of private property structures such as mail boxes, retaining walls, landscaping, etc., during construction.

3.03 INSTALLATION OF SERVICES

- A. All services shall be 1-inch or 2-inches in size and installed in conformance with the Standard Drawings.
- B. Applications for services larger than 1-inch require hydraulic calculation justification and prior approval from the District. Services larger than 2-inches also require submitting a shop drawing.
- C. Contractor is responsible to determine ahead of time the necessary material to connect the service with the resident's service line. Contractor shall coordinate with the District to determine the configuration and location of the service.
- D. Direct tapping of ductile iron pipe shall be done using the "preferred method" described in AWWA C600, Section 4.8 to preserve the integrity of the existing encasement. This method requires the application of two or three layers of polyethylene adhesive tape completely around the pipe to cover the area where the tapping machine and chain will be mounted. The corporation stop shall then be installed directly through the polyethylene tape and encasement. If damaged, the encasement and/or tape shall be repaired with tape.
- E. Direct tapping of PVC pipe shall be done using the "preferred method" described in AWWA C605, Section 6.4.
- F. Service relocations shall be done by "freezing" the service line with CO₂ or other approved method by the District to temporary discontinue the supply of water while relocating the service. Crimping will not be allowed to temporary block the supply of water.

3.04 INSTALLATION OF FIRE HYDRANTS

- A. Fire hydrants shall be plumbed vertical and installed in accordance with the Standard Drawings. Fire hydrants shall be set so the bury line mark on the break-off is level with finish grade.
- B. All hydrants shall be flushed and tested after installation to ensure a sound setting and smooth operation. All valves shall close drip tight.
- C. All hydrants shall be flushed and tested after installation to ensure a sound setting and smooth operation. All valves shall close drip tight
- D. Contractor shall install a two-way, reflective pavement marker at each fire hydrant location as directed by the local agencies. If the marker does not adhere to existing ground, place it on top the gate valve cover located directly off the main. The markers shall be furnished and installed in accordance with applicable paragraphs of Section 84 –

Markings, of the latest requirements of Caltrans Standard Specifications. Fire hydrant valve lid and rim shall be painted direct to metal white.

3.05 BLOW-OFF ASSEMBLY INSTALLATION

- A. Blow-off assembly shall be installed in accordance with the Standard Drawings.

3.06 COMBINATION AIR VALVES INSTALLATION

- A. Combination air valves shall be plumbed vertical and installed in accordance with the Standard Drawings.

3.07 INSTALLATION OF BACKFLOW PREVENTERS

- A. Backflow preventer shall be installed horizontal and level, with the minimum clearances for obstructions as shown on the Standard Drawings. Vertical installations are allowed but require District approval prior to design and installation. A ball valve shall be installed on both sides of the backflow preventer assembly. Mueller's H-15531N compression x MIPT 90's shall be used at both ends of the assembly to allow removal of the unit in the event of a malfunction. Backflow preventers assembly shall be tested and certified by a San Mateo County's Certified Tester prior to being put in service. Valves failing the test shall be replaced, and retested.
- B. Contractor is responsible to determine ahead of time the necessary material to connect the backflow preventer with the resident's service line. Contractor shall coordinate with the District to determine the configuration and location of the backflow preventer.

*****END OF SECTION*****

STANDARD DRAWINGS

DESCRIPTION	STANDARD DRAWING NO.
Trench Section – Type A Paved Surfaces	MP-01
Trench Section – Type B Graveled Areas/Road Shoulders	MP-02
Trench Section – Type C Unimproved Area	MP-03
Trench Section – Type D Controlled Density Fill	MP-04
Gate Valve Assembly	MP-05
Water Valve/Water Main Marker Post	MP-06
Thrust Block Details	MP-07
Fire Hydrant Assembly (Clow 860)	MP-08
Fire Hydrant Retaining Wall	MP-09
Hydrant Clearances	MP-10
Bollard	MP-11
5/8" or 1" Service Connection	MP-12
1 1/2" or 2" Residential Service Connection	MP-13
1 1/2" or 2" Service Connection with Bypass	MP-14
Service Meter Clearances	MP-15
1" or 2" Combination Air Valve	MP-16
Blow-off Assembly	MP-17
Sampling Station	MP-18
Minimum Pipe Separation Requirements	MP-19
Trench Dam	MP-20
Fire Service Connection Requirements (4" or Greater)	MP-21
Reduced Pressure Backflow Preventer Assembly (Residential)	MP-22
Flush Mounted Test Station Box	MP-23
Wire Identifier	MP-24
Exothermic Weld	MP-25
Pipe Joint Bonding	MP-26
Above Ground Insulating Flange Assembly	MP-27
Double Encasement	MP-28

DESCRIPTION	STANDARD DRAWING NO.
Potential Test Station (PTS)	MP-29
Insulating Joint Test Station (IJTS) CIP Tie-in	MP-30
Anod Test Station (ATS)	MP-31
Anode Test Station (ATS), DI Fitting or Valve with PVC Pipe	MP-32

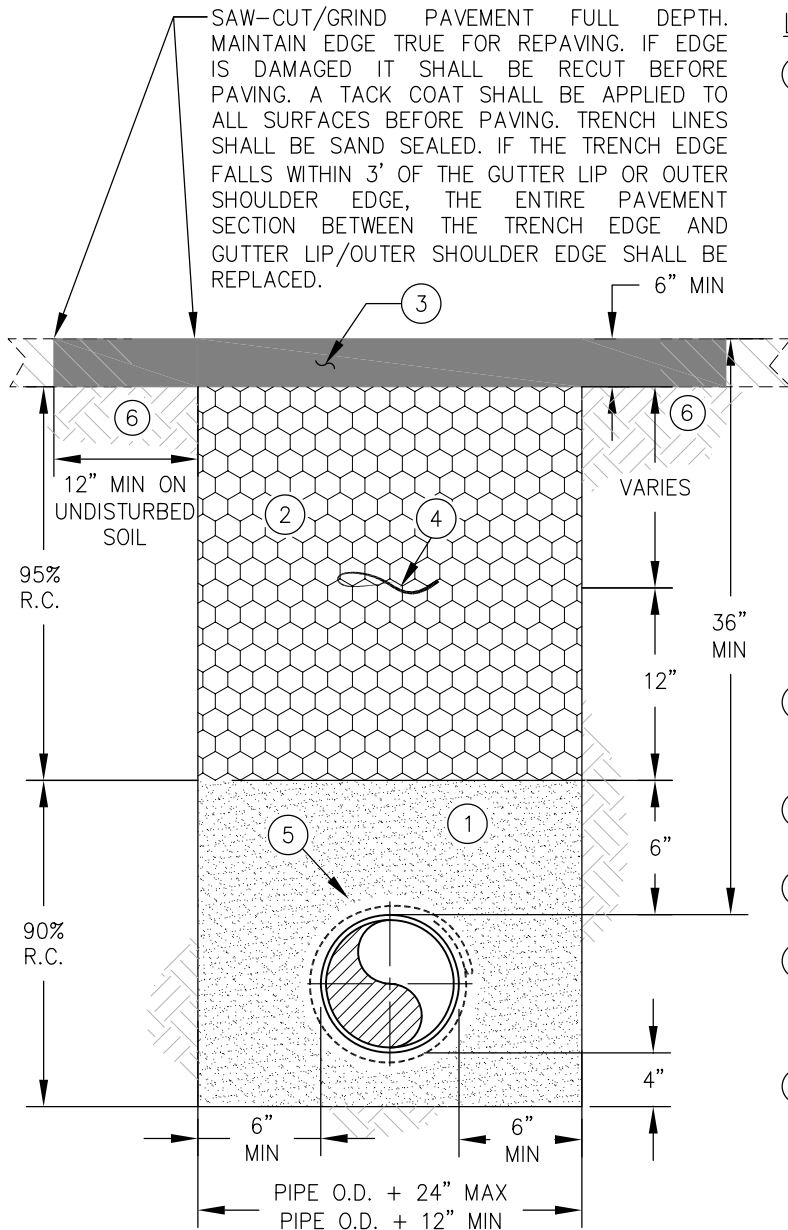

LEGEND

① EMBEDMENT ZONE (QUARRY FINES) SHALL BE PLACED IN THREE LIFTS:

LIFT ONE – SHALL CONSIST OF PLACING AND COMPACTING 4" OF MATERIAL PRIOR TO THE PLACEMENT OF THE PIPE. THE PIPE SHALL THEN BE PLACED PRIOR LIFT TWO.

LIFT TWO – SHALL CONSIST OF PLACING MATERIAL AROUND THE PIPE TO THE TOP OF THE PIPE. THE TOP OF THE PIPE SHALL BE VISIBLE PRIOR COMPACTION OF THE SECOND LIFT. COMPACTION AROUND THE PIPE SHALL BE PERFORMED BY PNEUMATIC MEANS SUCH AS A "POWDER PUFF." NO OTHER MEANS OF COMPACTION SHALL BE ALLOWED WITHOUT PRIOR APPROVAL BY THE DISTRICT. CONTRACTOR SHALL USE EXTREME CARE TO AVOID HITTING THE PIPE, POLYETHYLENE WRAPPING, AND TRACER WIRE WHILE COMPACTION.

LIFT THREE – SHALL CONSIST OF PLACING AND COMPACTING MATERIAL TO 6" ABOVE THE PIPE.

② UPPER TRENCH ZONE (CLASS 2 AGGREGATE BASE) SHALL BE PLACED AND COMPACTED IN 12" LIFTS.

③ ASPHALT CONCRETE SHALL BE REPLACED IN KIND BUT NO LESS THAN 6" IN DEPTH.

④ MARKER TAPE TO BE INSTALLED 18" ABOVE WATER MAIN.

⑤ ENCASE DIP WITH V-BIO ENHANCED POLYETHYLENE ENCASUREMENT. TAPE A BLUE NO. 8 AWG COPPER TRACER WIRE TO TOP OF PIPE EVERY 6'.

⑥ A SECOND OPERATION IS REQUIRED PRIOR TO FINAL PAVING TO ACHIEVE THE "T" CUT SECTION. SAW CUTTING/GRINDING A WIDER TRENCH LINE DURING INITIAL TRENCH EXCAVATION TO ACHIEVE A "T" CUT SECTION IS NOT PERMITTED.

NOTES

1. REPLACE EXISTING TRACER WIRE IF DAMAGED DURING TRENCHING OPERATION. ON EXISTING STEEL PIPES, WELD THE NEW TRACER WIRE END TO THE STEEL PIPE IF TRACER WIRE IS NOT PRESENT.
2. IF WATER IS ENCOUNTERED IN THE TRENCH OR THE DISTRICT INSPECTOR DETERMINES THE SUBGRADE BELOW THE PIPE EMBEDMENT ZONE IS UNSTABLE, THE CONTRACTOR SHALL EXCAVATE AN ADDITIONAL 12" AND INSTALL 3/4" CRUSHED DRAIN ROCK. DRAIN ROCK SECTION SHALL BE WRAPPED WITH FILTER FABRIC ON ALL SIDES.

**TRENCH SECTION – TYPE A
PAVED SURFACES**

01/19
01/15
05/14
REV. 05/02



Approved by: *Tammy Rudock*
 Tammy Rudock, General Manager
 Joubin Pakpour, District Engineer, RCE
 No. 59155

**STD. NO.
MP-01**

LEGEND

① EMBEDMENT ZONE (QUARRY FINES) SHALL BE CONSTRUCTED IN THREE LIFTS:

LIFT ONE – SHALL CONSIST OF PLACING AND COMPACTING 4" OF MATERIAL PRIOR TO THE PLACEMENT OF THE PIPE. THE PIPE SHALL THEN BE PLACED PRIOR LIFT TWO.

LIFT TWO – SHALL CONSIST OF PLACING MATERIAL AROUND THE PIPE TO THE TOP OF THE PIPE. THE TOP OF THE PIPE SHALL BE VISIBLE PRIOR COMPACTION OF THE SECOND LIFT. COMPACTION AROUND THE PIPE SHALL BE PERFORMED BY PNEUMATIC MEANS SUCH AS A "POWDER PUFF." NO OTHER MEANS OF COMPACTION SHALL BE ALLOWED WITHOUT PRIOR APPROVAL BY THE DISTRICT. CONTRACTOR SHALL USE EXTREME CARE TO AVOID HITTING THE PIPE, POLYETHYLENE WRAPPING, AND TRACER WIRE WHILE COMPACTING.

LIFT THREE – SHALL CONSIST OF PLACING AND COMPACTING MATERIAL TO 6" ABOVE THE PIPE.

② UPPER TRENCH ZONE (CLASS 2 AGGREGATE BASE) SHALL BE PLACED AND COMPACTED IN 12" LIFTS.

③ MARKER TAPE TO BE INSTALLED 18" ABOVE WATER MAIN.

④ ENCASE DIP WITH V-BIO ENHANCED POLYETHYLENE ENCASEMENT. TAPE A BLUE NO. 8 AWG COPPER TRACER WIRE TO TOP OF PIPE EVERY 6'.

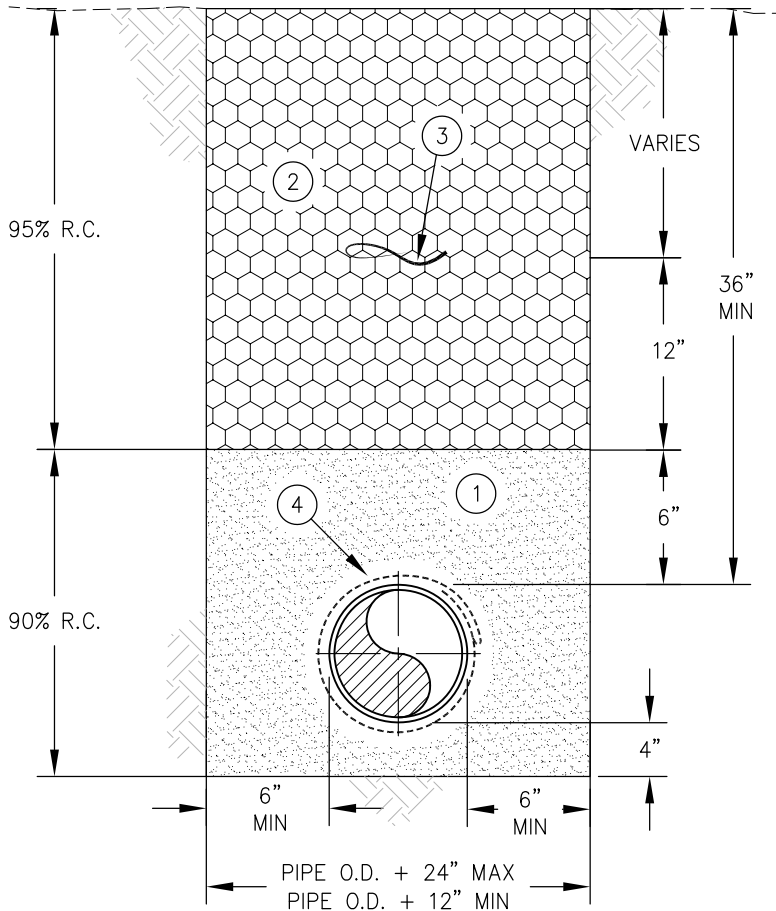

NOTES

1. REPLACE EXISTING TRACER WIRE IF DAMAGED DURING TRENCHING OPERATION. ON EXISTING STEEL PIPES, WELD THE NEW TRACER WIRE END TO THE STEEL PIPE IF TRACER WIRE IS NOT PRESENT.
2. IF WATER IS ENCOUNTERED IN THE TRENCH OR THE DISTRICT INSPECTOR DETERMINES THE SUBGRADE BELOW THE PIPE EMBEDMENT ZONE IS UNSTABLE, THE CONTRACTOR SHALL EXCAVATE AN ADDITIONAL 12" AND INSTALL 3/4" CRUSHED DRAIN ROCK. DRAIN ROCK SECTION SHALL BE WRAPPED WITH FILTER FABRIC ON ALL SIDES.

TRENCH SECTION – TYPE B
GRAVELED AREAS / ROAD SHOULDERS

REV. 01/19
 01/15
 05/14
 05/02



Approved by: *Tammy Rudock*
 Tammy Rudock, General Manager
 Joubin Pakpour, District Engineer, RCE
 No. 59155

STD. NO.
MP-02

LEGEND

① EMBEDMENT ZONE (QUARRY FINES) SHALL BE CONSTRUCTED IN THREE LIFTS:

LIFT ONE - SHALL CONSIST OF PLACING AND COMPACTING 4" OF MATERIAL PRIOR TO THE PLACEMENT OF THE PIPE. THE PIPE SHALL THEN BE PLACED PRIOR LIFT TWO.

LIFT TWO - SHALL CONSIST OF PLACING MATERIAL AROUND THE PIPE TO THE TOP OF THE PIPE. THE TOP OF THE PIPE SHALL BE VISIBLE PRIOR COMPACTION OF THE SECOND LIFT. COMPACTION AROUND THE PIPE SHALL BE PERFORMED BY PNEUMATIC MEANS SUCH AS A "POWDER PUFF." NO OTHER MEANS OF COMPACTION SHALL BE ALLOWED WITHOUT PRIOR APPROVAL BY THE DISTRICT. CONTRACTOR SHALL USE EXTREME CARE TO AVOID HITTING THE PIPE, POLYETHYLENE WRAPPING, AND TRACER WIRE WHILE COMPACTING.

LIFT THREE - SHALL CONSIST OF PLACING AND COMPACTING MATERIAL TO 6" ABOVE THE PIPE.

② UPPER TRENCH ZONE (NATIVE MATERIAL) SHALL BE PLACED AND COMPACTED IN 12" LIFTS.

③ MARKER TAPE TO BE INSTALLED 18" ABOVE WATER MAIN.

④ ENCASE DIP WITH V-BIO ENHANCED POLYETHYLENE ENCASEMENT. TAPE A BLUE NO. 8 AWG COPPER TRACER WIRE TO TOP OF PIPE EVERY 6'.

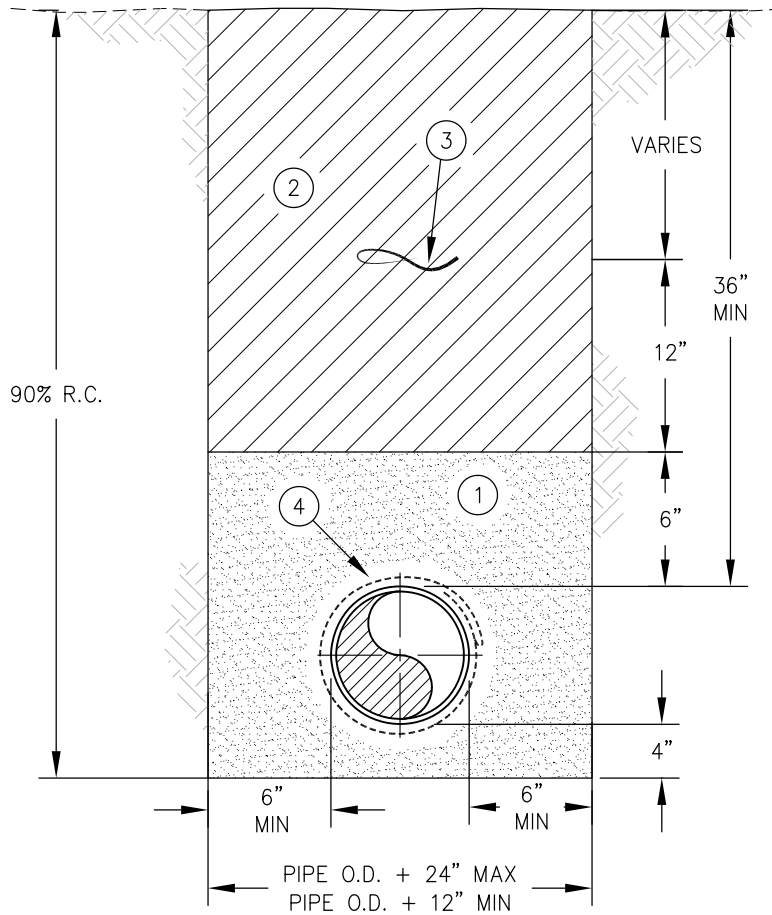

NOTES

1. REPLACE EXISTING TRACER WIRE IF DAMAGED DURING TRENCHING OPERATION. ON EXISTING STEEL PIPES, WELD THE NEW TRACER WIRE END TO THE STEEL PIPE IF TRACER WIRE IS NOT PRESENT.
2. IF WATER IS ENCOUNTERED IN THE TRENCH OR THE DISTRICT INSPECTOR DETERMINES THE SUBGRADE BELOW THE PIPE EMBEDMENT ZONE IS UNSTABLE, THE CONTRACTOR SHALL EXCAVATE AN ADDITIONAL 12" AND INSTALL 3/4" CRUSHED DRAIN ROCK. DRAIN ROCK SECTION SHALL BE WRAPPED WITH FILTER FABRIC ON ALL SIDES.

**TRENCH SECTION - TYPE C
UNIMPROVED AREA**

01/19
01/15
05/14
REV. 05/02



Approved by: *Tammy Rudock*
 Tammy Rudock, General Manager
 Joubin Pakpour, District Engineer, RCE
 No. 59155

**STD. NO.
MP-03**

SAW-CUT/GRIND PAVEMENT FULL DEPTH. MAINTAIN EDGE TRUE FOR REPAVING. IF EDGE IS DAMAGED IT SHALL BE RECUT BEFORE PAVING. A TACK COAT SHALL BE APPLIED TO ALL SURFACES BEFORE PAVING. TRENCH LINES SHALL BE SAND SEALED. IF THE TRENCH EDGE FALLS WITHIN 3' OF THE GUTTER LIP OR OUTER SHOULDER EDGE, THE ENTIRE PAVEMENT SECTION BETWEEN THE TRENCH EDGE AND GUTTER LIP/OUTER SHOULDER EDGE SHALL BE REPLACED.

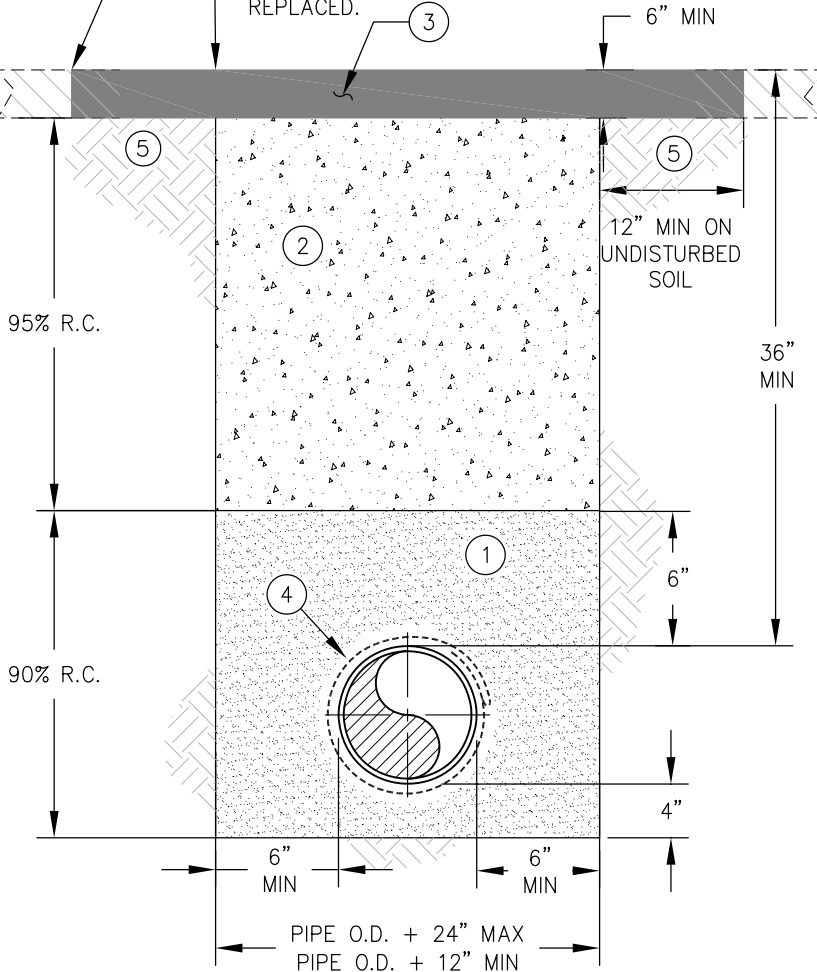

LEGEND

- ① EMBEDMENT ZONE (QUARRY FINES) SHALL BE PLACED IN THREE LIFTS:

LIFT ONE - SHALL CONSIST OF PLACING AND COMPACTING 4" OF MATERIAL PRIOR TO THE PLACEMENT OF THE PIPE. THE PIPE SHALL THEN BE PLACED PRIOR LIFT TWO.

LIFT TWO - SHALL CONSIST OF PLACING MATERIAL AROUND THE PIPE TO THE TOP OF THE PIPE. THE TOP OF THE PIPE SHALL BE VISIBLE PRIOR COMPACTION OF THE SECOND LIFT. COMPACTION AROUND THE PIPE SHALL BE PERFORMED BY PNEUMATIC MEANS SUCH AS A "POWDER PUFF." NO OTHER MEANS OF COMPACTION SHALL BE ALLOWED WITHOUT PRIOR APPROVAL BY THE DISTRICT. CONTRACTOR SHALL USE EXTREME CARE TO AVOID HITTING THE PIPE, POLYETHYLENE WRAPPING, AND TRACER WIRE WHILE COMPACTING.

LIFT THREE - SHALL CONSIST OF PLACING AND COMPACTING MATERIAL TO 6" ABOVE THE PIPE.
- ② UPPER TRENCH ZONE (CONTROLLED DENSITY FILL).
- ③ ASPHALT CONCRETE SHALL BE REPLACED IN KIND BUT NO LESS THAN 6" IN DEPTH.
- ④ ENCASE DIP WITH V-BIO ENHANCED POLYETHYLENE ENCASEMENT. TAPE A BLUE NO. 8 AWG COPPER TRACER WIRE TO TOP OF PIPE EVERY 6'.
- ⑤ A SECOND OPERATION IS REQUIRED PRIOR TO FINAL PAVING TO ACHIEVE THE "T" CUT SECTION. SAW CUTTING/GRINDING A WIDER TRENCH LINE DURING INITIAL TRENCH EXCAVATION TO ACHIEVE A "T" CUT SECTION IS NOT PERMITTED.

NOTES

- 1. REPLACE EXISTING TRACER WIRE IF DAMAGED DURING TRENCHING OPERATION. ON EXISTING STEEL PIPES, WELD THE NEW TRACER WIRE END TO THE STEEL PIPE IF TRACER WIRE IS NOT PRESENT.
- 2. IF WATER IS ENCOUNTERED IN THE TRENCH OR THE DISTRICT INSPECTOR DETERMINES THE SUBGRADE BELOW THE PIPE EMBEDMENT ZONE IS UNSTABLE, THE CONTRACTOR SHALL EXCAVATE AN ADDITIONAL 12" AND INSTALL 3/4" CRUSHED DRAIN ROCK. DRAIN ROCK SECTION SHALL BE WRAPPED WITH FILTER FABRIC ON ALL SIDES.

TRENCH SECTION - TYPE D
CONTROLLED DENSITY FILL

01/19
01/15
05/14
REV. 05/02



**MID-PENINSULA
WATER DISTRICT**

Approved by:

Tammy Rudock

Tammy Rudock, General Manager

Joubin Pakpour, District Engineer, RCE
No. 59155

STD. NO.
MP-04

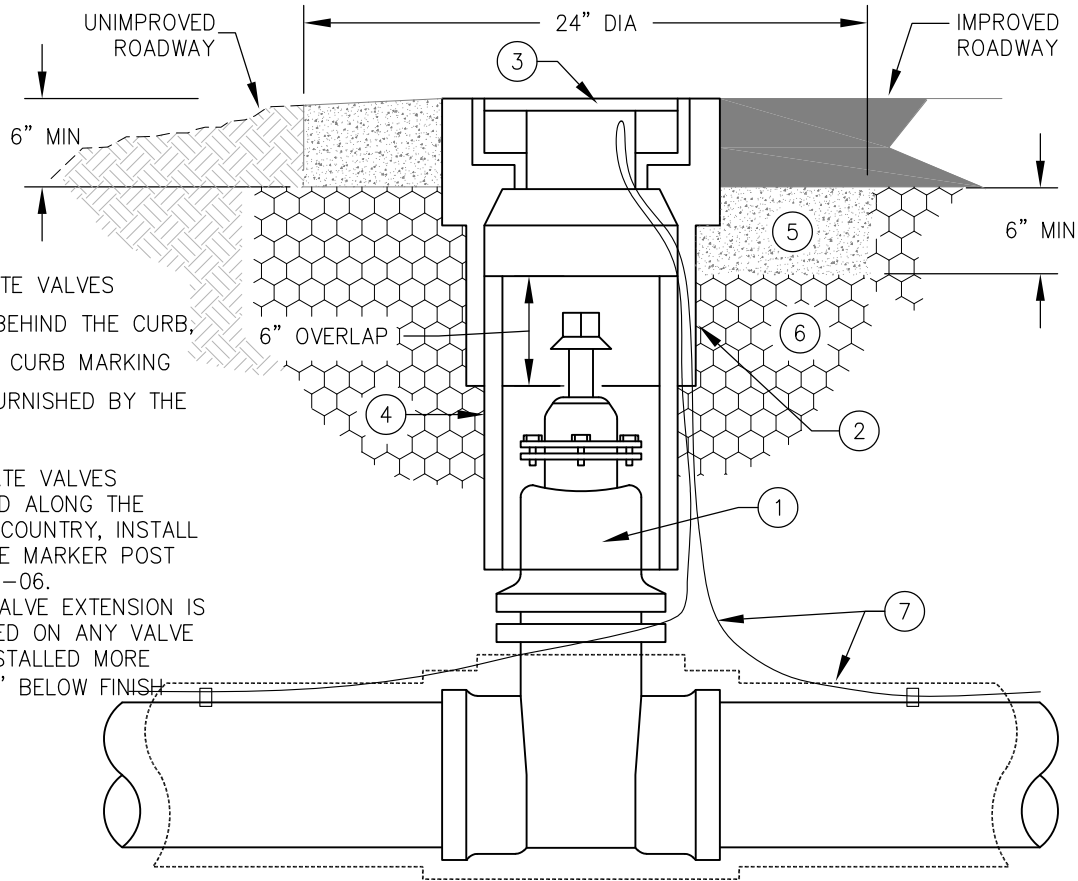

NOTES

1. FOR GATE VALVES LOCATED BEHIND THE CURB, INSTALL A CURB MARKING TAG AS FURNISHED BY THE DISTRICT.
2. FOR GATE VALVES LOCATED ALONG THE CROSS COUNTRY, INSTALL A VALVE MARKER POST PER MP-06.
3. GATE VALVE EXTENSION IS REQUIRED ON ANY VALVE NUT INSTALLED MORE THAN 3' BELOW FINISH GRADE.

LEGEND

- ① GATE VALVE, MUELLER NO. A-2362 WITH TYPE 316 SS BOLTS AND NUTS, AND 2" SQUARE BRONZE OPERATION NUT. VALVE STEM SHALL BE BRONZE; EPDM RUBBER; MACHINED RELEASE GROOVE BELOW OPERATING NUT; AND STUFFING BOX ALIGNED WITH THE DIRECTION OF THE PIPE. IF COATING ON GATE VALVE IS DAMAGED DURING THE INSTALLATION, IT SHOULD BE REPAIRED USING MUELLER APPROVED VALVE REPAIR EPOXY KIT. VALVE SHALL BE SET PLUMB.
- ② TRAFFIC VALVE BOX, CHRISTY CONCRETE NO. G05TBOX.
- ③ CAST IRON TRAFFIC COVER INSCRIBED "WATER", CHRISTY CONCRETE NO. G05CT.
- ④ SDR 35 PVC PIPE - 8" MIN DIA.
- ⑤ 2,000 PSI HIGH EARLY STRENGTH CONCRETE. PLACE ASPHALT ON TOP OF CONCRETE COLLAR, SAME DAY.
- ⑥ TRENCH BACKFILL PER MP-01 THRU MP-04
- ⑦ ENCASE DIP WITH V-BIO ENHANCED POLYETHYLENE ENCASUREMENT. WRAP EXCESS FILM WITH 10-MIL PIPE TAPE. USE NO. 8 AWG STANDARD TRACER WIRE TAPED ON TOP OF PIPE AND LOOPED INTO THE VALVE BOX FROM OUTSIDE THE RISER. WIRE TO EXTEND 12" ABOVE GRADE.

GATE VALVE ASSEMBLY

04/21
 01/19
 01/15
 05/14
 REV. 05/02



Approved By: *Tammy Rudock*
 Tammy Rudock, General Manager
 Joubin Pakpour, District Engineer, RCE
 No. 59155

STD. NO.
MP-05

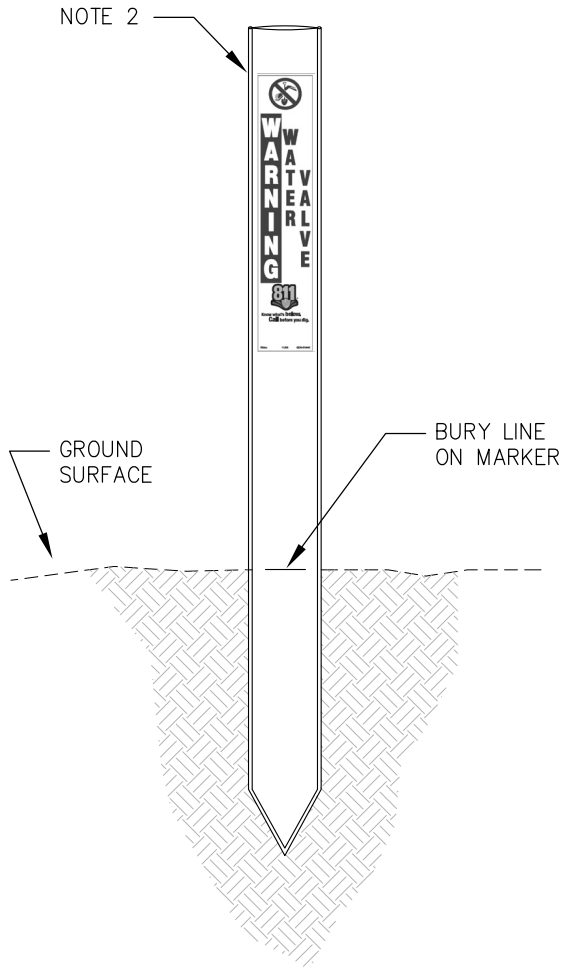

NOTES:

1. THE MARKER POST SHALL BE 4" HYBRID 4-RAIL 72" POST, MANUFACTURER BY RHINO MARKING SYSTEM. THE COLOR OF THE POST SHALL BE BLUE.
2. STANDARD WARNING LEGENDS GD8-1333K FOR "WATER PIPELINE" AND GD-5194K FOR "WATER VALVE".
3. MARKER POST TO BE LOCATED IN THE FIELD BY THE DISTRICT.

**WATER VALVE/WATER MAIN
MARKER POST**

REV. 04/21
01/19
05/14



**MID-PENINSULA
WATER DISTRICT**

Approved by

Tammy Rudock, General Manager

Joubin Pakpour, District Engineer, RCE
No. 59155

**STD. NO.
MP-06**

**VOLUME OF GRAVITY BLOCK
IN CUBIC YARDS**

VERTICAL FITTING	DIAMETER OF PIPE					
	6"	8"	10"	12"	14"	16"
90°	1.0	2.0	3.0	4.0	5.0	6.0
45°	0.5	1.0	1.5	2.0	2.5	3.0

VERTICAL BEND

SIZE OF ROD DETERMINED BY DISTRICT

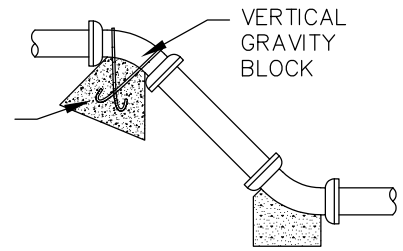

HORIZONTAL BENDS

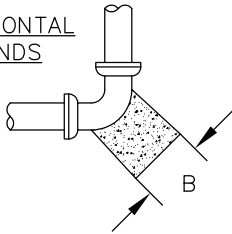

PLUGGED RUN

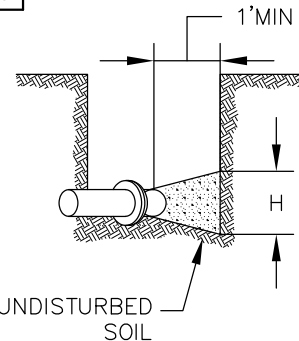
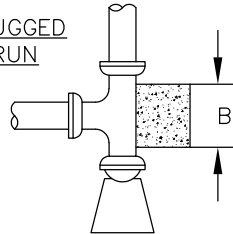

THRUST BLOCK PROFILE

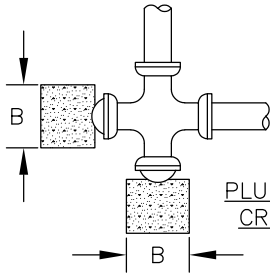

PLUGGED CROSS

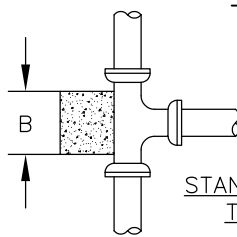

STANDARD TEE

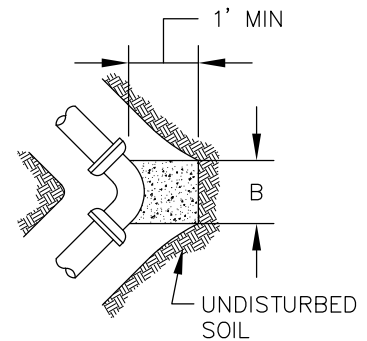

THRUST BLOCK PLAN

DIMENSIONS OF THRUST BLOCKS IN FEET

HORIZONTAL FITTING	DIAMETER OF PIPE											
	6"		8"		10"		12"		14"		16"	
	B	H	B	H	B	H	B	H	B	H	B	H
90°	1'-9"	1'-9"	2'-3"	2'-3"	2'-9"	2'-9"	3'-3"	3'-3"	3'-9"	3'-9"	4'-3"	4'-3"
45°	1'-0"	1'-0"	1'-6"	1'-6"	2'-0"	2'-0"	2'-6"	2'-6"	3'-0"	3'-0"	3'-6"	3'-6"
PLUG/TEE	1'-3"	1'-3"	1'-9"	1'-9"	2'-3"	2'-3"	2'-9"	2'-9"	3'-3"	3'-3"	3'-9"	3'-9"

NOTES

- THRUST BLOCK DIMENSIONS SHALL BE DOUBLED IF USED ON NON-RESTRAINED CONNECTIONS.
- USE 2,000 PSI HIGH EARLY STRENGTH CONCRETE.
- ALL THRUST BLOCKS AND GRAVITY BLOCKS SHALL BEAR AGAINST UNDISTURBED EARTH.
- ENCASE DIP IN V-BIO ENHANCED POLYETHYLENE ENCASUREMENT.
- MAINTAIN A MIN CLEARANCE OF 2" BETWEEN THE THRUST BLOCK REINFORCING STEEL AND PIPE.
- CONCRETE NOT TO EXTEND BEYOND THE FACE OF THE BELL.
- THRUST BLOCK SHALL ENCOMPASS AT LEAST ONE-HALF OF THE OUTSIDE DIAMETER OF THE PIPE.
- FLANGES, BOLTS, AND NUTS SHALL BE KEPT CLEAR OF CONCRETE.
- DIMENSIONS ABOVE INCLUDE USE OF MECHANICAL RESTRAINTS ON PIPE.
- IF GROUNDWATER IS PRESENT, THRUST BLOCK DIMENSIONS SHALL BE DETERMINED BY THE DISTRICT.

THRUST BLOCK DETAILS

01/19
01/15
05/14
REV. 05/02



**MID-PENINSULA
WATER DISTRICT**

Approved by

Tammy Rudock

Tammy Rudock, General Manager

Joubin Pakpour, District Engineer, RCE
No. 59155

**STD. NO.
MP-07**

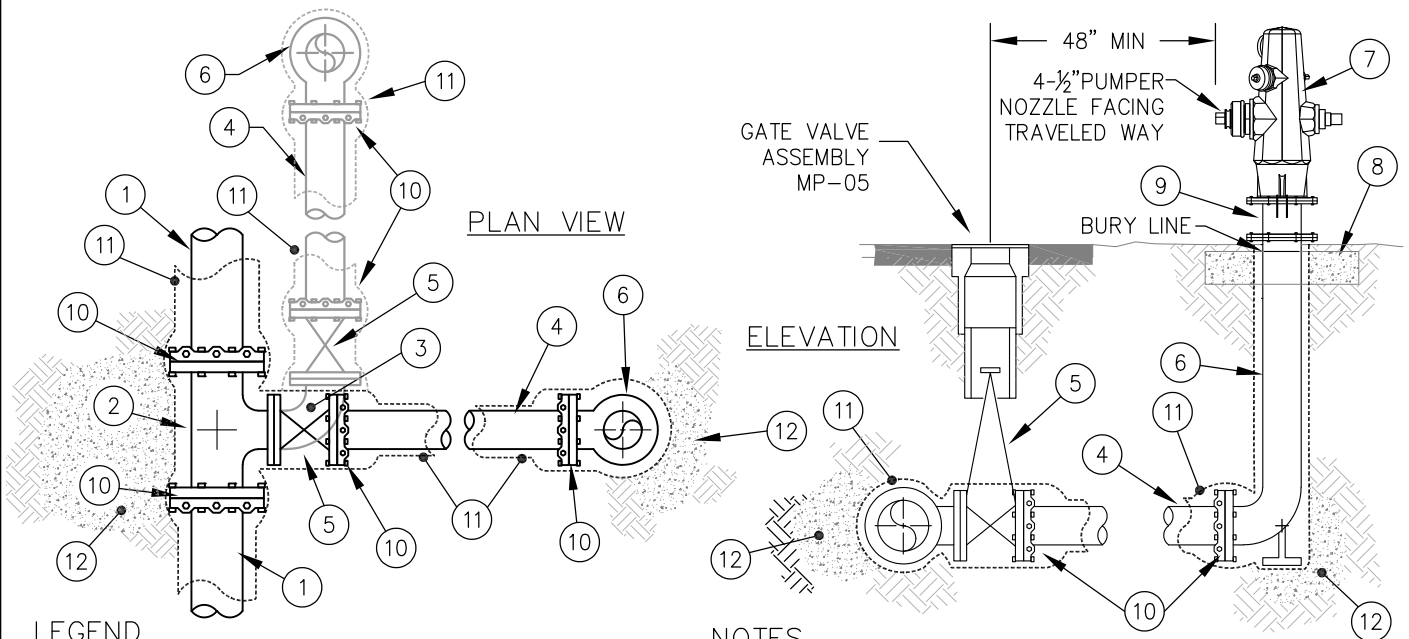

LEGEND

- ① WATER MAIN, DIP OR PVC
- ② TEE (TYPE DETERMINED BY DISTRICT) OR TAPPING SLEEVE, JMC 6432, ALL TYPE 316 SS BODIES, OR AS DIRECTED BY THE DISTRICT
- ③ 6" 90° BEND, FLXFL.
- ④ 6" DIP OR PVC PIPE.
- ⑤ 6" GATE VALVE, MUELLER A-2362, FLXMJ (RESTRAINED)
- ⑥ 6" BURY, FLXMJ (RESTRAINED)
- ⑦ HYDRANT, CLOW 860 (WET BARREL) WITH ONE 4-½" PUMPER AND TWO 2-½" OUTLETS, ALL NS THREADS.
- ⑧ 24"DIA, 12" THICK, 2,000 PSI CONCRETE COLLAR.
- ⑨ BREAK-OFF CHECK VALVE, MUELLER J6000. INSTALL CONCRETE COLLAR ⑧ TO ALLOW REMOVAL OF STAINLESS STEEL BOLTS SECURING BREAK-OFF RISER. NATIVE SOIL SHALL THEN BE PLACED ON TOP OF THE COLLAR TO WITHIN 1" OF THE BOTTOM OF THE BREAK-OFF RISER.
- ⑩ 6" MJ RESTRAINT, EBAA IRON, "MEGALUG" SERIES 1100 FOR DIP AND SERIES 2000 FOR PVC.
- ⑪ ENCASE DIP FIRE HYDRANT LATERAL WITH V-BIO ENHANCED POLYETHYLENE ENCASEMENT. WRAP EXCESS FILM WITH 10 MIL PIPE TAPE. TAPE A BLUE NO. 8 AWG, COPPER TRACER WIRE TO THE TOP OF LATERAL.
- ⑫ THRUST BLOCK PER MP-07

NOTES

- 1. FOR NEW DEVELOPMENTS, THE CONTRACTOR SHALL COORDINATE WITH THE LOCAL FIRE DEPARTMENT FOR HYDRANT LOCATIONS.
- 2. ALL JOINTS USED IN THE HYDRANT ASSEMBLY SHALL BE RESTRAINED AND SHALL BE MECHANICAL JOINT "MEGALUG," OR FIELD LOCKS.
- 3. BREAK-OFF RISER SHALL BE 1" ABOVE FINISH GRADE.
- 4. ALL BOLTS AND NUTS SHALL BE TYPE 316 STAINLESS STEEL EXCLUDING PRE-MANUFACTURED BREAK-OFF CHECK VALVE.
- 5. INSTALL A BLUE, TWO-WAY, REFLECTIVE PAVEMENT MARKER AT EACH HYDRANT LOCATION IN ACCORDANCE WITH APPLICABLE PORTIONS OF SECTION 85 OF THE CALTRANS STANDARD SPECIFICATIONS.
- 6. PAINT BOTH THE TOP SURFACE OF THE FIRE HYDRANT GATE VALVE BOX AND COVER WHITE WITH DIRECT TO METAL PAINT.
- 7. NEW FIRE HYDRANT ASSEMBLY SHALL BE PRESSURE TESTED AND DISINFECTED.
- 8. NEW FIRE HYDRANT AND BREAK OFF CHECK VALVE SHALL BE FACTORY PAINTED "WHITE." ALL METAL ABOVE THE CONCRETE COLLAR SHALL ALSO BE PAINTED "WHITE."

FIRE HYDRANT ASSEMBLY

04/21
01/19
01/15
05/14
11/04
REV.



Approved by *Tammy Rudock*
 Tammy Rudock, General Manager
 Joubin Pakpour, District Engineer, RCE
 No. 59155

STD. NO.
MP-08

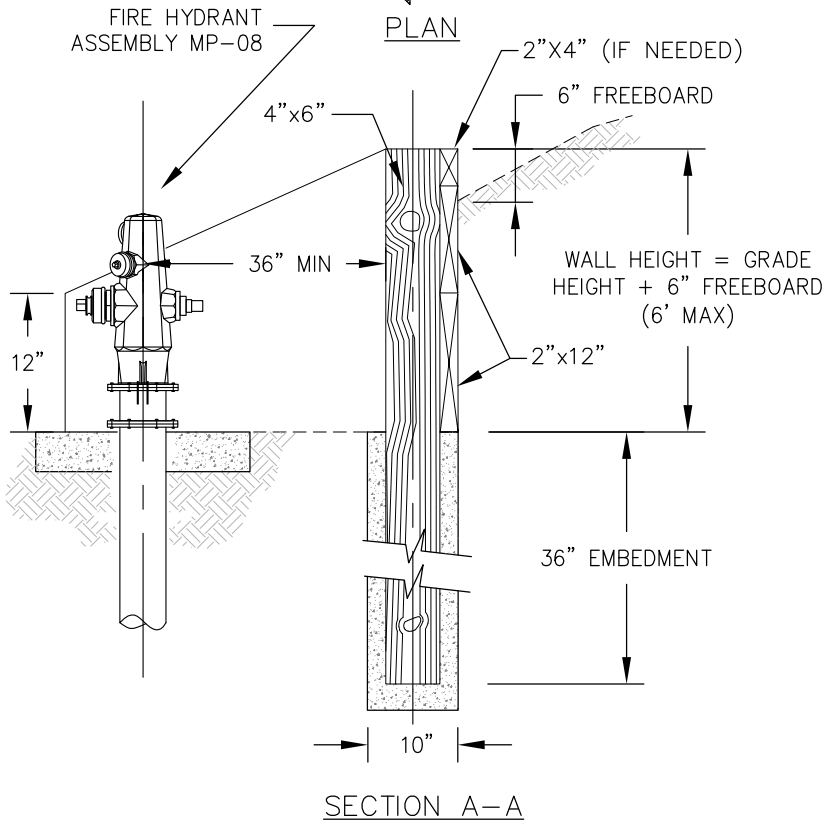
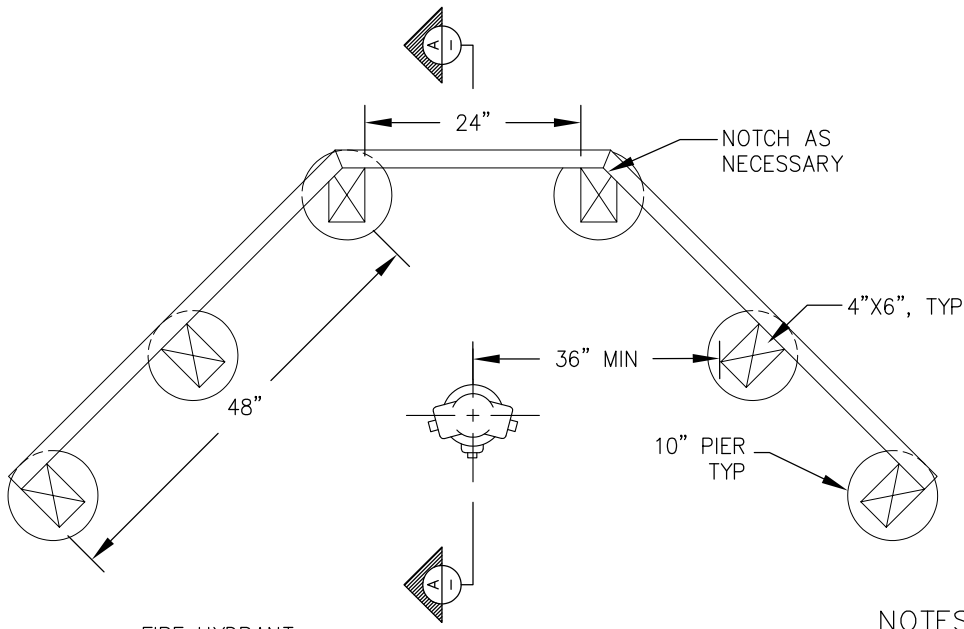

NOTES

1. ALL LUMBER SHALL BE PRESSURE TREATED LUMBER WITH 0.40 LBS/CF RETENTION OR GREATER.
2. ALL DIMENSIONS SHOWN ARE FOR A TYPICAL RETAINING WALL. FIELD CONDITIONS MAY REQUIRE DEVIATION FROM DETAIL. CONTRACTOR SHALL VERIFY SITE CONDITIONS AND OBTAIN APPROVAL FROM THE DISTRICT BEFORE MAKING CHANGES.

FIRE HYDRANT RETAINING WALL

REV. 01/19
01/15
05/14



Approved by:
Tammy Rudock
Tammy Rudock, General Manager
Joubin Pakpour
Joubin Pakpour, District Engineer, RCE
No. 59155

**STD. NO.
MP-09**

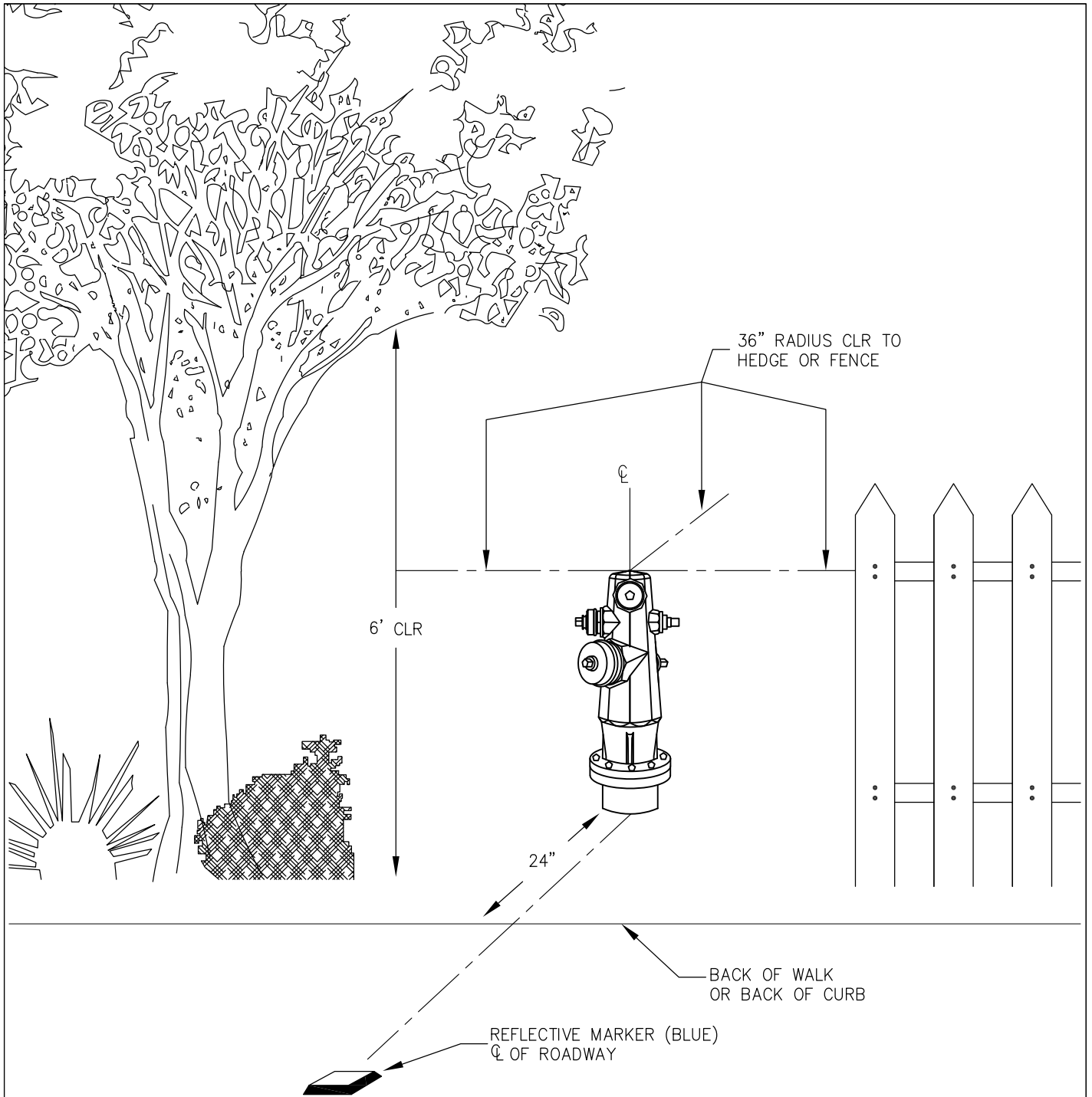

HYDRANT CLEARANCES

REV. 01/19
05/14



**MID-PENINSULA
WATER DISTRICT**

Approved by:

Tammy Rudock

Tammy Rudock, General Manager

Joubin Pakpour, District Engineer, RCE
No. 59155

STD. NO.

MP-10

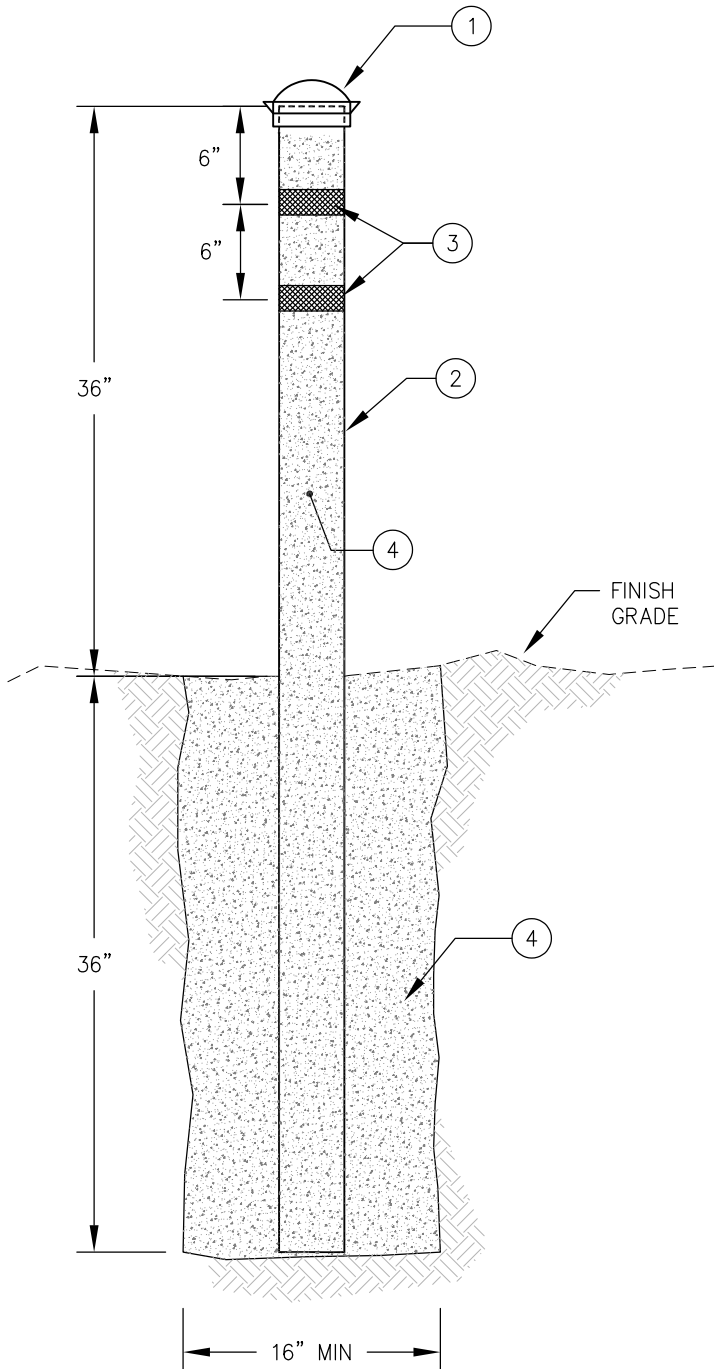

LEGEND

- ① 4" GALVANIZED TAP ON CAP.
- ② 4" DIA GALVANIZED STEEL PIPE FILLED WITH CLASS 2 CONCRETE. PIPE SHALL BE PAINTED WHITE WITH DIRECT TO METAL (DTM) HIGH PERFORMANCE INDUSTRIAL COATINGS SYSTEM (MINIMUM TWO COATS).
- ③ 2" YELLOW DOT-C2 REFLECTIVE TAPE
- ④ CLASS 2 CONCRETE

NOTES

1. BOLLARD LOCATIONS TO BE LOCATED IN THE FIELD BY THE DISTRICT.
2. BOLLARDS SHALL BE PERMANENT UNLESS SPECIFIED BY THE DISTRICT.
3. REMOVABLE BOLLARDS SHALL BE MODEL PW/BRL-PG&E MANUFACTURED BY PLACER WATER WORKS, INC. TO BE POWDER COATED WHITE, WITH 2-2" YELLOW COLOR REFLECTIVE TAPE, DOT-C2.

BOLLARD

01/19
01/15
REV. 05/14



**MID-PENINSULA
WATER DISTRICT**

Approved by:

Tammy Rudock, General Manager

Joubin Pakpour, District Engineer, RCE
No. 59155

**STD. NO.
MP- 11**

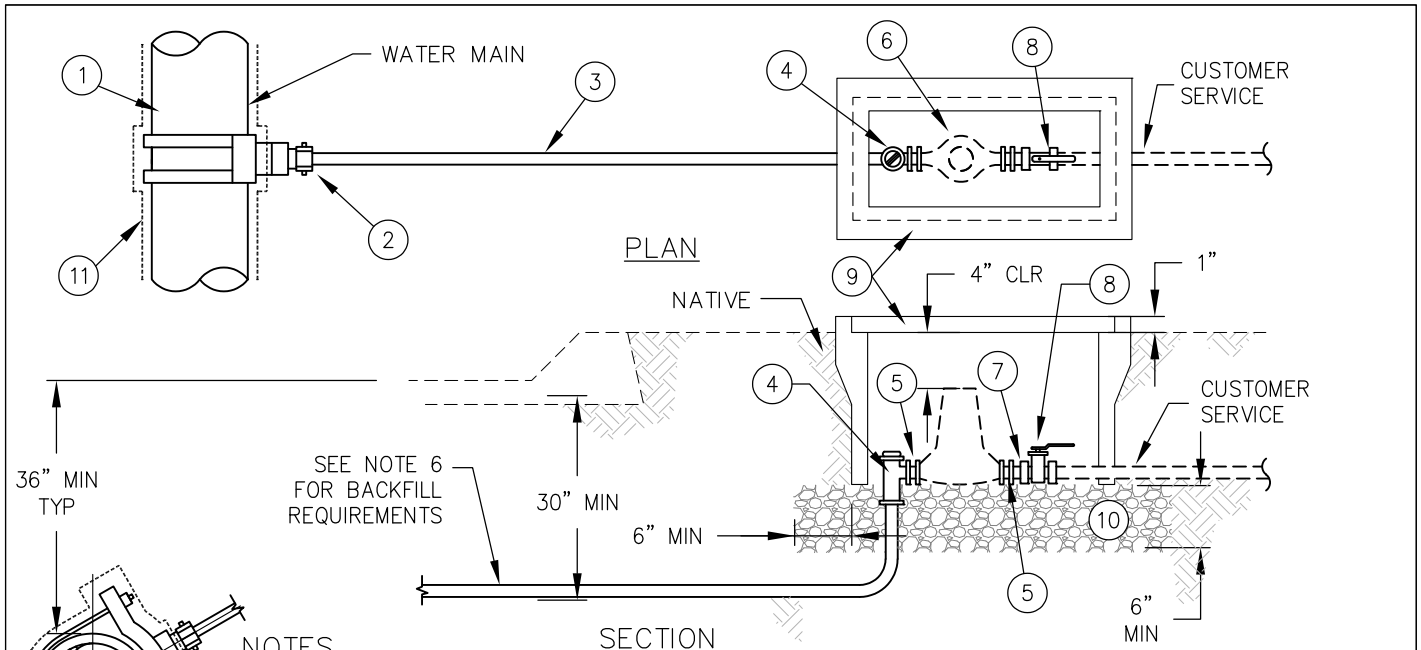

NOTES

1. METERS SHALL BE INSTALLED IN A LEVEL, HORIZONTAL POSITION AND SHALL BE PERPENDICULAR TO THE CURB. NO METERS SHALL BE PLACED ON PRIVATE PROPERTY.
2. APPLICATIONS FOR SERVICES LARGER THAN 1" REQUIRE HYDRAULIC CALCULATION JUSTIFICATION AND PRIOR APPROVAL FROM THE DISTRICT.
3. USE MUELLER PACK JOINT V-15442 (FEMALE) OR V-15440 (MALE) WHEN CUSTOMER SERVICE IS PVC.
4. HOT-TAPS AND NEW CONNECTIONS SHALL BE 4' MIN FROM A BELL/JOINT OR AS DIRECTED BY THE DISTRICT.
5. SERVICE SADDLE SHALL BE 18" MIN FROM AN ADJACENT SERVICE CONNECTION.
6. IF OPEN TRENCH METHOD IS USED, EMBEDMENT MATERIAL (QUARRY FINES) SHALL BE PLACED 2" BELOW AND 6" ABOVE THE SERVICE LINE. BACKFILL AND COMPACT REMAINING SECTION PER APPLICABLE MP-01 THRU MP-04.
7. ANY FIRE SPRINKLER INSTALLATION WILL REQUIRE AN UPDATED SERVICE CONNECTION.

LEGEND

- ① DOUBLE STRAP BRONZE SERVICE SADDLE, MUELLER BR2B "CC" FOR DIP AND MUELLER BR2S "CC" FOR PVC.
- ② 1" INSULATED CORPORATION STOP, MUELLER N-35008N.
- ③ 1" TYPE K SOFT COPPER PIPE. COPPER PIPE SHALL HAVE BLUE SEAMLESS POLYETHYLENE COAT DISTRIBUTED BY MUELLER STREAMLINE CO. UNIONS OR COUPLINGS NOT PERMITTED.
- ④ 1" COMPRESSION BALL ANGLE METER VALVE, MUELLER B-24258N.
- ⑤ FORD A-XX-NL METER ADAPTERS, (BRASS), SHALL BE INSTALLED ON THE INLET AND OUTLET SIDES OF THE METER TO UPSIZE/DOWNSIZE THE METER SIZE AND LENGTH AS REQUIRED.
- ⑥ 5/8" OR 1" METER (FURNISHED BY DISTRICT).
- ⑦ INSULATED METER COUPLING, MUELLER H-10871N.
- ⑧ BALL VALVE, RED WHITE VALVE 5044AB.
- ⑨ METER BOX, CHRISTY NO. B16 WITH NO. B16P REINFORCED CONCRETE COVER. H/20, TRAFFIC RATED BOX AND COVER, ARMORCAST 20K, NO. A6000492 AND A6000489TH, SHALL BE PROVIDED IN TRAFFIC AREAS AND WHERE DIRECTED BY THE DISTRICT. COVERS SHALL HAVE A RECESSED PROBE HOLE MADE FOR SENSUS FLEXNET RADIO READERS.
- ⑩ 3/4" DRAIN ROCK SHALL BE MECHANICALLY COMPACTED.
- ⑪ ENCASE DIP WITH V-BIO ENHANCED POLYETHYLENE ENCASEMENT.

5/8" OR 1" SERVICE CONNECTION

REV. 04/21
 01/19
 01/15
 05/14
 05/02



Approved by *Tammy Rudock*
 Tammy Rudock, General Manager
 Joubin Pakpour, District Engineer, RCE
 No. 59155

STD. NO.
MP-12

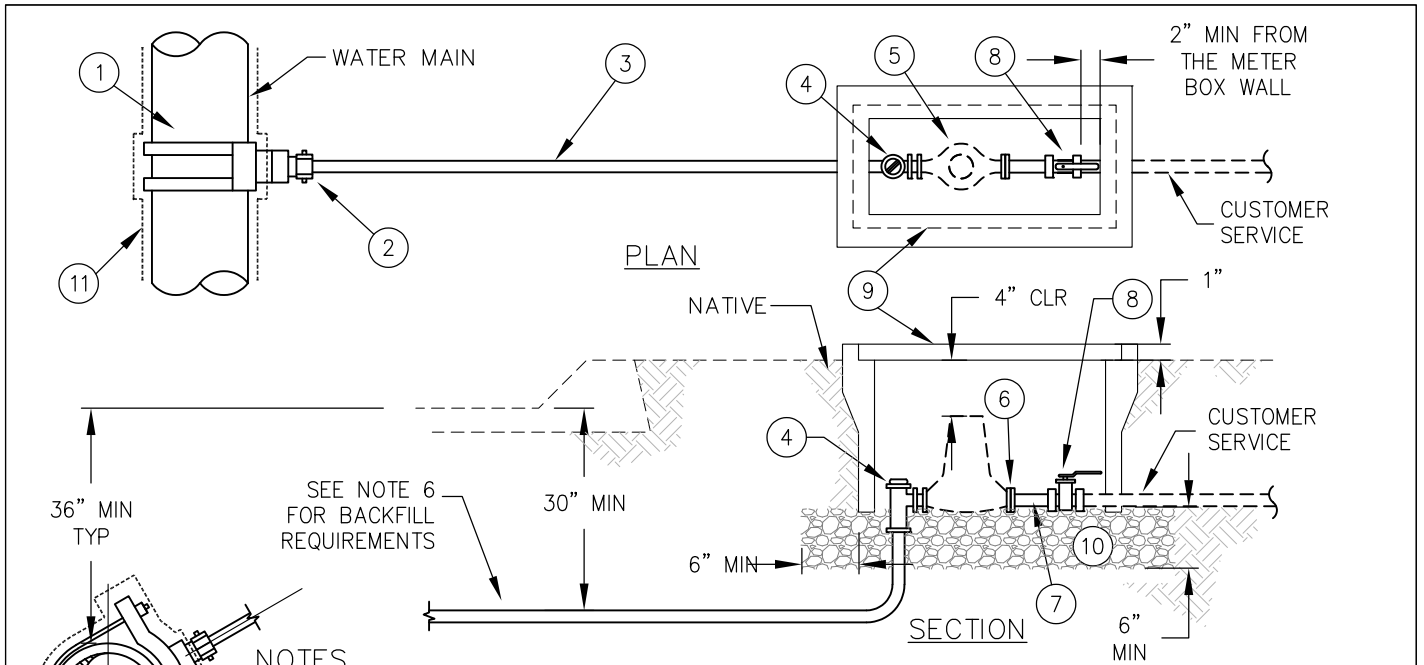

NOTES

1. METERS SHALL BE INSTALLED IN A LEVEL, HORIZONTAL POSITION AND SHALL BE PERPENDICULAR TO THE CURB. NO METERS SHALL BE PLACED ON PRIVATE PROPERTY.
2. APPLICATIONS FOR SERVICES LARGER THAN 1" REQUIRE HYDRAULIC CALCULATION JUSTIFICATION AND PRIOR APPROVAL FROM THE DISTRICT.
3. USE MUELLER PACK JOINT V-15442 (FEMALE) OR V-15440 (MALE) WHEN CUSTOMER SERVICE IS PVC.
4. HOT-TAPS AND NEW CONNECTIONS SHALL BE 4' MIN FROM A BELL/JOINT OR AS DIRECTED BY THE DISTRICT.
5. SERVICE SADDLE SHALL BE 18" MIN FROM AN ADJACENT SERVICE CONNECTION.
6. IF OPEN TRENCH METHOD IS USED, EMBEDMENT MATERIAL (QUARRY FINES) SHALL BE PLACED 2" BELOW AND 6" ABOVE THE SERVICE LINE. BACKFILL AND COMPACT REMAINING SECTION PER APPLICABLE MP-01 THRU MP-04
7. ANY FIRE SPRINKLER INSTALLATION WILL REQUIRE AN UPDATED SERVICE CONNECTION.

LEGEND

- ① DOUBLE STRAP BRONZE SERVICE SADDLE, MUELLER BR2B "CC" FOR DIP AND MUELLER DR2S "CC" FOR PVC.
- ② 2" INSULATED CORPORATION STOP, MUELLER N-35008N.
- ③ 2" TYPE K SOFT COPPER PIPE. COPPER PIPE SHALL HAVE BLUE SEAMLESS POLYETHYLENE COAT DISTRIBUTED BY MUELLER STREAMLINE CO. UNIONS OR COUPLINGS NOT PERMITTED.
- ④ 2" COMPRESSION BALL ANGLE METER VALVE, MUELLER B-24276N.
- ⑤ 1-1/2" OR 2" METER (FURNISHED BY DISTRICT).
- ⑥ 1-1/2" OR 2" BRASS METER FLANGE (LOW LEAD).
- ⑦ 1-1/2" OR 2" BRASS NIPPLE (LOW LEAD).
- ⑧ 1-1/2" OR 2" BALL VALVE, RED WHITE VALVE 5044AB.
- ⑨ METER BOX, CHRISTY NO. FL30T WITH NO. FL30P FIBERLYTE COVER. H/20 TRAFFIC RATED BOX AND COVER, SHALL BE PROVIDED IN TRAFFIC AREAS AND WHERE DIRECTED BY THE DISTRICT. COVERS SHALL HAVE A RECESSED PROBE HOLE MADE FOR SENSUS FLEXNET RADIO READERS.
- ⑩ 3/4" DRAIN ROCK SHALL BE MECHANICALLY COMPACTED.
- ⑪ ENCASE DIP WITH V-BIO ENHANCED POLYETHYLENE ENCASEMENT.

**1 1/2" OR 2" RESIDENTIAL
SERVICE CONNECTION**

04/21
01/19
01/15
05/14
REV. 05/02



Approved by: *Tammy Rudock*
 Tammy Rudock, General Manager
 Joubin Pakpour, District Engineer, RCE
 No. 59155

**STD. NO.
MP-13**

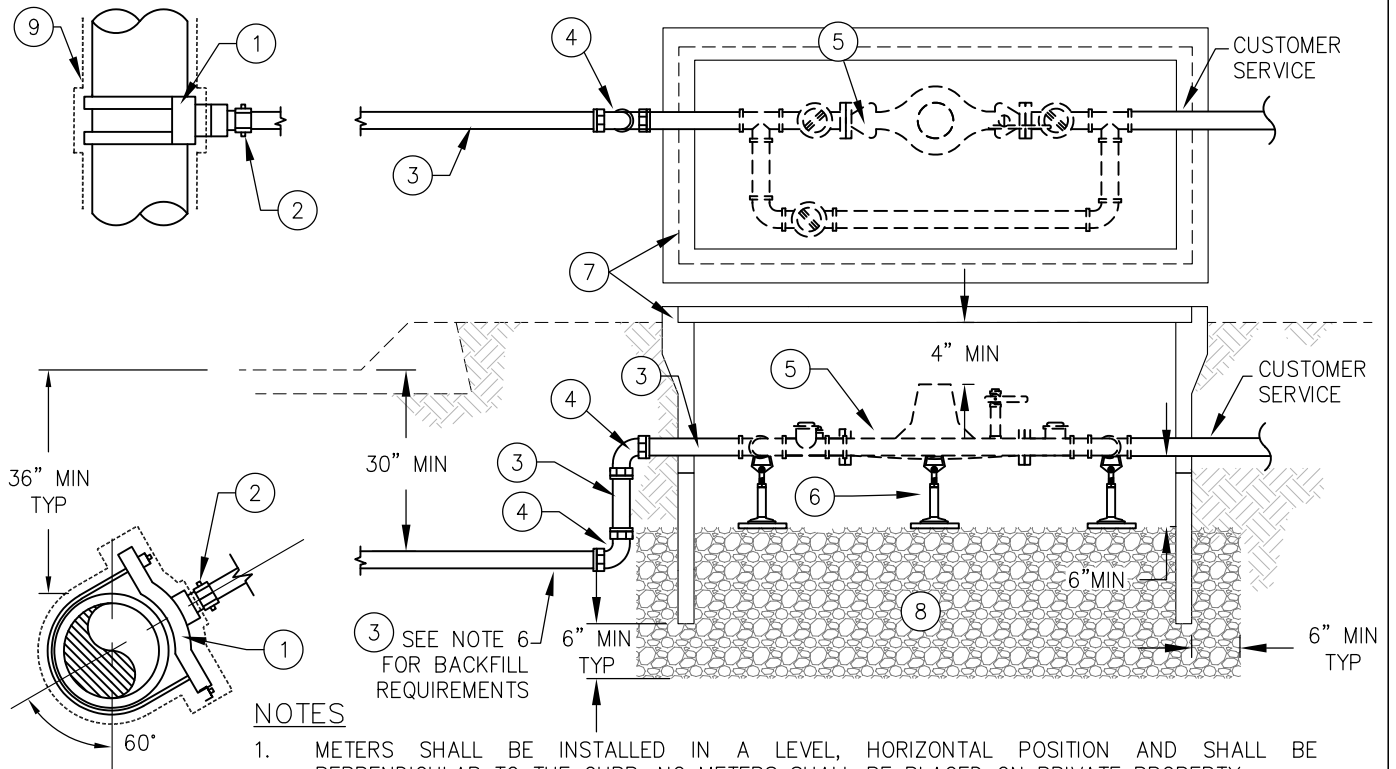

NOTES

1. METERS SHALL BE INSTALLED IN A LEVEL, HORIZONTAL POSITION AND SHALL BE PERPENDICULAR TO THE CURB. NO METERS SHALL BE PLACED ON PRIVATE PROPERTY.
2. APPLICATIONS FOR SERVICES LARGER THAN 1" REQUIRE HYDRAULIC CALCULATION JUSTIFICATION AND PRIOR APPROVAL FROM THE DISTRICT. DRAWINGS FOR ANY METER LARGER THAN 2" SHALL BE SUBMITTED TO THE DISTRICT FOR APPROVAL.
3. USE MUELLER PACK JOINT V-15442 (FEMALE) OR V-15440 (MALE) WHEN CUSTOMER SERVICE IS PVC.
4. HOT-TAPS AND NEW CONNECTIONS SHALL BE 4' MIN FROM A BELL/JOINT OR AS DIRECTED BY THE DISTRICT.
5. SERVICE SADDLE SHALL BE 18" MIN AWAY FROM AN ADJACENT SERVICE CONNECTION.
6. IF OPEN TRENCH METHOD IS USED, EMBEDMENT MATERIAL (QUARRY FINES) SHALL BE PLACED 2" BELOW AND 6" ABOVE THE SERVICE LINE. BACKFILL AND COMPACT REMAINING SECTION PER APPLICABLE MP-01 THRU MP-04.

LEGEND

- ① DOUBLE STRAP BRONZE SERVICE SADDLE, MUELLER BR2B "CC" FOR DIP AND MUELLER BR2S "CC" FOR PVC.
- ② 2" INSULATED CORPORATION STOP, MUELLER N-35008N.
- ③ 2" TYPE K SOFT COPPER PIPE. COPPER PIPE SHALL HAVE BLUE SEAMLESS POLYETHYLENE COAT DISTRIBUTED BY MUELLER STREAMLINE CO. UNIONS OR COUPLINGS NOT PERMITTED.
- ④ 2" MUELLER 110 COMPRESSION CONNECTION H-15526N.
- ⑤ 1-1/2" OR 2" METER WITH BYPASS ASSEMBLY (FURNISHED BY DISTRICT).
- ⑥ PIPE SUPPORT.
- ⑦ METER BOX, CHRISTY B48 WITH EXTENSION AND N48-62D-P STEEL COVER. H/20 TRAFFIC RATED BOX AND COVER SHALL BE PROVIDED IN TRAFFIC AREAS AND WHERE DIRECTED BY THE DISTRICT. COVERS SHALL HAVE A RECESSED PROBE HOLE MADE FOR SENSUS FLEXNET RADIO READERS.
- ⑧ 3/4" DRAIN ROCK SHALL BE MECHANICALLY COMPACTED.
- ⑨ ENCASE DIP WITH V-BIO ENHANCED POLYETHYLENE ENCASEMENT.

**1 1/2" AND 2" SERVICE CONNECTION
WITH BYPASS**

REV. 04/21
01/19
01/15
05/14



Approved by: *Tammy Rudock*
 Tammy Rudock, General Manager
 Joubin Pakpour, District Engineer, RCE
 No. 59155

**STD. NO.
MP-14**

NOTES

1. METER BOXES SHALL BE SET PARALLEL TO THE SERVICE LINE FOLLOWING THE CONTOUR OF EXISTING GROUND, UNLESS A RETAINING WALL IS REQUIRED.
2. AFTER THE BOX IS SET AND ALIGNED WITH THE METER, THE CONTRACTOR MAY USE NATIVE MATERIAL OR AGGREGATE BASE TO BACKFILL AROUND THE BOX. BACKFILL WITHIN 12" PERIMETER OF THE BOX SHALL BE COMPACTED TO 90% R.C. CONTRACTOR SHALL USE CARE NOT TO DAMAGE THE METER BOX.
3. METER BOX SHALL PROJECT 1" ABOVE GRADE WHEN LOCATED IN NON-TRAFFIC AREAS AND SHALL BE FLUSH WITH PAVEMENT WHEN LOCATED IN TRAFFIC AREAS AND PATHWAYS.
4. AFTER THE BOX HAS BEEN SET AND COMPACTED, ANY DEBRIS AND DIRT INSIDE THE BOX SHALL BE REMOVED/DISPOSED OF TO THE SATISFACTION OF THE DISTRICT.

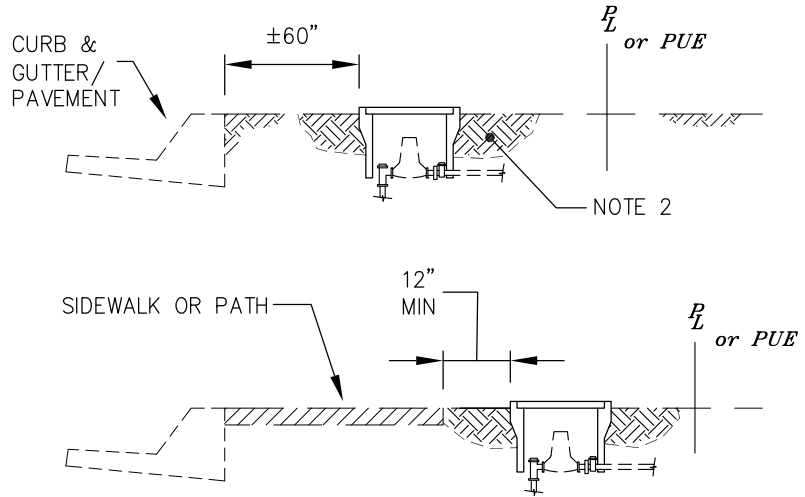

METER LOCATION

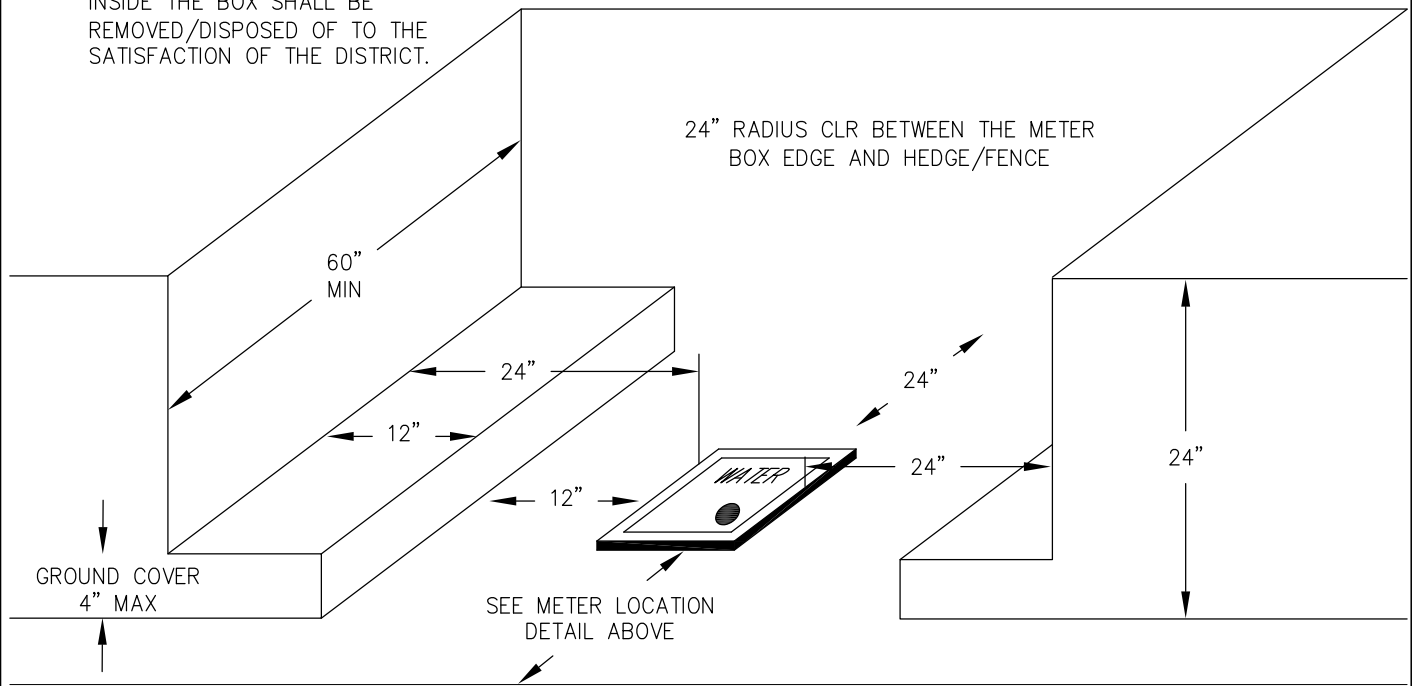

METER CLEARANCES

SERVICE METER CLEARANCES

01/19
REV. 05/14



**MID-PENINSULA
WATER DISTRICT**

Approved by:

Tammy Rudock

Tammy Rudock, General Manager

Joubin Pakpour, District Engineer, RCE
No. 59155

**STD. NO.
MP-15**

NOTES

1. IF OPEN TRENCH METHOD IS USED, EMBEDMENT MATERIAL (QUARRY FINES) SHALL BE PLACED 2" BELOW AND 6" ABOVE COPPER LINE. BACKFILL AND COMPACT REMAINING SECTION PER APPLICABLE MP-01 THRU MP-04.
2. SIZES OF PIPE, FITTINGS, VALVES, CORPORATION STOPS SHALL MATCH THE SIZE OF THE COMBINATION AIR VALVE AS SPECIFIED BY THE DISTRICT.
3. CONCRETE BASE SHALL BE 2" ABOVE FINISHED GRADE OR LEVEL WITH SIDEWALK/PAVEMENT GRADE.
4. CONTINUOUS COPPER TUBING MAY BE USED BETWEEN THE WATER MAIN AND COMBINATION AIR VALVE IF CLEARANCES ALLOW OR AS DIRECTED BY THE DISTRICT.
5. IF THE STATIC PRESSURE IS LESS THAN 25 PSI, CONTRACTOR SHALL NOTIFY THE MANUFACTURER PRIOR TO ORDERING THE VALVE.
6. 1" COMBINATION AIR VALVE SHALL BE INSTALLED FOR MAINS 8" OR SMALLER. 2" COMBINATION AIR VALVE SHALL BE INSTALLED FOR MAINS 10" OR LARGER.
7. ENCASE DIP WITH V-BIO ENHANCED POLYETHYLENE ENCASEMENT.

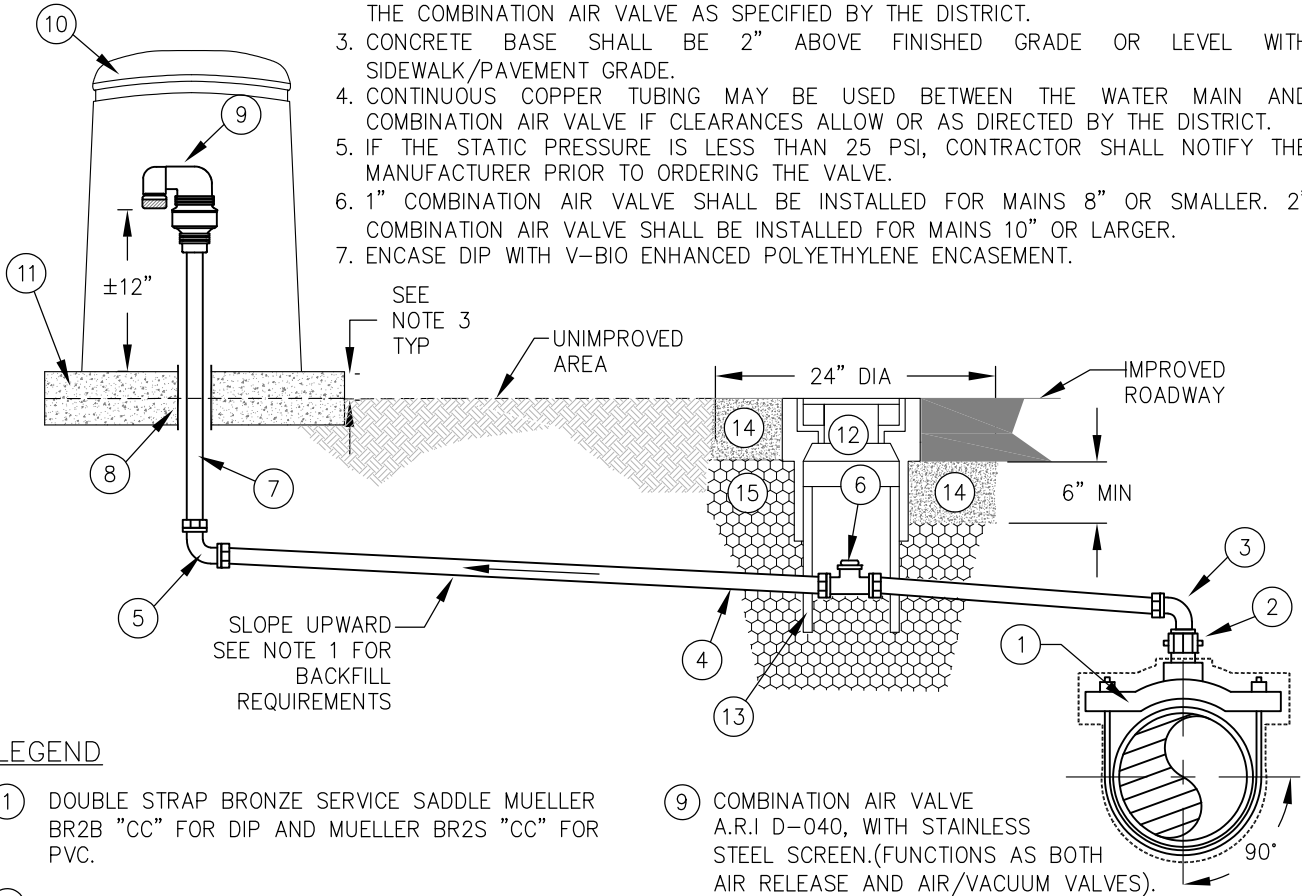

LEGEND

- | | |
|--|---|
| <ul style="list-style-type: none"> ① DOUBLE STRAP BRONZE SERVICE SADDLE MUELLER BR2B "CC" FOR DIP AND MUELLER BR2S "CC" FOR PVC. ② INSULATED CORPORATION STOP, MUELLER N-30045N (CCXFIP). ③ 90° MIP X COMP MUELLER FITTING. ④ TYPE K COPPER TUBING. COPPER PIPE SHALL HAVE BLUE SEAMLESS POLYETHYLENE COAT DISTRIBUTED BY MUELLER STREAMLINE CO. MAINTAIN UPWARD SLOPE. UNIONS OR COUPLINGS NOT PERMITTED. ⑤ 90° COMP X COMP MUELLER FITTING. ⑥ F.I.P X F.I.P BALL STRAIGHT METER VALVE, MUELLER B-20200N. ⑦ BRASS PIPE (LOW LEAD). ⑧ SDR 35 PVC - 3" DIA. | <ul style="list-style-type: none"> ⑨ COMBINATION AIR VALVE A.R.I D-040, WITH STAINLESS STEEL SCREEN.(FUNCTIONS AS BOTH AIR RELEASE AND AIR/VACUUM VALVES). ⑩ ENCLOSURE PIPELINE PRODUCTS, VCAS-1424. COLOR SHALL BE GREEN AND INSTALLED LEVEL. (PADLOCK FURNISHED BY DISTRICT) ⑪ CONCRETE BASE 4"H X 24"DIA W/STEEL WIRE MESH IN MIDDLE. BASE SHALL BE INSTALLED LEVEL. ⑫ TRAFFIC VALVE BOX, CHRISTY CONCRETE NO. G05T WITH CAST IRON TRAFFIC COVER INSCRIBED "WATER", CHRISTY CONCRETE NO G05CT. ⑬ SDR 35 PVC RISER - 8" MIN DIA. ⑭ 2,000 PSI CONCRETE COLLAR. 24 HOURS MIN CURE PRIOR TO PLACEMENT OF ASPHALT. ⑮ BACKFILL MATERIAL PER APPLICABLE MP-01 THRU MP-04 |
|--|---|

1" OR 2" COMBINATION AIR VALVE

04/21
01/19
01/15
05/14
05/02
REV.



**MID-PENINSULA
WATER DISTRICT**

Approved By

Tammy Rüdock

Tammy Rüdock, General Manager

Joubin Pakpour, District Engineer, RCE
No. 59155

**STD. NO.
MP-16**

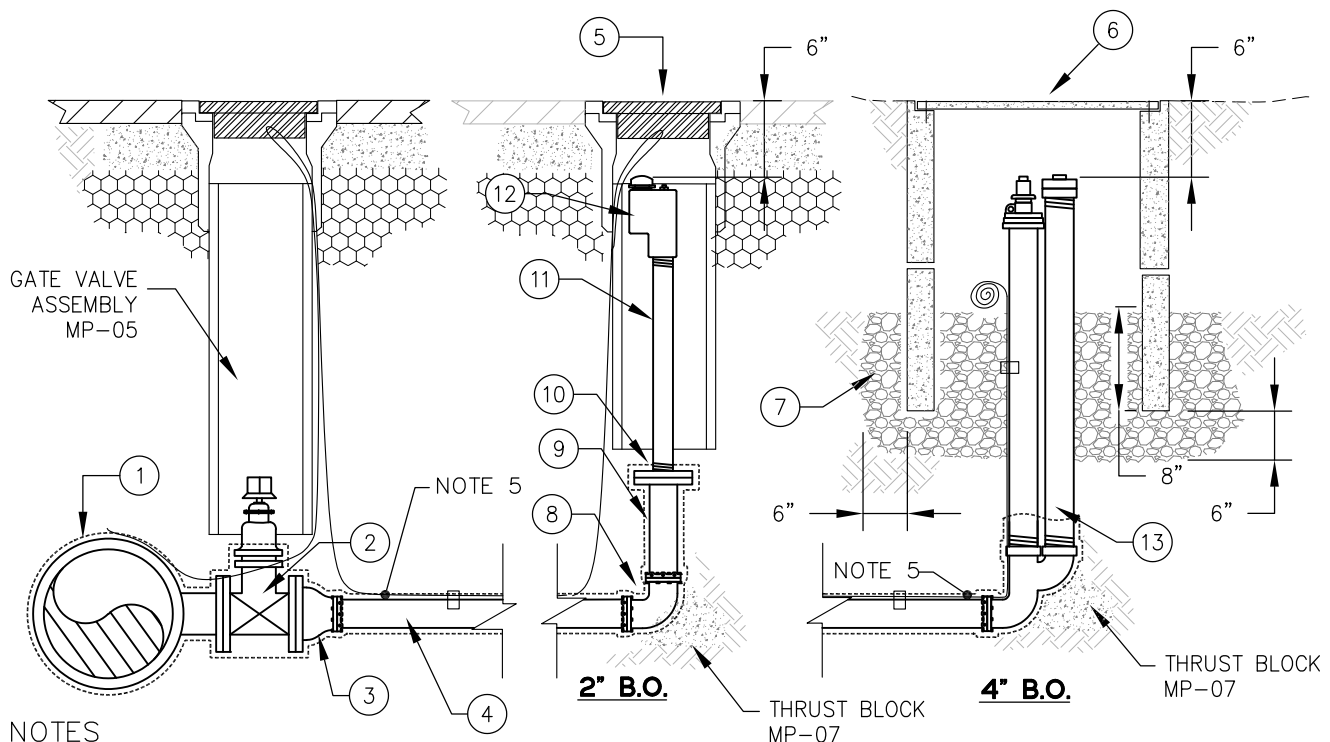

NOTES

1. 2" BLOW-OFF SHALL BE INSTALLED FOR MAINS 6" OR SMALLER.
2. 4" BLOW-OFF SHALL BE INSTALLED FOR MAINS 8" OR LARGER.
3. THE TOP OF THE BOX SHALL BE FLUSH WITH PAVEMENT WHEN LOCATED IN TRAFFIC AREAS.
4. ALL BURIED NUTS AND BOLTS SHALL BE TYPE 316 STAINLESS STEEL.
5. ENCASE BRANCH TEE, BENDS, NIPPLES, AND DIP IN V-BIO ENHANCED POLYETHYLENE ENCASMENT. TAPE A BLUE NO. 8 AWG, COPPER TRACER WIRE TO THE TOP OF PIPE EVERY 6'.

LEGEND

- | | |
|---|--|
| <ul style="list-style-type: none"> ① 4" BRANCH TEE (TYPE DETERMINED BY DISTRICT) OR TAPPING SLEEVE JMC 6432, FOR 4" MAINS, OR 6" BRANCH TEE (TYPE DETERMINED BY DISTRICT) OR TAPPING SLEEVE JMC 6432, FOR 6" AND BIGGER MAINS. ② GATE VALVE, FLXFL, MUELLER NO. 2362. ③ 6"x4" REDUCER, FLXMJ (RESTRAINED) FOR 6" MAINS AND BIGGER. <p><u>2" BLOW-OFF</u></p> <ul style="list-style-type: none"> ⑧ 4" DIP 90° BEND, MJXMJ (RESTRAINED). ⑨ 4" DIP FLXPE OR PVC WITH RESTRAINED FLANGED ADAPTER. ⑩ 4" COMPANION FLANGE WITH A 2" THREADED IP OUTLET. ⑪ 2" BRASS NIPPLE, 8"MIN. ⑫ 2" BLOWOFF/FLUSHING HYDRANT, TRUFLO MODEL TF550 MANUFACTURED BY KUPFERLE FOUNDRY CO. (BRASS LOW LEAD) | <ul style="list-style-type: none"> ④ 4" DIP/PVC. ⑤ TRAFFIC VALVE BOX WITH CAST IRON COVER INSCRIBED "WATER", INSTALL PER MP-05. ⑥ TRAFFIC BOX, CHRISTY NO. B1324BOX (H/20 LOADING) WITH B1324-61JH STEEL CHECKER PLATE COVER AND B1324X12 EXTENSION. ⑦ 3/4" DRAIN ROCK, UP TO VALVE ONLY, SHALL BE MECHANICALLY COMPACTED . <p><u>4" BLOW-OFF</u></p> <ul style="list-style-type: none"> ⑬ 4" BLOWOFF/FLUSHING HYDRANT, MAINGUARD MODEL 7600 MANUFACTURED BY KUPFERLE FOUNDRY CO. |
|---|--|

BLOW-OFF ASSEMBLY

01/19
01/15
05/14
REV. 05/02



Approved by: *Tammy Rudock*
 Tammy Rudock, General Manager
 Joubin Pakpour, District Engineer, RCE
 No. 59155

STD. NO.
MP-17

NOTES

1. SERVICE SADDLE SHALL BE 18" MIN FROM AN ADJACENT SERVICE CONNECTION.
2. EMBEDMENT MATERIAL (QUARRY FINES) SHALL BE PLACED 2" BELOW AND 6" ABOVE COPPER LINE. BACKFILL AND COMPACT REMAINING SECTION PER MP-01 THRU MP-04.
3. A 24"X24" CONCRETE COLLAR SHALL BE INSTALLED 2" ABOVE FINISHED GRADE OR LEVEL IN SIDEWALK AND PAVEMENT AREAS.
4. FILL HOUSING WITH PEA GRAVEL.
5. ENCASE DIP WITH V-BIO ENHANCED POLYETHYLENE ENCASEMENT.

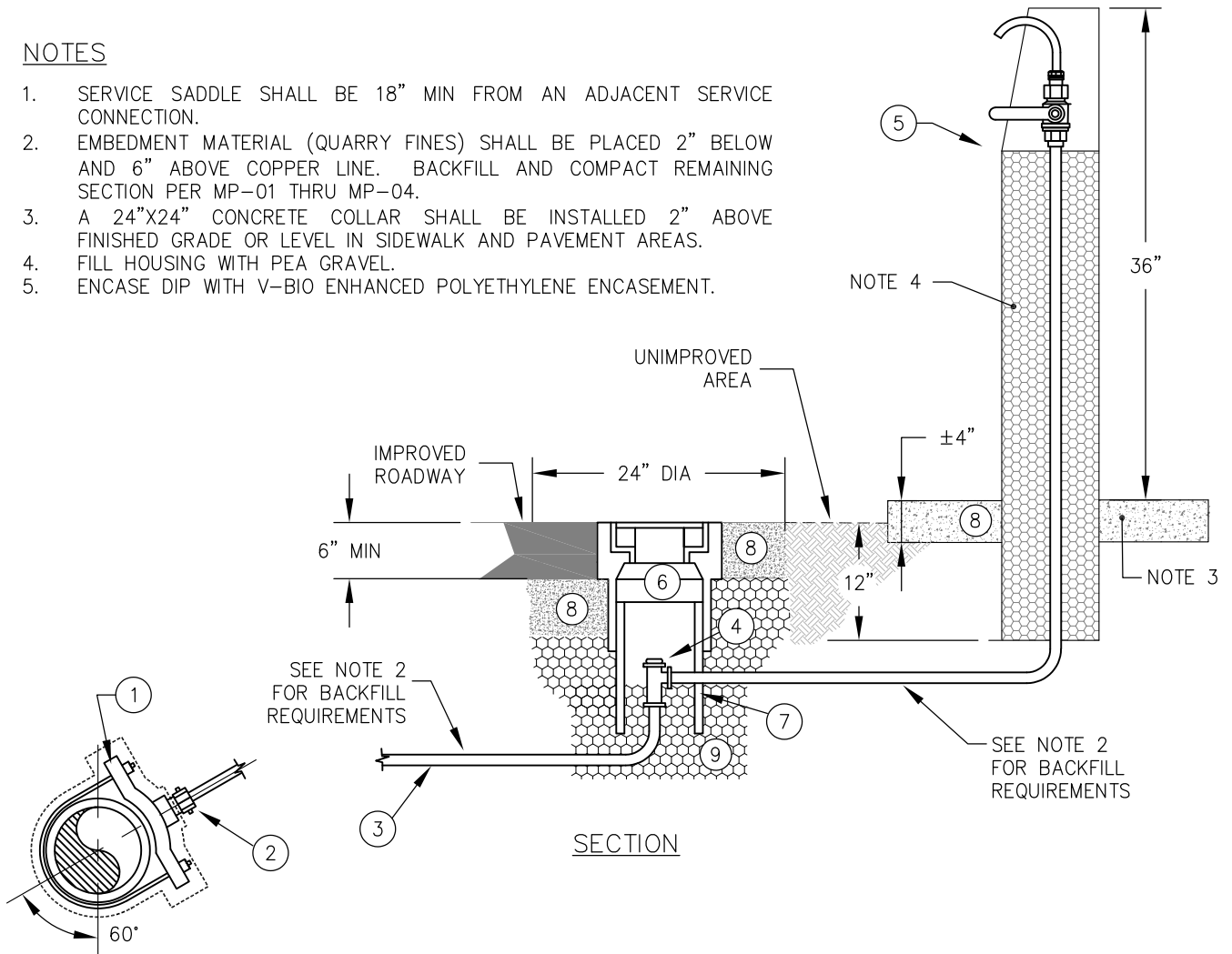

LEGEND

- | | |
|---|---|
| <p>① DOUBLE STRAP BRONZE SERVICE SADDLE MUELLER BR2B "CC" FOR DIP AND MUELLER BR2S "CC" FOR PVC.</p> <p>② 3/4" INSULATED CORPORATION STOP, MUELLER B-25008N.</p> <p>③ 3/4" TYPE K SOFT COPPER PIPE. COPPER PIPE SHALL HAVE BLUE SEAMLESS POLYETHYLENE COAT DISTRIBUTED BY MUELLER STREAMLINE CO. UNIONS OR COUPLINGS NOT PERMITTED.</p> <p>④ 3/4" COMPRESSION BALL ANGLE METER VALVE, MUELLER B-24258N.</p> | <p>⑤ SAMPLING STATION, KORALEEN XLT.</p> <p>⑥ TRAFFIC VALVE BOX, CHRISTY CONCRETE NO. G05TBOX, WITH CAST IRON TRAFFIC COVER INSCRIBED "WATER", CHRISTY CONCRETE NO. G05CT.</p> <p>⑦ SDR 35 PVC RISER - 8" MIN DIA.</p> <p>⑧ 2,000 PSI CONCRETE COLLAR. 24 HOURS MIN CURE PRIOR TO PLACEMENT OF ASPHALT.</p> <p>⑨ BACKFILL MATERIAL PER APPLICABLE MP-01 THRU MP-04.</p> |
|---|---|

SAMPLING STATION

04/21
01/19
REV. 05/14



Approved by: *Tammy Rudock*
 Tammy Rudock, General Manager
 Joubin Pakpour, District Engineer, RCE
 No. 59155

STD. NO.
MP-18

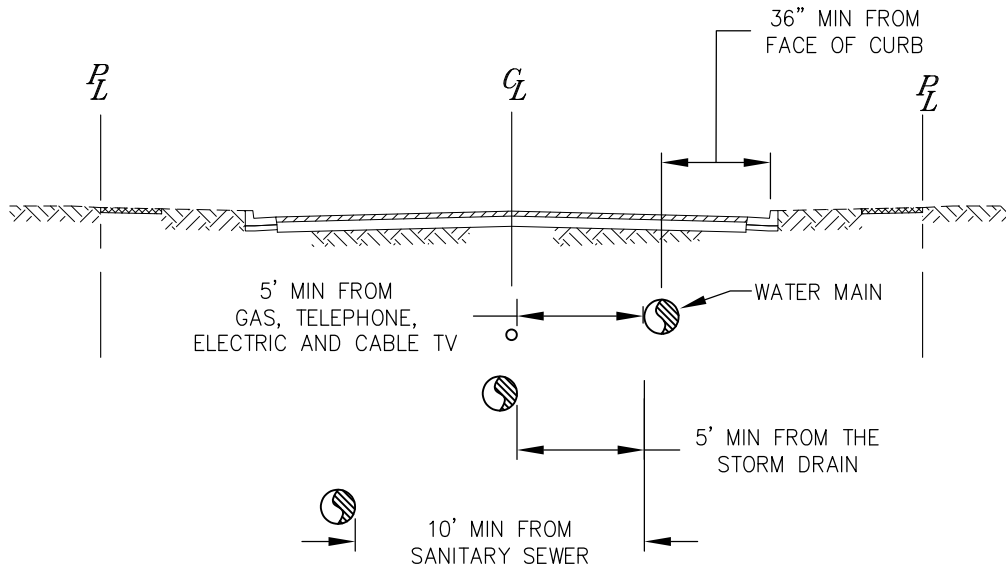

MINIMUM REQUIRED HORIZONTAL CLEARANCE FROM WATER MAIN

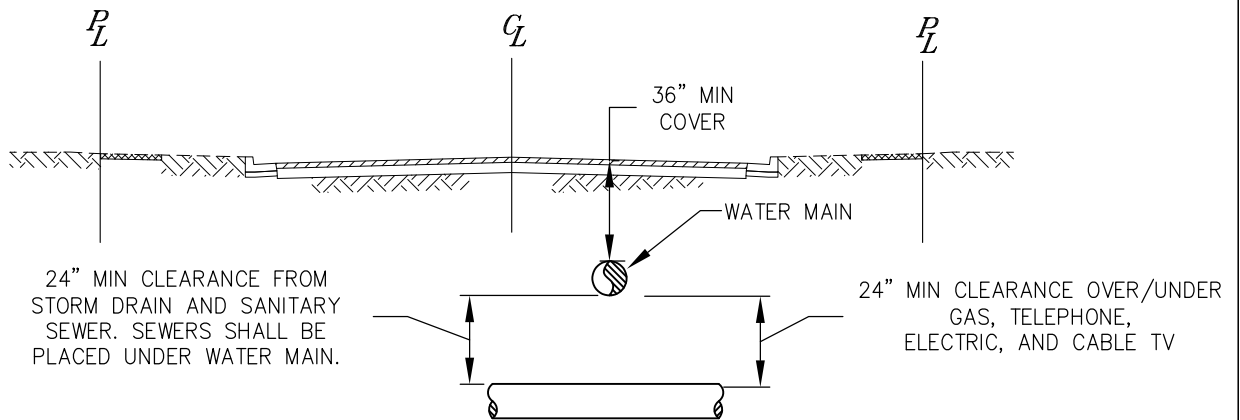

MINIMUM REQUIRED VERTICAL CLEARANCE FROM WATER MAIN AT CROSSINGS

NOTES

1. ANY DEVIATION FROM THESE REQUIREMENTS REQUIRES WRITTEN APPROVAL FROM THE DISTRICT.
2. ALL CROSSINGS SHALL BE AT 45° TO 90°.
3. NO CONNECTION JOINTS SHALL BE MADE IN THE WATER MAIN WITHIN EIGHT HORIZONTAL FEET OF THE STORM DRAIN AND SANITARY SEWER PIPELINE.
4. 12" CLEARANCE BETWEEN THE OUTER SURFACE OF NEAR STRUCTURES SUCH AS CATCH BASINS, DRAIN INLETS, AND THE EDGE OF THE TRENCH IS REQUIRED.

MINIMUM PIPE SEPARATION REQUIREMENTS

REV. 01/29
05/14



Approved by:

Tammy Rudock

Tammy Rudock, General Manager

Joubin Pakpour, District Engineer, RCE
No. 59155

STD. NO.
MP-19

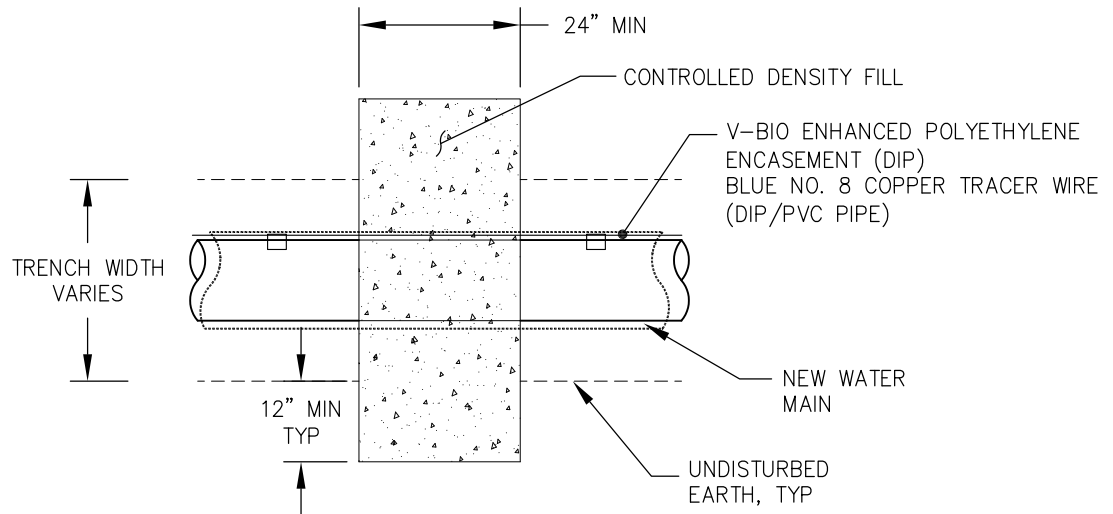

PLAN

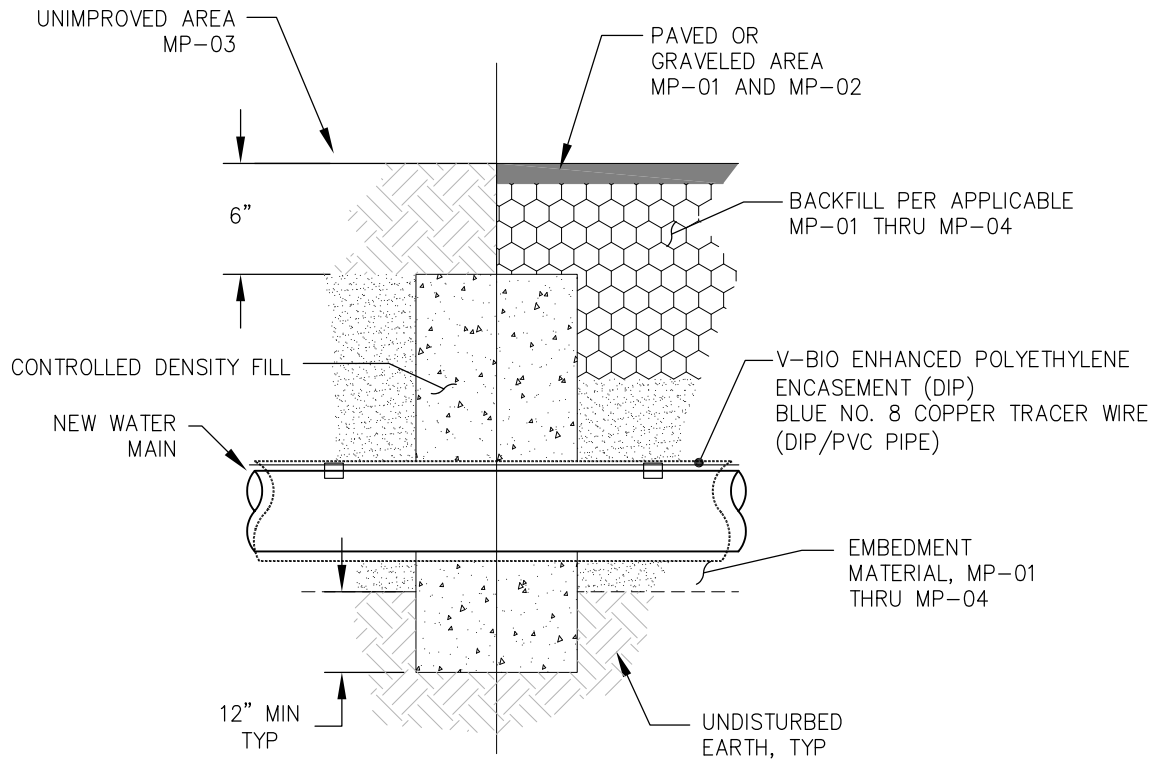

PROFILE

NOTES

1. TRENCH DAMS SHALL BE PLACED ON NEW WATER MAIN ALIGNMENTS WHERE SLOPES EXCEED 10% AT 100' INTERVALS OR AS DIRECTED BY THE DISTRICT.

TRENCH DAM

01/19
01/15
REV. 05/14



**MID-PENINSULA
WATER DISTRICT**

Approved by:

Tammy Rudock

Tammy Rudock, General Manager

Joubin Pakpour, District Engineer, RCE
No. 59155

**STD. NO.
MP-20**

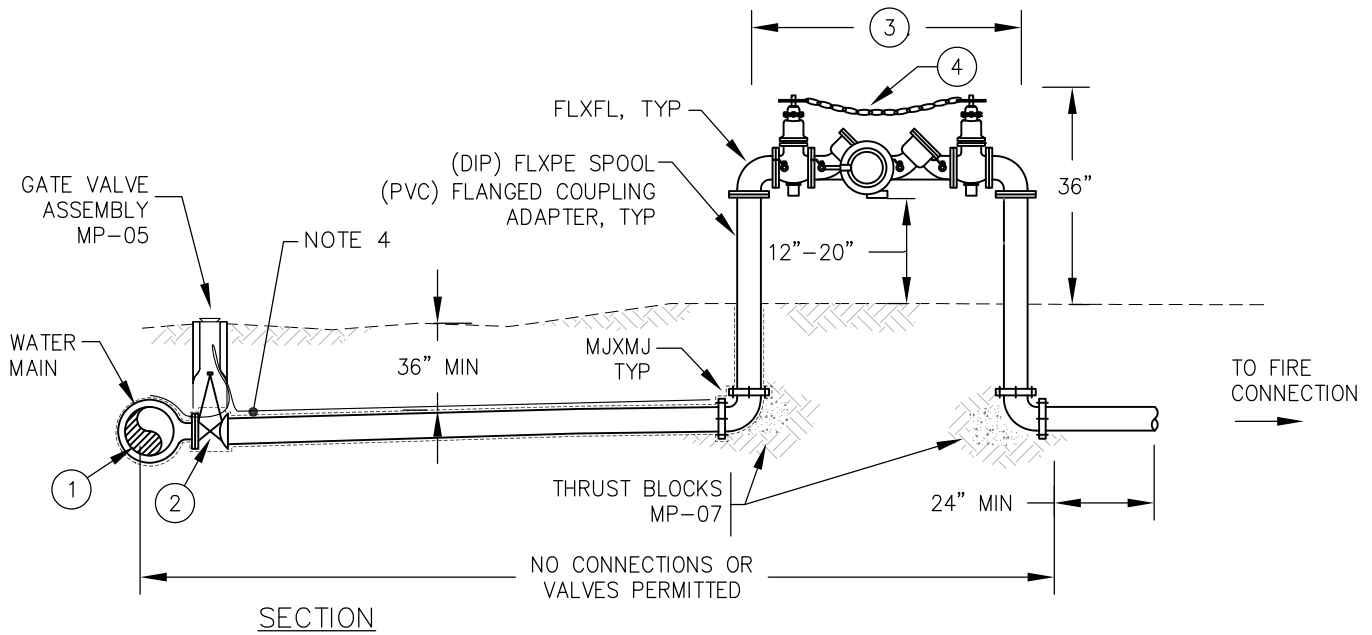

SECTION

REQUIREMENTS

1. REDUCE PRESSURE BACKFLOW ASSEMBLIES ARE REQUIRED ON ALL FIRE SERVICE CONNECTIONS.
2. FAILURE TO PROVIDE BACKFLOW PROTECTION WILL RESULT IN WATER SERVICE SHUTDOWN PER TITLE 17, SECTION 7583-7605 OF THE STATE OF CALIFORNIA CODE OF REGULATIONS. (TITLE 17, DIVISION I, CHAPTER 5, SUBCHAPTER 1, GROUP 4, ARTICLES 1 AND 2.)
3. ENCLOSURE USED FOR BACKFLOW ASSEMBLY SHALL BE APPROVED BY THE DISTRICT.
4. BACKFLOW ASSEMBLY SHALL BE TESTED AND CERTIFIED BY A SAN MATEO COUNTY'S CERTIFIED TESTER PRIOR TO BEING PUT IN SERVICE.
5. VERTICAL INSTALLATIONS ARE ALLOWED BUT REQUIRE DISTRICT APPROVAL PRIOR TO DESIGN AND INSTALLATION.
6. ALL FIRE SERVICES INSTALLED ON SERVICE LINES 4" DIA OR GREATER SHALL BE REDUCED PRESSURE DETECTOR ASSEMBLY (RPDA) STYLE.
7. FIRE DEPARTMENT CONNECTION (FDC) IF REQUIRED SHALL HAVE TWO 2-1/2" INLET WITH CLAPPERS AND WAFER CHECK VALVE, SHOULD FACE THE STREET AND BE LOCATED A MAX 5' BEHIND THE R/W. A 36" MIN CLEARANCE AROUND THE BACKFLOW AND FDC IS REQUIRED. ALL EXPOSED SURFACES OF THE FDC SHALL BE PAINTED RED. LOCATION OF THE CONNECTION SHALL BE DETERMINED BY THE FIRE DEPARTMENT.

NOTES

1. THE SIZE OF THE PIPING, TAPPING VALVE, DETECTOR CHECK AND BACKFLOW PREVENTER SHALL BE DETERMINED IN ACCORDANCE WITH FIRE SERVICE FLOW REQUIREMENTS.
2. FIRE SERVICE LOCATION SHALL BE DETERMINED BY DISTRICT.
3. BOLLARD REQUIRED PER MP-11. EXACT LOCATION TO BE DETERMINED BY DISTRICT
4. ENCASE DIP WITH V-BIO ENHANCED POLYETHYLENE ENCASEMENT. TAPE A BLUE NO.8 AWG, COPPER TRACER WIRE TO THE TOP OF PIPE.

LEGEND

- ① TEE (TYPE DETERMINED BY DISTRICT) OR TAPPING SLEEVE JMC 6432, AS DIRECTED BY THE DISTRICT
- ② GATE VALVE, FLXMJ, MUELLER NO. A-2362
- ③ APPROVED BY SAN MATEO COUNTY HEALTH SYSTEM REDUCED PRESSURE BACKFLOW ASSEMBLY WITH OS&Y VALVES.
- ④ 1/2" CHAIN AND LOCK WITH MINIMUM SLACK AND/OR TAMPER SWITCH AS DIRECTED BY THE FIRE DEPARTMENT.

**FIRE SERVICE CONNECTION
REQUIREMENTS (4" OR GREATER)**

REV. 04/21
01/19
01/15
05/14
05/02



Approved by: *Tammy Rudock*
 Tammy Rudock, General Manager
 Joubin Pakpour, District Engineer, RCE
 No. 59155

**STD. NO.
MP-21**

METER VAULT AND SERVICE CONNECTION MP-12 THRU MP-14

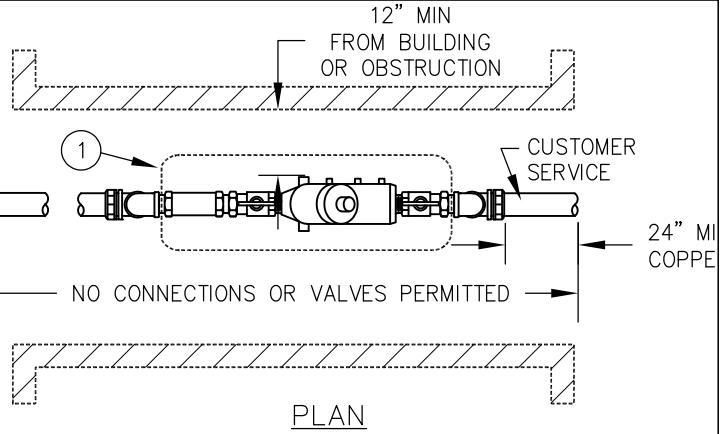

LEGEND

- ① REDUCED PRESSURE BACKFLOW PREVENTER WITH STRAINER AND LEAD FREE APPROVED BY SAN MATEO COUNTY HEALTH SYSTEM.
- ② BRASS 90° BENDS, MUELLER H-15531N.
- ③ TYPE K COPPER. COPPER PIPE SHALL HAVE BLUE SEAMLESS POLYETHYLENE COAT DISTRIBUTED BY MUELLER STREAMLINE CO.
- ④ MUELLER 110 COMPRESSION CONNECTION H-15526N.
- ⑤ FOR "5/8", 3/4" AND FOR 1" CUSTOMER SERVICE USE MUELLER 110 COMPRESSION CONNECTION H-15451N.FOR 1-1/2" AND 2" SERVICE USE BRASS METER FLANGE (LOW LEAD) WITH MUELLER 110 COMPRESSION CONNECTION H-15428N.
- ⑥ MUELLER 110 COMPRESSION CONNECTION H-15533N ON CUSTOMER SIDE IF APPLICABLE.
- ⑦ OPTIONAL PRESSURE REDUCING VALVE SHALL BE INSTALLED AND MAINTAINED BY CUSTOMER.

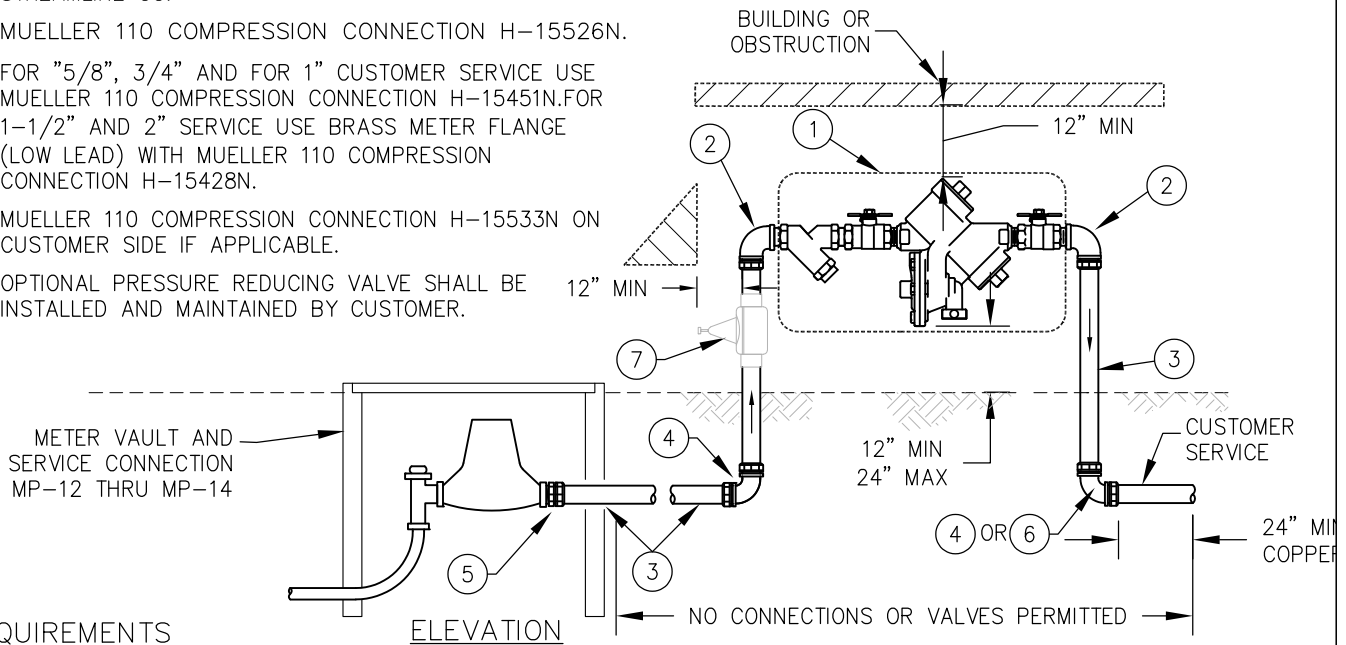

REQUIREMENTS

- 1. REDUCED PRESSURE BACKFLOW ASSEMBLIES ARE REQUIRED ON ALL SERVICE CONNECTIONS TO PROPERTIES THAT HAVE A SUPPLEMENTAL SOURCE OF WATER, A FIRE SPRINKLER SYSTEM, WELL, IRRIGATION SYSTEM THAT HAS AN AUTOMATIC CHEMICAL FEEDING CONTROL, PUMPS, MULTI STORY BUILDING OR ANY OTHER INSTANCE THAT MAY CONTAMINATE POTABLE WATER SUPPLY OR AS DIRECTED BY THE DISTRICT.
- 2. ALL REDUCED PRESSURE BACKFLOW ASSEMBLIES SHALL BE INSTALLED ON CUSTOMER PROPERTY ADJACENT TO THE METER.
- 3. FAILURE TO PROVIDE REDUCED PRESSURE BACKFLOW PROTECTION WILL RESULT IN WATER SERVICE SHUTDOWN PER TITLE 17, SECTION 7583-7605 OF THE STATE OF CALIFORNIA CODE OF REGULATIONS (TITLE 17, DIVISION 1, CHAPTER 5, SUB-CHAPTER 1, GROUP 4, ARTICLES 1 AND 2).
- 4. ENCLOSURE USED FOR BACKFLOW ASSEMBLY SHALL BE APPROVED BY THE DISTRICT.
- 5. BACKFLOW ASSEMBLY SHALL BE TESTED AND CERTIFIED BY A SAN MATEO COUNTY'S CERTIFIED TESTER PRIOR TO BEING PUT IN SERVICE.
- 6. VERTICAL INSTALLATIONS ARE ALLOWED BUT REQUIRE DISTRICT APPROVAL PRIOR TO DESIGN AND INSTALLATION.
- 7. PRE-APPROVAL BY THE DISTRICT IS REQUIRED FOR ANY PRESSURE SYSTEM INSTALLATION.

**REDUCED PRESSURE BACKFLOW
PREVENTER ASSEMBLY (RESIDENTIAL)**

REV. 04/21
01/19
05/14
05/02



Approved by:

Tammy Rudock

Tammy Rudock, General Manager

Joubin Pakpour, District Engineer, RCE
No. 59155

**STD. NO.
MP-22**

CAST-IRON COVER
MARKED "ANODE"

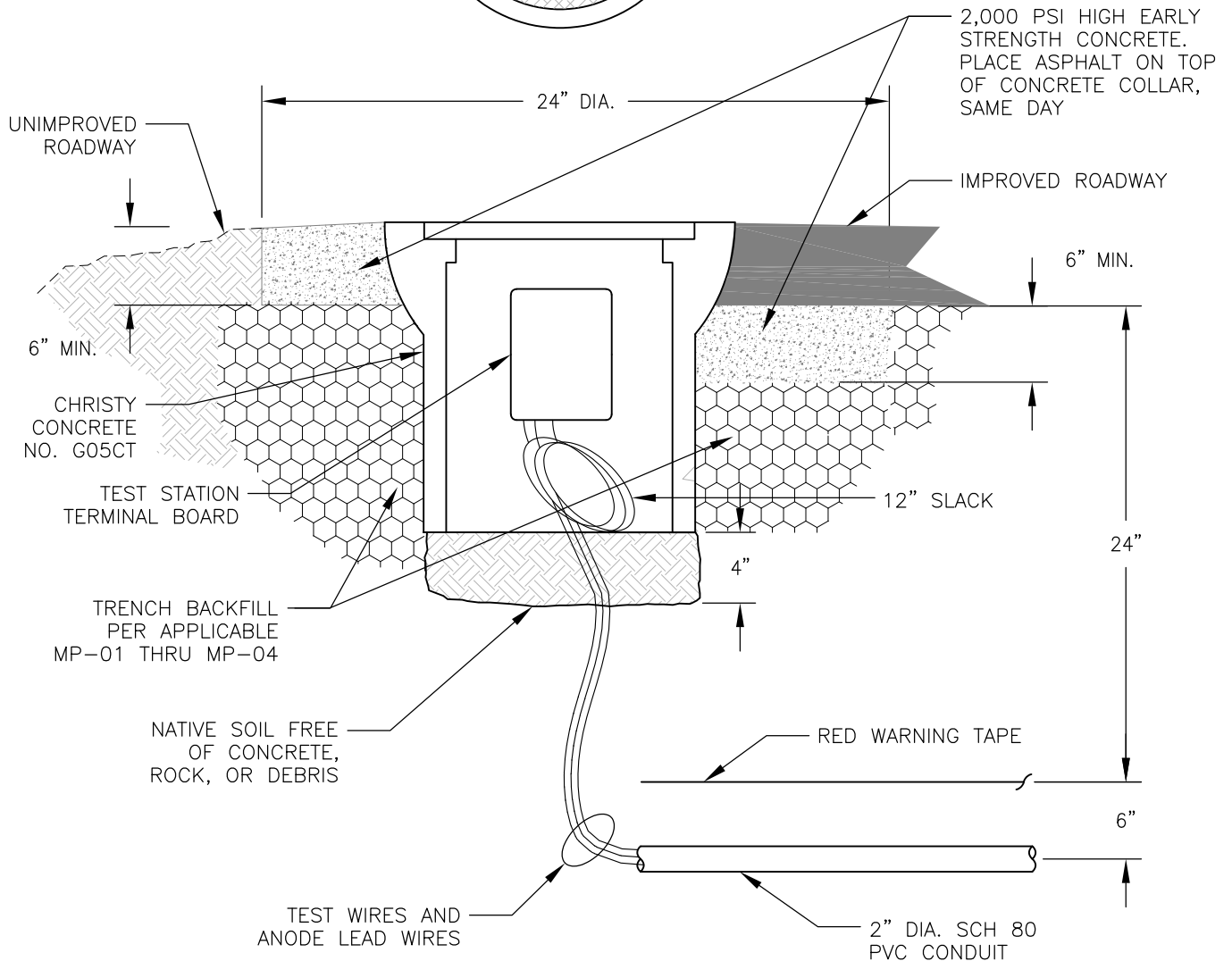
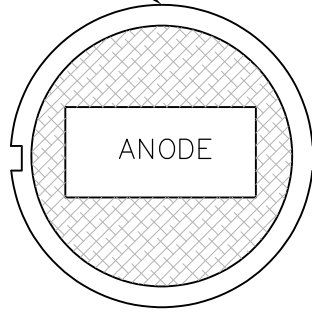

FLUSH-MOUNTED TEST STATION BOX

REV. 04/21



**MID-PENINSULA
WATER DISTRICT**

Approved by:

Tammy Rudock, General Manager

Joubin Pakpour, District Engineer, RCE
No. 59155

**STD. NO.
MP-23**

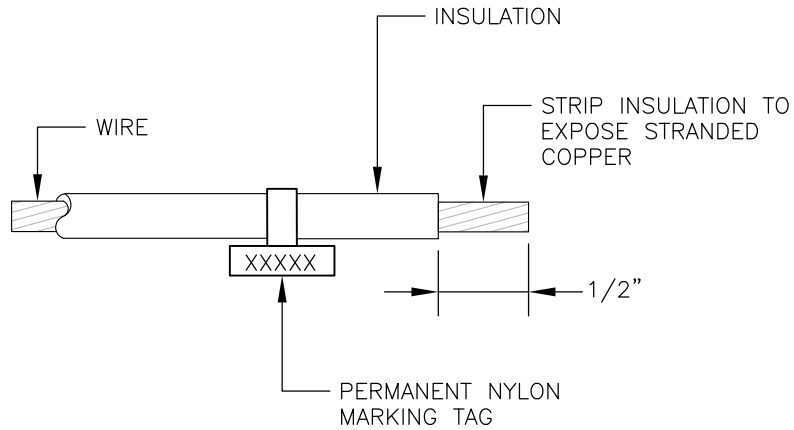

WIRE IDENTIFIER SCHEDULE	
ANODE	ANODE
PROTECTED DIP	DIP (PR)
UNPROTECTED DIP/CIP	DIP/CIP (UPR)
CROSS	CROSS
TEE	TEE
90° ELBOW	90° EL
45° ELBOW	45° EL
GATE VALVE	GV
BLOW OFF	BO
FIRE HYDRANT	FH

WIRE IDENTIFIER

REV. 04/21



Approved by

Tammy Rudock

Tammy Rudock, General Manager

Joubin Pakpour, District Engineer, RCE
No. 59155

STD. NO.
MP-24

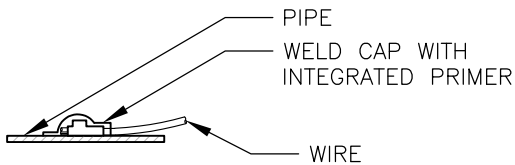
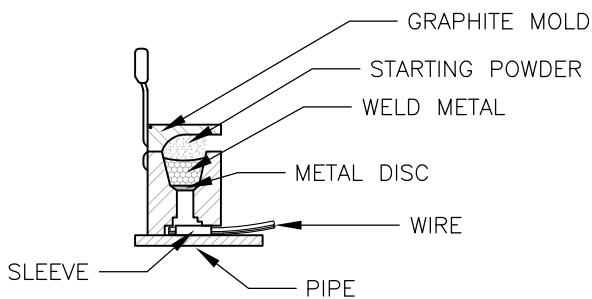
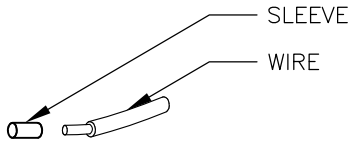
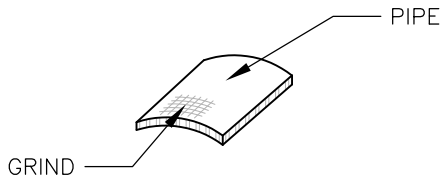

1. ALL WELDS SHALL BE 6" APART AT MINIMUM.
2. GRIND PIPE TO BARE METAL AND CLEAN SURFACE. GROUND AREA SHALL BE LARGE ENOUGH FOR EXOTHERMIC WELD AND SMALL ENOUGH TO BE COMPLETELY COVERED BY WELD CAP.
3. STRIP INSULATION FROM WIRE AND ATTACH SLEEVE.
4. HOLD MOLD FIRMLY WITH OPENING AWAY FROM OPERATOR. IGNITE WITH FLINT GUN. REMOVE SLAG FROM CONNECTION WITH CHIPPING HAMMER. TEST WELD WITH 22 OZ HAMMER.
5. COVER WITH WELD CAP WITH INTEGRATED PRIMER. REPAIR ALL DAMAGE TO COATING BEYOND WELD IN ACCORDANCE WITH COATING AND LINING MFG RECOMMENDATIONS.

NOTES

PIN BRAZING SHALL BE ALLOWED UPON DISTRICT APPROVAL.

EXOTHERMIC WELD

REV. 04/21



Approved by:

Tammy Rudock

Tammy Rudock, General Manager

Joubin Pakpour, District Engineer, RCE
No. 59155

STD. NO.
MP-25

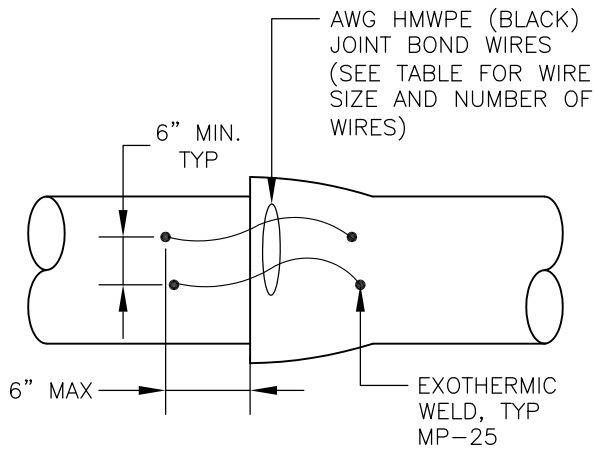

PUSH-ON JOINT

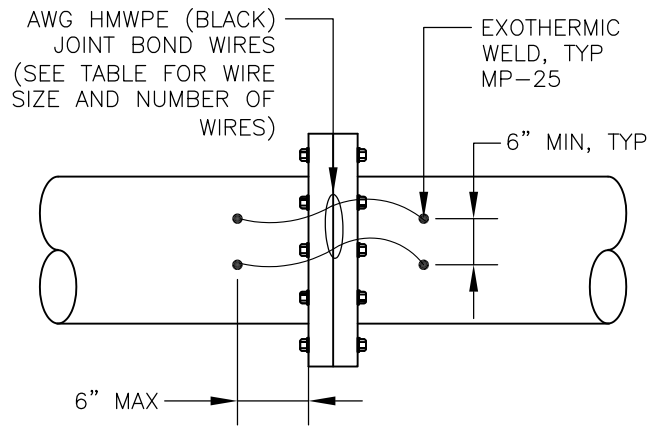

FLANGED JOINT

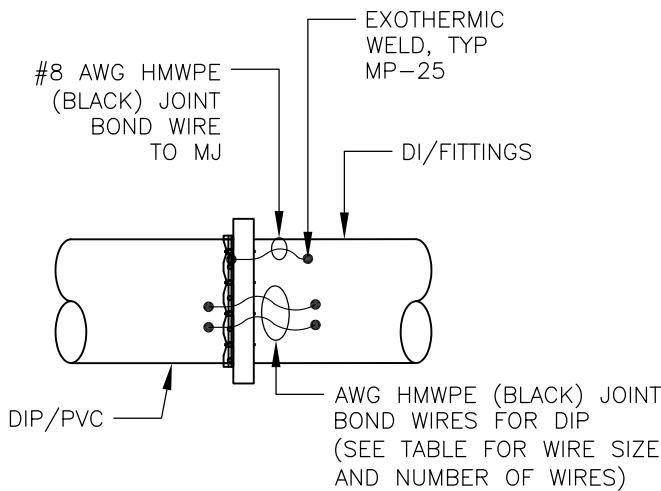

MECHANICAL JOINT

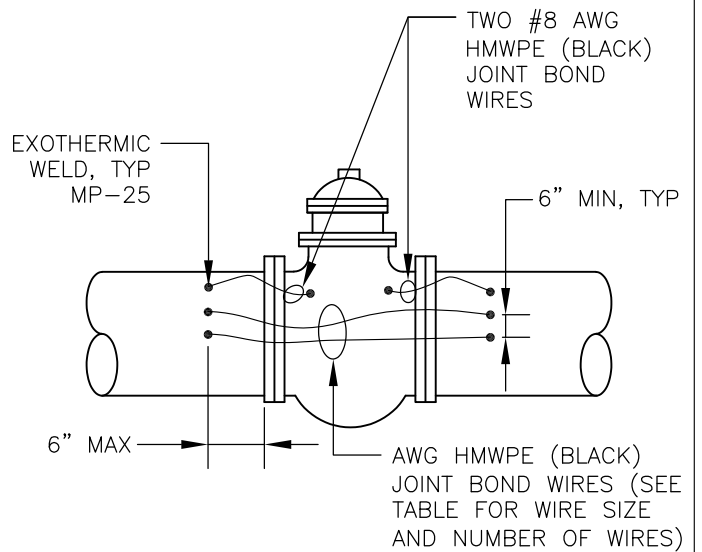

VALVE

PIPE DIAMETER	6"	8"	10"	12"	18"	24"
WIRE SIZE*	#4	#4	#4	#2	#2	#2
NUMBER OF WIRES	2	2	2	2	3	4

*WIRE SIZES ARE SHOWN FOR CLASS 50 DIP

PIPE JOINT BONDING

REV. 04/21



**MID-PENINSULA
WATER DISTRICT**

Approved by

Tammy Rudock

Tammy Rudock, General Manager

Joubin Pakpour, District Engineer, RCE
No. 59155

**STD. NO.
MP-26**

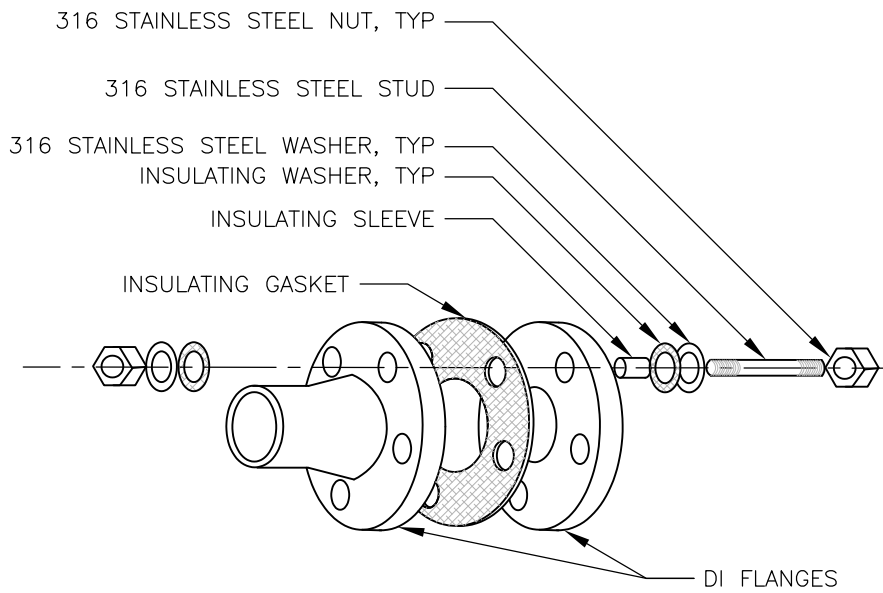
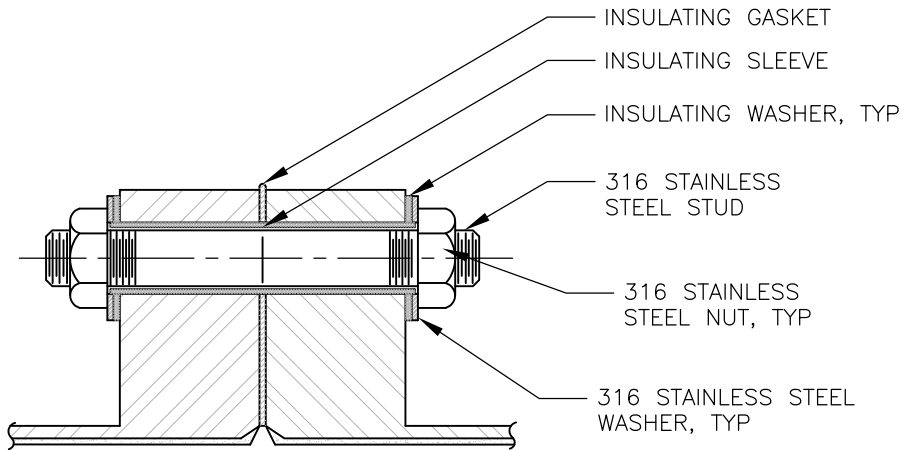

ABOVE GROUND INSULATING FLANGE ASSEMBLY

REV. 04/21



**MID-PENINSULA
 WATER DISTRICT**

Approved by:

Tammy Rudock, General Manager

Joubin Pakpour, District Engineer, RCE
 No. 59155

**STD. NO.
 MP-27**

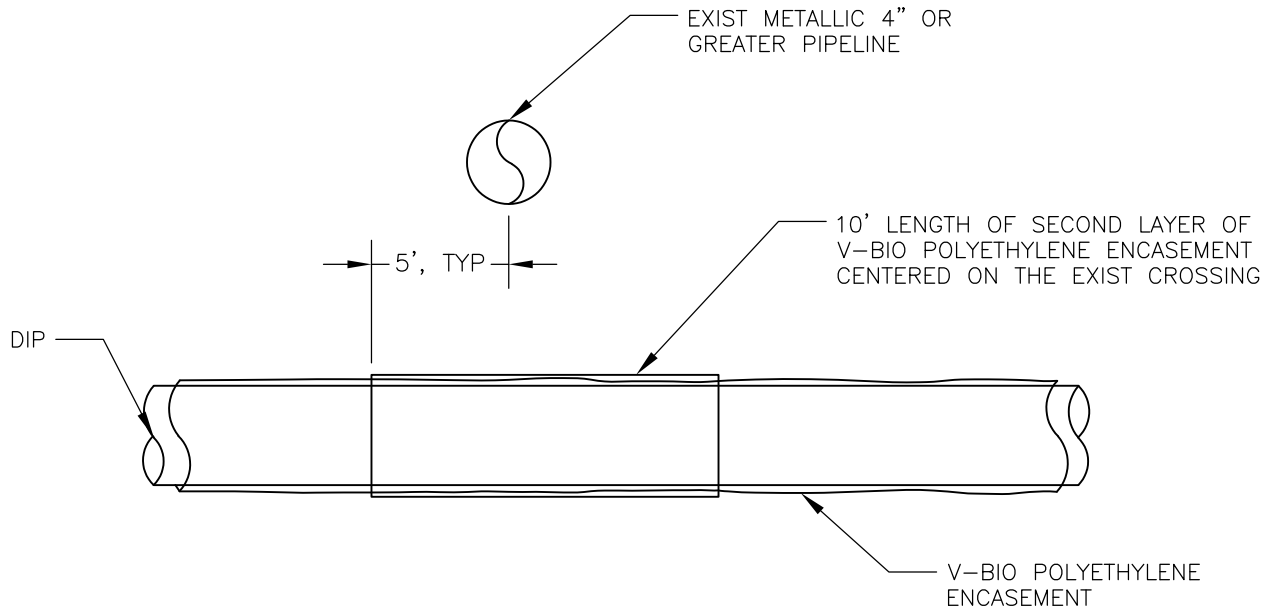

DOUBLE ENCASEMENT

REV. 04/21



**MID-PENINSULA
WATER DISTRICT**

Approved by

Tammy Rudock, General Manager

Joubin Pakpour, District Engineer, RCE
No. 59155

**STD. NO.
MP-28**

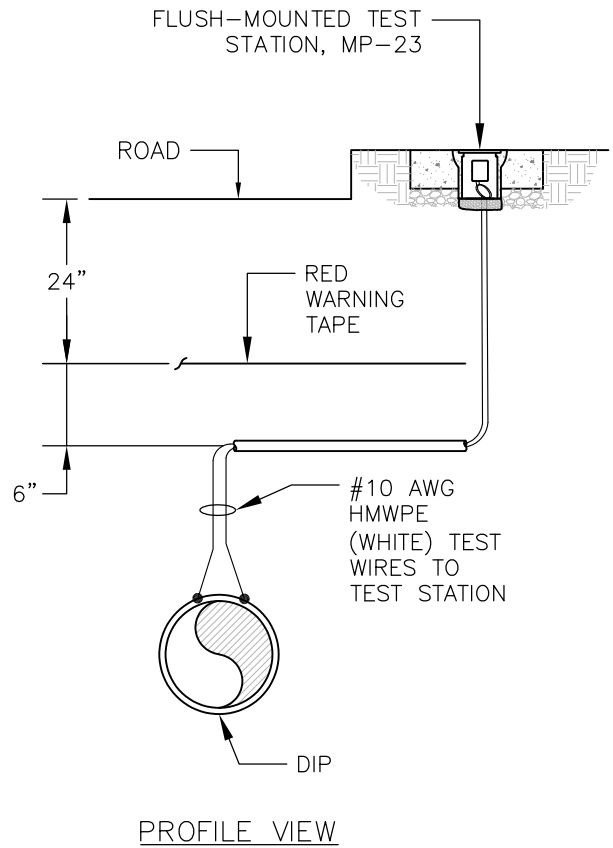
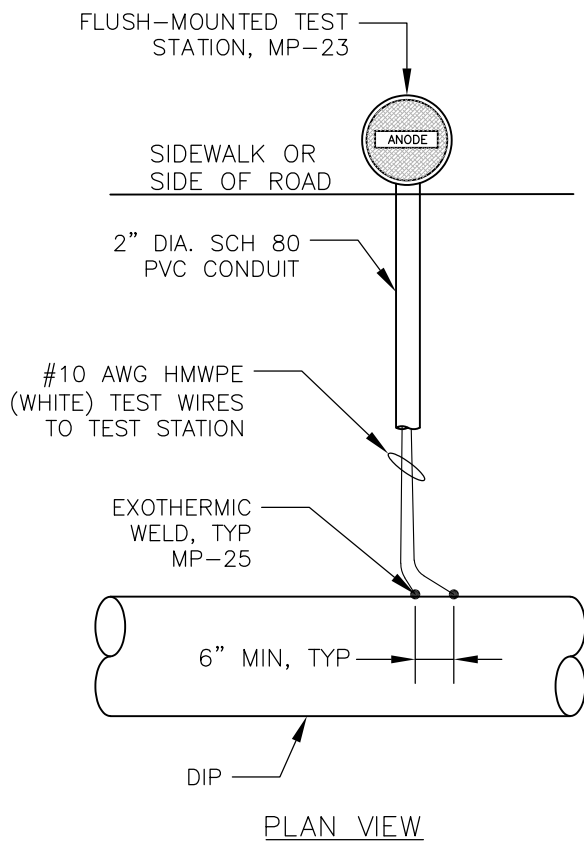
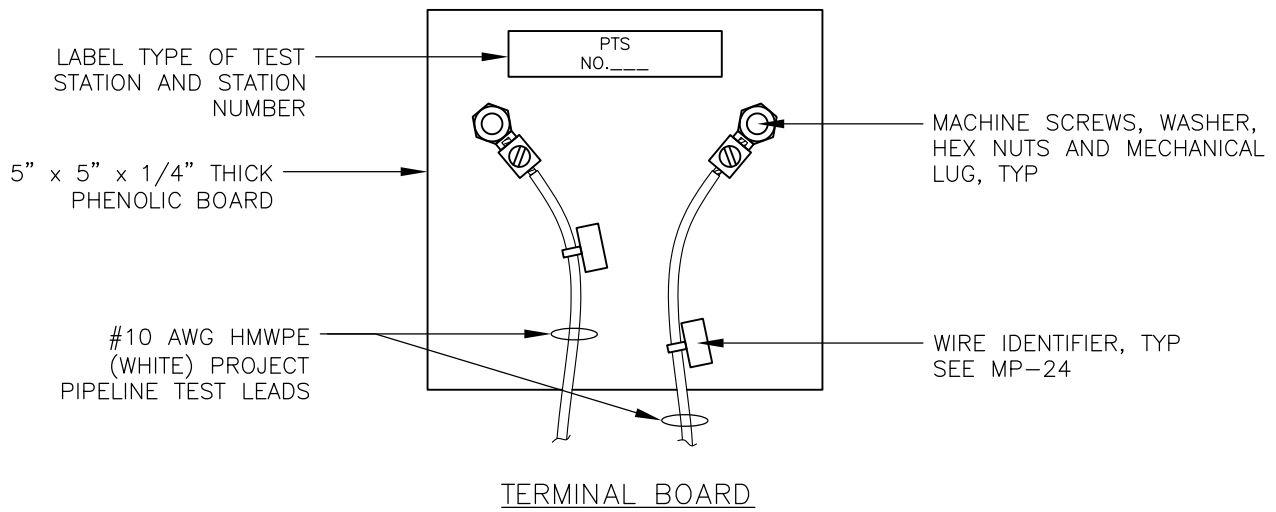

POTENTIAL TEST STATION (PTS)

REV. 04/21



**MID-PENINSULA
WATER DISTRICT**

Approved by:

Tammy Rudock

Tammy Rudock, General Manager

Joubin Pakpour, District Engineer, RCE
No. 59155

**STD. NO.
MP-29**

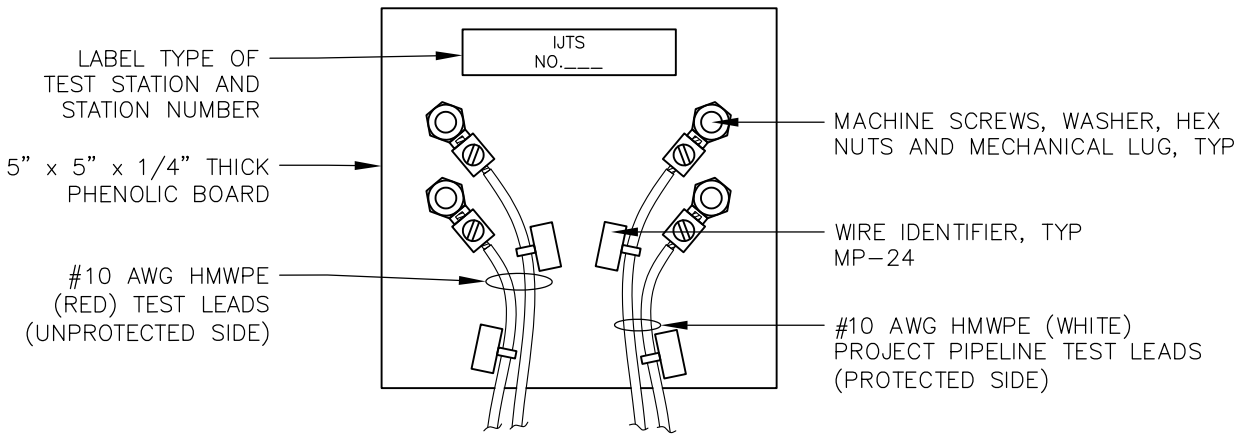

TERMINAL BOARD

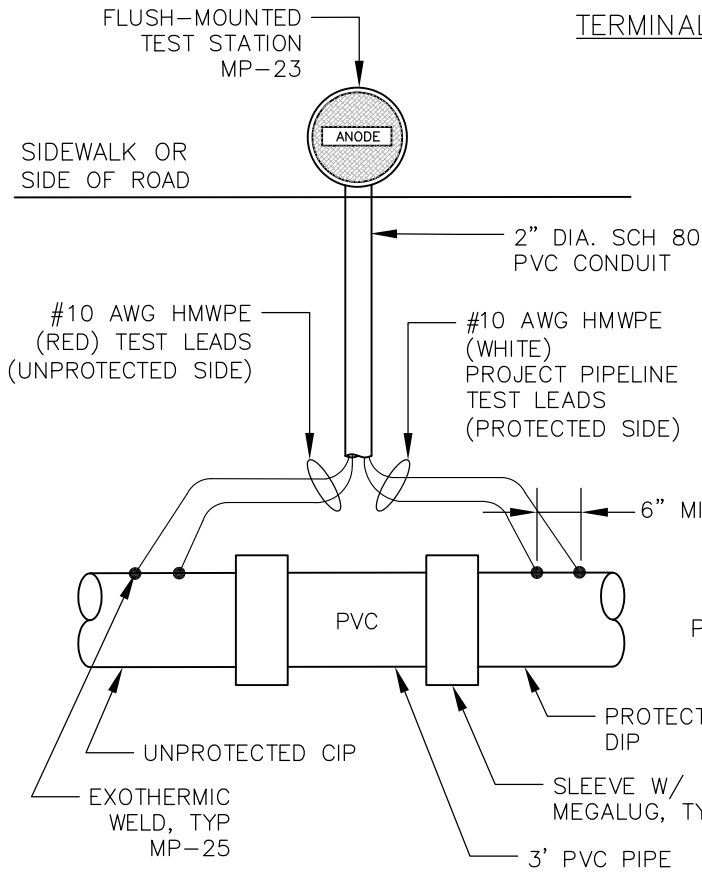

PLAN VIEW

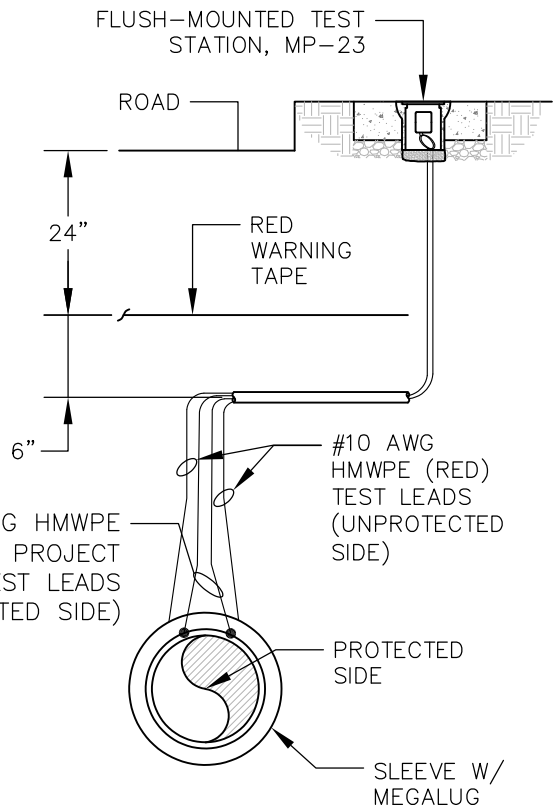

PROFILE VIEW

INSULATING JOINT TEST STATION (IJTS) AT CIP TIE-INS

REV. 04/21



Approved by:

Tammy Rudock, General Manager

Joubin Pakpour, District Engineer, RCE
No. 59155

**STD. NO.
MP-30**

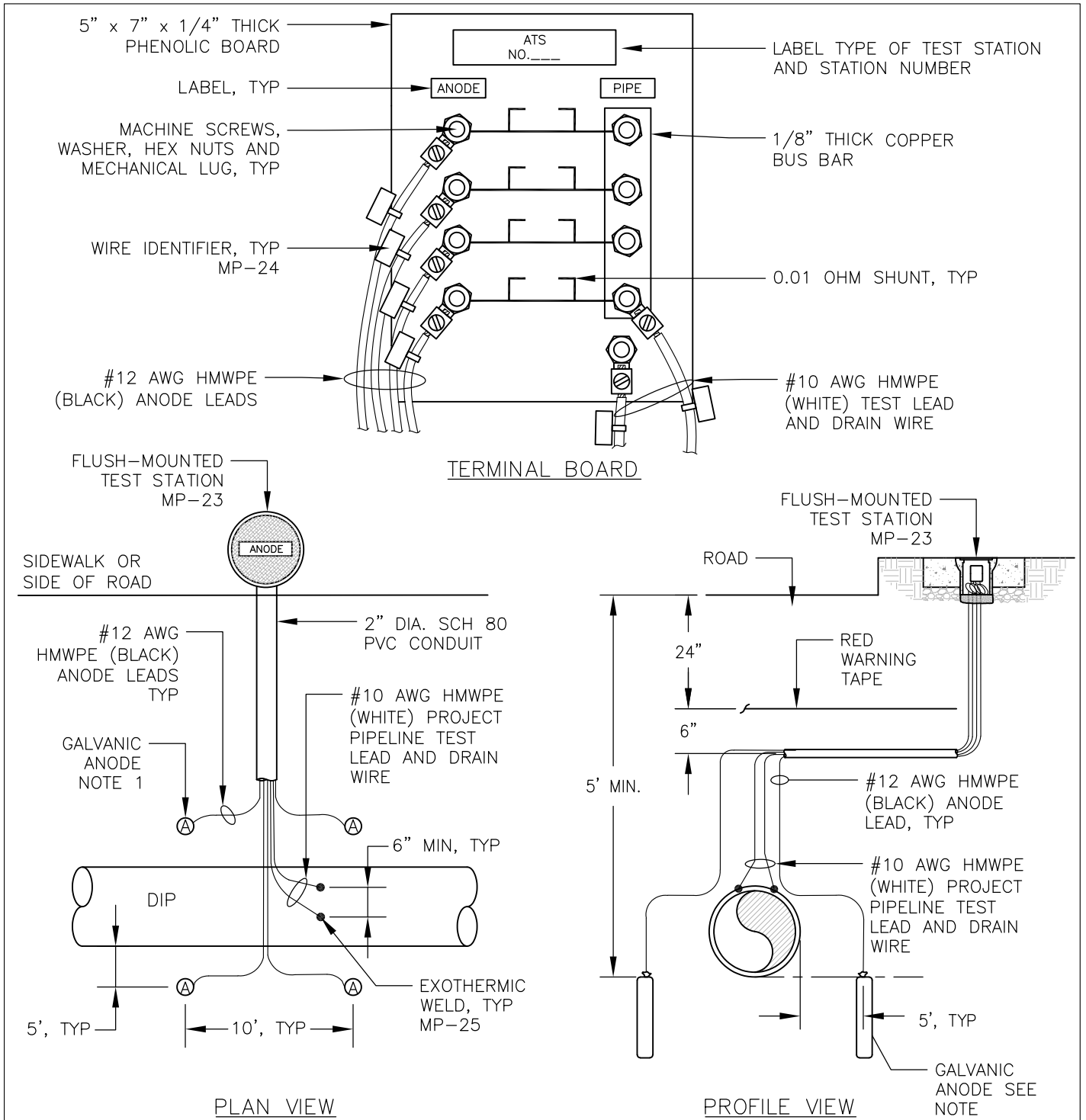

NOTES

1. NUMBER AND TYPE OF ANODES WILL BE DETERMINED BY THE DISTRICT.

ANODE TEST STATION (ATS)

REV. 04/21



Approved by:
Tammy Rudock
 Tammy Rudock, General Manager
 Joubin Pakpour, District Engineer, RCE
 No. 59155

**STD. NO.
 MP-31**

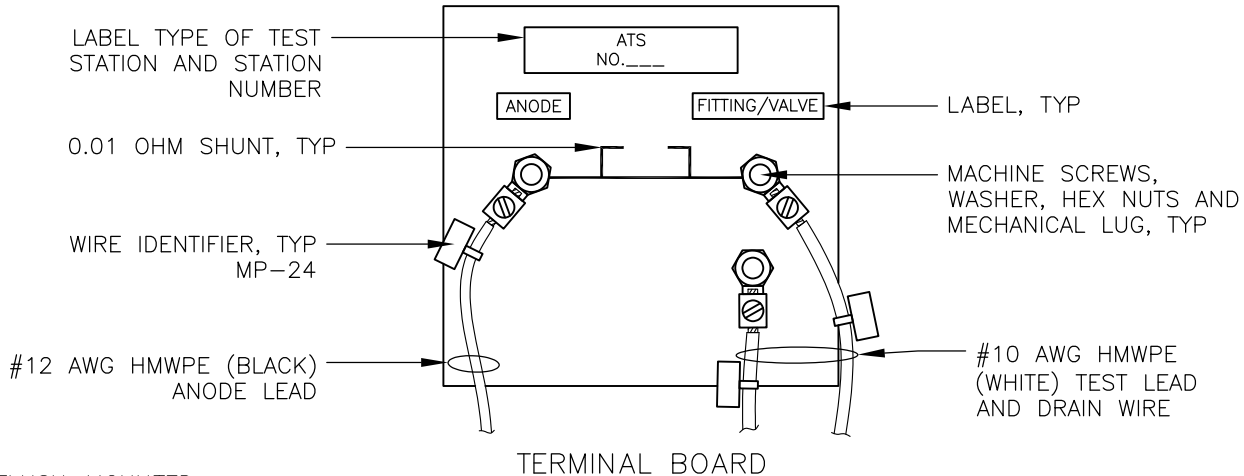

TERMINAL BOARD

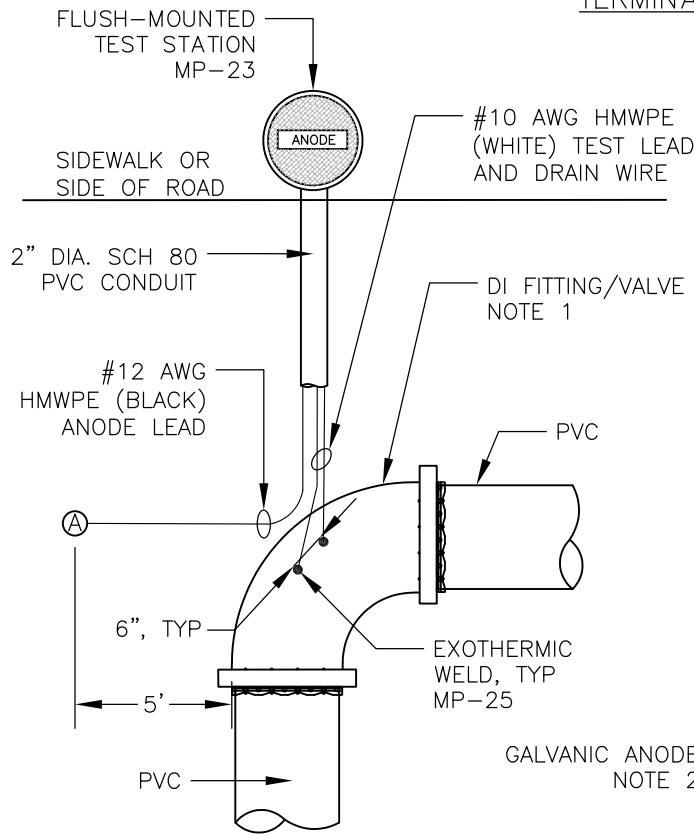

PLAN VIEW

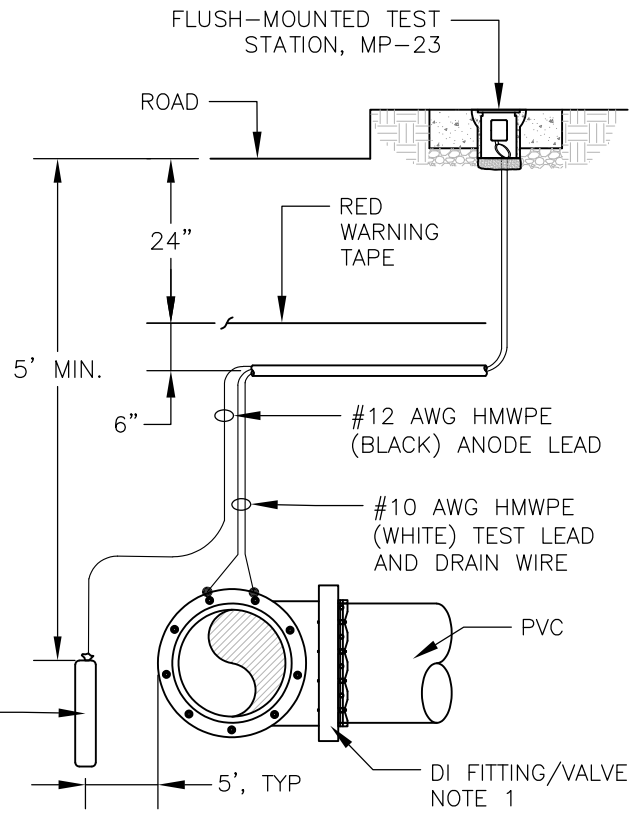

PROFILE VIEW

NOTES

1. DUCTILE IRON FITTING/VALVE MAY BE DIFFERENT GEOMETRY, SUCH AS TEE OR INLINE.
2. TYPE OF ANODE WILL BE DETERMINED BY THE DISTRICT.

ANODE TEST STATION (ATS) DI FITTING/VALVE WITH PVC PIPE

REV. 04/21



Approved by:

 Tammy Rudock, General Manager
 Joubin Pakpour, District Engineer, RCE
 No. 59155

**STD. NO.
MP-32**