

**CB 4000**



**Warning**

**Forward this manual to the person responsible for Installation, Operation and Maintenance of the product described herein. Without access to this information, faulty Installation, Operation or Maintenance may result in personal injury or equipment damage.**

# Installation, Operation and Maintenance of Airflex CBElement Assemblies



**Caution:**



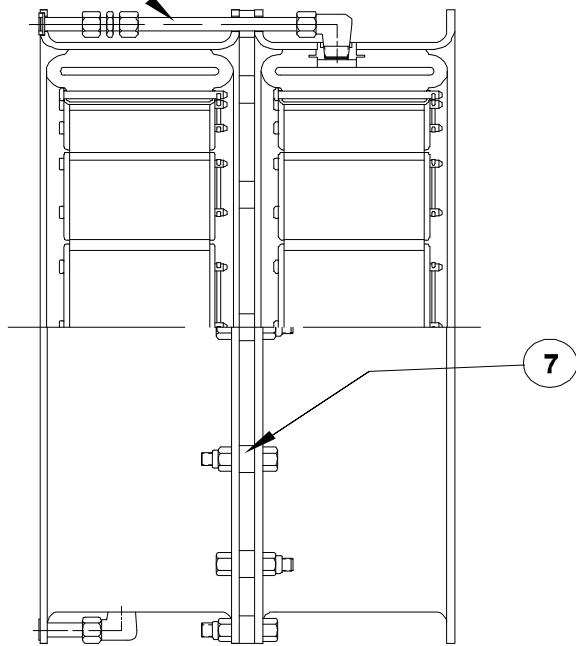
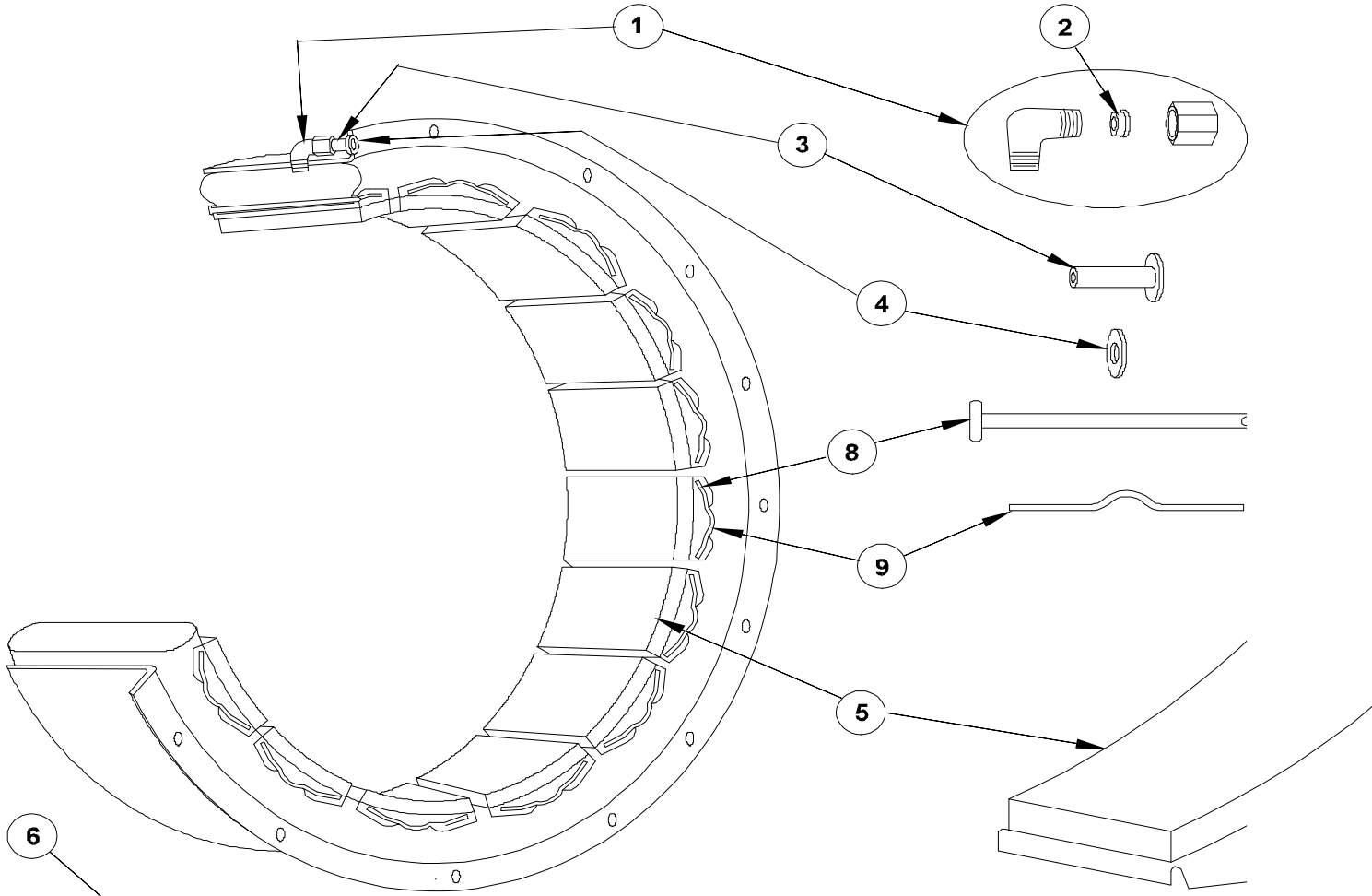
**Use Only Genuine Airflex Replacement Parts**

Danfoss recommends the use of genuine Airflex replacement parts. The use of non-genuine Airflex replacement parts could result in substandard product performance, and may void your Danfoss warranty.

# Table of Contents

<b>1.0</b>	<b>INTRODUCTION</b>	<b>2</b>
1.1	Description .	2
1.2	How it Works .	2
<b>2.0</b>	<b>INSTALLATION</b>	<b>3</b>
2.1	Mounting Arrangements .	3
2.2	Mounting Consideration .	5
2.3	Mounting Spider and Drum Hub .	6
2.4	Shaft Alignment .	6
2.5	Hydraulic Actuation Systems .	7
2.6	Air Control System .	7
<b>3.0</b>	<b>OPERATION</b>	<b>8</b>
3.1	Torque, RPM and Pressure Limits .	8
<b>4.0</b>	<b>MAINTENANCE</b>	<b>9</b>
4.1	Periodic Inspection .	9
4.2	Removal of Element Assembly and Drum (Single and Dual)	10
4.3	Disassembly of the Dual Element .	10
4.4	Removal of Spider and Drum Hub .	11
4.5	Friction Shoe Replacement .	11
<b>5.0</b>	<b>SPARE PARTS STORAGE</b>	<b>11</b>
5.1	Element Assemblies .	11
5.2	Drums .	11
<b>6.0</b>	<b>ORDERING INFORMATION</b>	<b>11</b>
6.1	Product Nameplate .	11
6.2	Element Description/Identification .	11
<b>7.0</b>	<b>PARTS LISTS</b>	<b>13</b>
7.1	Single Element Assemblies .	13
7.2	Dual Element Assemblies .	19
<b>8.0</b>	<b>REPAIR KITS</b>	<b>20</b>
8.1	Friction Shoe, Shoe Pin and Lockwire Kits	20

**FIG.1 -COMPONENT PARTS FOR AIRFLEX  
TYPE CB ELEMENT**



DUAL MOUNTED

ITEM	DESCRIPTION
1	Elbow Assembly
1A	Optional-Quick Release Valve Assembly
1B	Optional-Quick Release Valve Muffler
2	Compression Ring
3	Air Connection Tube
4	Air Connection Gasket
5	Friction Shoe Assembly
6	AirTubeGroup(DualMounted)
7	Spacer Group (Dual Mounted)
8	Shoe Pin
9	Lockwire
58, &9	Friction Shoe Replacement Kit

## 1.0 INTRODUCTION

Throughout this manual, there are a number of **HAZARD WARNINGS** that must be read and adhered to in order to prevent possible personal injury and/or damage to equipment. Three signal words “**DANGER**”, “**WARNING**”, and “**CAUTION**” are used to indicate these - variety of hazard and are preceded by the safety alert symbol



**DANGER** - Denotes the most serious hazard and is used when serious injury or death **WILL** result from misuse or failure to follow specific instructions.



**WARNING** - Used when serious injury or death **MAY** result from misuse or failure to follow specific instructions.



**CAUTION** - Used when injury or product/equipment damage may result from misuse or failure to follow specific instructions. It is the responsibility and duty of all personnel involved in the installation, operation and maintenance of the equipment on which this device is used to fully understand the **DANGER**, **WARNING**, and **CAUTION** procedures by which hazards are to be avoided.

### 1.1 Description

1.1.2 The Airflex air-actuated CB element assembly is designed and manufactured to provide dependable clutch or brake service in a multitude of industrial applications. It is suited to high speed, cyclic operations, as well as for coupling and general power transmission. All torque load is carried through the neoprene and cord actuating tube which absorbs damaging shock loads. The Airflex CB element assembly requires no lubrication or adjustment.

1.1.3 Airflex element assemblies are available for drum diameters from four inches through 45 inches. The element size designation indicate the nominal outside drum diameter in inches, the clutch model, and the width of the friction material. For example, size “12CB350” indicates the element operates on a drum having a nominal diameter of 12 inches, is an Airflex” CB” series clutch or brake (the scope of this manual) and has friction material which is three and one-half inches wide.

1.1.4 Where diametral space is limited, or the torque required is greater than a single element can transmit, CB elements size 12CB350 and larger can be supplied as dual units.

### 1.2 How It Works

1.2.1 Referring to Figure 1, CB construction consists of a neoprene and cord actuating tube which is bonded to the outer steel rim. The rim is drilled for mounting to the driving component (or reaction bracket in the case of a CB brake application). Friction shoe assemblies (FSA's) are attached to the inside diameter of the tube with shoe pins which are then retained with lockwires.

1.2.2 As air pressure is applied to the air actuating tube, the tube inflates, forcing the friction shoe assemblies uniformly against the drum which is attached to the driven component. In the case where the CB element is being used as a clutch and is attached to the driving shaft, through the element mounting component (typically an iron spider), through the rim/tube structure to the friction shoe assemblies, where the torque is transmitted through the friction couple to the components mounted on the driven shaft (clutch drum and drum mounting component). As actuating air is exhausted, the resiliency of the tube, aided by centrifugal force when used as a clutch, retracts the shoes, resulting in total disengagement.

### 1.3 Element Adjustment

1.3.1 Airflex CB elements are completely self adjusting and automatically compensate for lining and drum wear. Lubrication is not required. The torque developed is dependent upon rotating speed and applied air pressure. By limiting the applied pressure, the element will act as a torque limiting device and provide overload protection.

1.3.2 To accomplish regulated or cushioned engagement of the element, a flow control valve may be installed in the element air supply line and adjusted to restrict air flow to the element while allowing free flow away from the element for rapid disengagement. By adjusting the flow, the rate of engagement may be varied. Note that the flow control valve does not regulate air pressure - the supply pressure must always be adequate to transmit the maximum required torque. Refer to the OPERATION section of this manual for air piping configurations.

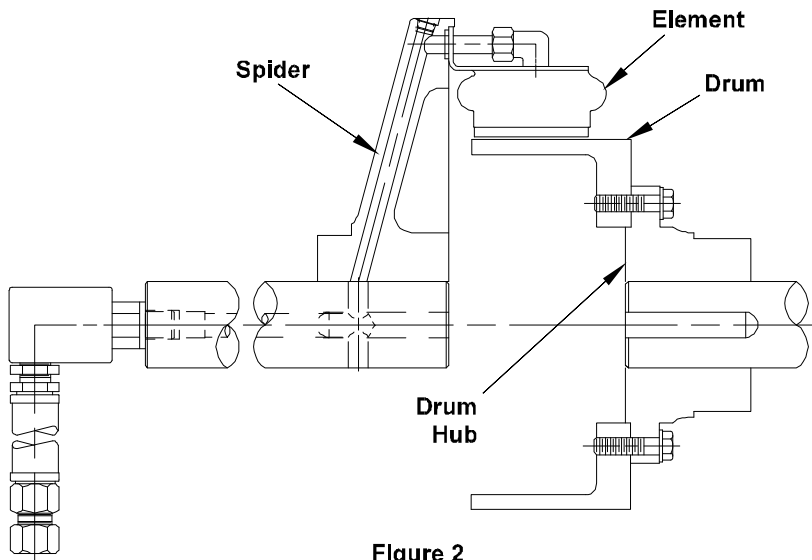


Figure 2

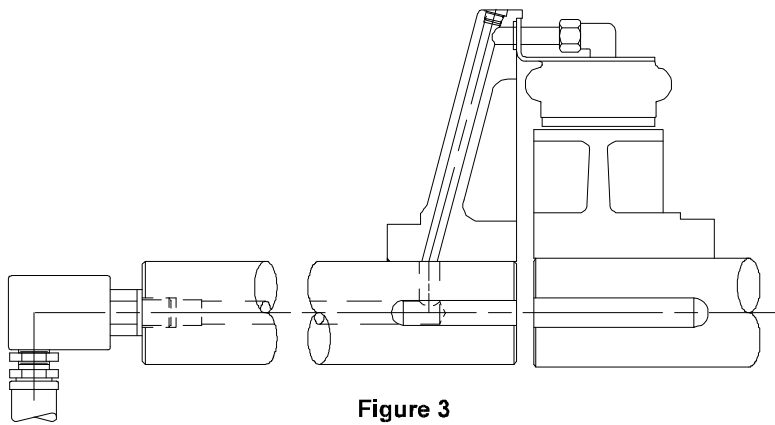


Figure 3

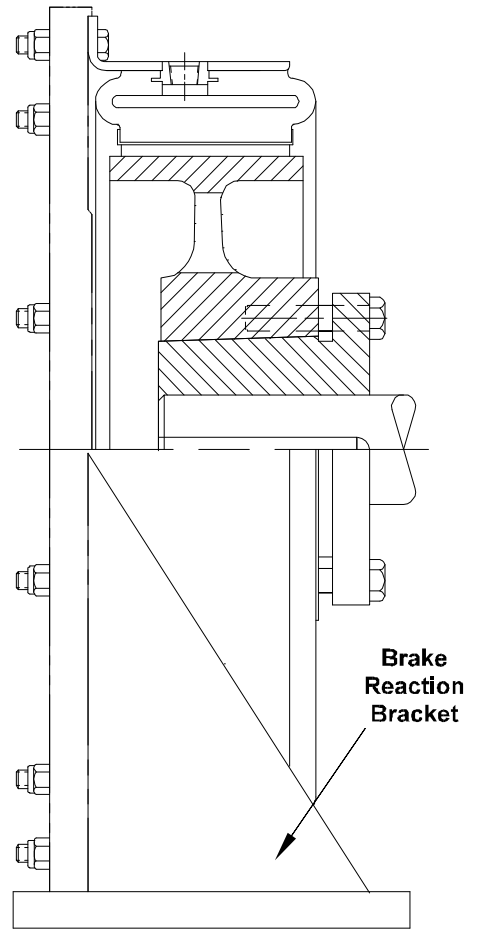


Figure 4

## 2.0 INSTALLATION

### **Warning:**

**Only qualified personnel should install, adjust or repair these units. Faulty workmanship will result in exposure to hazardous conditions or personal injury.**

### **Caution:**

**Do not inflate the element without having a drum in place. Inflation of the element without a drum in place will result in permanent damage to the element components.**

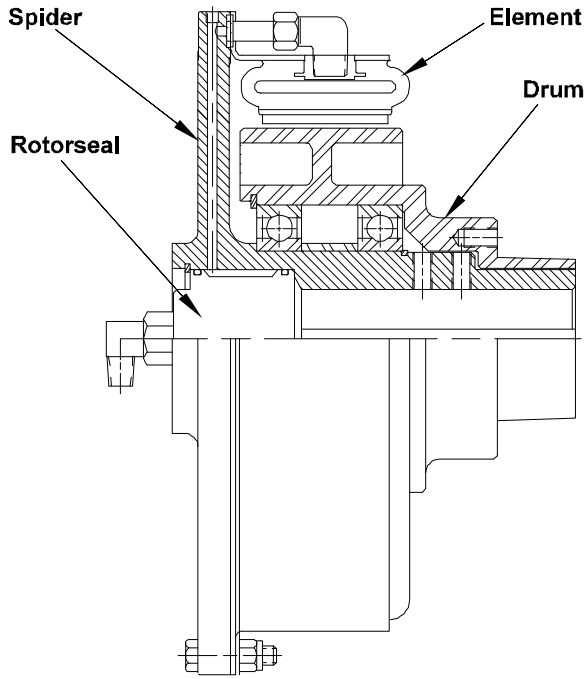
## 2.1 Mounting Arrangements

2.1.1 Figure 2 illustrates the gap-mounted arrangement. In this arrangement, the element is attached to a spider which is typically mounted on the driving shaft. The drum is attached to a drum hub which is typically mounted on the driven shaft. The gap between the two shafts allows the element and drum to be removed without disturbing either shaft.

Note: The text in the Installation, Alignment and Removal sections refer to this type of mounting arrangement.

2.1.2 Close-mounted arrangements may be used when shaft-to-shaft clearance is limited as illustrated in Figure 3.

2.1.3 Figure 4 illustrates a typical CB brake application. The drum and drum hub are attached to



**Figure 5**

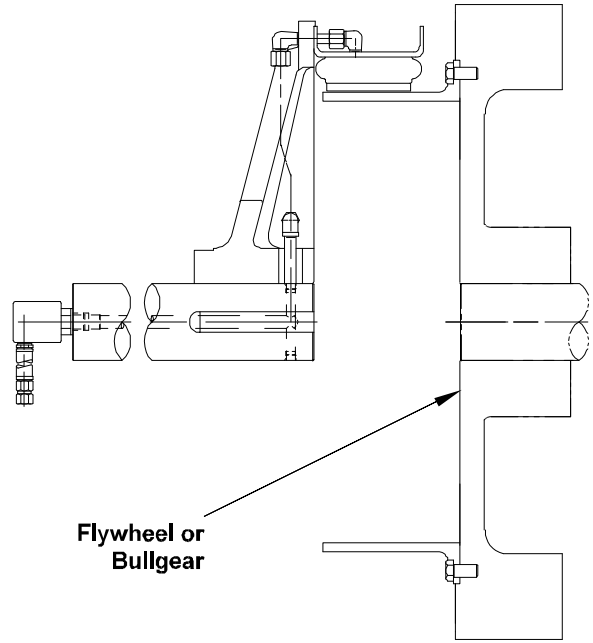
the shaft which is to be stopped. The element is attached to a rigid reaction bracket or the machine frame.

2.1.4 Airflex offers several economical packaged applications utilizing CB elements. Figure 5 illustrates an Airflex sheave clutch, incorporating a built in rotor seal and sealed ball bearings. A wide range of sheave sizes can be used with this type of package.

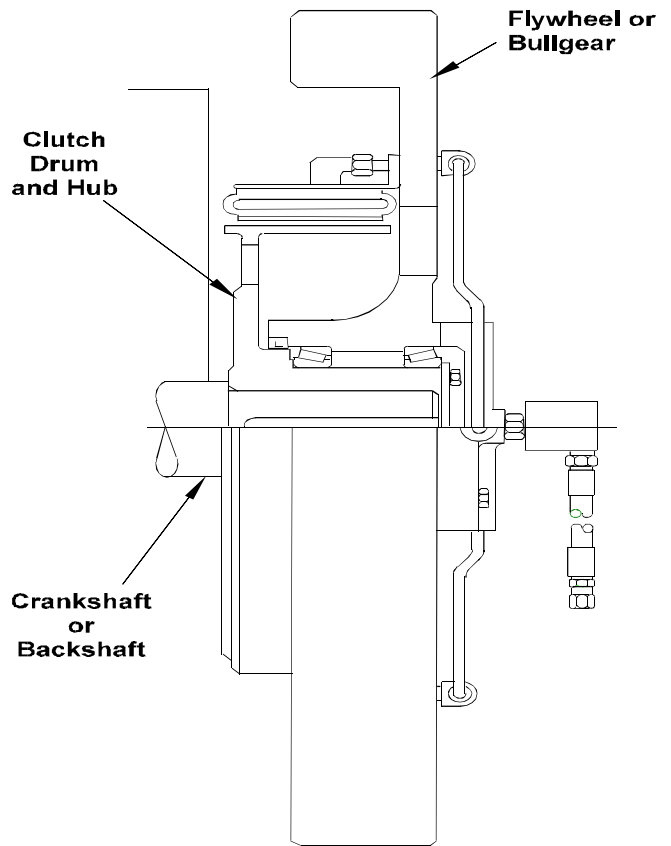
2.1.5 Figure 6 illustrates a typical engine-mounted application, where the clutch element is attached to a spider and the drum is attached to a shaft-mounted fly wheel or bull gear. This type of application is typically used when drilling of the air passage in the driving shaft is neither possible nor practical.

2.1.6 Figure 7 illustrates a CB clutch mounting for punch press applications. The drum and drum hub are attached to the crankshaft or back-shaft and the element is attached to a bearing-mounted fly wheel or bull gear. CB clutches on punch presses are typically used in combination with Airflex type CTE or CS brakes.

2.1.7 Airflex can provide specific drawings covering the different mounting arrangements mentioned. The maintenance of the element as assembly, tolerances and wear limits of friction material, and alignments specifications in this manual apply to all CB applications.



**Figure 6**



**Fig.7**

## 2.2 Mounting Considerations

2.2.1 The element must be protected from contamination by oil, grease or excessive amount of dust.



### Caution:

Oil or grease contamination will result in a reduction of developed clutch or brake torque. Either of these conditions will result in clutch or brake slippage and overheating.



### Caution:

All rotating equipment must be guarded to comply with applicable safety standards.

2.2.2 For clutch and brake applications, shaft alignment must be within the tolerances indicated in the Alignments section of this manual.



### Caution:

Operation with shaft misalignment exceeding the limits indicated in the Alignment section of this manual will result in accelerated wear of the element components. Severe misalignment will result in excessive vibration and/or overheating when disengaged due to dragging of the friction shoes.

2.2.3 All mounting fasteners must be of the proper size and grade, and torqued to the appropriate value. See Table 1.

**TABLE 1 - FASTENER SIZE & ASSEMBLY TORQUE**

TABLE 1 - FASTENER SIZE & ASSEMBLY TORQUE				
D=DRY TORQUE- FT-LB (Nm)				
L=LUBED TORQUE- FT-LB(Nm)(SAE30 OIL OR ANTI-SEIZE COMPOUND)				
ALL FASTENERS GRADE 2 OR BETTER				
SIZE	ELEMENT TO SPIDER	TORQUE	DRUM TO HUB	TORQUE
4CB200	1/4-20NC	D7(10)	---	---
6CB200	3/8-16NC	D15(20)	3/8-16NC	D15(20)
8CB250			1/2-13NC	D38(51)
10CB300				
12CB350				
14CB400			1/2-13NC	D38(51)
16CB500				
18CB500				
20CB500				
22CB500				
24CB500				
26CB525	5/8-11NC	D77(104)		
28CB525				
30CB525				
32CB525				
36CB525			3/4-10NC	L93(126)
40CB525				
45CB525				

Dual assemblies use the same values as listed above. For element to element fasteners, use element to spider fastener sizes and torque value.

## 2.3 Mounting Spider and Drum Hub

- 2.3.1 The spider and drum hub are bored for a press fit on to their respective shafts. The interference is approximately .0005in, per inch (.0005mm/mm) of shaft diameter.
- 2.3.1.1 Ensure the shaft is clean and free of nicks or burrs and check the shaft and bore diameters for proper fit.
- 2.3.1.2 Tap the key into the key way, making sure it bottoms.
- 2.3.1.3 Apply a light coat of anti-seizing compound to the shaft and key.
- 2.3.1.4 Heat the drum hub or spider uniformly to 250° F(121 °C) to expand the bore.



### Caution:

**It is recommended the drum hub or spider be heated in oil or an oven; however, since this is not always possible, torches may be used. When using torches, use several with “rose bud” (broad-flame) tips and keep them moving to avoid “hot spots”. Check bore temperature frequently to avoid overheating.**

- 2.3.1.5 Slide the heated drum hub or spider onto the shaft until the hub face is flush with the end of the shaft. Hold in position and allow to cool.

SINGLE ELEMENTS	“X”in. (mm)	DUAL ELEMENTS	“X”in. (mm)
6CB200	3.25(082.6)	—	—
8CB250	3.75(095.3)	—	—
10CB300	4.375(111.2)	—	—
12CB350	5.000(127.0)	12CB350	10.500(266.7)
14CB400	5.500(139.7)	14CB400	11.500(292.1)
16CB500	7.062(179.4)	16CB500	14.000(355.6)
18CB500	7.062(179.4)	18CB500	14.000(355.6)
20CB500	7.062(179.4)	20CB500	14.000(355.6)
22CB500	7.062(179.4)	22CB500	14.000(355.6)
24CB500	7.062(179.4)	24CB500	14.000(355.6)
26CB525	7.500(190.5)	26CB525	14.625(371.5)
28CB525	7.500(190.5)	28CB525	14.750(374.7)
30CB525	7.500(190.5)	30CB525	14.750(374.7)
32CB525	7.500(190.5)	32CB525	14.750(374.7)
36CB525	7.500(190.5)	36CB525	14.750(374.7)
40CB525	7.500(190.5)	40CB525	14.750(374.7)
45CB525	7.500(190.5)	45CB525	14.750(374.7)

## 2.4 Shaft Alignment

Note: The text in this section applies to gap-mounted applications; however, the alignment tolerances apply to all types of mountings.

### Parallel Alignment Tolerance (Offset set):

**Not to exceed 0.010 inch (.254mm) Total Indicator Reading (0.005 in. (.127mm) maximum offset).**

### Angular Alignment Tolerance (Gap):

**Not to be exceed 0.0005 inch per inch (.0005mm/mm) diameter at which readings are taken (“D” on Fig. 8).**

Note: The alignment procedure described below has been used successfully on many CB clutch and brake applications. Other procedures, of course, may be used; however, the alignment tolerances are the same regardless of the technique used.

- 2.4.1 Foundations must be set so distance “X”, shown in Figure 8, is established. If the clutch is mounted on a shaft having plain bearings, make sure the shaft is centered within the bearings when establishing the “X” dimension. Refer to Table 2 for appropriate “X” dimensions.

Note: It is presumed that one of the shafts has been properly located and anchored.

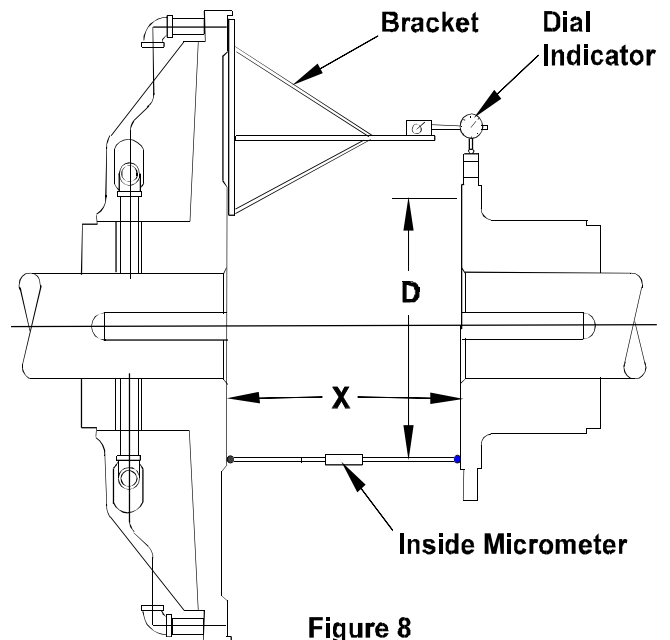


Figure 8

- 2.4.2. Fabricate a rigid bracket for supporting a dial indicator and attach to the spider. See Figure 8.
- 2.4.3. Thoroughly clean the flange O.D. And the face of the drum hub where alignment readings are to be taken.
- 2.4.4. Rotate the spider and take parallel alignment readings off the drum hub flange O.D.If both shafts can be rotated together, the alignment readings are less influenced by any surface irregularities.



**Caution:**

**When recording parallel alignment readings, "Sag" of the indicator/indicator bracket must be accounted for.**

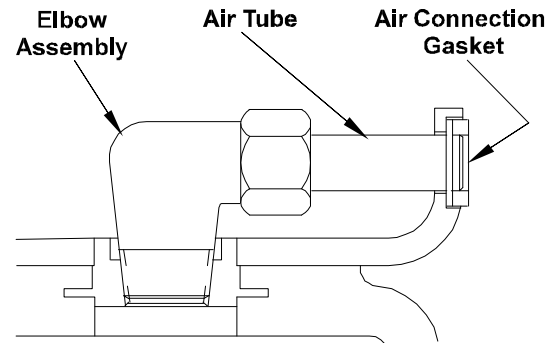
- 2.4.5. Angular alignment readings can be made by accurately measuring the gap between the spider and drum hub faces with an inside micrometer. If a dual indicator is used, make sure to monitor and correct for any axial movement of the shaft. To reduce the influence any surface irregularities may have on the angular alignment readings, index the spider 90 degrees after taking the initial set of readings. Take an additional set of readings and index the spider another 90 degrees. Continue in this manner until four sets of readings have been taken. For misalignment correction use the average of the four readings, the four bottom readings, and each of the four side readings.
- 2.4.6. Shim and shift the base of the movable shaft to correct the misalignment. After tightening the base, recheck the alignment and correct. If necessary. Make sure to check for a "soft foot" condition. Dowel or chock into position after satisfactory alignment has been achieved.

Note: On many applications, thermal growth of the driving or driven machinery may result in unacceptable shaft alignment in a running condition. It is always good practice to make a "hot alignment" check and re-shim if necessary.

**2.5 Installation of Element and Drum (Single and Dual)**

- 2.5.1. Note the orientation of the drum flange with respect to the air connection(s) on the element and slide the drum into the element.

- 2.5.2. Separate the shafts as far as the bearing clearances will allow and hoist the element/drum into position.
- 2.5.3. Attach the drum to the drum hub with the appropriate fasteners. See Table 1. Make sure the bore in the drum flange fully engages the pilot on the drum hub.
- 2.5.4. Apply a small amount of gasket cement to the air connection gaskets to hold the min position during installation. Install the air connection gaskets onto the air tubes. See Figure 9.



**Figure 9**

- 2.5.5. Align the element air connections with the passages in the spider and attach the element to the spider with the appropriate fasteners. See Table 1. Make sure the element fully engages the register in the spider.

**2.6 Air Control System**

- 2.6.1. A typical air control system is shown in Figure 10. Since the air control system used will be dependent on the specific application, a detailed description cannot be made in this manual. Following are some general guidelines for installing and adjusting air controls.
  - 2.6.1.1. The air receiver tank must be located as close to the rotor seal as possible (within five feet) for consistent clutch or brake response.
  - 2.6.1.2. Usefull size piping and valves consistent with the rotor seal size.
  - 2.6.1.3. Keep the number of elbows to a minimum.
  - 2.6.1.4. Use poppet-type solenoid valves. Spool valves are not recommended.
  - 2.6.1.5. An air line lubricator is not required for the element; however, if one is used, it must be a non-adjustable mist-type.

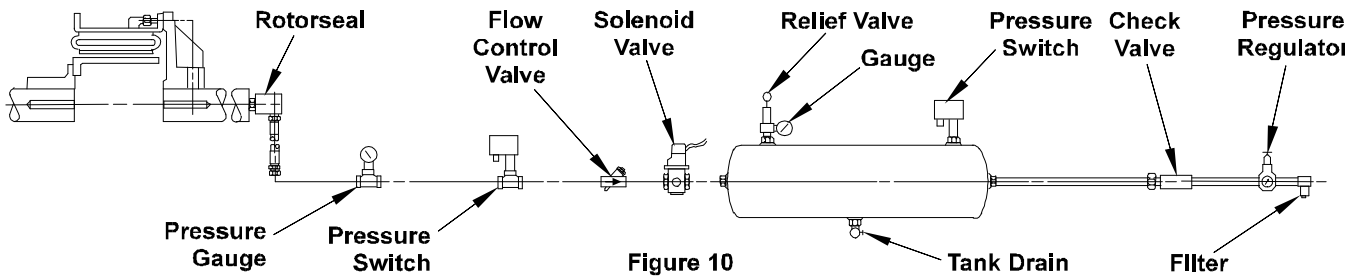


Figure 10

- 2.6.1.6 If a flow control valve is used, it must have free flow (indicated by an arrow on the valve body) directed away from the element.
- 2.6.1.7 The final connection to the rotor seal MUST be made with flexible hose and place no radial load upon the rotor seal.

**! Caution:**

Do not use rigid pipe at the connection to the rotor seal. Rigid piping will result in excessive loads on the rotor seal bearings, shortening life.

**! Caution:**

Maximum applied air pressure is 110 psig (7.5 bar). Operation at pressures exceeding 110 psig may result in damage to the element. Consult the factory if operation at pressures greater than 110 psig is desired.

damage to the element. Consult the factory if operation at pressures greater than 110 psig is required.

**! Caution:**

The non-asbestos friction material used in Airflex CB units may not develop rated torque initially. A short "wear in" period is required. Clutch or brake operation should be monitored closely to prevent excessive heat generation from slippage.

- 3.1.2 Maximum safe operating speeds are shown in Table 3.

**! Danger:**

Do not exceed the operating speeds shown in Table 3. Operation at speeds greater than allowable will result in permanent damage to the element, personal injury or death.

### 3.0 OPERATION

**! Warning:**

Exceeding the operating limits described in this section may result in personal injury or equipment damage.

#### 3.1 Torque, RPM and Pressure Limits

- 3.1.1 The developed torque is dependent upon the applied air pressure and operating speed. If the developed torque seems inadequate, check for oil, grease or dust contamination.

**! Caution:**

Maximum applied air pressure is 110 psig (7.5 bar). Operation at pressures exceeding 110 psig may result in

TABLE 3 MAXIMUM SAFE OPERATING SPEEDS	
SIZE	MAXIMUM RPM
4CB200	1800
6CB200	1800
8CB250	1800
10CB300	1800
12CB350	1800
14CB400	1800
16CB500	1550
18CB500	1400
20CB500	1300
22CB500	1250
24CB500	1200
26CB525	1100
28CB525	1000
30CB525	950
32CB525	900
36CB525	800
40CB525	750
45CB525	700

## 4.0 MAINTENANCE



### Warning:

Only qualified personnel should maintain and repair these units. Faulty workmanship may result in personal injury or equipment damage.



### Caution:

When replacing components, use only genuine Airflex replacement parts. Use of other materials may severely effect performance.

## 4.1 Periodic Inspection

4.1.1 The following items may be inspected without disassembly of the element:

4.1.1.1 **Air Control Components** -Check for proper adjustment of the air control components. Make sure the safety pressure switches, if used, are set correctly. Repair any air leaks.

4.1.1.2 **Friction Shoe Assembly Lining Wear**  
If the linings have worn to the minimum allowable thickness of 1/16" (1.5mm), they must be replaced as a complete set, with the exception of element size 4CB200, where replacement of the entire element is required when worn to the minimum lining thickness of 1/32" (0.8mm).



### Caution:

Operation with friction material worn to less than minimum allowable thickness will result in damage to the drum.

4.1.1.3 **Contamination of Shoes or Drum** -Oil Or grease contamination will reduce the developed torque of the clutch or brake. Disassembly will be required to clean any oil or grease build-up. Any dust accumulation may be vacuumed from between the friction shoe assemblies.



### Caution:

Do not attempt to use a solvent to remove oil or grease without first removing the element. While squirting a solvent into an installed clutch



### Caution:

Do not use compressed air to blow dust accumulations out from between the friction shoes. Although the friction material does not contain asbestos, the dust created as the friction material wears, along with the dust from the operating environment, may irritate the respiratory system.

4.1.2 Partial or complete disassembly is required to inspect the following items:

4.1.2.1 **Drum Diameter Wear** -Check the O.D. of the drum and compare to the values shown on Table 4. Minor heat-checking may be removed by machining the drum O.D. If the drum has been subjected to excessive heat, the open end may flare out, giving the impression that the drum has not worn. It is therefore important to check the diameter at several locations across the face.



### Caution:

Operation of the clutch or brake on a drum that has worn, or has been machined, to less than minimal allowable diameter will result in damage to the element components.

**TABLE 4 - DRUM WEAR LIMITS**

Element Size	Maximum Allowable Wear on Drum Diameter*, in.(mm)
4CB200 thru 14CB400	.09 (2)
16CB500 thru 24CB500	.12 (3)
26CB525 thru 40CB525	.19 (5)
45CB525	.25 (6)

\*Note: The number preceding the letters "CB" in the element size designates the original drum diameter in inches.

Example: For 10CB300-Original Drum Diameter=10.00 inches (254mm)  
Minimum allowable drum diameter is:  
10.00-.09=9.91(254-2=252mm).

4.1.2.2 **Air Actuating Tube** -Check that the rubber tube has not been damaged by excessive heat. If any portion of the tube is hard or charred, the entire element must be replaced. Check for any blisters, which would indicate ply separation. A tube in this condition also requires replacement of the entire element.

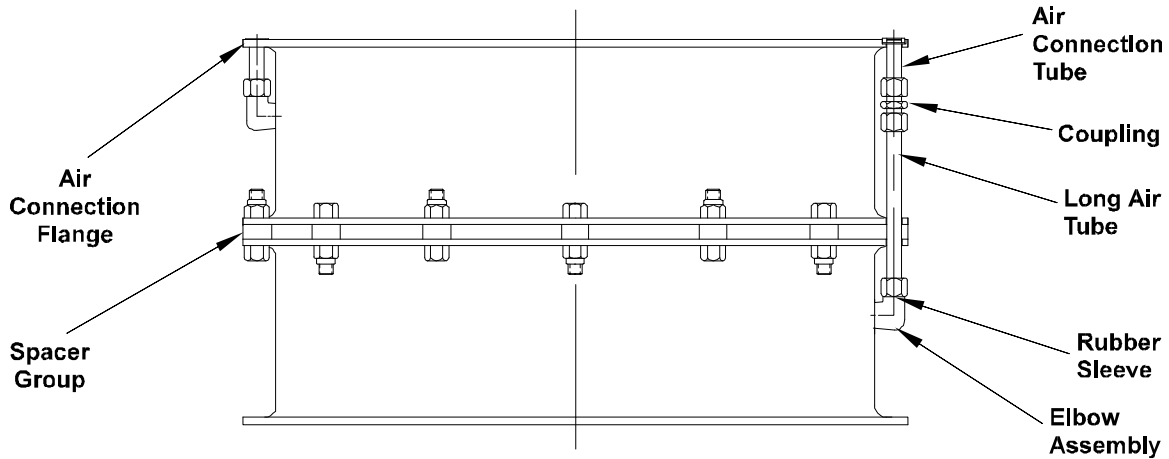


Figure 11

- 4.1.2.3 **Friction Shoe Surface** -If the linings are glazed, they may be lightly sanded to remove the glazing **PROVIDING THEY DO NOT CONTAIN ASBESTOS.**



**Warning:**

Clean the edge of the lining and note the presence of a green stripe and a yellow stripe along with brass flakes in the friction material. If the above exists, the linings contain asbestos. Using the appropriate precautions for working with asbestos, remove the linings and dispose of properly. **DO NOT ATTEMPT TO SAND FRICTION MATERIAL CONTAINING ASBESTOS.**



**Caution:**

When working with any friction material, regardless of whether or not it contains asbestos, always wear approved safety equipment.

- 4.1.2.4 **Uneven Friction Lining Wear** -Tapered wear across the friction surface typically indicates a worn drum and/or misalignment.

- 4.1.2.5 **Contamination of Friction Shoes** -Mild oil Grease contamination may be removed with a solvent. Linings which have become saturated must be replaced. Also, linings that have been charred from excessive heat must be replaced.



**Caution:**

When using any solvent, always follow the appropriate safety precautions.

## 4.2 Removal of Element Assembly and Drum (Single and Dual)



**Warning:**

Prior to removal of the clutch or brake, make sure the machinery is in, and will remain in, a safe condition.

- 4.2.1 Match mark the element to the spider and the drum to the drum hub.
- 4.2.2 Disconnect the element from the spider and allow it to rest on the drum, being careful not to lose the rubber air connection gaskets.
- 4.2.3 Connect an overhead support to the element and apply enough tension to support the weight of the element and drum.
- 4.2.4 Remove the fasteners attaching the drum to the drum hub and hoist the element/drum out from between these shafts.



**Caution:**

Use extreme care when disconnecting the drum from the hub. Shear points exist at the mounting holes.

## 4.3 Disassembly of the Dual Element

- 4.3.1 Lay the element on a clean, level work surface with the air connection flange facing up.
- 4.3.2 Disassemble the long air tube group. See Figure 11.
- 4.3.3 Remove the fasteners attaching the individual elements together and separate the elements.

## 4.4 Removal of Spider and DrumHub

- 4.4.1 Puller holes are provided for removal. It will usually require heating along with the puller. When heating, heat uniformly to prevent hot spots.

## 4.5 Friction Shoe Replacement



### Caution:

**Use only genuine Airflex replacement parts. Use of other materials may adversely effect performance.**

- 4.5.1 Remove the shoe pin lockwires and discard. Withdraw the shoe pins from the element.
- 4.5.2 Remove the friction shoe assemblies from the element.
- 4.5.3 Place the new friction shoe assemblies in position. Insert the shoe pins with the heads located on the mounting flange and/or air connection side of the element, as in Figure 12.

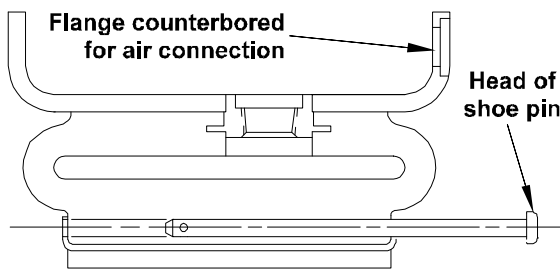


Figure 12

- 4.5.4 Slide lockwires through the holes of the shoe pins making sure that the scallop or bend in the wire points away from the friction material. Each lockwire should go through two shoe pins, securing one friction shoe. See Figure 13.
- 4.5.5 Center the lockwire so that equal lengths extend from each shoe pin. Bend each end of wire inward toward the friction material and around the shoe pin, as in Figure 13.

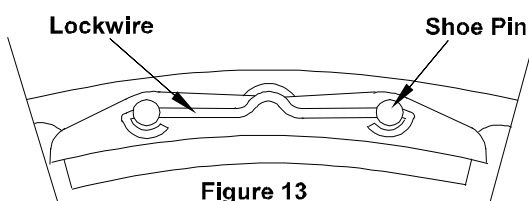


Figure 13

## 5.0 SPARE PARTS STORAGE

### 5.1 Element Assemblies

- 5.1.1 Element assemblies must always be stored flat. Storage in the standing position may cause the rims to go out-of-round.

### 5.2 Drums

- 5.2.1 Drums must be stored open end down, in a dry environment. Similar to element assemblies, storage of a drum in the standing position will adversely affect roundness.

## 6.0 ORDERING INFORMATION

### 6.1 Product Nameplate

- 6.1.1 In any correspondence regarding Airflex equipment, refer to the information on the product nameplate.

### 6.2 Element Description/Identification

- 6.2.1 In the event the product name plate is not available or is illegible, note the following element characteristics:

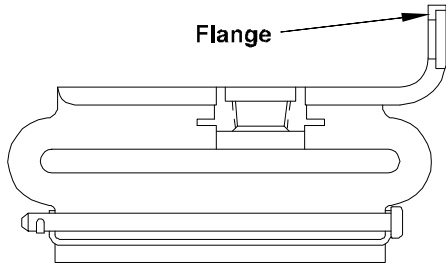
- 6.2.1.1 **Mounting Arrangement** -See section 2.1 of this manual for descriptions of various mounting arrangements.

- 6.2.1.2 **Drum Diameter** -Measure the O.D. Of the drum, to the nearest inch.

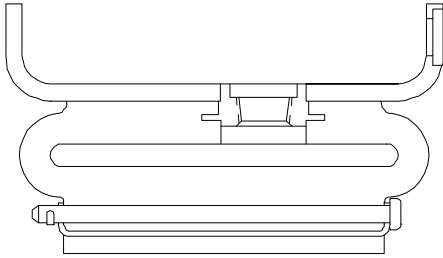
- 6.2.1.3 **Rim Style** - Referring to Figure 14, note any special rim features.

- 6.2.1.4 **Air Connection Configuration** -Note the number of valves, and method of connection to the air supply. See Figure 15.

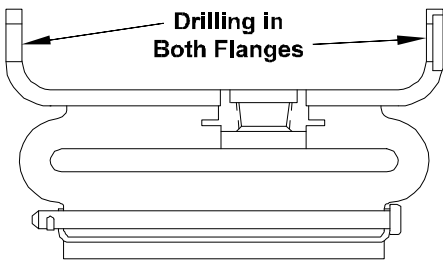
**RIM STYLES - Figure 14**



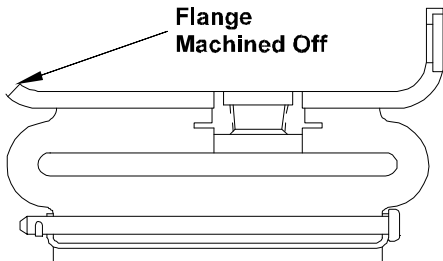
**Figure 14a - Single Flange**



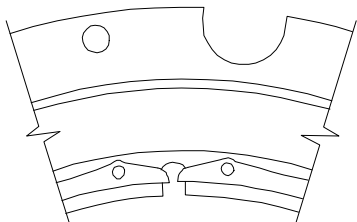
**Figure 14b - Dual Flange**



**Figure 14c - Dual Drilled**

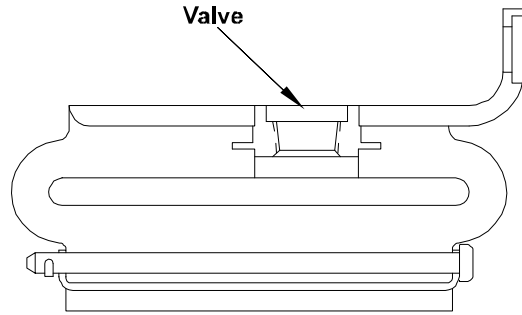


**Figure 14d - Turned Down Flange**

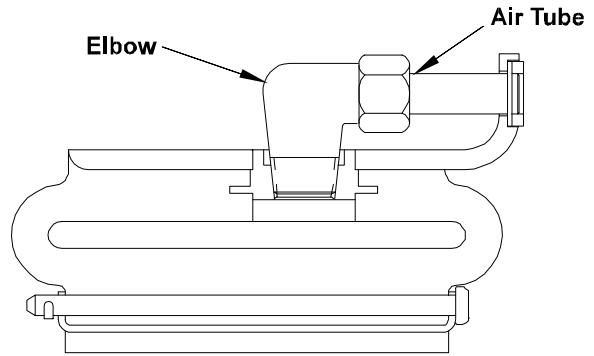


**Figure 14e - Slotted Rim**

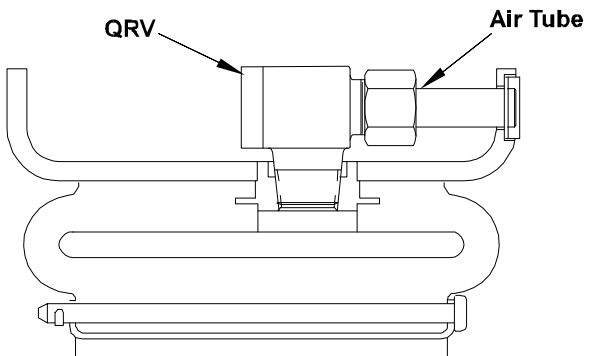
**AIR CONNECTIONS - Figure 15**



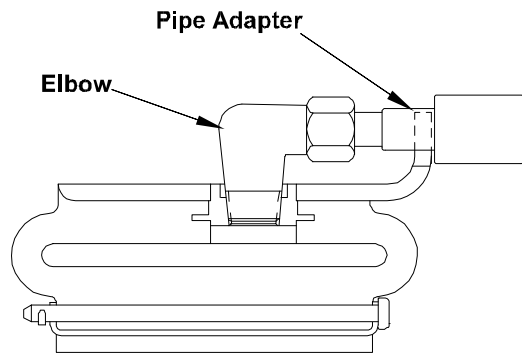
**Figure 15a - Number of Valves**



**Figure 15b - Side Connection**



**Figure 15c - Quick Release Valve (QRV)**



**Figure 15d - Pipe Adapter**

**THE PARTS LISTS IN THIS MANUAL APPLY TO STANDARD ELEMENT ASSEMBLIES ONLY. ELEMENTS USED ON SLIP OR HIGH-TORQUE APPLICATIONS WILL HAVE DIFFERENT COMPONENTS PARTS. CONSULT THE AIRFLEX FACTORY OR AN AUTHORIZED AIRFLEX DISTRIBUTOR PRIOR TO ORDERING REPLACEMENT PARTS FOR ANY ELEMENT NOT APPEARING IN THESE PARTS LISTS.**

## 7.0 PARTS LISTS

### 7.1 Single Element Assemblies

	Element Description	No. of Air Inlets	Part No. of Complete Element	ITEM													
				1 Elbow Assy.		1A QRV		2 Comp. Ring		3 Air Conn. Tube		4 Air Conn. Gasket		5 FSA	8 Shoe Pin	9 Lockwire	
				Part No.	Qty.	Part No.	Qty.	Part No.	Qty.	Part No.	Qty.	Part No.	Qty.	Part No.	Part No.	Part No.	
<b>4CB 200</b>	Minus Side Connection	1	414361	---	---	---	---	---	---	---	---	---	---	---	---	---	
	90 Degree Elbow for use in PCB 206	1	142840JD	341 X 1	1	---	---	---	---	---	---	---	---	---	---	---	
	Side Connection	1	142840JB	131 X 33	1	---	---	87 X 27	1	202723	1	72 X 39	1	---	---	---	
<b>6CB 200</b>	Minus Side Connection	1	142095JA	---	---	---	---	---	---	---	---	---	---	307398 6 Req'd.	200356 12 Req'd.	412266-04 6 Req'd.	
	Minus Side Connection for use in PCB	1	142095JC	---	---	---	---	---	---	---	---	---	---				
	Minus Side Connection	2	142095JH	---	---	---	---	---	---	---	---	---	---				
	Side Connection	1	142095JB	131 X 11	1	---	---	131 X 20	1	9943	1	72 X 15	1				---
	Side Connection	2	142095JG		2	---	---		1		---						
	Side Connection and High Coefficient Lining	1	142095JN		1	---	---		1		---		303261 6 Req'd.				
<b>8CB 250</b>	Minus Side Connection	1	142096JA	---	---	---	---	---	---	---	---	---	---	307461 8 Req'd.	9434 16 Req'd.	412266-04 8 Req'd.	
	Minus Side Connection for use in PCB	1	142096JC	---	---	---	---	---	---	---	---	---	---				
	Minus Side Connection	2	142096JH	---	---	---	---	---	---	---	---	---	---				
	Side Connection	1	142096JB	131 X 11	1	---	---	131 x 20	1	9944	1	72 x 15	1				---
	Side Connection	2	142096JG		2	---	---		2		---						
	Side Connection and High Coefficient Lining	1	145096JN		1	---	---		1		---		303370 8 Req'd.				

	Element Description	No. of Air Inlets	Part No. of Complete Element	ITEM												
				1 Elbow Assy.		1A QRV		2 Comp. Ring		3 Air Conn. Tube		4 Air Conn. Gasket		5 FSA	8 Shoe Pin	9 Lockwire
				Part No.	Qty.	Part No.	Qty.	Part No.	Qty.	Part No.	Qty.	Part No.	Qty.	Part No.	Part No.	Part No.
10CB 300	Minus Side Connection	1	142197JA	—	—	—	—	—	—	—	—	—	—	307348 10 Req'd.	9492 20 Req'd.	412266-04 10 Req'd
	Minus Side Connection for use in PCB	1	142197JC	—	—	—	—	—	—	—	—	—	—			
	Minus Side Connection	2	142197JH	—	—	—	—	—	—	—	—	—	—			
	Side Connection	1	142197JB	131 X 11	1	—	—	131x20	1	9944	1	72 x 15	1			
	Side Connection	2	142197JG		2	—	—		2		2					
	Side Connection and High Coefficient Lining	1	145097JN	1	—	—	1	1	1							
	Minus Side Connection High Coefficient Lining	1	145097JT	—	—	—	—	—	—	—	—	—	303197 10 Req'd.			
12CB 350	Minus Side Connection	1	142098JA	—	—	—	—	—	—	—	—	—	307436 12 Req'd.	9508 24 Req'd.	412266-04 12 Req'd.	
	Minus Side Connection for use in PCB	1	142098JC	—	—	—	—	—	—	—	—	—				
	Minus Side Connection	2	142098JH	—	—	—	—	—	—	—	—	—				
	Minus Side Connection Dual Drilled	2	142098KG	—	—	—	—	—	—	—	—	—				
	Quick Release Valve Dual Flange	2	142098KF	—	—	14506DF	2	—	—	—	—	—				
	Side Connection	1	142098JB	131 X 11	1	—	—	131 x 20	1	9944	1	72 x 15				1
	Side Connection	2	142098JG		2	—	—		2		2					
	Side Connection and High Coefficient Lining	1	145098JN	1	—	—	1	1	1	1	303338 12 Req'd.					
Side Connection for FSPA Mounting	2	142098JZ	131 X 12	2	—	—	131 x 21	2	201714	2	—	—	307436 12 Req'd.			
14CB 400	Minus Side Connection	1	142087JA	—	—	—	—	—	—	—	—	—	307400 14 Req'd.	8863 28 Req'd.	412266-04 14 Req'd.	
	Minus Side Connection for use in PCB	1	142087JC	—	—	—	—	—	—	—	—	—				
	Minus Side Connection	2	142087JH	—	—	—	—	—	—	—	—	—				
	Minus Side Connection Dual Drilled	2	142087KG	—	—	—	—	—	—	—	—	—				
	Side Connection	1	142087JB	131 X 11	1	—	—	131 x 20	1	9944	1	72 x 15				1
	Side Connection	2	142087JG		2	—	—		2		2					
	Side Connection for FSPA Mounting	2	142087JZ	131 X 12	2	—	—	131 x 21	2	201714	2	—				—

	Element Description	No. of Air Inlets	Part No. of Complete Element	ITEM											5 FSA Part No.	8 Shoe Pin Part No.	9 Lockwire Part No.
				1 Elbow Assy.		1A QRV		2 Comp. Ring		3 Air Conn. Tube		4 Air Conn. Gasket					
				Part No.	Qty.	Part No.	Qty.	Part No.	Qty.	Part No.	Qty.	Part No.	Qty.				
16CB 500	Minus Side Connection	1	142211KY	—	—	—	—	—	—	—	—	—	—	41467 10 Req'd	9716 20 Req'd	412266-03 10 Req'd	
	Minus Side Connection Dual Drilled	1	142211KS	—	—	—	—	—	—	—	—	—	—				
	Minus Side Connection	4	142211KZ	—	—	—	—	—	—	—	—	—	—				
	Side Connection	1	142211KM	—	1	—	—	87 X 12	1	—	1	—	1				
	Side Connection Dual Drilled	1	142211LH	92 X 6	1	—	—	87 X 12	1	8518	1	72 X 11	1				
	Side Connection	2	142211LB		2	—	—		2								
	Side Connection	4	142211KP		4	—	—		4								
	Side Connection for FSPA Mounting	4	142211LD		4	—	—		4								
	Quick Release Valve	1	142211KN	—	—	145406DF	1	—	1	1	1						
	Quick Release Valve	2	142211LK	—	—		2	—	2	2							
Quick Release Valve	4	142264KR	—	—	4		—	4	4								
18CB 500	Minus Side Connection	1	142264KY	—	—	—	—	—	—	—	—	—	414745 11 Req'd	9716 22 Req'd	412266-03 11 Req'd		
	Minus Side Connection Dual Drilled	1	142264KS	—	—	—	—	—	—	—	—	—					
	Minus Side Connection	4	142264KZ	—	—	—	—	—	—	—	—	—					
	Side Connection	1	142264KM	92 X 6	1	—	—	87 X 12	1	8518	1	72 X 11				1	
	Side Connection Dual Connection	1	142264LH		1	—	—		1								
	Side Connection Turned Down Flange	1	142264KX		1	—	—		1								
	Side Connection	2	142264LB		2	—	—		2								
	Side Connection	4	142264KP	4	—	—	4	—	4	4	4						
	Quick Release Valve	1	142264KN	—	—	145406DF	1	—	1	1	1						
	Quick Release Valve	2	142264LK	—	—		2	—	2	2							
Quick Release Valve	4	142264KR	—	—	4		—	4	4								
20CB 500	Minus Side Connection	1	142265KY	—	—	—	—	—	—	—	—	—	414770 12 Req'd	9716 24 Req'd	412266-03 11 Req'd		
	Minus Side Connection Dual Drilled	1	142265KS	—	—	—	—	—	—	—	—	—					
	Minus Side Connection	4	142265KZ	—	—	—	—	—	—	—	—	—					
	Side Connection	1	142665KM	92 X 6	1	—	—	87 X 12	1	8518	1	72 X 11				1	
	Side Connection Dual Drilled	1	142265LH		1	—	—		1								
	Side Connection	2	142265LB		2	—	—		2								
	Side Connection	4	142265KP		4	—	—		4								
	Side Connection FSPA Mounting	4	142265LD	4	—	—	4	—	4	4							
	Quick Release Valve	1	142265KN	—	—	145406DF	1	—	1	1	1						
	Quick Release Valve	4	142265KR	—	—		4	—	4	4							

	Element Description	No. of Air Inlets	Part No. of Complete Element	ITEM											5 FSA Part No.	8 Shoe Pin Part No.	9 Lockwire Part No.
				1 Elbow Assy.		1A QRV		2 Comp. Ring		3 Air Conn. Tube		4 Air Conn. Gasket					
				Part No.	Qty.	Part No.	Qty.	Part No.	Qty.	Part No.	Qty.	Part No.	Qty.				
22CB 500	Minus Side Connection	1	142266KY	—	—	—	—	—	—	—	—	—	—	414771 13 Req'd	9716 26 Req'd.	412266-03 13 Req'd.	
	Minus Side Connection Dual Drilled	1	142266KS	—	—	—	—	—	—	—	—	—	—				
	Side Connection	1	142266KM	92 X 6	1	—	—	87 X 12	1	8518	1	72 X 11	1				
	Side Connection Dual Drilled	1	142266LH		1	—	—		1		1						
	Side Connection Turned Down Flange	1	142266KX		1	—	—		1		1						
	Side Connection	4	142266KP		4	—	—		4		4						
	Quick Release Valve	1	142266KN	—	—	—	1	—	1	—	1	—	1				
	Quick Release Valve	2	142266LK	—	—	145406DF	2	—	2	—	2	—	2				
	Quick Release Valve	4	142266KR	—	—	—	4	—	4	—	4	—	4				
24CB 500	Minus Side Connection1	1	142267KY	—	—	—	—	—	—	—	—	—	—	414771 14 Req'd.	9716 28 Req'd.	412266-03 14 Req'd.	
	Minus Side Connection Dual Drilled	1	142267KS	—	—	—	—	—	—	—	—	—	—				
	Minus Side Connection	4	142267KZ	—	—	—	—	—	—	—	—	—	—				
	Side Connection	1	142267KM	92 X 6	1	—	—	87 x 12	1	8518	1	72 x 11	1				
	Side Connection Dual Drilled	1	142267LH		1	—	—		1		1						
	Side Connection	2	142267LB		2	—	—		2		2						
	Side Connection	4	142267KP		4	—	—		4		4						
	Minus Side Connection for FSPA Mounting	4	142267LD	—	—	—	—	4	—	4	—	4	—				
	Quick Release Valve	1	142267KN	—	—	—	1	—	1	—	1	—	1				
Quick Release Valve	4	142267KR	—	—	145406DF	4	—	4	—	4	—	4					
26CB 525	Minus Side Connection	1	142268KY	—	—	—	—	—	—	—	—	—	—	414772 16 Req'd.	9513 32 Req'd.	412266-02 16 Req'd.	
	Minus Side Connection Dual Drilled	1	142268KS	—	—	—	—	—	—	—	—	—	—				
	Minus Side Connection1	4	142268KZ	—	—	—	—	—	—	—	—	—	—				
	Side Connection	1	142268KM	92 X 7	1	—	—	87 X 14	1	8507	1	72 X 12	1				
	Side Connection Dual Drilled	1	142268LH		1	—	—		1		1						
	Side Connection	2	142268LB		2	—	—		2		2						
	Side Connection	4	142268KP		4	—	—		4		4						
	Quick Release Valve	1	142268KN	—	—	—	1	—	1	—	1	—	1				
	Quick Release Valve	4	142268KR	—	—	145407DF	4	—	4	—	4	—	4				

	Element Description	No. of Air Inlets	Part No. of Complete Element	ITEM												
				1 Elbow Assy.		1A QRV		2 Comp. Ring		3 Air Conn. Tube		4 Air Conn. Gasket		5 F S A	8 Shoe Pin	9 Lockwire
				Part No.	Qty.	Part No.	Qty.	Part No.	Qty.	Part No.	Qty.	Part No.	Qty.	Part No.	Part No.	Part No.
28CB 525	Minus Side Connection	1	142269KY	—	—	—	—	—	—	—	—	—	—	414773 17 Req'd.	9513 34 Req'd.	412266-02 17 Req'd.
	Minus Side Connection Dual Drilled	1	142269KS	—	—	—	—	—	—	—	—	—	—			
	Minus Side Connection	4	142269KZ	—	—	—	—	—	—	—	—	—	—			
	Side Connection	1	142269KM	92 X 7	1	—	—	87 X 14	1	8507	1	72 x 12	1			
	Side Connection Dual Drilled	1	142269LH		1	—	—		1		1					
	Side Connection	2	142269LB		2	—	—		2		2					
	Side Connection	4	142269KP		4	—	—		4		4					
	Side Connection for FSPA Mounting	4	142269LD		4	—	—		4		4					
	Quick Release Valve	1	142269KN	—	—	145407DF	1	1	1	1	1	1				
Quick Release Valve	4	142269KR	—	—	4		4	4	4	4	4					
30CB 525	Minus Side Connection	1	142270KY	—	—	—	—	—	—	—	—	—	414774 18 Req'd.	9513 36 Req'd.	412266-02 18 Req'd.	
	Minus Side Connection Dual Drilled	1	142270KS	—	—	—	—	—	—	—	—	—				
	Side Connection	1	142270KM	92 X 7	1	—	—	87 X 14	1	8507	1	72 x 12				1
	Side Connection Dual Drilled	1	142270LH		1	—	—		1		1					
	Side Connection	4	142270KP		4	—	—		4		4					
	Quick Release Valve	1	142270KN	—	—	145407DF	1	1	1	1	1					
Quick Release Valve	4	142270KR	—	—	4		4	4	4	4						
32CB 525	Minus Side Connection	1	142271KY	—	—	—	—	—	—	—	—	—	414775 19 Req'd.	9513 38 Req'd.	412266-02 19 Req'd.	
	Minus Side Connection Dual Drilled	1	142271KS	—	—	—	—	—	—	—	—	—				
	Minus Side Connection	4	142271KZ	—	—	—	—	—	—	—	—	—				
	Side Connection	1	142271KM	92 X 7	1	—	—	87 X 14	1	8507	1	72 x 12				1
	Side Connection Dual Drilled	1	142271LH		1	—	—		1		1					
	Side Connection	2	142271LB		2	—	—		2		2					
	Side Connection	4	142271KP		4	—	—		4		4					
	Quick Release Valve	1	142271KN	—	—	145407DF	1	1	1	1	1					
Quick Release Valve	4	142271KR	—	—	4		4	4	4	4						

	Element Description	No. of Air Inlets	Part No. of Complete Element	ITEM												
				1 Elbow Assy.		1A QRV		2 Comp. Ring		3 Air Conn. Tube		4 Air Conn. Gasket		5 FSA	8 Shoe Pin	9 Lockwire
				Part No.	Qty.	Part No.	Qty.	Part No.	Qty.	Part No.	Qty.	Part No.	Qty.	Part No.	Part No.	Part No.
36CB 525	Minus Side Connection	1	142272KY	—	—	—	—	—	—	—	—	—	414775 22 Req'd.	9513 44 Req'd.	412266-02 22 Req'd.	
	Minus Side Connection Dual Drilled	1	142272KS	—	—	—	—	—	—	—	—	—				
	Side Connection	1	142272KM	92 X 8	1	—	87 X 16	1	8501	1	72 x 13	1				
	Side Connection Dual Drilled	1	142272LH		1	—		4		4						
	Side Connection	4	142272KP		4	—		1		1						
	Quick Release Valve	1	142272KN	—	—	145141DE	1	—	—	—	—	—				
	Quick Release Valve	4	142272KR	—	—	—	4	—	—	—	—	—				
40CB 525	Minus Side Connection	1	142273KY	—	—	—	—	—	—	—	—	414776 24 Req'd.	9513 48 Req'd.	412266-02 24 Req'd.		
	Minus Side Connection Dural Drilled	1	142273KS	—	—	—	—	—	—	—	—					
	Side Connection	1	142273KM	92 X 8	1	—	87 X 16	1	8501	1	72 x 13				1	
	Side Connection Dual Drilled	1	142273LH		1	—		2		2						
	Side Connection	2	142273LB		2	—		4		4						
	Side Connection	4	142273KP	—	—	—	—	—	—	—	—				—	
	Quick Release Valve	1	142273KN	—	—	145141DE	1	—	—	—	—				—	
Quick Release Valve	4	142273KR	—	—	—	4	—	—	—	—	—					
45CB 525	Minus Side Connection	2	142081LX	—	—	—	—	—	—	—	—	414775 27 Req'd.	9513 54 Req'd.	412266-02 27 Req'd.		
	Minus Side Connection Dual Drilled	2	142081MT	—	—	—	—	—	—	—	—					
	Side Connection	1	142081KM	92 X 8	1	—	87 X 16	1	8501	1	72 x 13				1	
	Side Connection	2	142081LB		2	—		2		2						

## 7.2 Dual Element Assemblies

ITEM						
	Element Description	Part No. of Complete Element	Inner Element*	Outer Element*	6	7
					Air Tube Group	Spacer Group
12CB400	Two Side Connections	142731DA	142098KG	142098KG	—	—
14CB400	Two Side Connections	142604DA	142087KG	142087KG	106345	106350
16CB500	Two Side Connections	142432DA	142211KS	142211KY	106346	106351
	Two Quick Release Valves	142432DD			106346B	
18CB500	Two Side Connections	142433DA	142264KS	142264KY	106346	106352
	Two Quick Release Valves	142433DD			106346B	
20CB500	Two Side Connections	142434DA	142265KS	142265KY	106346	
	Two Quick Release Valves	142434DD			106346B	
22CB500	Two Side Connections	142435DA	142266KS	142266KY	106346	
	Two Quick Release Valves	142435DD			106346B	
24CB500	Two Side Connections	142436DA	142267KS	142267KY	106346	106353
	Two Quick Release Valves	142436DD			106346B	
26CB525	Two Side Connections	142437DA	142268KS	142268KY	106347	106354
	Two Quick Release Valves	142437DD			106347B	
28CB525	Two Side Connections	142438DA	142269KS	142269KY	106347	106355
	Two Quick Release Valves	142438DD			106347B	
30CB525	Two Side Connections	142439DA	142270KS	142270KY	106347	
	Two Quick Release Valves	142439DD			106347B	
32CB525	Two Side Connections	142440DA	142271KS	142271KY	106347	106356
	Two Quick Release Valve	142440DD			106347B	
36CB525	Two Side Connections	142441DA	142272KS	142272KY	106348	106357
	Two Quick Release Valve	142441DD			106348B	
40CB525	Two Side Connections	142442DA	142273KS	142273KY	106348	106358
	Two Quick Release Valve	142442DD			106348B	
45CB525	Four Side Connections	142443DK	142081MT	142081LX	106348 2 Req'd.	106359
	Four Quick Release Valves	142443DL			106348B 2 Req'd.	

\*Notes: The inner element is that which both the short and long air tubes pass through.  
To find part numbers of components, locate the element number in the parts list for single element application. Find the part numbers in the corresponding item column.

## 8.0 REPAIR KITS

### 8.1 Friction Shoe, Shoe Pin and Lockwire Kits

<b>ELEMENT SIZE</b>	<b>KIT NUMBER</b>	<b>QTY. FRICTION SHOES</b>	<b>QTY. SHOE PINS</b>	<b>QTY.* LOCKWIRES</b>
6CB200	146234A	6	12	6
8CB250	146234B	8	16	8
10CB300	146234C	10	20	10
12CB350	146234D	12	24	12
14CB400	146234E	14	28	14
16CB500	146234F	10	20	10
18CB500	146234G	11	22	11
20CB500	146234H	12	24	12
22CB500	146234J	13	26	13
24CB500	146234K	14	28	14
26CB525	146234L	16	32	16
28CB525	146234M	17	34	17
30CB525	146234N	18	36	18
32CB525	146234P	19	38	19
36CB525	146234Q	22	44	22
40CB525	146234R	24	48	24
45CB525	146234S	27	54	27

\* Extra lockwires supplied with each kit.

**Products we offer:**

- Cartridge valves
- DCV directional control valves
- Electric converters
- Electric machines
- Electric motors
- Gear motors
- Gear pumps
- Hydraulic integrated circuits (HICs)
- Hydrostatic motors
- Hydrostatic pumps
- Orbital motors
- PLUS+1<sup>®</sup> controllers
- PLUS+1<sup>®</sup> displays
- PLUS+1<sup>®</sup> joysticks and pedals
- PLUS+1<sup>®</sup> operator interfaces
- PLUS+1<sup>®</sup> sensors
- PLUS+1<sup>®</sup> software
- PLUS+1<sup>®</sup> software services, support and training
- Position controls and sensors
- PVG proportional valves
- Steering components and systems
- Telematics

**Danfoss Power Solutions** is a global manufacturer and supplier of high-quality hydraulic and electric components. We specialize in providing state-of-the-art technology and solutions that excel in the harsh operating conditions of the mobile off-highway market as well as the marine sector. Building on our extensive applications expertise, we work closely with you to ensure exceptional performance for a broad range of applications. We help you and other customers around the world speed up system development, reduce costs and bring vehicles and vessels to market faster.

Danfoss Power Solutions – your strongest partner in mobile hydraulics and mobile electrification.

**Go to [www.danfoss.com](http://www.danfoss.com) for further product information.**

We offer you expert worldwide support for ensuring the best possible solutions for outstanding performance. And with an extensive network of Global Service Partners, we also provide you with comprehensive global service for all of our components.

Local address:

**Hydro-Gear**

[www.hydro-gear.com](http://www.hydro-gear.com)

**Daikin-Sauer-Danfoss**

[www.daikin-sauer-danfoss.com](http://www.daikin-sauer-danfoss.com)

**Danfoss  
Power Solutions (US) Company**  
2800 East 13th Street  
Ames, IA 50010, USA  
Phone: +1 515 239 6000

**Danfoss  
Power Solutions GmbH & Co. OHG**  
Krokamp 35  
D-24539 Neumünster, Germany  
Phone: +49 4321 871 0

**Danfoss  
Power Solutions ApS**  
Nordborgvej 81  
DK-6430 Nordborg, Denmark  
Phone: +45 7488 2222

**Danfoss  
Power Solutions Trading  
(Shanghai) Co., Ltd.**  
Building #22, No. 1000 Jin Hai Rd  
Jin Qiao, Pudong New District  
Shanghai, China 201206  
Phone: +86 21 2080 6201