

Contents

1.0 INTRODUCTION	6
1.1 Description	6
1.2 How It works	6
1.3 Clutch adjustment	7
2.0 INSTALLATION	8
2.1 Mounting arrangements	8
2.2 Mounting considerations	8
2.3 Mounting spider and drum hub	10
2.4 Shaft alignment	10
2.5 Axial locking device adjustment	11
2.6 Installation of element and drum (narrow, dual narrow and single wide)	12
2.7 Installation of element and drums (dual wide)	12
2.8 Air control system	14
2.9 Electrical controls	14
3.0 OPERATION	17
3.1 Torque, RPM and pressure limits	17
3.2 Control component adjustment	17
4.0 MAINTENANCE	18
4.1 Periodic inspection	18
4.2 Removal of element assembly and drum (narrow, dual narrow and single wide)	20
4.3 Removal of element assemblies and drums (dual wide)	20
4.4 Removal of spider and drum hub	20
4.5 Disassembly of the element	20
4.6 Friction lining replacement	21
4.7 Assembly of the element	22
5.0 SPARE PARTS STORAGE	22
5.1 Element assemblies	22
5.2 Drums	22
5.3 Air actuating tubes	22
6.0 ORDERING INFORMATION/TECHNICAL ASSISTANCE	23
6.1 Equipment reference	23
7.0 PARTS LISTS	24
7.1 Single narrow element assemblies	24
7.2 Dual narrow element assemblies	24
7.3 Single wide element assemblies	26
7.4 Dual wide element assemblies	28
7.5 Drums	28
7.6 Axial locking devices	28
7.7 Friction block and rivet kits	29
7.8 Friction shoe assembly, torque bar and release spring kits	29
8.0 REVISION	30
9.0 NOTES	31

Airflex model VC Grinding mill clutches



WARNING

Forward this manual to the person responsible for Installation, Operation and Maintenance of the product described here in. Without access to this information, faulty Installation, Operation or Maintenance may result in personal injury or equipment damage.



CAUTION

Use only genuine Airflex® replacements parts. The Airflex Division of Danfoss recommends the use of genuine Airflex replacement parts. The use of non-genuine Airflex replacement parts could result in substandard product performance, and may void your Danfoss warranty. For optimum performance, contact Airflex:

In the U.S.A. and Canada:(800) 233-5926 Outside the U.S.A. & Canada: (216) 281-2211

Airflex VC Grinding mill clutches

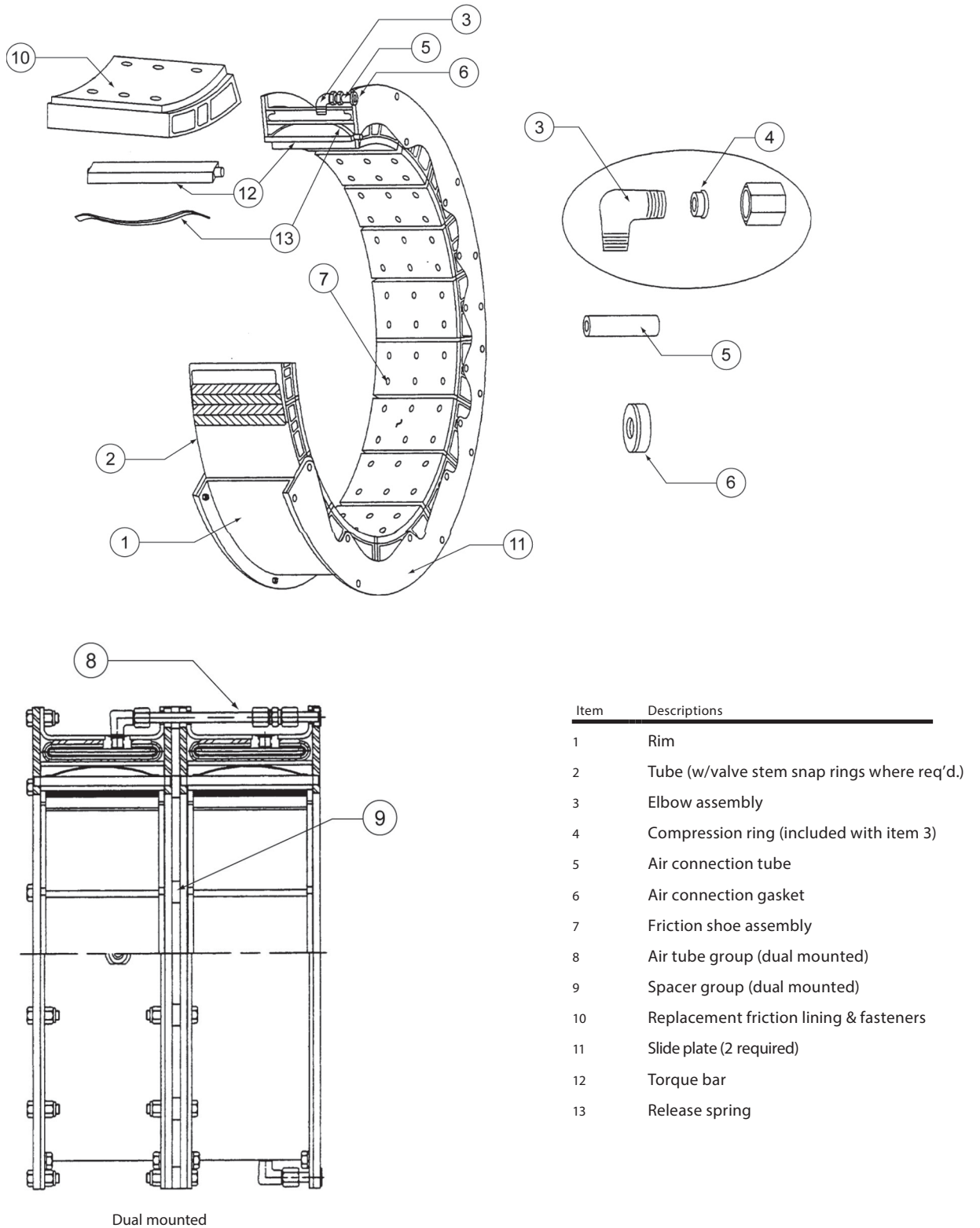



Figure 1. Component parts for Airflex type VC element

Airflex model VC Grinding mill clutches

1.0 Introduction

Throughout this manual there are a number of HAZARD WARNINGS that must be read and adhered to in order to prevent possible personal injury and/or damage to equipment. Three signal words "DANGER", "WARNING" and "CAUTION" are used to indicate the severity of a hazard, and are preceded by the safety alert symbol 

DANGER

Denotes the most serious hazard, and is used when serious injury or death WILL result from misuse or failure to follow specific instructions.

WARNING

Used when serious injury or death MAY result from misuse or failure to follow specific instructions.

CAUTION

Used when injury or product/equipment damage may result from misuse or failure to follow specific instructions.

It is the responsibility and duty of all personnel involved in the installation, operation and maintenance of the equipment on which this device is used to fully understand the:

DANGER

WARNING

CAUTION

procedures by which hazards can be avoided.

1.1 Description

- 1.1.1 The Airflex air-actuated VC clutch is specifically designed and manufactured for severe service encountered in grinding mill operations, where high starting loads and sustained slippage would normally lower clutch efficiency and reduce operating life. Constricting action and ventilated construction make high torque capacity and rapid heat dissipation possible.
- 1.1.2 All Airflex VC elements are supplied with long wearing, NON-ASBESTOS friction material.
- 1.1.3 Airflex element assemblies are available for drum diameters from 11.5 inches through 76 inches. The element size designation indicates the nominal drum diameter in inches, the clutch model and the width of the friction material. For example, size "38VC1200" indicates the element operates on a drum having a nominal diameter of 38 inches, is an Airflex 'VC' series clutch and has friction material which is 12 inches wide.
- 1.1.4 Where diameter space is limited, or the torque required is greater than a single element can transmit, all sizes of Airflex VC elements can be supplied as dual units.

1.2 How it works

- 1.2.1 Referring to Figures 1 and 2, the neoprene and cord actuating tube is contained within a steel rim which is drilled for mounting to the driving component. As air pressure is applied to the air actuating tube, the tube inflates, forcing the friction shoe assemblies uniformly against the drum, which is attached to the driven component. The friction shoe assemblies, which consist of friction blocks attached to aluminum backing plates, are guided by torque bars which are secured to side plates. The torque flow is from the driving shaft, through the element mounting component (typically an iron spider), through the rim/side plate structure, through the torque bars to the backing plates and friction material, where the torque is transmitted through the friction couple to the components mounted on the driven shaft (clutch drum and drum mounting component). As actuating air is exhausted, release springs and centrifugal force assure positive disengagement.
 - 1.2.1.1 In some cases, the spider and element assembly may be mounted to the driven shaft rather than the driving shaft. This "reverse-mounted" arrangement is typically used when retrofitting a mill drive and it is more practical to drill the pinion shaft for the air supply rather than the motor shaft. In these cases, the operation and torque flow description is opposite to what is stated above.
 - 1.2.2 For applications where the clutch is mounted on a motor shaft having plain bearings, an axial locking device is used to hold the motor on magnetic center during operation. Refer to the INSTALLATION section for axial locking device adjustment.
 - 1.2.2.1 Figure 3A illustrates another type of axial locking device called a separation restraint. This device is attached to the clutch rim as shown, with a bronze wear pad which rides against the clutch drum to restrict axial movement.

Note: There is no relative motion between the drum and wear pad when the clutch is fully engaged.

Airflex model VC Grinding mill clutches

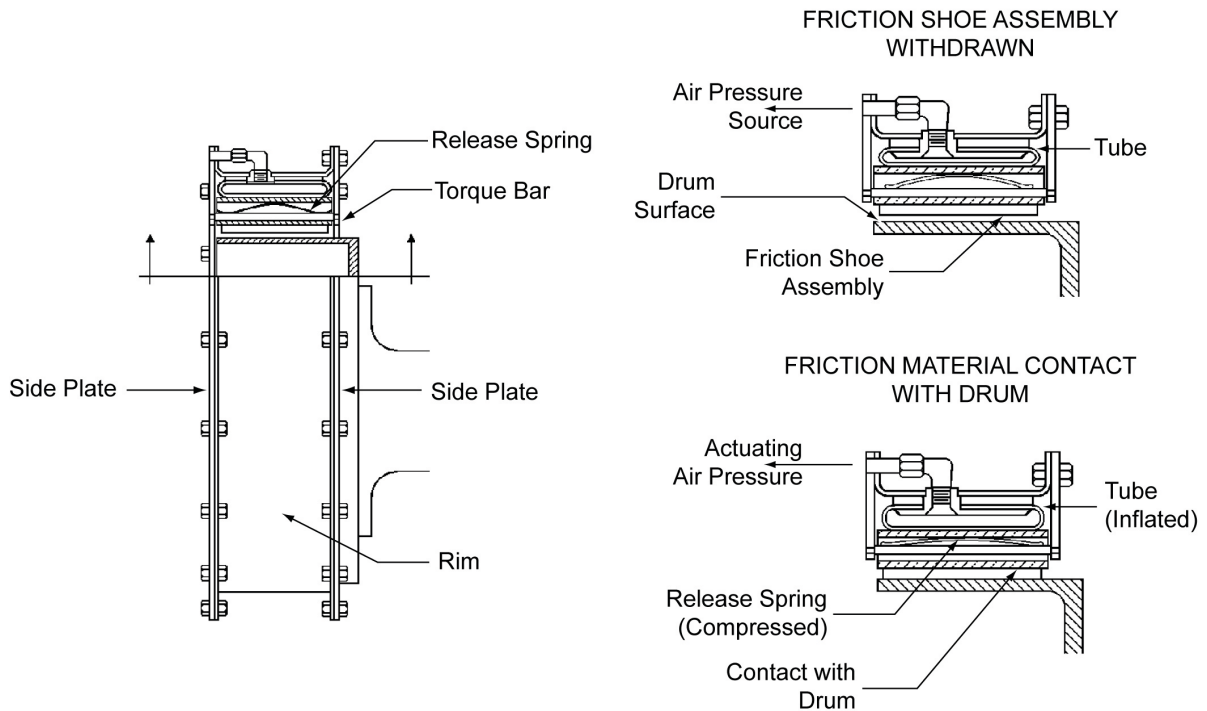

Figure 2

1.3 Clutch adjustment

1.3.1 Airflex VC clutches are completely self-adjusting and automatically compensate for lining and drum wear. Lubrication is not required. The torque developed is dependent upon rotating speed and applied air pressure. By limiting the applied pressure, the element will act as a torque limiting device and provide overload protection.

1.3.2 To achieve the desired mill acceleration time, a flow control valve is installed in the clutch air supply line and adjusted to restrict airflow to the clutch, while allowing free flow away from the clutch for rapid disengagement. By adjusting the flow rate of engagement may be varied. Note that the flow control valve does not regulate air pressure the supply pressure must always be adequate to transmit the maximum required torque. Refer to the INSTALLATION section of this manual for a recommended air piping configuration and the OPERATION section for flow control valve adjustment.

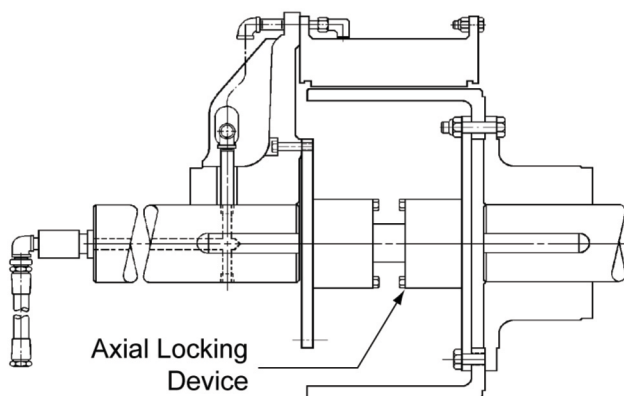

Figure 3

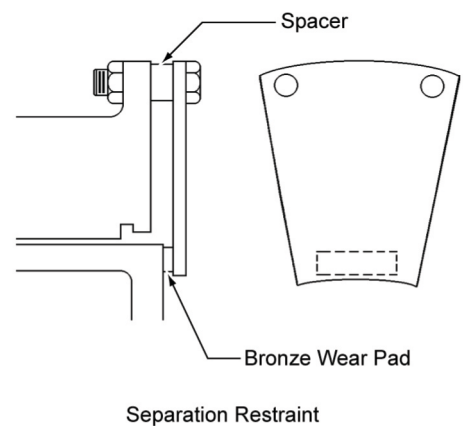

Figure 3A

Airflex model VC Grinding mill clutches

2.0 Installation

⚠ WARNING

Only qualified personnel should install, adjust or repair these units. Faulty workmanship will result in exposure to hazardous conditions or personal injury.

⚠ CAUTION

Do not inflate the element without having a drum in place. Inflation of the element without a drum in place will result in permanent damage to the element components.

2.1 Mounting arrangements

2.1.1 Airflex VC grinding mill clutch applications are available in single-narrow, single-wide, dual-narrow and dual-wide mounting configurations. See Figure 4. The clutch configuration is determined by the motor horse-power and RPM, the allowable motor overload (per cent rated horsepower) for mill starting, the inertia of the mill and the charge, and the physical space available for the clutch. With the exception of single-narrow arrangements, all clutches can be supplied with axial locking devices.

2.2 Mounting considerations

2.2.1 Shaft alignment must be within the tolerances indicated in the Alignment section of this manual.

⚠ CAUTION

Operation with shaft misalignment exceeding the limits indicated in this manual will result in accelerated wear of the clutch components.

2.2.2 The element must be protected from contamination from oil, grease or excessive amounts of dust.

⚠ CAUTION

Oil or grease contamination will result in a reduction of developed torque. Excessive dust contamination may result in incomplete disengagement. Either of these conditions will result in clutch slippage and overheating.

⚠ CAUTION

All rotating equipment must be guarded to comply with applicable safety standards.

SINGLE NARROW & SINGLE WIDE

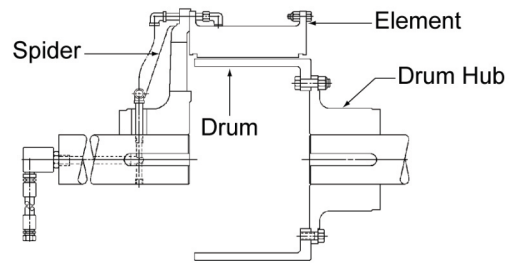

DUAL NARROW

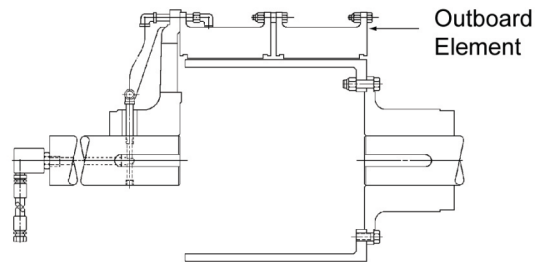

DUAL WIDE

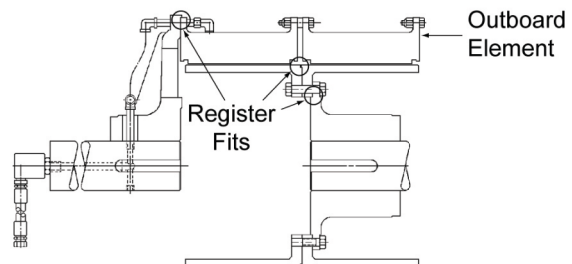

Figure 4

2.2.3 All mounting fasteners must be of the proper size and grade, and torqued to the appropriate value. See Table 1.

⚠ WARNING

Use only the proper grade and number of mounting fasteners. Using commercial grade fasteners (Grade 2) in place of Grade 8 fasteners (where called for) may result in failure under load, causing personal injury or equipment damage.

Airflex model VC Grinding mill clutches

Table 1. Fastener assembly torque

Size	Element to spider/side plate to rim	Torque	Drum to hub	Torque
SN11.5VC500	3/8-16NC GR 2	D 15 (20)	1/2-13NC GR 2	D 38 (51)
SN14VC500	1/2-13NC GR 2	D 15 (20)	1/2-13NC GR 2	D 38 (51)
SN16VC600	1/2-13NC GR 2	D 38 (51)	3/4-10NC GR 2	L 93 (126)
SN20VC600	1/2-13NC GR 2	D 38 (51)	3/4-10NC GR 2	L 93 (126)
SN24VC650	5/8-11NC GR 2	D 77 (104)	3/4-10NC GR 2	L 93 (126)
SN28VC650	5/8-11NC GR 2	D 77 (104)	3/4-10NC GR 2	L 93 (126)
SN33VC650	3/4-10 NC GR 2	L 93 (126)	3/4-10NC GR 2	L 93 (126)
SN37VC650	3/4-10NC GR 2	L 93 (126)	3/4-10NC GR 2	L 93 (126)
SN42VC650	3/4-10NC GR 2	L 93 (126)	3/4-10NC GR 2	L 93 (126)
DN 11.5VC500	3/8-16NC GR 2	D 15 (20)	1/2-13NC GR 8	D 109 (148)
DN14VC500	1/2-13NC GR 8	D 87 (118)	1/2-13NC GR 2	D 38 (51)
DN16VC600	1/2-13NC GR 2	D 38 (51)	3/4-10NC GR 8	L 245 (332)
DN20VC600	1/2-13NC GR 8	D 87 (118)	3/4-10NC GR 8	L 211 (286)
DN24VC650	5/8-11NC GR 2	D 77 (104)	3/4-10NC GR 2	L 93 (126)
DN28VC650	5/8-11NC GR 2	D 77 (104)	3/4-10NC GR 2	L 93 (126)
DN33VC650	3/4-10NC GR 2	L 93 (126)	3/4-10NC GR 2	L 93 (126)
DN37VC650	3/4-10NC GR 2	L 93 (126)	3/4-10NC GR 2	L 93 (126)
DN42VC650	3/4-10NC GR 2	L 93 (126)	3/4-10NC GR 2	L 93 (126)
SW 14VC1000	1/2-13NC GR 2	D 38 (51)	1/2-13NC GR 8	L 109 (148)
SW 16VC1000	1/2-13NC GR 2	D 38 (51)	3/4-10NC GR 2	L 93 (126)
SW 20VC1000	1/2-13NC GR 2	D 38 (51)	3/4-10NC GR 2	L 93 (126)
SW24VC1000	5/8-11NC GR 2	D 77 (104)	3/4-10NC GR 2	L 93 (126)
SW28VC1000	5/8-11NC GR 2	D 77 (104)	3/4-10NC GR 2	L 93 (126)
SW32VC1000	5/8-11NC GR 2	D 77 (104)	3/4-10NC GR 2	L 93 (126)
SW38VC1200	3/4-10NC GR 2	L 93 (126)	3/4-10NC GR 2	L 93 (126)
SW42VC1200	3/4-10NC GR 2	L 93 (126)	3/4-10NC GR 2	L 93 (126)
SW46VC1200	7/8-9NC GR 2	L 109 (148)	1-8NC GR 2	L 163 (221)
SW52VC1200	7/8-9NC GR 2	L 109 (148)	1-8NC GR 2	L 163 (221)
SW51VC1600	7/8-9NC GR 2	L 109 (148)	1-8NC GR 2	L 163 (221)
SW60VC1600	1-8NC GR 2	L 163 (221)	1 1/2-6NC GR 2	L 566 (767)
SW66VC1600	1 1/4-7NC GR 2	L 325 (441)	1 1/2-6NC GR 2	L 566 (767)
DW 16VC1000	1/2-13NC GR 8	D 87 (118)	3/4-10NC GR 8	L 245 (332)
DW20VC1000	1/2-13NC GR 8	D 87 (118)	3/4-10NC GR 8	L 245 (332)
DW24VC1000	5/8-11NC GR 8	D 174 (236)	3/4-10NC GR 8	L 245 (332)
DW28VC1000	5/8-11NC GR 8	D 174 (236)	3/4-10NC GR 8	L 245 (332)
DW32VC1000	5/8-11NC GR 8	D 174 (236)	3/4-10NC GR 8	L 245 (332)
DW38VC1200	3/4-10NC GR 8	L 245 (332)	3/4-10NC GR 8	L 245 (332)
DW42VC1200	3/4-10NC GR 8	L 245 (332)	3/4-10NC GR 8	L 245 (332)
DW46VC1200	7/8-9NC GR 2	L 109 (148)	1-8NC GR 8	L 510 (692)
DW52VC1200	7/8-9NC GR 2	L 109 (148)	1-8NC GR 8	L 510 (692)
DW51VC1600	7/8-9NC GR 2	L 163 (221)	1-8NC GR 8	L 510 (692)
DW60VC1600	1-8NC GR 2	L 190 (258)	1 1/2-6NC GR 2	L 650 (881)
DW66VC1600	1 1/4-7NC GR 2	L 380 (515)	1 1/2-6NC GR 2	L 650 (881)
DW76VC1600	1 1/4-7NC GR 2	L 380 (515)	1 1/2-6NC GR 2	L 650 (881)
DW76VC2000	1 1/4-7NC GR 2	L 380 (515)	1 1/2-6NC GR 2	L 650 (881)

SN = SINGLE NARROW SW = SINGLE WIDE DN = DUAL NARROW DW = DUAL WIDE
 L = LUBED TORQUE - FT.LB.(Nm) (30wt. Motor oil or anti-seize) D = DRY TORQUE - FT.LB.(Nm)

Hex sizes (in.)

Size	Bolt	Nut	Size	Bolt	Nut	Size	Bolt	Nut
3/8NC	9/16	9/16	3/4NC	1-1/8	1-1/16	1-1/4NC	1-7/8	1-13/16
1/2NC	3/4	3/4	7/8NC	1-5/16	1-1/4	1-1/2NC	2-1/4	2-3/16
5/8NC	15/16	15/16	1NC	1-1/2	1-7/16	-	-	-

Airflex model VC Grinding mill clutches

2.3 Mounting spider and drum hub

- 2.3.1 The spider and drum hub are bored for a press fit onto their respective shafts. The interference is approximately 0.0005 inch per inch (0.0127mm/mm) of shaft diameter.
- 2.3.2 Ensure the shaft is dean and free of nicks or burrs and check the shaft and bore diameters for proper fit. Tap the key into the keyway, making sure it bottoms, and apply a light coat of anti-seizing compound to the shaft and key.
- 2.3.3 Heat the drum hub or spider uniformly to 250°F (121°C) to expand the bore

CAUTION

It is recommended the drum hub or spider be heated in oil or an oven; however, torches may be used. Use several with "rosebud" (broad-flame) tips and keep them moving to avoid "hot spots." Check bore temperature frequently to avoid overheating.

- 2.3.4 Slide the heated drum hub or spider onto the shaft. Hold in position and allow to cool.

2.4 Shaft alignment

Parallel alignment tolerance (offset):

Not to exceed 0.010 inch (0.254 mm)
Total Indicator Reading (0.005 inch (0.127mm) maximum off- set).

Angular alignment tolerance (gap):

Not to exceed 0.0005 inch per inch (0.0127mm/ mm) diameter at which readings are taken ("D" on Figure 5).

Note : The alignment procedure described below has been used successfully on many VC grinding mill clutch applications. Other procedures, of course, may be used; however, the alignment tolerances are the same regardless of the technique used.

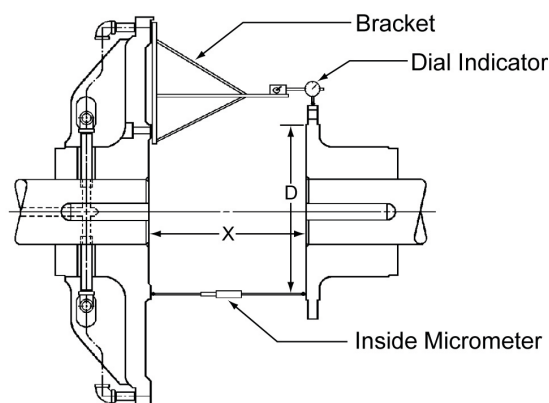

Figure 5

- 2.4.1 Foundations must be set so distance "X," shown on Figure 5 (or the appropriate drawing for non-standard applications), is established. If the clutch is mounted on a shaft having plain bearings, make sure the shaft is centered within the bearings when establishing the "X" dimension. Refer to Table 2 for appropriate "X" dimensions.

Note: It is presumed that one of the shafts has been properly located and anchored. When setting and aligning the grinding mill drive components, always work from the pinion back to the motor.

- 2.4.2 Fabricate a rigid bracket for supporting a dial indicator and attach to the spider shown on Figure 5 .
- 2.4.3 Thoroughly clean the flange O.D. and the face of the drum hub where alignment readings are to be taken.

Table 2. "X" Dimensions (Fig 5)

Size	"X" In. (mm)	Size	"X" In. (mm)	Size	"X" In. (mm)	Size	"X" In. (mm)
SN11.5VC500	6.750 (171.5)	DN 11.5VC500	13.375 (339.7)	SW14VC1000	11.875 (301.6)	-	-
SN14VC500	6.812 (173.0)	DN14VC500	13.438 (341.3)	SW16VC1000	11.875 (301.6)	DW16VC1000	12.750 (323.9)
SN16VC600	8.062 (204.8)	DN16VC600	15.938 (404.8)	SW20VC1000	11.875 (301.6)	DW20VC1000	12.750 (323.9)
SN20VC600	8.062 (204.8)	DN20VC600	15.938 (404.8)	SW24VC1000	11.875 (301.6)	DW24VC1000	12.750 (323.9)
SN24VC650	8.562 (217.5)	DN24VC650	16.688 (423.9)	SW28VC1000	11.875 (301.6)	DW28VC1000	12.750 (323.9)
SN28VC650	8.562 (217.5)	DN28VC650	16.688 (423.9)	SW32VC1000	11.938 (303.2)	DW32VC1000	12.812 (325.4)
SN33VC650	8.562 (217.5)	DN33VC650	16.750 (425.5)	SW38VC1200	14.125 (356.7)	DW38VC1200	15.000 (381.0)
SN37VC650	8.562 (217.5)	DN37VC650	16.750 (425.5)	SW42VC1200	14.125 (358.7)	DW42VC1200	15.125 (384.2)
SN42VC650	8.562 (217.5)	DN42VC650	16.750 (425.5)	SW46VC1200	14.125 (358.7)	DW46VC1200	15.250 (387.4)
-	-	-	-	SW52VC1200	14.625 (371.5)	DW52VC1200	15.750 (400.0)
-	-	-	-	SW51VC1600	18.875 (479.4)	DW51VC1600	20.000 (508.0)
-	-	-	-	SW60VC1600	18.750 (476.31)	DW60VC1600	20.375 (517.5)
-	-	-	-	SW66VC1600	20.500 (520.7)	DW66VC1600	22.000 (558.8)
-	-	-	-	SW76VC1600	Contact factory	DW76VC1600	20.375 (517.5)
-	-	-	-	SW76VC2000	Contact factory	DW76VC2000	24.374 (619.1)

- 2.4.4 Rotate the spider and take parallel alignment readings off the drum hub flange O.D. If both shafts can be rotated together, the alignment readings are less influenced by any surface irregularities

Note: On reverse-mounted clutches where only one shaft can be rotated, the indicator is attached to the drum hub and readings are taken off of the spider O.D.

CAUTION

When recording parallel alignment readings, "sag" of the indicator/indicator bracket must be accounted for.

- 2.4.5 Angular alignment readings can be made by accurately measuring the gap between the spider and drum hub faces with an inside micrometer. If a dial indicator is used, make sure to monitor and correct for any axial movement of the shaft. To reduce the influence any surface irregularities may have on the angular alignment readings, index the spider 90 degrees after taking the initial set of readings. Take an additional set of readings and index the spider another 90 degrees. Continue in this manner until four sets of readings have been taken. For misalignment correction, use the average of the four readings at each position.

- 2.4.6 Shim and shift the base of the movable shaft to correct the misalignment. After tightening the base, recheck the alignment and correct if necessary. Make sure to check for a "soft foot" condition. Dowel or chock into position after satisfactory alignment has been achieved.

Note: On some applications, thermal growth of the mill or gear reducer (if present) may result in unacceptable shaft alignment in a running condition. It is always a good practice to make a "hot alignment" check and the shim if necessary.

2.5 Axial locking device adjustment

- 2.5.1 If the "X" dimension shown on Table 2 could not be achieved within +/- 0.250 inch (6.4mm), the axial locking device has a provision to accommodate this variation.

- 2.5.2 Position the motor shaft on its magnetic center and measure the gap between the faces of the drum hub and spider ("X" dimension on Table 2). The difference between this measured dimension and the value shown on Table 2 is the amount of correction to be made with adjustment of the axial locking device.

- 2.5.3 Referring to Figure 6 , the overall length of the axial locking device can be adjusted by relocating shims (11,16) from one side of a bearing to another.

- 2.5.3.1 Remove four hex head screws and lock washers (6,7) from the bearing housing (8) and adapter plate (1 or 9).

- 2.5.3.2 Remove the snap ring (2) from the bearing housing.
- 2.5.3.3 After ensuring the shaft (3) is clean and free of foreign matter, nicks or burrs in the area between the two bearing housings, slide the bearing housing assembly toward the opposite bearing housing assembly to expose the bearing/spacer assembly (10,11,16).
- 2.5.3.4 Remove the bearing locknut and lockwasher (13,14) from the shaft.
- 2.5.3.5 The assembled length of the axial locking device is established by the location of the bearings with respect to the shaft. The assembled length can therefore be adjusted by moving spacers from one side of the bearing to the other. Two thicknesses of spacers are included in each assembly (0.025 inch (0.6 mm) and 0.098 inch (2.5 mm)). After making the appropriate assembled length adjustment, reassemble, making sure the thinner spacers are against the bearing.
- 2.5.3.6 Tighten the locknut sufficiently to take up all axial clearance in the bearing/spacer/snap ring assembly.
- 2.5.3.7 Slide the housing back over the bearing and install the snap ring.
- 2.5.3.8 Secure and tighten the bearing housing to the adapter plate using four hex head screws and lockwashers. Tighten the screws to 35 ft.lb. (47Nm).

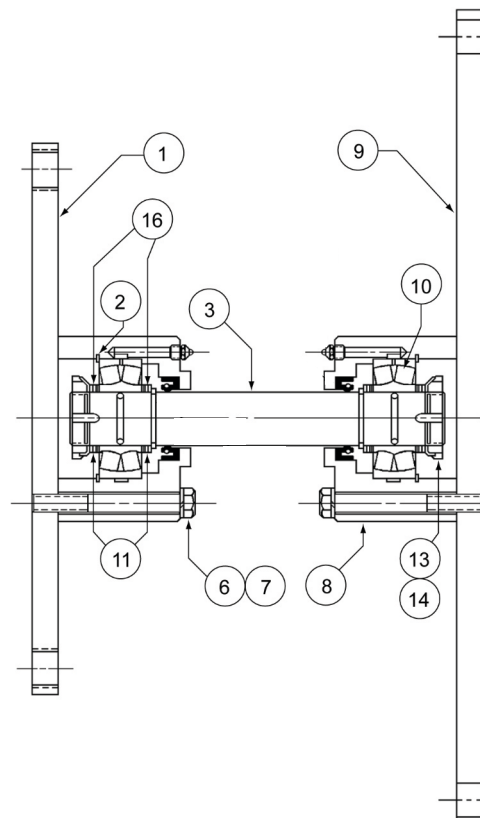

Figure 6

Airflex model VC Grinding mill clutches

- 2.5.3.9 After completing assembly, lubricate both bearings with No.2 EP grease.
- 2.6 Installation of element and drum (narrow, dual narrow and single wide)
- 2.6.1 Note the orientation of the drum flange with respect to the air connection(s) on the element and slide the drum into the element.
- 2.6.2 Attach the axial locking device (if required) to the drum flange with the appropriate screws and lockwashers. There are tapped holes in the drum flange to accept the screws.
- 2.6.3 Separate the shafts as far as the bearing clearances will allow and hoist the element/drum (axial locking device) into position. If an axial locking device is used, take special care when hoisting the element between the shafts. The axial locking device mounting plate binds easily against the spider face.
- 2.6.4 Attach the drum to the drum hub with the appropriate fasteners. See Table 1. Make sure the bore in the drum flange fully engages the pilot on the drum hub.
- 2.6.5 Install the air connection gaskets onto the air tubes. The metal backup washer is to be positioned toward the elbow (away from the spider). See Figure 7 .

Note: Some older elements use a flanged air connection tube and a thin gasket. See Table 3 . for correct part numbers.

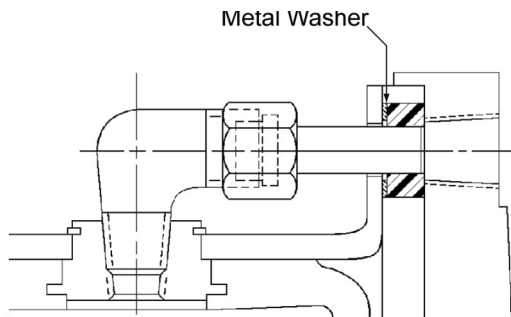

Figure 7

- 2.6.6 Align the element air connections with the passages in the spider and attach the element to the spider with the appropriate fasteners. See Table 1 . Make sure the element fully engages the register in the spider.
- 2.6.7 Attach the axial locking device (if required) mounting plate to the spider with the appropriate screws and lock washers. Rotate the motor shaft and push the spider towards the mill until the axial locking device mounting plate is flush against the spider face. Tighten the screws.

CAUTION

Do not attempt to pull the motor shaft back onto magnetic center by tightening the axial locking device mounting screws. To do so will damage the axial locking device.

- 2.7 Installation of element and drums (dual wide)
- 2.7.1 Separate the shafts as far as the bearing clearances will allow.
- 2.7.2 Attach the drum having the female register on the drum flange to the drum hub with short screws and lockwashers. There are tapped holes in the drum flange to accept the screws. Make sure the bore in the drum flange fully engages the pilot on the drum hub. See Figure 4.
- 2.7.3 Disassemble the dual element into two halves and, noting the orientation of the air connections, place the element onto the drum installed in 2.7.2.
- 2.7.4 Noting the orientation of the flange on the remaining drum with respect to tie air connections on the remaining element, slide the drum into the element.
- 2.7.5 Attach the axial locking device (if required) to the flange of the remaining drum with the appropriate short screws and lockwashers. There are tapped holes in the drum to accept the screws.
- 2.7.6 Hoist the element/drum (axial locking device) into position, align the tapped holes in the drum having the male pilot with the tapped holes in the drum attached to the drum hub, and attach both drums to the drum hub with the appropriate fasteners. See Table 1. Make sure the male pilot fully engages the female register. If an axial locking device is used, take special care when hoisting the element between the shafts. The axial locking device mounting plate binds easily against the spider face.
- 2.7.7 Align the air connections and reassemble the element halves, making sure the spacers are in place between the elements. See Figure 8 .
- 2.7.8 Reassemble the air connection tubes. If an elbow has been removed, use a good quality pipe sealant on the threads. See Figure 8 .

Note: The elbow assemblies on the outboard element (farthest from the spider) use rubber compression sleeves. Make sure the sleeves are secure on the long air tubes.

2.79 Install the air connection gaskets onto the air tubes. The metal backup washer is to be positioned toward the elbow (away from the spider). See Figure 7 .

2.710 Align the element air connections with the corresponding passages in the spider and attach the element to the spider with the appropriate fasteners. See Table 1 . Make sure the element fully engages the register in the spider.

2.711 Attach the axial locking device mounting plate (if required) to the spider with the appropriate screws and lockwashers. Rotate the motor shaft and push the spider toward the mill until the axial locking device mounting plate is flush against the spider face. Tighten the screws.

CAUTION

Do not attempt to pull the motor shaft back onto magnetic center by tightening the axial locking device mounting screws. To do so will damage the axial locking device

Table 3. Air connections for VC Elements

Size	Old method		Current method	
	Air tube	Washer	Air tube	Washer
11.5VC500	201402	72 x 15	412178-02	412324-01
14VC500	201302	72 x 11	412178-03	412324-02
16VC600	201302	72 x 11	412178-03	412324-02
20VC600	201302	72 x 11	412178-03	412324-02
24VC650	201286	72 x 12	412178-05	412324-03
28VC650	201286	72 x 12	412178-05	412324-03
33VC650	201284	72 x 13	412178-06	412324-04
37VC650	201284	72 x 13	412178-06	412324-04
42VC650	201284	72 x 13	412178-06	412324-04
14VC1000	201302	72 x 11	412178-03	412324-02
16VC1000	202408	72 x 11	412178-03	412324-02
20VC1000	201302	72 x 11	412178-03	412324-02
24VC1000	201286	72 x 12	412178-05	412324-03
28VC1000	201286	72 x 12	412178-05	412324-03
32VC1000	201286	72 x 12	412178-05	412324-03
38VC1200	201284	72 x 13	412178-06	412324-04
42VC1200	201284	72 x 13	412178-06	412324-04
46VC1200	202081	72 x 13	412178-07	412324-04
52VC1200	202751	72 x 14	412178-08	412324-05
51VC1600	304213	72 x 14	412178-09	412324-05
60VC1600	304213	72 x 14	412178-18	412324-06
66VC1600	-	-	412178-04	412324-06
76VC1600	-	-	412178-04	412324-06
76VC2000	-	-	412178-04	412324-06

Airflex model VC Grinding mill clutches

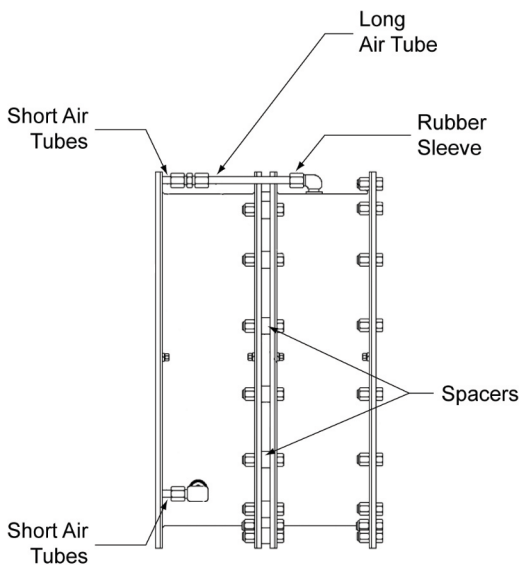

Figure 8

2.8 Air control system

2.8.1 A typical air control system is shown on Figure 9. Since operating characteristics vary from one grinding mill to another, following are some general guidelines for installing the air controls.

2.8.1.1 The air receiver tank must be located as close to the clutch as possible (the tank should be located within 15 feet of the solenoid valve, and solenoid valve should be within five feet from the rotor seal) for consistent clutch response.

2.8.1.2 Use full size piping and valves consistent with the rotor seal size and keep the number of elbows to a minimum.

2.8.1.3 Use poppet-type solenoid valves. Spool valves are not recommended.

2.8.1.4 An air line lubricator is not required for the clutch element; however, if one is used, it must be a nonadjustable, mist-type.

2.8.1.5 Make sure the flow control valve is installed with free flow (indicated by an arrow on the valve body) away from the clutch (free flow to exhaust).

2.8.1.6 The final connection to the rotor seal MUST be made with flexible hose and place no radial load upon the rotor seal. Also, if the rotor seal is mounted onto the end of a motor shaft, an insulating coupling must be installed between the piping and the rotor seal.

CAUTION

Do not use rigid pipe at the connection to the rotor seal. Rigid piping will result in excessive loads on the rotor seal bearings, shortening life.

2.9 Electrical controls

2.9.1 The basic Airflex grinding mill clutch control is shown on Figure 10. This control provides run, inch and timed inch features only. Timed inch creates a delay between successive clutch engagements when spotting the mill to prevent clutch overheating and damage. Other control features, such as clutch slip detection, can be provided as required. Contact Airflex for details.

Airflex standard air tank group

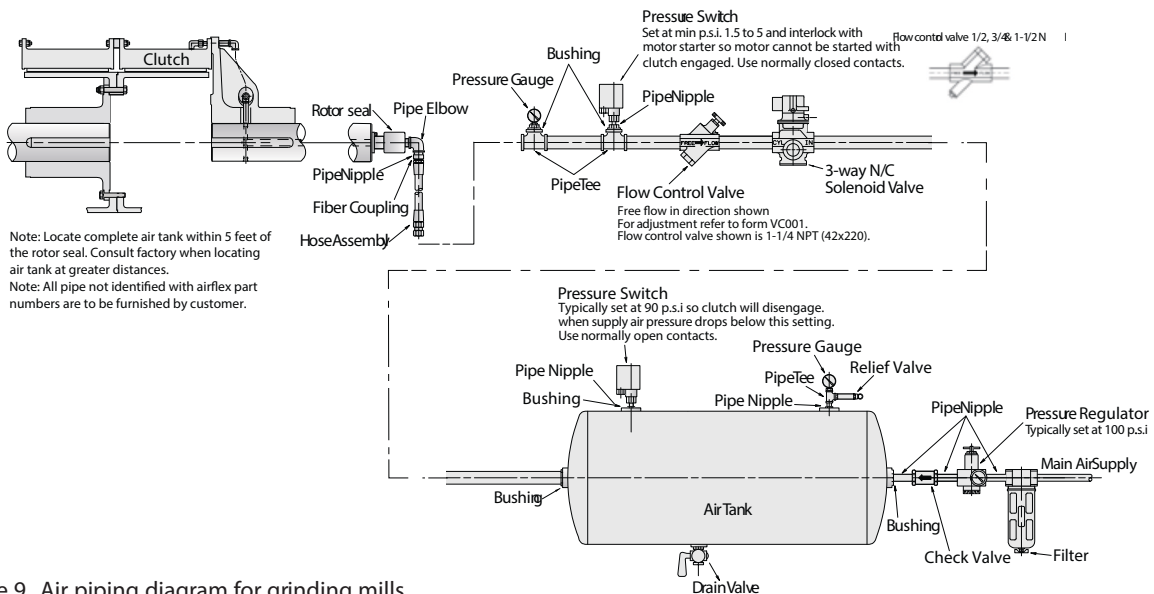

Figure 9. Air piping diagram for grinding mills

Airflex model VC Grinding mill clutches

Table 4. Air tank groups

Single	Dual	Single	Dual		Old	Old	New	New
Narrow	Narrow	Wide	Wide	Pipe size	P/N	LA drawing	P/N	LA drawing
Standard								
11.5 to 16	-	-	-	1/2"	105248	LA-10720	n/a	n/a
20 to 28	11.5 to 20	14 to 20	-	1/2"	105248A	LA-10721	108702	LA-11702
33 to 42	24 to 28	24 to 28	16	3/4"	105248B	LA-10722	108703	LA-11703
-	33 to 37	32	20 to 24	1"	105248C	LA-10723	108704	LA-11704
-	42	38 to 42	28 to 32	1 1/4"	105248D	LA-10724	108705	LA-11705
-	-	46	38	1 1/2"	105248E	LA-10725	108706	LA-11706
-	-	51 to 66	42 to 46	1 1/2"	105248AP	LA-10726	108707	LA-11707
-	-	76	51 to 66	1 1/2"	105248AQ	LA-10727	108708	LA-11708
-	-	-	76 (1600 & 2000)	2"	n/a	LA-10728	108709	LA-11709
Premium								
20 to 28	11.5 to 20	14 to 20	-	1/2"	108248A	LA-10701	108602	LA-11602
33 to 42	24 to 28	24 to 28	16	3/4"	108248B	LA-10702	108603	LA-11603
-	33 to 37	32	20 to 24	1"	108248C	LA-10703	108604	LA-11604
-	42	38 to 42	28 to 32	1 1/4"	108248D	LA-10704	108605	LA-11605
-	-	46	38	1 1/2"	108248E	LA-10705	108606	LA-11606
-	-	51 to 66	42 to 46	1 1/2"	108248F	LA-10706	108607	LA-11607
-	-	76	51 to 66	1 1/2"	108248G	LA-10707	108608	LA-11608
-	-	-	76 (1600 & 2000)	2"	108248H	LA-10708	108609	LA-11609
Super premium								
20 to 28	11.5 to 20	14 to 20	-	1/2"	108094A	LA-11191		
33 to 42	24 to 28	24 to 28	16	3/4"	108094B	LA-11192		
-	33 to 37	32	20 to 24	1"	108094C	LA-11193		
-	42	38 to 42	28 to 32	1 1/4"	108094D	LA-11194	N/A	N/A
-	-	46	38	1 1/2"	108094E	LA-11195	Use premium	Use premium
-	-	51 to 66	42 to 46	1 1/2"	108094F	LA-11196		
-	-	76	51 to 66	1 1/2"	108094G	LA-11197		
-	-	-	76 (1600 & 2000)	2"	108094H	LA-11198		
-	-	-	Quadramatic 66 and 76	2"	108094GS	LA-11197-11	No change	No change

Airflex model VC Grinding mill clutches

: LA-9811

Figure 10 Wiring diagram for grinding mill control panel reference

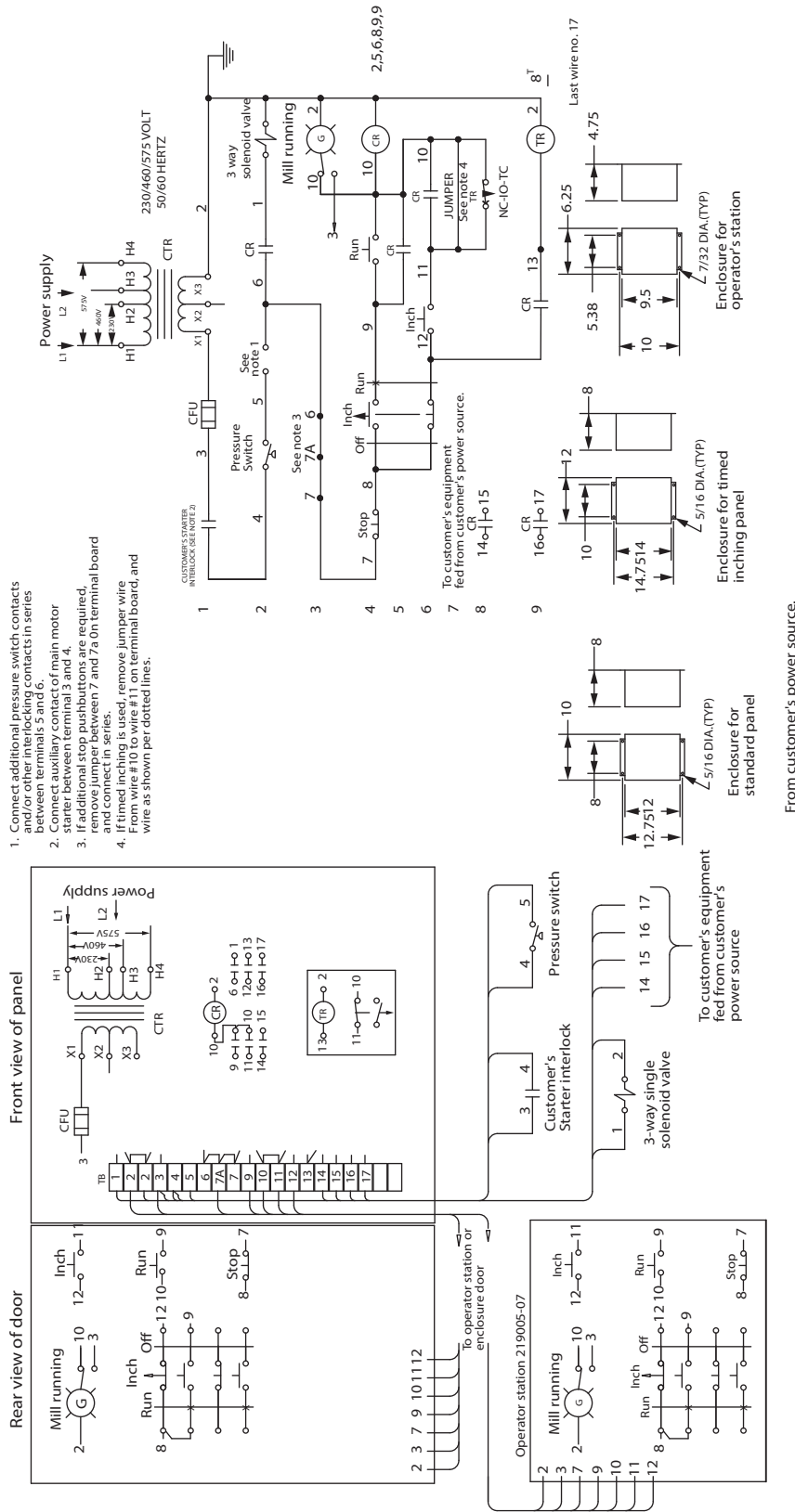

Electrical control components	
Panel no.	Remarks
209811-01	Std. Panel W/pb's,selector/light in door
105448	Std. Panel W/219005-07 operator station
209811-03	Timed inching panel W/pb's,selector/light in door
105449	Timed inching panel W/219005-07 operator station
209811-05	Std. Panel(similar to 209811-02 except nema 4 ENCL.)
209811-15	Std. Panel W/extra terminals and nema 12 ENCL.
209811-23	Timed panel w/219005-18 station, NEMA 4 ENCL.
209811-24	Timed panel(sim to 209811-03 except NEMA 4)
209811-89	Timed panel(sim to 209811-03 except NEMA 4)/GE comp.
209811-93	Std. Panel(sim to 209811-01 except NEMA 4)

Equipment list		
SYM	Description	Airflex part no.
CTR	Transformer	G.E. 9T58B65
CR	Control relay	C.H.G26MR60A
TR	Timing relay	C.H.D80ND1A
1SS	Off-inch-run	C.H.10250T-152-2-7-T1-T1
1PB	Run	C.H.10250T-30B-536
2PB	Inch	C.H.10250T-30B-518
3PB	Stop	C.H.10250T-31R-536
CFU	Fuse	BUSS FRN 1.6
G	Light	C.H.10250T-74G-536
TB	Terminal board	G.E. CR151-D21720

Table 5. Maximum safe operating speeds

Size (Narrow)	Max. (RPM)	Size (Narrow)	Max. (RPM)	Size (Wide)	Max. (RPM)	Size (Wide)	Max. RPM
11.5VC500	1800	28VC650	1000	14VC1000	1800	42VC1200	670
14VC500	1500	33VC650	900	16VC1000	1400	46VC1200	600
16VC600	1400	35VC650	900	20VC1000	1300	52VC1200	550
20VC600	1200	37VC650	800	24VC1000	1250	51VC1600	550
24VC650	1050	42VC650	800	28VC1000	1100	60VC1600	520
-	-	-	-	32VC1000	1050	66VC1600	480
-	-	-	-	38VC1200	740	76VC1600	275
-	-	-	-	-	-	76VC2000	275

3.0 Operation

WARNING

Exceeding the operating limits described in this section may result in personal injury or equipment damage.

3.1 Torque, RPM and pressure limits

3.1.1 The developed torque is directly proportional to the applied air pressure. If the developed torque seems inadequate, check for oil, grease or dust contamination.

CAUTION

Maximum applied air pressure is 125 psig (8.5 bar). Operation at pressures exceeding 125 psig may result in damage to the clutch element. Airflex grinding mill clutches typically require only 100 psig (6.8 bar) operating pressure.

CAUTION

The non-asbestos friction material used in Airflex VC units may not develop rated torque initially, as a short "Wearin" period is required. It is very important that the first few mill starts be monitored to prevent excessive heat generation from slippage.

3.1.2 Maximum safe operating speeds are shown on Table 5.

DANGER

Do not exceed the operating speeds shown on Table 5. Operation at speeds greater than allowable will result in permanent damage to the clutch element, personal injury or death.

3.2 Control component adjustment

The following section gives "typical" component settings only. Since operating characteristics vary from one grinding mill to the next, absolute values cannot be given. The settings described below offer a good "starting point" to achieve satisfactory mill acceleration and motor overload - some "fine tuning" will probably be required.

3.2.1 Set the pressure switch (5) located on the air receiver tank to open at 90 psig (6.1 bar) falling. Use normally open contacts and wire in series with the solenoid valve coil. This pressure switch is used to disengage the clutch if operating pressure falls below 90 psig (6.1 bar), or to prevent clutch engagement if operating pressure is below 90 psig (6.1 bar).

3.2.2 Set the pressure switch (13) located in the air supply line to the clutch to open at approximately 5 psig (0.3 bar). Use normally closed contacts and wire into the motor starter interlock circuit. The purpose of this pressure switch is to prevent starting the motor with the clutch engaged.

3.2.3 Set the pressure regulator (3) to 100 psig (6.8 bar). This is the nominal starting air pressure for the mill.

3.2.4 With the motor "off" manually trip the solenoid valve and note the time elapsed for the pressure gauge (7) to register full tank pressure.

3.2.5 Repeat the above procedure while adjusting the flow control valve (11) to supply a pressure rate of approximately 20 psig/sec. (1.4 bar/sec.). Due to the non-linearity of the pressure-time curve (See Figure 11), it will be easier to use a reduced value to set the flow control valve. For example, if the tank pressure is 100 psig (6.8 bar), to obtain a flow rate of 20 psig/sec. (1.4 bar/sec.), time the pressure build up to 80 psig (5.4 bar) and adjust the flow control valve to deliver this pressure in 4 seconds, which, for all practical purposes, would equate to the desired 20 psig/sec. (1.4 bar/sec.).

Curve "rolls off" as full pressure is approached

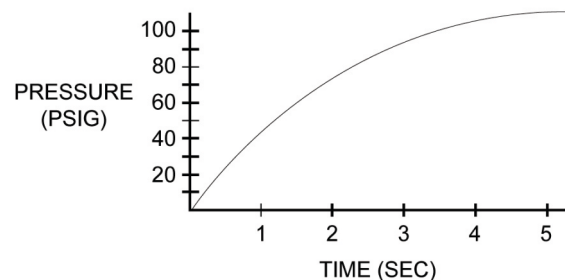

Figure 11

Airflex model VC Grinding mill clutches

- 3.2.5.1 The flow rate is increased by turning the flow control valve adjusting screw clockwise on the 3/4", 1" and 1-1/4" valves, and counter-clockwise on the 1-1/2" valve. The 1-1/2" valve has wrench flats on the adjusting screw. The 1-1/4" valve has a knurled adjusting knob. The 3/4" and 1" valves have slotted adjusting screws.
- 3.2.6 Manually engage the clutch several times to verify the flow control valve setting. Also, confirm operation of the pressure switches at this time.
- 3.2.7 Check all other interlocks that affect the starting of the mill and remove any jumpers that may have been installed.

CAUTION

The flow rate described typically will result in a 4-7 second mill acceleration time (timed from the instant the clutch shoes make contact with the drum to the instant the clutch locks up); however, since operating characteristics vary from mill to mill, the mill acceleration at the above flow setting may be greater or less than the allowable 4-7 second range.

CAUTION

The non-asbestos friction material used on Airflex VC clutches may not develop rated torque initially, as a short "wear-in" period is required. It is very important that the first few mill starts be monitored closely to prevent damage to the clutch components.

- 3.2.8 Start the motor and engage the clutch, noting the mill acceleration time. Abort the start if the clutch slips for more than seven seconds!
- 3.2.9 Disengage the clutch (if the start has not been aborted) and allow the drum(s) to cool to room temperature. Make the appropriate adjustment to the flow control valve if the mill acceleration fell outside of the 4-7 second range and retry. Repeat until the desired acceleration time has been achieved.

Note: If the motor overload is beyond allowable limits during the start (typically the result of too high operating pressure), reduce the operating pressure and increase the flow rate. If the motor is sized correctly for the mill load conditions, the overload on the motor is directly proportional to the applied air pressure - not the flow rate.

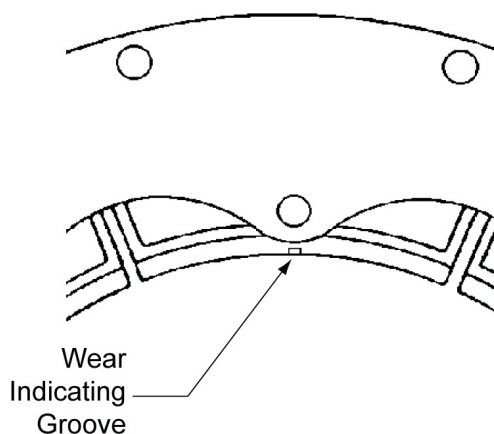

Figure 12

4.0 Maintenance

WARNING

Only qualified personnel should maintain and repair these units. Faulty workmanship may result in personal injury or equipment damage.

CAUTION

When replacing clutch components, use only genuine, Airflex replacement parts. Use of replacement material which is not of Airflex origin will void all warranties.

- 4.1 Periodic inspection
 - 4.1.1 The following items may be inspected without disassembly of the clutch:
 - 4.1.1.1 Friction shoe assembly lining wear- Check the lining thickness and compare to the values shown on Table 6. If the linings have worn to minimum allowable thickness or less, they must be replaced as a complete set.

Table 6. Friction material thickness

Narrow series		
Element size	Min. allowable lining thickness, inch (mm)	Original lining thickness, inch (mm)
11.5VC500 thru 20VC600	0.15 (3.8)	0.33 (8.4)
24VC650 thru 28VC650	0.15 (3.8)	0.45 (11.4)
33VC650 thru 42VC650	0.28 (7.1)	0.58 (14.7)
Wide series		
14VC1000 thru 20VC1000	0.15 (3.8)	0.33 (8.4)
24VC1000 thru 28VC1000	0.15 (3.8)	0.45 (11.4)
32VC1000 thru 42VC1200	0.38 (9.5)	0.58 (14.7)
46VC1200 thru 52VC1200	0.38 (9.5)	0.69 (17.5)
51VC1600 thru 76VC2000	0.30 (7.6)	0.67 (17.0)

CAUTION

Operation with friction material worn to less than minimum allowable thickness will result in damage to the drum.

Note: A wear indicating groove See Figure 12 is provided on each end of the friction block. The maximum wear point, which coincides with the values shown on Table 6, is at the bottom of the groove.

- 4.1.1.2 Contamination of shoes or drum - Oil or grease contamination will reduce the developed torque of the clutch. Disassembly will be required to clean any oil or grease buildup. In extremely dusty environments, dust may accumulate in the backing plate cavities to the point where the friction shoes will not properly retract. Dust accumulations may be vacuumed out of the cavities.

CAUTION

Do not attempt to use a solvent to remove oil or grease without first removing the element. While squirting a solvent into an installed clutch may improve performance temporarily, a fire hazard exists from the heat generated during slippage

CAUTION

Do not use compressed air to blow dust accumulations out of the backing plates. Although the friction material does not contain asbestos, the dust created as the friction material wears, along with the dust from the operating environment, may irritate the respiratory system.

- 4.1.1.3 Air control components - Check for proper adjustment of the air control components. Make sure the safety pressure switches are set correctly and are functioning properly. Repair any air leaks as discovered.
- 4.1.2 Partial or complete disassembly is required to inspect the following items:
 - 4.1.2.1 Drum diameter wear - Check the O.D. of the drum and compare to the values shown on Table 7. Minor heat-checking may be removed by machining the drum O.D. If the drum has been subjected to excessive heat, the open end may flare out, giving the impression that the drum has not worn. It is therefore important to check the diameter at several locations across the face.

CAUTION

Operation of the clutch on a drum that has worn, or has been machined, to less than minimum allowable diameter will result in damage to the element components.

- 4.1.2.2 Air actuating tube - Check that the tube has not been damaged by excessive heat. If any portion of the tube is hard or charred, the tube must be replaced. Check for any blisters, which would indicate ply separation. A tube in this condition must also be replaced.
- 4.1.2.3 Friction shoe lining wear - If the linings are glazed, they may be lightly sanded to remove the glazing providing they do not contain asbestos

WARNING

Clean the edge of the lining and note the presence of a blue stripe and a white stripe along with brass flakes in the friction material. If the above exists, the linings contain asbestos. Using the appropriate precautions for working with asbestos, remove the linings and dispose of properly. **DO NOT ATTEMPT TO SAND FRICTION MATERIAL CONTAINING ASBESTOS.**

CAUTION

When working with any friction material, regardless of whether or not it contains asbestos, always wear approved safety equipment. Material containing asbestos.

Airflex model VC Grinding mill clutches

- 4.1.2.4 Uneven friction lining wear - Tapered wear across the friction surface typically indicates a worn drum and/or misalignment. If two or more adjacent shoes are worn on one end only, the air actuating tube has most likely developed a ply separation at that location.
- 4.1.2.5 Backing plate wear - Wear on the ends of the backing plates from bearing against the side plates is indicative of misalignment or thrusting. If wear is on one end only, and uniform for all backing plates, a worn drum may be causing the shoes to thrust as the element engages. If wear exists on both ends of all of the backing plates, excessive misalignment is probably the cause. Slight notching in the torque bar cavity is normal; however, if the notching occurs in a short amount of time, check shaft alignment. If both walls in the torque bar cavity are notched, there may be a significant vibration (torsional) problem.

Table 7. Drum wear limits

Narrow series	
Element size	Max. allowable wear on drum diameter* inch (mm)
11.5VC500 thru 16VC600	0.09 (2)
20VC600 thru 24VC650	0.12 (3)
28VC650	0.19 (5)
33VC656 thru 42VC650	0.19 (5)
Wide series	
14VC1000 thru 16VC1000	0.09 (2)
20VC1000 thru 24VC1000	0.13 (3)
28VC1000	0.19 (5)
32VC1000 thru 38VC1200	0.19 (5)
42VC1200 thru 46VC1200	0.25 (6)
52VC1600 thru 76VC2000	0.25 (6)

* Note: The number preceding the letters "VC" in the element size designates the original drum diameter in inches. Example: 16VC600 - Original drum diameter = 16.00 inches (406 mm). Minimum allowable drum diameter is: 16 inch (406 mm) - 0.09 inch (2 mm) = 15.91 inch (404 mm).

- 4.1.2.6 Release springs and torque bars - Excessive wear at the ends of the torque bars where the release springs make contact indicates excessive parallel mis- alignment.
- 4.1.2.7 Side plates - Any wear on the backing plates will also be reflected as elongation of the torque bar holes in the side plates.
- 4.1.2.8 Contamination of friction shoes - Mild oil or grease contamination may be removed with a solvent. Linings which have become saturated must be replaced. Also, linings that have been charred from excessive heat must be replaced.

CAUTION

When using any solvent, always follow the appropriate safety precautions.

- 4.1.2.9 Excessive dust accumulation - If dust becomes packed in the backing plate cavities, a pressurized enclosure should be considered. Excessive accumulations will prevent complete shoe retraction.

4.2 Removal of element assembly and drum (narrow, dual narrow and single wide)

WARNING

Prior to removal of the clutch, make sure the mill is in, and will remain in, a safe condition.

- 4.2.1 Match mark the element to the spider and the drum to the drum hub.
- 4.2.2 Disconnect the element from the spider and allow it to rest on the drum.
- 4.2.3 Disconnect the axial locking device (if used) from the spider and separate the shafts as far as the bearings will allow.
- 4.2.4 Connect an overhead support to the element and apply enough tension to support the weight of the element and drum.
- 4.2.5 Remove the fasteners attaching the drum to the drum hub and hoist the element/drum out from between the shafts. If an axial locking device is used, take special care when hoisting the element/drum from between the shafts, as the axial locking device mounting plate binds easily against the spider face.

CAUTION

Use extreme care when disconnecting the drum from the hub. Shear points exist at the mounting holes.

- 4.3 Removal of element assemblies and drums (dual wide)
- 4.3.1 Match mark the element assemblies to each other and to the spider. Also, match mark the drums to each other and to the drum hub.
- 4.3.2 Disconnect the dual element from the spider and allow it to rest on the drums. Remove the air connection tubes.
- 4.3.3 Remove the fasteners and spacers attaching the element halves together.
- 4.3.4 Disconnect the axial locking device (if used) from the spider and separate the shafts as far as the bearings will allow.
- 4.3.5 Attach an overhead support to the spider-side element and apply enough tension to support the weight of the element half and one of the drums.
- 4.3.6 Remove the through bolts and nuts attaching the drums to the drum hub. Do not remove the short screws and lockwashers which hold the female drum onto the drum HUB. Carefully hoist the spider-side element and drum out from between the shafts. If an axial locking device is used, take special care when hoisting the

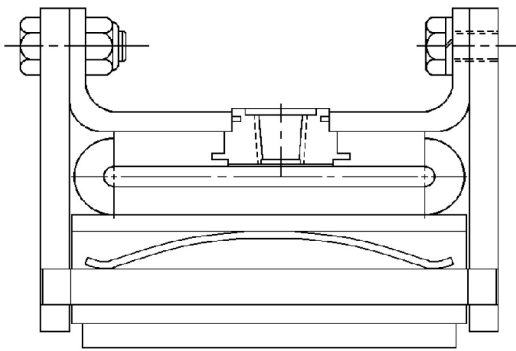

Snap ring and counterbore eliminated

11.5VC500	24VC650	42VC650	24VC1000
14VC500	28VC650	14VC1000	28VC1000
16VC600	33VC650	16VC1000	32VC1000
20VC600	37VC650	20VC1000	

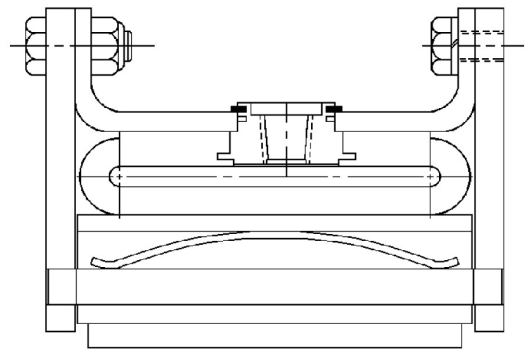

Counterbore eliminated and second snap ring groove added

38VC1200	46VC1200	51VC1600
42VC1200	52VC1200	60VC1600
		66VC1600

Figure 13

element/ drum from between the shafts, as the axial locking device mounting plate binds easily against the face of the spider.

- 4.3.7 Attach an overhead support to the remaining element and apply enough tension to support the weight of the element and drum.
- 4.3.8 Remove the short screws and lockwashers holding the drum onto the drum hub and carefully hoist the element and drum out from between the shafts.

CAUTION

Use extreme care when disconnecting the drums from the drum hub. Shear points exist at the mounting holes.

- 4.4 Removal of spider and drum hub
 - 4.4.1 Removal may not be necessary. Removal may only be needed access is needed to motor shaft, pinion shaft, or gearbox shaft.
 - 4.4.2 Puller holes are provided for removal. It will require heating along with the puller. When heating, use torches with rosebud tips. Heat uniformly to prevent hot spots and do not exceed 275 degrees F.
- 4.5 Disassembly of the element
 - 4.5.1 Lay the element flat on a clean work surface.
 - 4.5.2 Remove one of the side plates and inspect the surface that the friction shoes contact for any unusual wear patterns, especially look at the end scallops on the side plates and check for excessive wear.
 - 4.5.3 Remove the friction shoe assemblies, torque bars and release springs. If the torque bars and springs come out of the element with the friction shoe assemblies, carefully tap them out of the backing plate cavities. Note wear and replace as necessary.

CAUTION

Whenever the element is removed and disassembled, it is always good practice to replace the release springs.

- 4.5.4 Remove the air connection elbows and spiral snap rings which secure the air actuating tube to the rim. Smaller size elements do not use snap rings. Carefully remove the air actuating tube from the rim and thoroughly inspect. Replace if necessary.

Note: The snap rings may no longer be required on certain size elements. Also, rims manufactured before 1984 were counterbored at the tube valve hole to accept the snap ring. This counterbore has been eliminated, and a second snap ring groove has been added to the tube valve. See Figure 13 .

- 4.5.5 Remove the remaining side plate only if it is to be replaced.

4.6 Friction lining replacement

CAUTION

Use only genuine Airflex replacement parts. Use of replacement parts not of Airflex origin will void all warranties.

- 4.6.1 Make sure the torque bars and release springs have been removed from the backing plates.
- 4.6.2 For riveted friction shoe assemblies, drill the rivets with a 15/64 inch (6 mm) drill and tap the rivet body out. Larger elements have linings attached with flat head screws and locknuts. Airflex special wrench p/n 304572 will aid in holding the locknuts during removal. See Table 8 .

Airflex model VC Grinding mill clutches

4.6.3 Attach the new lining to the backing plate with new screws and locknuts or drive pin rivets (See Figure 14), as applicable. Work from the center of the friction lining out to the ends. The rivets are installed by driving the pin flush with the head.

Table 8. Friction shoe assembly fasteners

Drive pin rivets			
11.5VC500	24VC650	42VC650	24VC1000
14VC500	28VC650	14VC1000	28VC1000
16VC600	33VC650	16VC1000	
20VC600	37VC650	20VC1000	
Flat head screws* (brass) and locknuts			
32VC1000	46VC1200	60VC1600	76VC2000
38VC1200	52VC1200	66VC1600	
42VC1200	51VC1600	76VC1600	

* Screws are 3/8-16NC2 X 1.25 long flat head and should be tightened to 12 ft-lbs (dry)

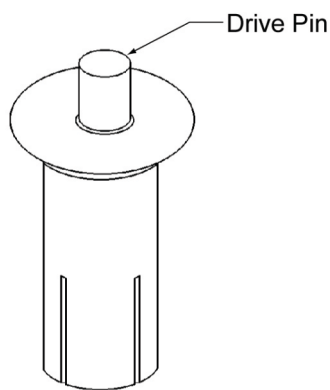

Figure 14

4.7 Assembly of the element

- 4.7.1 Make sure all of the components have been cleaned and any damaged or worn components have been repaired or replaced.
- 4.7.2 Assemble one of the side plates to the rim with cap screws and lockwashers. It is not necessary to install through bolts and locknuts at this time.
- 4.7.3 Lay the rim/side plate assembly on a clean, flat work surface, side plate down.
- 4.7.4 Carefully insert the air actuating tube into the rim. Push the valves on the tube through the corresponding holes in the rim and install the spiral snap rings (if applicable).
- 4.7.5 Place a torque bar in each mating hole in the side plate, slide a friction shoe assembly onto each torque bar and carefully tap a release spring (51VC1600, 60VC1600 and 66VC1600 elements have two release springs in each cavity) into place. Make sure the spring is positioned on the side of the torque bar opposite the friction lining. Also, the spring must contact the torque bar at two points, not one. See Figure 15 .

- 4.7.6 Lay the remaining side plate in position so the air connections and torque bar holes are properly aligned.
- 4.7.7 Carefully guide the torque bars into the corresponding holes in the side plate. It is often helpful to install four equally spaced screws and nuts through the rim and side plate to keep some tension on the side plate throughout this step.
- 4.7.8 Attach the side plate to the rim with cap screws and lockwashers, making sure all of the torque bars are seated in their side plate holes.
- 4.7.9 Note the orientation of the air connections and install the through bolts and locknuts where applicable.
- 4.7.10 Re-install the elbows using a good quality sealant on the pipe threads. Install the air connections on single narrow, dual narrow and single wide elements. Install only the short air connections (element closest to spider) on dual wide elements.
- 4.7.11 Re-install per 2.0.

5.0 Spare parts storage

- 5.1 Element assemblies
 - 5.1.1 Element assemblies must always be stored flat. Storage in the standing position may cause the rims to go out-of-round.
- 5.2 Drums
 - 5.2.1 Drums must be stored open end down. Similar to element assemblies, storage of a drum in the standing position will adversely affect roundness.
- 5.3 Air actuating tubes
 - 5.3.1 Air actuating tubes are shipped from the Airflex plant folded to conserve shipping space. Upon receipt, remove the tube from its container and allow it to assume its natural shape. Store in a cool, dry area, away from electrical equipment and ultraviolet light.

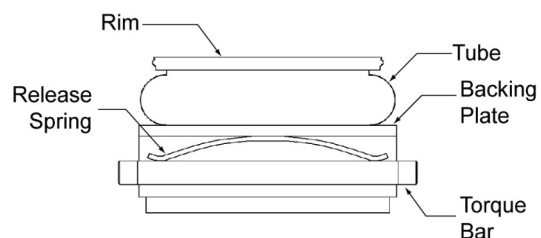

Figure 15

- 6.0 Ordering information/ technical assistance
 - 6.1 Equipment reference
 - 6.1.1 If possible locate the Airflex assembly drawing(s) and bill of material to insure the correct spare parts are used.
 - 6.1.2 In any correspondence regarding Airflex equipment, refer to the information on the product nameplate. If not available, note the drum diameter, air connection configuration, mounting arrangement or any other special features and call or write:

THE PART LISTS ON THE FOLLOWING PAGES APPLY TO STANDARD GRINDING MILL APPLICATIONS ONLY. HIGH-TORQUE APPLICATIONS AND CERTAIN RETROFIT APPLICATIONS WILL HAVE DIFFERENT COMPONENT PARTS. CONSULT THE FACTORY IF HAVING DIFFICULTY IDENTIFYING PART NUMBERS.

When repairing Airflex products, it is recommended to only use currently Danfoss AIRFLEX genuine product and an authorized DANFOSS AIRFLEX repair and rebuild facility. A listing of these may be found at "www.danfoss.com"

Airflex model VC Grinding mill clutches

7.0 Parts lists

7.1 Single narrow element assemblies

	Item																		
	1	2	3	4	5		6		7	10	11	12	13						
Element description	Part no. of complete element	Part no. 1 reqd.	Part no.	Part no.	Qty.	Part no.	Qty.	Part no.	Qty.	Part no.	Qty.	Part no.	Qty.	Part no.	Qty.				
11.5VC500	Minus side conn. Side conn.	403089	403090	-	-	131 X 11	2	131 X 20	2	412178-02	2	412324-01	2	414576 8 Req'd	414575 8 Req'd	130 X 72 48 Req'd	412123	201372 8 Req'd	201373 8 Req'd
14VC500	Minus side conn. Side conn.	406273	406274	-	-	92 X 6	2	87 X 12	2	412178-03	2	412324-02	2	414513 8 Req'd	41457 7 Req'd	130 X 72 80 Req'd	412124	307353 8 Req'd	307354 8 Req'd
16VC600	Minus side conn. Side conn.	402703	402704	-	-	92 X 6	2	87 X 12	2	412178-03	2	412324-02	2	414580 8 Req'd	414579 8 Req'd	130 X 72 80 Req'd	412125	201301 8 Req'd	301352 8 Req'd
20VC600	Minus side conn. Side conn.	402732	402733	-	-	92 X 6	2	87 X 12	2	412178-03	2	412324-02	2	307369 10 Req'd	307358 10 Req'd	130 X 71 100 Req'd	412126	201301 10 Req'd	301352 10 Req'd
24VC650	Minus side conn. Side conn.	402803	402804	-	-	92 X 7	2	87 X 14	2	412178-05	2	412324-03	2	414582 12 Req'd	414581 12 Req'd	130 X 72 120 Req'd	412127	201285 12 Req'd	301352 12 Req'd
28VC650	Minus side conn. Side conn.	402694	402693	-	-	92 X 7	2	87 X 14	2	412178-05	2	412324-03	2	414584 14 Req'd	414583 14 Req'd	130 X 73 140 Req'd	412128	201285 14 Req'd	301352 14 Req'd
33CV650	Minus side conn. Side conn.	402821	402822	-	-	92 X 8	2	87 X 16	2	412178-06	2	412324-04	2	414586 16 Req'd	414585 16 Req'd	130 X 73 160 Req'd	412129	201283 16 Req'd	301333 16 Req'd
37VC650	Minus side conn. Side conn.	402671	402670	-	-	92 X 8	2	87 X 16	2	412178-06	2	412324-04	2	414586 18 Req'd	414585 18 Req'd	130 X 73 180 Req'd	412130	201283 18 Req'd	301333 18 Req'd
42VC650	Minus side conn. Side conn.	402829	402830	-	-	92 X 8	2	87 X 16	2	412178-06	2	412324-04	2	414590 8 Req'd	414589 8 Req'd	130 X 73 200 Req'd	412131	201283 20 Req'd	301333 20 Req'd

7.2 Dual narrow element assemblies

		Item						Item			
		Complete dual element	Single elements*	8	9			Complete dual element	Single elements*	8	9
11.5VC500	Element with four side connections	142112C	142639HA	105808A	105898	28VC650	Element with four side connections	142118C	142643HA	105811A	105901
14VC500		143114C	143829HA	105809A	105899	33VC650		142119C	142644HA	105812A	105902
16VC600		142115C	142640HA	105810A	105900	37VC650		142120C	142645HA	105812A	105903
20VC600		142116C	142641HA	105810A	105900	42VC650		142121C	142647HA	105812A	105904
24VC650		142117C	142642HA	105811A	105901						

*The second column under "ITEM" lists the part number of the two single elements that make up the dual mounted element assembly. To find part numbers of components, locate the element number in the parts list for single element application. Find the part numbers in the corresponding item column.

Airflex model VC Grinding mill clutches

7.3 Single wide element assemblies

	Element description	No. of air inlets	Part no. of complete element	Item																
				1	2	3	4	5	6	7	10	11	12	13						
			Part no. 1 req'd	Tube 1 req'd	Snap ring 4 req'd	Part no.	Qty	Part no.	Qty	Part no.	Qty	Part no.	Qty	Rivet	Lining	Screw	Nut	Part no. 2 Req'd	Part no.	
14VC 1000	Minus side conn.	1,2 or 4	142838HA	409141-406978	-	92 X 6 2	87 X 12 2	412178-03	2	412324-02	2	414592 8 Req'd	130 X 72 98 Req'd	414591 16 Req'd	-	-	-	412124	303567 8 Req'd	303150 8 Req'd
	Side connection	2	142838HP			-	-	-	-	-	-	-	-	-	-	-	-	-	-	-
16VC 1000	Minus side conn.	1,2 or 4	142821HA	405950-405954	-	92 X 6 2	87 X 12 2	412178-03	2	412324-02	2	414594 8 Req'd	130 X 72 80 Req'd	414593 8 Req'd	-	-	-	412156	301831 8 Req'd	301832 8 Req'd
	Side connection	2	142821HP			-	-	-	-	-	-	-	-	-	-	-	-	-	-	-
	Side connection	4	142821HC			4	4	4	4	02	4									
20VC 1000	Minus side conn.	1,2 or 4	142832HA	503302-406544	-	92 X 6 2	87 X 12 2	412178-03	2	412324-02	2	414596 8 Req'd	130 X 72 80 Req'd	414595 8 Req'd	-	-	-	412157	301831 8 Req'd	301832 8 Req'd
	Side connection	2	142832HP			-	-	-	-	-	-	-	-	-	-	-	-	-	-	-
	Side connection	4	142832HC			4	4	4	4	02	4									
24VC 1000	Minus side conn.	1,2 or 4	142675HA	404666-404675	-	92 X 7 2	87 X 14 2	412178-05	2	412324-03	2	414598 10 Req'd	130 X 72 100 Req'd	414597 10 Req'd	-	-	-	412158	301831 10 Req'd	301832 10 Req'd
	Side connection	2	142675HP			-	-	-	-	-	-	-	-	-	-	-	-	-	-	-
	Side connection	4	142675HC			4	4	4	4	03	4									
28VC 1000	Minus side conn.	1,2 or 4	142674HA	405503-403745	-	92 X 7 2	87 X 14 2	412178-05	2	412324-03	2	414600 10 Req'd	130 X 72 100 Req'd	414599 10 Req'd	-	-	-	412159	301831 10 Req'd	301832 10 Req'd
	Side connection	2	142674HP			-	-	-	-	-	-	-	-	-	-	-	-	-	-	-
	Side connection	4	142674HC			4	4	4	4	03	4									
32VC1000	Minus side conn.	1,2 or 4	142673HA	402330-402327	-	92 X 7 2	87 X 14 2	412178-05	2	412324-03	2	414602 12 Req'd	110 X 23 120 Req'd	414601 12 Req'd	330 X 206 120 Req'd	330 X 206 120 Req'd	110 X 23 120 Req'd	412160	301839 12 Req'd	301718 12 Req'd
	Side connection	2	142673HP			-	-	-	-	-	-	-	-	-	-	-	-	-	-	-
	Side connection	4	142673HC			4	4	4	4	03	4									
38VC 1200	Minus side conn.	1,2 or 4	142739HA	404503-404504	190 X 3	92 X 8 2	87 X 16 2	412178-06	2	412324-04	2	511640 12 Req'd	110 X 23 120 Req'd	511639 12 Req'd	330 X 208 120 Req'd	330 X 208 120 Req'd	110 X 23 120 Req'd	412161	302115 12 Req'd	301908 12 Req'd
	Side connection	2	142739HP			-	-	-	-	-	-	-	-	-	-	-	-	-	-	-
	Side connection	4	142739HC			4	4	4	4	04	4									
42VC 1200	Minus side conn.	1,2 or 4	142677HA	403800-403799	190 X 3	92 X 8 2	87 X 16 2	412178-06	2	412324-04	2	511642 14 Req'd	110 X 23 140 Req'd	511641 14 Req'd	330 X 208 140 Req'd	330 X 208 140 Req'd	110 X 23 140 Req'd	412162	302115 14 Req'd	301908 14 Req'd
	Side connection	2	142677HP			-	-	-	-	-	-	-	-	-	-	-	-	-	-	-
	Side connection	4	142677HC			4	4	4	4	04	4									
46VC 1200	Minus side conn.	1,2 or 4	142671HA	404602-403901	190 X 3	92 X 8 2	87 X 16 2	412178-07	2	412324-04	2	414439 16 Req'd	110 X 23 192 Req'd	414438 32 Req'd	330 X 206 192 Req'd	330 X 206 192 Req'd	110 X 23 192 Req'd	412163	302115 16 Req'd	301908 16 Req'd
	Side connection	2	142671HP			-	-	-	-	-	-	-	-	-	-	-	-	-	-	-
	Side connection	4	142671HC			4	4	4	4	04	4									
52VC 1200	Minus side conn.	1,2 or 4	142841HA	503985-503986	190 X 83	92 X 8 2	87 X 20 2	412178-08	2	412324-05	2	414439 18 Req'd	110 X 23 216 Req'd	414438 36 Req'd	330 X 206 216 Req'd	330 X 206 216 Req'd	110 X 23 216 Req'd	412164	303929 18 Req'd	301908 18 Req'd
	Side connection	2	142841HP			-	-	-	-	-	-	-	-	-	-	-	-	-	-	-
	Side connection	4	142841HC			4	4	4	4	05	4									
51VC 1600	Minus side conn.	1,2 or 4	142835HA	506674-505580	190 X 83	92 X 2	87 X 20 2	412178-09	2	412324-05	2	511644 18 Req'd	110 X 23 216 Req'd	511643 38 Req'd	330 X 206 216 Req'd	330 X 206 216 Req'd	110 X 23 216 Req'd	412165	308639 18 Req'd	304215 36 Req'd
	Side connection	2	142835HP			-	-	-	-	-	-	-	-	-	-	-	-	-	-	-
	Side connection	4	142835HC			4	4	4	4	05	4									
60VC 1600	Minus side conn.	1,2 or 4	142915MB	510629-511348	190 X 15	153 X 2	87 X 20 2	412178-18	2	412324-06	2	511646 20 Req'd	110 X 23 240 Req'd	511645 40 Req'd	330 X 208 240 Req'd	330 X 208 240 Req'd	110 X 23 240 Req'd	412166	304214 20 Req'd	304215 40 Req'd
	Side connection	2	142915MA			-	-	-	-	-	-	-	-	-	-	-	-	-	-	-
	Side connection	4	142915HC			4	4	4	4	06	4									
66VC 1600	Minus side conn.	1,2 or 4	142097HA	509548-511350	190 X 15	92 X 4	87 X 20 4	412178-04	4	412324-06	4	511648 22 Req'd	110 X 23 264 Req'd	511645 44 Req'd	330 X 208 264 Req'd	330 X 208 264 Req'd	110 X 23 264 Req'd	509527	304214 22 Req'd	304215 44 Req'd
	Side connection	4	142097HC			-	-	-	-	-	-	-	-	-	-	-	-	-	-	-
76VC 1600	Side connection	4	-	515144-515142	190 X 15	92 X 4	87 X 20 4	412178-04	4	412324-06	4	515156 25 Req'd	110 X 23 300 Req'd	515145 50 Req'd	330 X 208 300 Req'd	330 X 208 300 Req'd	110 X 23 300 Req'd	515140	304214 25 Req'd	304215 50 Req'd
	Side connection	4	-	515377-515375	190 X 15	92 X 4	87 X 20 4	412178-04	4	412324-06	4	515381 25 Req'd	110 x 23 400 Req'd	515380 50 Req'd	330 x 23 400 Req'd	330 x 23 400 Req'd	110 x 23 400 Req'd	515384	308576 25 Req'd	308577 25 Req'd

7.4 Dual wide element assemblies

		Item				Item					
		Complete dual element	Single elements*	8	9	Complete dual element	Single elements*	8	9		
16VC1000	Element with four side connections	142122C	142821HA	105815A	105905	42VC1200	Element with four side connections	142128C	142677HA	105817A	105908
20VC1000		142123C	142832HA	105815A	105906	46VC1200		142129C	142671HA	105891A	105909
24VC1000		142124C	142675HA	105816A	105901	52VC1200		142131C	142841HA	105893A	105910
28VC1000		142125C	142674HA	105816A	105901	51VC1600		142130C	142835HA	105892A	105910
32VC1000		142126C	142673HA	105816A	105906	60VC1600		142132AL	142915MB	105894A	105911
38VC1200		142127C	142639HA	105817A	105907	66VC1600		142198P	142097HA	105897A	-
-		-	-	-	-	76VC1600		146509P	-	-	-
-		-	-	-	-	76VC2000		146531P	-	108131A	-

*The second column under "ITEM" lists the part number of the two single elements that make up the dual mounted element assembly. To find part numbers of com- ponents, locate the element number in the parts list for single element application. Find the part numbers in the corresponding item column.

7.5 Drums

Narrow series			Wide series			
Size	Single	Dual	Size	Single	Dual (Male)	Dual(Female)
11.5VC500	408290	408307*	14VC1000	411111*	-	-
14VC500	408283	408309*	16VC1000	409506*	412589	412590
16VC600	408292	408311*	20VC1000	410087	410087	410088
20VC600	408294	410862	24VC1000	409794	409794	409795
24VC650	408296	409804	28VC1000	409537	409537	409538
28VC650	409479	409706	32VC1000	410824	410824	410825
33VC650	408300	410022	38VC1200	409474	409474	409475
37VC650	408302	410866	42VC1200	409947	409947	409948
42VC650	408304	409964	46VC1200	409980	409980	409981
*Tapped holes			52VC1200	409715	409715	409716
			51VC1600	409711	409711	409712
			60VC1600	411501	411501	411502
			66VC1600	413727	413727	413726
			76VC1600	515149	515149	515150
			76VC2000	515382	515382	515383

7.6 Axial locking device

Dual narrow series		Single wide series				Dual wide series			
20VC600	145839DH	20VC1000	145839DP	42VC1200	145839DA	20VC1000	145839DP	46VC1200	145839DC
24VC650	145839DL	24VC1000	145839DS	46VC1200	145839DC	24VC1000	145839DS	52VC1200	145839DT
28VC650	145839DF	28VC1000	145839DG	52VC1200	145839DT	28VC1000	145839DG	51VC1600	145839DD
33VC650	145839DL	32VC1000	145839DE	51VC1600	145839DD	32VC1000	145839DE	60VC1600	145839DU
37VC650	145839DM	38VC1200	145839DB	60VC1600	145839DU	38VC1200	145839DB	66VC1600	145839DW
42VC650	145839DN					42VC1200	145839DA	76VC1600	145839EJ
-	-					-	-	76VC2000	145839EL

Airflex model VC Grinding mill clutches

7.7 Friction block and rivet kits

Element size	Narrow series			Element size	Wide series		
	Kit no.	Qty friction blocks	Qty.**rivets		Kit no.	Qty friction blocks	Qty.**rivets
11.5VC500	146236AA	8	54	14VC1000	146237AA	16	102
14VC500	146236AB	8	90	16VC1000	146237AB	8	90
16VC600	146236AC	8	90	20VC1000	146237AC	8	90
20VC600	146236AD	10	110	24VC1000	146237AD	10	110
24VC650	146236AE	12	130	28VC1000	146237AE	10	110
28VC650	146236AF	14	150	32VC1000	146237AF	12	130*
33VC650	146236AG	16	170	38VC1200	146237AG	12	130*
35VC650	146236AH	18	190	42VC1200	146237AH	14	150*
37VC650	146236AJ	18	190	46VC1200	146237AJ	32	198*
42VC650	146236AK	20	210	52VC1200	146237AK	36	222*
				51VC1600	146237AL	36	222*
				60VC1600	146237AM	40	246*
				66VC1600	146237AN	44	270*
				76VC1600	146237AR	50	306*
				76VC2000	146237AW	50	416*

* Fasteners for these sizes are screws and nuts - all other sizes use rivets.
 ** Extra fasteners supplied with each kit.

7.8 Friction shoe assembly, torque bar and release spring kits

Element size	Narrow series				Element size	Wide series			
	Kit no.	Qty friction blocks	Qty torque bars	Qty springs		Kit no.	Qty friction blocks	Qty torque bars	Qty springs
11.5VC500	146236A	8	8	8	14VC1000	146237A	8	8	8
14VC500	146236B	8	8	8	16VC1000	146237B	8	8	8
16VC600	146236C	8	8	8	20VC1000	146237C	8	8	8
20VC600	146236D	10	10	10	24VC1000	146237D	10	10	10
24VC650	146236E	12	12	12	28VC1000	146237E	10	10	10
28VC650	146236F	14	14	14	32VC1000	146237F	12	12	12
33VC650	146236G	16	16	16	38VC1200	146237G	12	12	12
35VC650	146236H	18	18	18	42VC1200	146237H	14	14	14
37VC650	146236J	18	18	18	46VC1200	146237J	16	16	16
42VC650	146236K	20	20	20	52VC1200	146237K	18	18	18
					51VC1600	146237L	18	18	36
					60VC1600	146237M	20	20	40
					66VC1600	146237N	22	22	44
					76VC1600	146237V	25	25	50
					76VC2000	146237W	25	25	25

8.0 Revision

Original publication date : March, 2010

Revision date	Change	Page(s)
November 2006	Added 76vc1600 revision	Various
	Update cover to current standards	Cover
	Adjusted copyright date	All
	Added call-out (7) "friction shoe assembly" to figure 1	1
	Added dw76vc2000 to table 1	6
	Added sw76vc1600 to table 2	7
	Added sw76vc2000 to table 2	7
	Added dw76vc2000 to table 2	7
	Added 76vc1600 to table 3	11
	Added 76vc2000 to table 3	11
	Removed the word (continued) from table 4	16
	Added 76vc2000 to table 5	18
	Changed maximum rpm of 76vc1600 from 480 to 275 in table 5	18
	Changed element size from 51 thru 76vc1600 to thru 76vc2000 in table 6	20
	March 2010	Changed element size 76vc1600 to 76vc2000 in table 7
Added 76vc1600 and 76vc2000 to table 8		23
Corrected 2vc1000 to 20vc1000 in figure 14		23
Corrected 20vc800 to 20vc600 in table 8		23
Corrected internet address		25
Changed part # 301906 to #301908 in section 7.3		28
Added 76vc2000 to section 7.3		28
Added 76vc2000 to section 7.4		29
Added 76vc2000 to section 7.5		29
Added 76vc2000 to section 7.6		30
Added 76vc2000 to section 7.7		30
Added 76vc2000 to section 7.8		31
Added section 8.0 Revisions		32
Updated warranty page		Last
February 2012	Copyright & revision year changed	All
	Air piping diagram changed in figure 9	13
	Table description changed	13
December 2017	Corrected tolerance value in section 2.3.1 and section 2.4	10
	Corrected item #1 part # 510829 to #510629 in section 7.3	25
	Corrected item #1 part # 506874 to #506674 in section 7.3	25
	Corrected item #12 part # 304214 to #308639 in section 7.3	25
	Corrected item #11 qty from 1 to 2 in section 7.3	25
	Corrected 66VC1600 Dual element part # 142198C to #142198P in section 2.4	26
	Added part number & Mar Com part number on cover page	26
	Updated manual to current format	

Products we offer:

- Cartridge valves
- DCV directional control valves
- Electric converters
- Electric machines
- Electric motors
- Gear motors
- Gear pumps
- Hydraulic integrated circuits (HICs)
- Hydrostatic motors
- Hydrostatic pumps
- Orbital motors
- PLUS+1® controllers
- PLUS+1® displays
- PLUS+1® joysticks and pedals
- PLUS+1® operator interfaces
- PLUS+1® sensors
- PLUS+1® software
- PLUS+1® software services, support and training
- Position controls and sensors
- PVG proportional valves
- Steering components and systems
- Telematics

Hydro-Gear

www.hydro-gear.com

Daikin-Sauer-Danfoss

www.daikin-sauer-danfoss.com

Danfoss Power Solutions is a global manufacturer and supplier of high-quality hydraulic and electric components. We specialize in providing state-of-the-art technology and solutions that excel in the harsh operating conditions of the mobile off-highway market as well as the marine sector. Building on our extensive applications expertise, we work closely with you to ensure exceptional performance for a broad range of applications. We help you and other customers around the world speed up system development, reduce costs and bring vehicles and vessels to market faster.

Danfoss Power Solutions – your strongest partner in mobile hydraulics and mobile electrification.

Go to www.danfoss.com for further product information.

We offer you expert worldwide support for ensuring the best possible solutions for outstanding performance. And with an extensive network of Global Service Partners, we also provide you with comprehensive global service for all of our components.

Local address:

**Danfoss
Power Solutions (US) Company**
2800 East 13th Street
Ames, IA 50010, USA
Phone: +1 515 239 6000

**Danfoss
Power Solutions GmbH & Co. OHG**
Krokamp 35
D-24539 Neumünster, Germany
Phone: +49 4321 871 0

**Danfoss
Power Solutions ApS**
Nordborgvej 81
DK-6430 Nordborg, Denmark
Phone: +45 7488 2222

**Danfoss
Power Solutions Trading
(Shanghai) Co., Ltd.**
Building #22, No. 1000 Jin Hai Rd
Jin Qiao, Pudong New District
Shanghai, China 201206
Phone: +86 21 2080 6201