



**ENGINEERING
TOMORROW**

Technical Information
Airflex Spring Applied Brakes

CS and CSA Brake Elements 232

Technical and Dimensional Data 233

Applications 235

Component Parts 237

CTE Brake Elements..... 239

Technical and Dimensional Data 240

Component Parts 240

CS, CSA and CTE Brake Drums 244

Selection Procedure..... 245

Airflex Brake Element Descriptions

General

This document covers the CS and CTE spring-applied brakes. In addition to these models, two other spring applied brake models are available which are more appropriately covered in their respective documents. They are the DBair release brake in and the WCSB water-cooled brake.

Description

The brakes are pressure released and spring set. They automatically engage upon loss of release pressure. This feature coupled with a low releasing volume requirement results in a very responsive brake providing maximum operator and equipment protection. Because of their fast response, a flow control valve is often used to restrict exhaust of the pressurizing media in order to regulate brake stopping time.

These brakes were designed for air release. Any other media could be used provided they are compatible with the piston rubber compounds. Fluid viscosity will affect brake response time.

Where Used:

- Conveyors
- Drag Lines
- Hoists
- Power Shovels
- Stamping Presses

Size	Forward Dynamic Torque	
	English lb · in	SI N · m
4CS150	3000	339
6CSA200	6000	678
9CSA200	13000	1470
12CSA200	18000	2030
15CS300	22000	2490
18CS300	27000	3050
12CTE237	28800	3250
18CTE300	81900	9250
24CTE500	111200	12600

CS Brakes



Model CS brakes are of the two shoe drum design and are designed to be self-energizing when mounted with the proper drum rotation. They are unidirectional brakes developing substantially less torque in the reverse drum rotation than in the forward drum rotation as indicated by the arrow on the brake shoe. CS brakes are recommended for low to medium braking requirements.

Brake construction consists of two shoes hinged together by a pin. The combination shoe has the releasing cylinder attached to it. Pressurizing the cylinder forces the shoes apart, releasing the brake. When the cylinder is not pressurized a spring clamps the two shoes around the brake drum. The spring force and drum rotation determines the torque capacity of the brake. The brake is supported and reacted by a reaction pin which passes thru a hole in the combination brake shoe.

There are six sizes of CS brakes, three of which are designated CSA to indicate minor construction differences. The sizes are identified by the outside drum diameter in inches on which they work and the width in inches of their friction lining. For instance, size 9CSA200 is designed to operate on a 9 inch diameter drum and has a friction lining width of 2 inches. The smallest CS brake operates on a 4 inch (102 mm) diameter drum and the largest on a 18 inch (457 mm) diameter drum.

Airflex CS and CSA Brake Elements

English		lb-in				psi
4CS150	142681FH	2000	500	3000	500	75
6CSA200	142742FH	4000	1500	6000	1500	60
9CSA200	142633FH	9000	2200	13000	2200	60
12CSA200	142611FH	12000	3000	18000	3000	60
15CS300	142638FH	15000	3500	22000	3500	60
18CS300	142614FH	18000	4000	27000	4000	60

Size	Part Number	Static Torque		Dynamic Torque		Minimum ^⑥ Releasing Pressure
		Forward	Reverse	Forward	Reverse	
4CS150	142681FH	226	56,5	339	56,5	5,2
6CSA200	142742FH	452	170	678	170	4,1
9CSA200	142633FH	1020	249	1470	249	4,1
12CSA200	142611FH	1360	339	2030	339	4,1
15CS300	142638FH	1700	396	2490	396	4,1
18CS300	142614FH	2030	452	3050	452	4,1
SI		N·m				bar

English	in ²	in ³	lb	rpm	Dimensions in in		
4CS150	9	10	11	1800	0.25	0.12	3.92
6CSA200	20	25	39	1800	0.31	0.15	5.90
9CSA200	33	25	45	1200	0.31	0.15	8.90
12CSA200	45	25	53	900	0.31	0.15	11.90
15CS300	89	40	95	700	0.38	0.19	14.88
18CS300	108	45	115	600	0.38	0.19	17.88

Size	Friction Area	Releasing Volume ^⑥	Weight Mass	Maximum Speed ^⑦	Lining Thickness		Minimum Drum Diameter
					New	Worn	
4CS150	58	0,16	5,0	1800	6	3	100
6CSA200	129	0,41	18	1800	8	4	150
9CSA200	213	0,41	20	1200	8	4	226
12CSA200	290	0,41	24	900	8	4	302
15CS300	574	0,66	43	700	10	5	378
18CS300	697	0,74	52	600	10	5	454
SI	cm ²	dm ³	kg	rpm	Dimensions in mm		

Notes:

- ① Tolerance +0.001/-0.000 in (+0,03/-0,00 mm)
- ② Tolerance 0.005 in (0,13 mm)
- ③ American National Pipe Thread
- ④ Radius dimensions for clearance purposes.
- ⑤ Maximum allowable cylinder pressure is 110 psi (7,6 bar).
- ⑥ Absolute volume of releasing cylinder.
- ⑦ Speed is dependent upon operating conditions and varies for each application.

Airflex CS and CSA Brake Elements

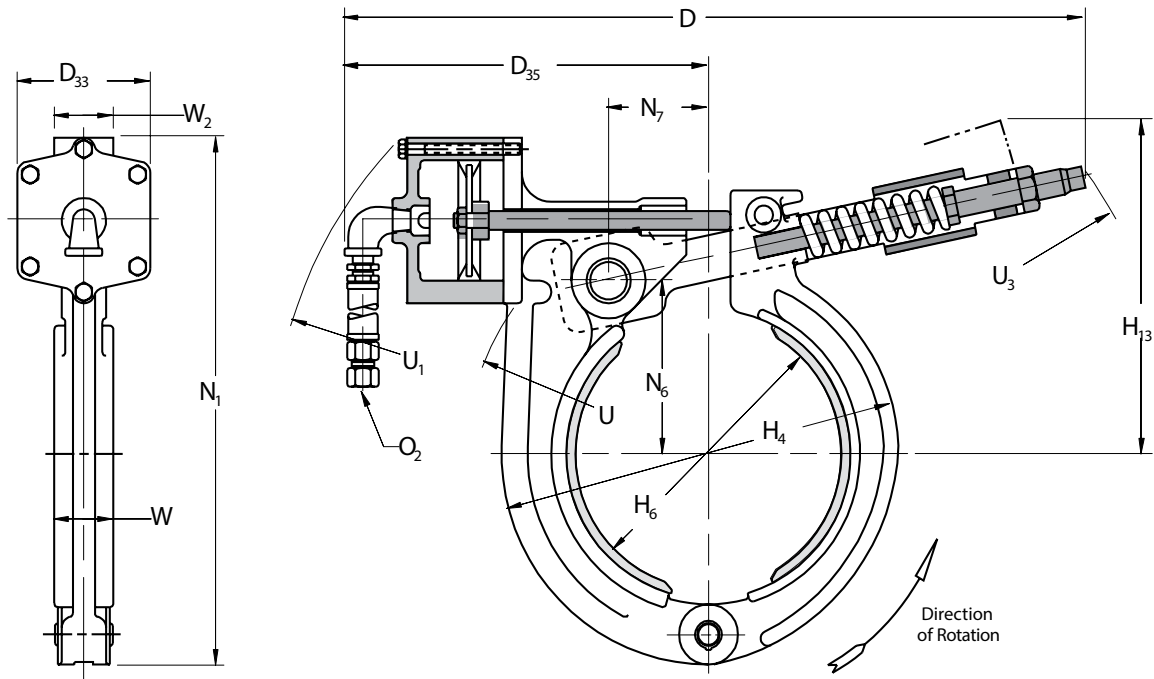

6 Thru 12 CSA 200

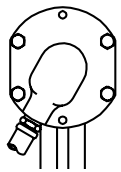

4CS150

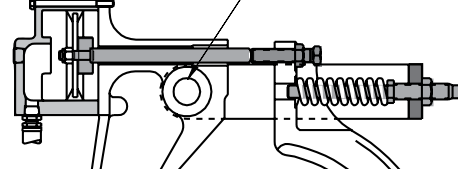
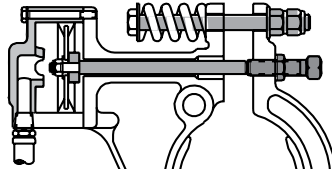

15 & 18CS300

English	Dimensions in inches															
4CS150	11.06	3.56	7.75	6.62	4.00	0.752	5.94	9.19	2.500	1.500	1/4-18	5.12	9.38	N/A	1.50	1.50
6CSA200	23.25	4.50	11.00	10.50	6.00	1.002	8.62	15.25	4.750	2.250	1/2-14	7.00	13.50	14.50	2.00	2.00
9CSA200	25.25	4.50	12.50	14.00	9.00	1.252	9.88	17.50	5.750	3.375	1/2-14	8.38	14.75	15.75	2.00	2.00
12CSA200	28.25	4.50	14.75	16.76	12.00	1.502	12.25	20.38	7.250	4.188	1/2-14	11.00	17.50	17.50	2.00	2.00
15CS300	25.58	6.00	13.88	20.88	15.00	1.502	13.25	27.00	11.250	4.188	1/2-14	13.12	21.00	16.50	3.00	3.56
18CS300	25.50	6.00	13.81	23.88	18.00	1.502	16.25	31.50	14.250	4.188	1/2-14	15.50	23.52	18.75	3.00	3.56
Size	D	D ₃₃	D ₃₅	H ₄	H ₆	H ₁₂	H ₁₃	N ₁	N ₆	N ₇	O ₂	U	U ₁	U ₃	W	W ₂
4CS150	281	90	197	168	102	19.1	151	233	63.5	38.1	1/4-18	130	238	N/A	38	38
6CSA200	591	114	279	267	152	25.5	219	387	120.7	57.2	1/2-14	178	343	368	51	51
9CSA200	641	114	318	356	229	31.8	251	445	146.1	85.7	1/2-14	213	375	400	51	51
12CSA200	718	114	375	426	305	38.2	311	518	184.2	106.4	1/2-14	279	445	445	51	51
15CS300	650	152	353	530	381	38.2	337	686	285.8	106.4	1/2-14	333	533	419	76	90
18CS300	648	152	351	607	457	38.2	413	800	362.0	106.4	1/2-14	394	597	476	76	90
SI	Dimensions in millimeters															

Airflex CS and CSA Brake Applications

English lb·in					
Size	Element Part Number	Static Torque	D y n a m i c Torque		
			Forward	Reverse	Reverse
4CS150	142681FH	2000	500	3000	500
6CSA200	142742FH	4000	1500	6000	1500
9CSA200	142633FH	9000	2200	13000	2200
12CSA200	142611FH	12000	3000	18000	3000
4CS150	142681FH	226	56,5	339	56,5
6CSA200	142742FH	452	170	678	170
9CSA200	142633FH	1020	249	1470	249
12CSA200	142611FH	1360	339	2030	339

SI N·m

English	lb	lb·ft ²	lb	lb·ft ²
4CS150	3	0.1	1.6	0.1
6CSA200	9	0.3	4	0.1
9CSA200 ⑦	16	1.3	4	0.1
9CSA200 ⑧	19	1.5	8	0.2
12CSA200	28	3.5	16	0.5
Size	Integral Drum		Bushing	
	Weight Mass	Wk ² J	Weight Mass	Wk ² J
4CS150	1,4	0,004	0,7	0,004
6CSA200	4,1	0,01	1,8	0,004
9CSA200 ⑦	7,2	0,05	1,8	0,004
9CSA200 ⑧	8,6	0,06	3,6	0,01
12CSA200	13	0,15	7,2	0,02
SI	kg	kg·m ²	kg	kg·m ²

4CS150

Bushing Bore in	Bushing Part No.
0.875	304037-7
0.938	304037-8
1.000	304037-9
1.063	304037-10
1.125	304037-11
1.188	304037-12
1.250	304037-13
1.313	304037-14
1.375	304037-15
1.438	304037-16

6 and 9CSA200

Bushing Bore in	Bushing Part No.
1.250	304039-9
1.313	304039-10
1.375	304039-11
1.438	304039-12
1.500	304039-13
1.563	304039-14
1.625	304039-15
1.688	304039-16
1.750	304039-17
1.813	304039-18
1.875	304039-19
1.938	304039-20
2.000	304039-21

9CSA200

Bushing Bore in	Bushing Part No.
2.063	304041-16
2.125	304041-17
2.188	304041-18
2.250	304041-19
2.313	304041-20
2.375	304041-21
2.438	304041-22
2.500	304041-23

12CSA200

Bushing Bore in	Bushing Part No.
2.563	304043-12
2.625	304043-13
2.688	304043-14
2.750	304043-15
2.813	304043-16
2.875	304043-17
2.938	304043-18
3.000	304043-19
3.063	304043-20
3.125	304043-21
3.188	304043-22
3.250	304043-23

Size

Part Numbers

	Integral Drum	Reaction Pin
4CS150	407854	410794-04
6CSA200	405325	410794-07
9CSA200	408423 ⑦	410794-01
9CSA200	406777 ⑧	410794-01
12CSA200	304100	410794-08

Notes:

- ① Refers to basic part number only. Bushing bore must be specified. ② Includes brake element, drum, bushing and reaction pin.
- ③ Bushing only available for inch series shafting in 0.063 inch increments.
- ④ Tolerance +0.001/-0.000 in (+0,03/-0,00 mm)
- ⑤ Tolerance 0.005 in (0,13 mm).
- ⑥ American National Pipe Thread
- ⑦ For bushing bores 1.500 thru 2.000 inches.
- ⑧ For bushing bores 2.063 thru 2.500 inches.

Airflex CS and CSA Brake Applications

Shaft, key and reaction pin bracket by customer. Refer to Form CS 801 for brake element dimensional and technical data.

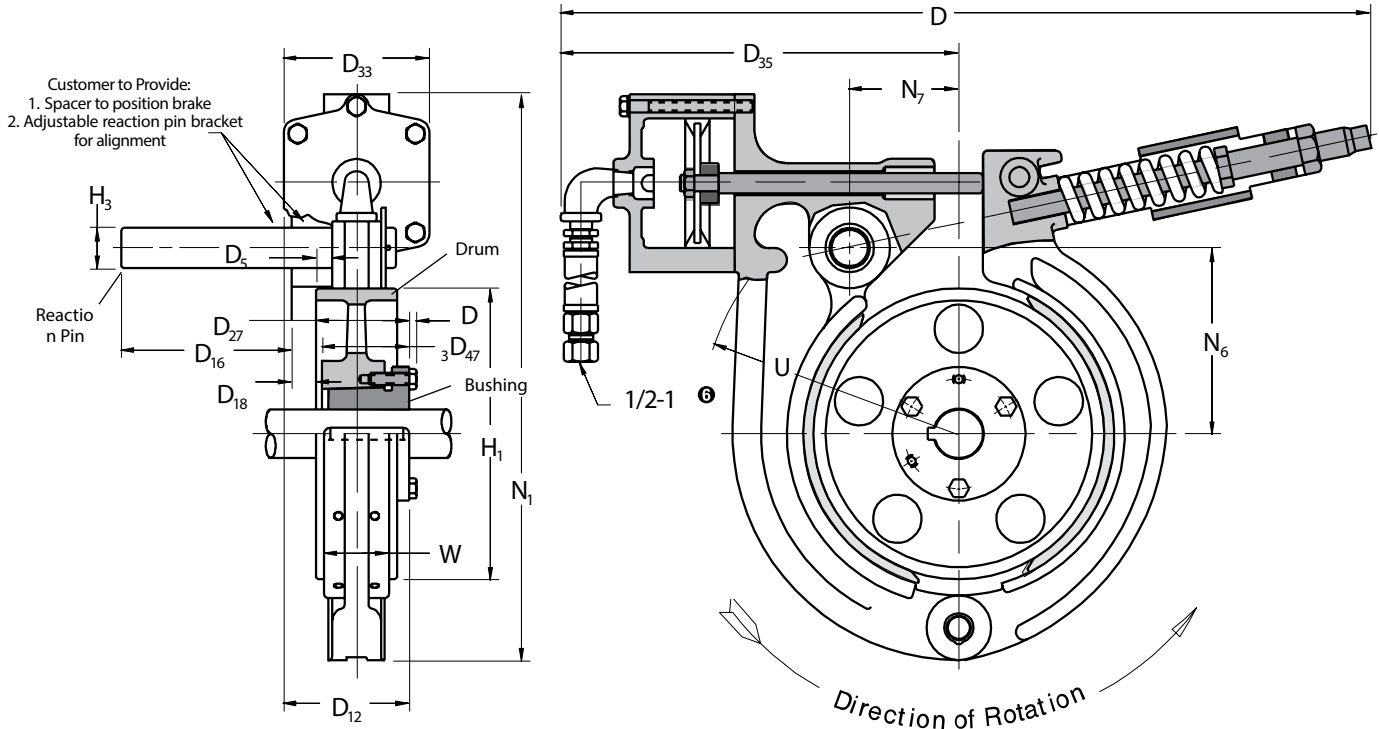

English	lb	Dimensions in inches														
4CS150	103522	20	0.875 thru 1.438	11.06	0.23	0.38	4.97	0.25	2.75	2.13	3.56	2.00	0.749	9.19	2.500	1.500
6CSA200	103523	50	1.250 thru 2.000	23.25	0.28	0.25	4.38	0.38	3.91	2.81	4.70	2.69	0.999	15.25	4.750	2.250
9CSA200	103524	75	1.500 thru 2.000	25.25	0.28	0.25	5.41	0.38	4.06	3.06	4.50	2.69	1.249	17.50	5.750	3.375
9CSA200	103525	75	2.063 thru 2.500	25.25	0.28	0.25	5.41	0.38	4.38	3.38	4.50	3.00	1.249	17.50	5.750	3.375
12CSA200	103526	105	2.563 thru 3.250	28.25	0.38	0.25	5.44	0.38	5.81	4.81	4.50	4.38	1.499	20.38	7.250	4.188

Size	¹ Part Number	² Weight Mass	³ Bushing Bore Range	D	D ₃	D ₅	D ₁₆	D ₁₈	D ₃₂	D ₂₇	D ₃₃	D ₄₇	H ₃ ⁴	N ₁	N ₆ ⁵	N ₇ ⁶
4CS150	103522	9,1	0.875 thru 1.438	281	6	10	126	6	70	54	90	51	19.0	233	63.5	38.1
6CSA200	103523	23	1.250 thru 2.000	591	7	6	111	10	99	71	119	68	25.4	387	120.7	57.2
9CSA200	103524	34	1.500 thru 2.000	641	7	6	137	10	103	78	114	68	31.7	445	146.1	85.7
9CSA200	103525	34	2.063 thru 2.500	641	7	6	137	10	111	86	114	76	31.7	445	146.1	85.7
12CSA200	103526	48	2.563 thru 3.250	718	10	6	138	10	148	122	114	111	38.1	518	184.2	106.4
SI		kg	inches	Dimensions in millimeters												

Airflex CS and CSA Component Parts

Item No.	Component Description
1	Rivet
2	Nameplate
3	Brake Shoe
4	Pin
5	Snap Ring
6	Friction Lining
7	Combo Brake Shoe
8	Hose Assembly
9	Cylinder
10	Warning Plate
11	Locknut
12	Piston
13	Hex Head Screw
14	Lockwasher
15	Spacer
16	Piston Rod

Item No.	Component Description
17	Bushing
18	Locknut
19	Adjusting Screw
20	Spring
21	Washer
22	Spring Rod
23	Locknut
24	Ext Tooth Washer
25	Washer
26	Spring Shield
27	Hex Head Screw
28	Clevis
29	Pipe Plug
30	Street Elbow
31	Bushing
32	Reaction Pin

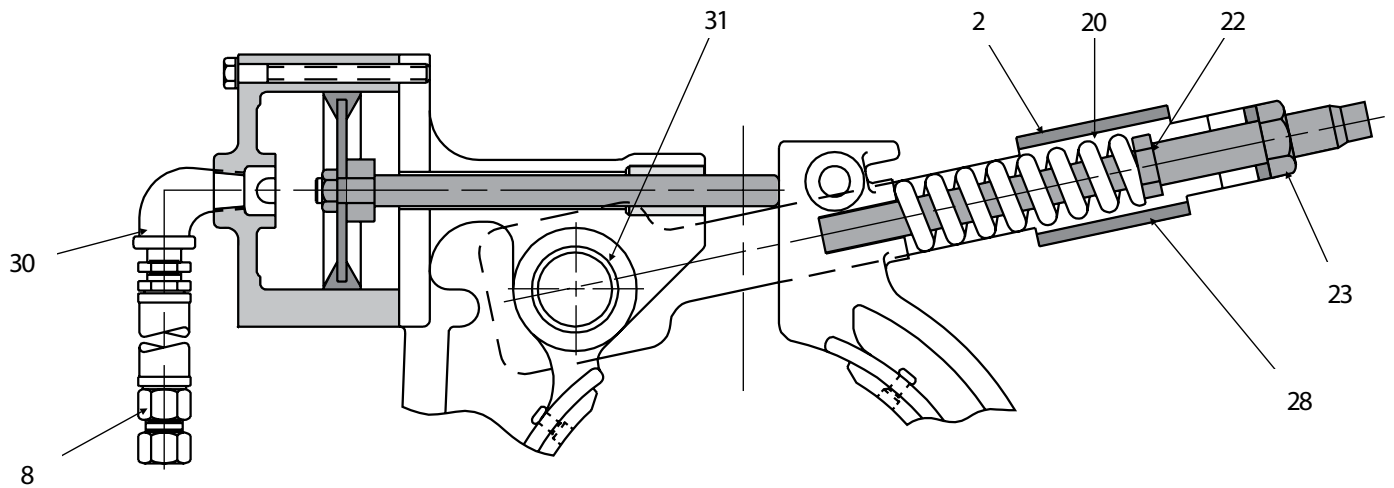

Airflex CS and CSA Component Parts

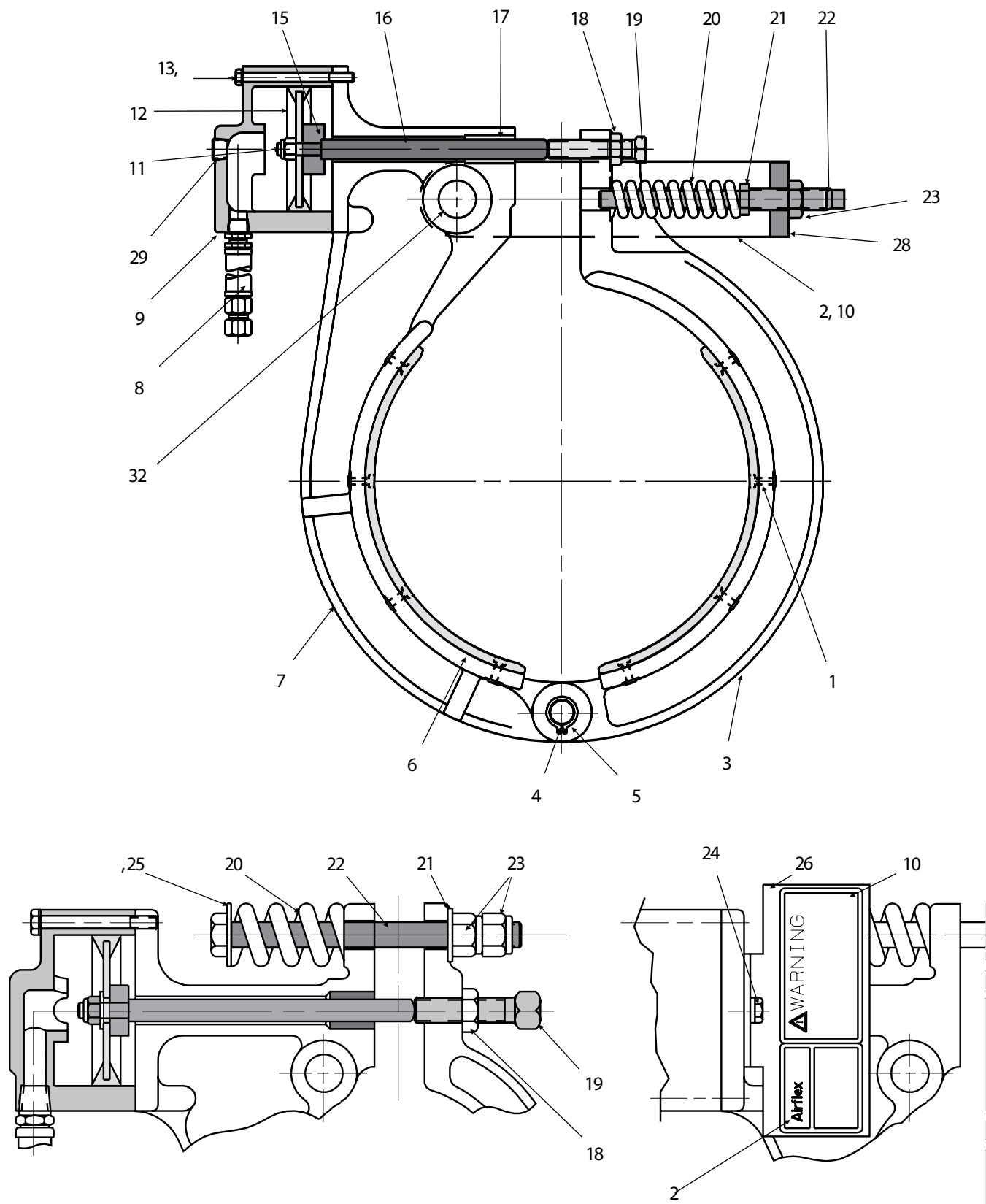

Airflex Brake Element Descriptions

CTE Brakes

CTE brakes are also of the two shoe drum type. Their design and construction enables them to develop larger braking torques than the CS brakes. Brake torque is slightly larger in the forward direction of drum rotation than in the reverse direction. The direction of forward drum rotation is indicated on the brake element. CTE brakes are recommended for medium to heavy duty braking requirements.

The brake shoes are weld steel fabrications and are hinged together by a pin. They are supported at their other ends by a trunnion assembly. The trunnion contains the brake springs and provides a means of supporting and reacting the brake through a reaction pin. The force exerted by the springs determines the torque capacity of the brake. Pressurizing the releasing cylinder counteracts the spring forces and opens the brake shoes.

There are three sizes of CTE brake. They are identified by the outside drum diameter in inches on which they operate and the width in inches of their friction lining. The brakes operate on drum diameters of 12 inch (305 mm), 18 inch (457 mm) and 24 inch (610 mm).



Airflex CTE Brake Elements

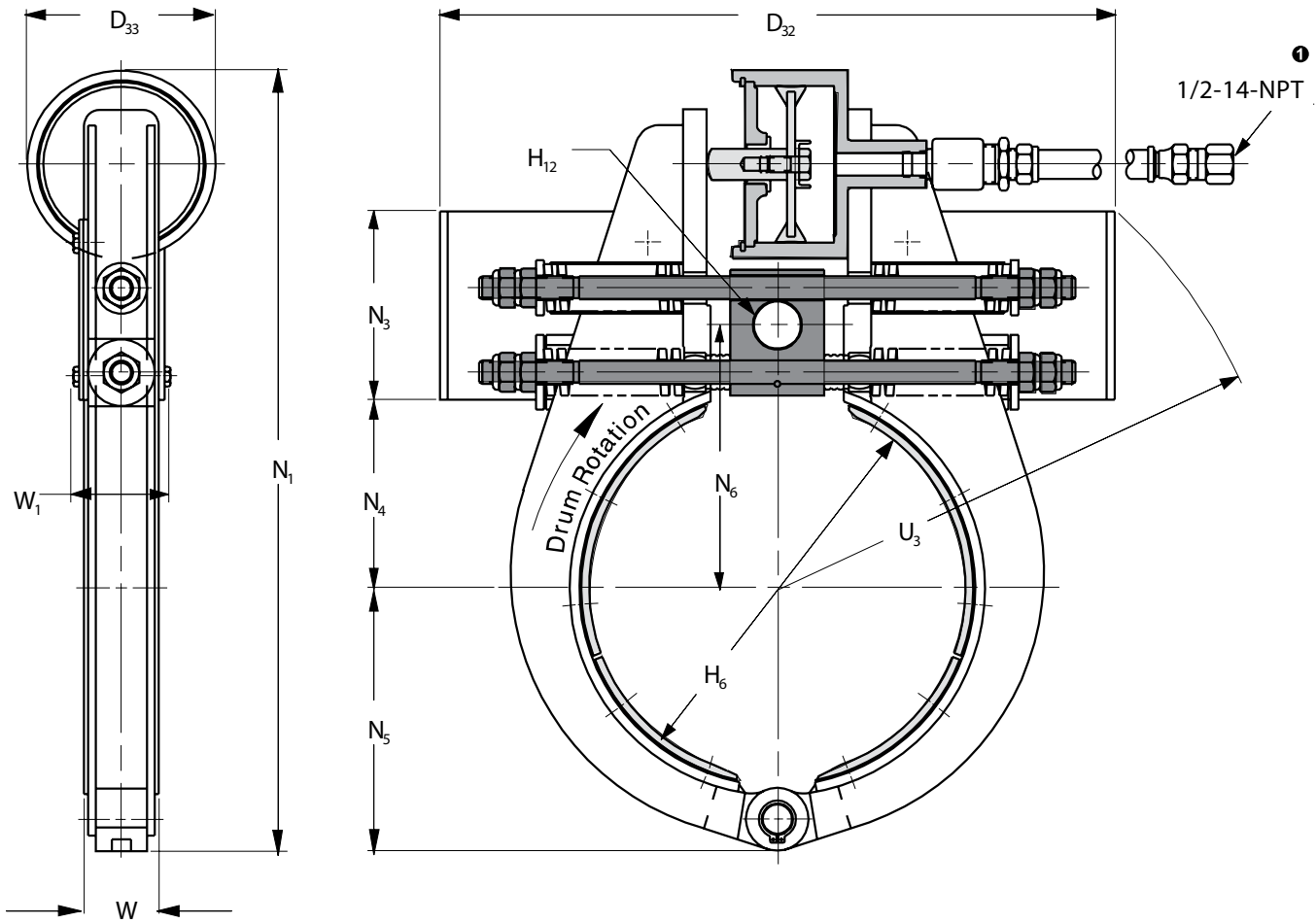

English	Dimensions in inches											
12CTE237	21.50	6.00	12.00	1.502	24.88	5.75	6.00	8.38	8.375	16.50	2.38	3.00
18CTE300	26.88	6.00	18.00	1.502	34.88	5.75	10.75	12.25	13.312	21.38	3.00	3.41
24CTE500	34.50	7.00	24.00	2.001	43.50	6.50	13.75	16.00	16.562	26.75	5.00	5.19
Size	D_{32}	D_{33}	H_6	H_{12} ⓐ	N_1	N_3	N_4	N_5	N_6	U_3	W	W_1
12CTE237	546	152	305	38,2	632	146	152	213	212,7	419	60	76
18CTE300	683	152	457	38,2	886	146	273	311	338,1	543	76	87
24CTE500	876	178	610	50,8	1105	165	349	406	420,7	679	127	132
SI	Dimensions in millimeters											

Airflex CTE Brake Elements

English		lb·in				psi
12CTE237	142611CB	21000	21000	28800	28800	75
18CTE300	142614CA	69000	57600	81900	79600	60
24CTE500	142740CA	98500	85500	111200	100800	60
Size	Part Number	Static Torque		Dynamic Torque		Minimum Releasing Pressure ^④
		Forward	Reverse	Forward	Reverse	
12CTE237	142611CB	2370	2370	3250	3250	5.2
18CTE300	142614CA	7800	6510	9250	8990	4.1
24CTE500	142740CA	11100	9660	12600	11400	4.1
SI		N·m				bar

English	in ²	in ³	lb	rpm	Dimension in in		
12CTE237	65	40	85	1800	0.31	0.15	11.94
18CTE300	152	30	180	1200	0.38	0.19	17.97
24CTE500	328	100	310	900	0.50	0.25	23.88
Size	Friction Area	④ Release Volume	Weight Mass	⑤ Maximum Speed	Lining Thickness		Minimum Drum Diameter
					New	Worn	
12CTE237	419	0.66	39	1800	8	4	303
18CTE300	980	0.49	82	1200	10	5	456
24CTE500	2116	1.64	140	900	13	6	607
SI	cm ²	dm ³	kg	rpm	Dimensions in mm		

Notes:

- ① American National Pipe Thread
- ② Tolerance +0.000/-0.001 in (+0,00/-0,03 mm).
- ③ Maximum allowable cylinder pressure is 110 psi (7.6 bar).

- ④ Absolute volume of releasing cylinder.
- ⑤ Speed is dependent upon operating conditions and varies for each application.

Airflex CTE Component Parts

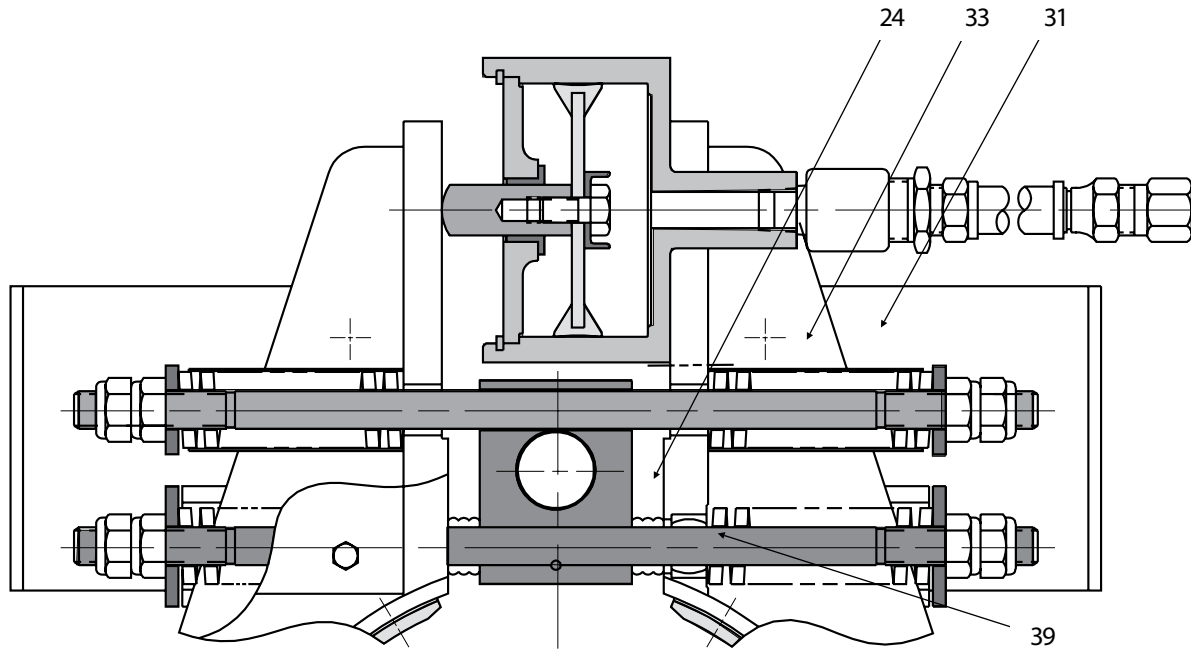

Item No.	Component Description
1	Sleeve
2	Hex Head Screw
3	Spacer
4	Cylinder
5	Piston
6	End Cap
7	Snap Ring
8	Flange Bearing
9	Piston Rod
10	Hex Head Screw
11	Lockwasher
12	Lockwasher
13	Hose Assembly
14	Brake Shoe
15	Snap Ring
16	Pin
17	Brake Shoe
18	Friction Lining
19	Special Hex Nut
20	Front Drum Rotation Decal
21	Rear Drum Rotation Decal

Item No.	Component Description
22	Stop Nut
23	Trunnion Sub-Assembly
24	Rod Cover
25	Stop Nut
26	Flat Head Screw/Rivet
27	Spring Shield
28	Rod
29	Stop Nut
30	Washer
31	Spring Tube
32	Spring
33	Spring
34	Washer
35	Washer
36	Spring Sleeve
37	Pipe Nipple
38	Flow Valve Assembly
39	Ball Bushing
40	Stop Nut
41	Nameplate
42	Warning Plate

Airflex CTE Component Parts

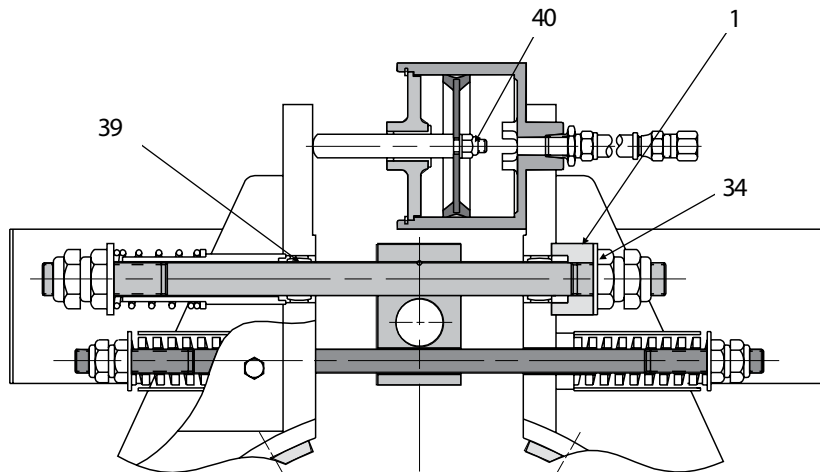
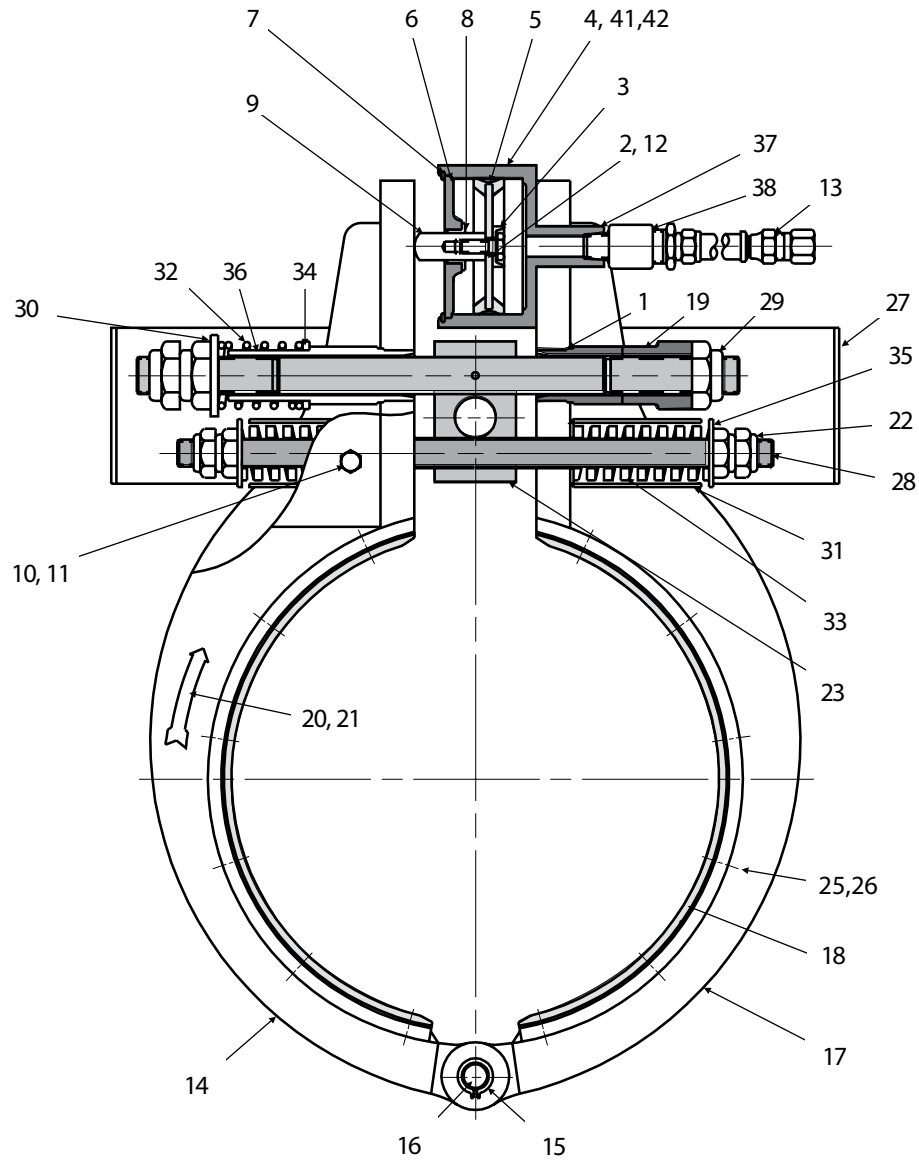

Airflex CS, CSA and CTE Brake Drums

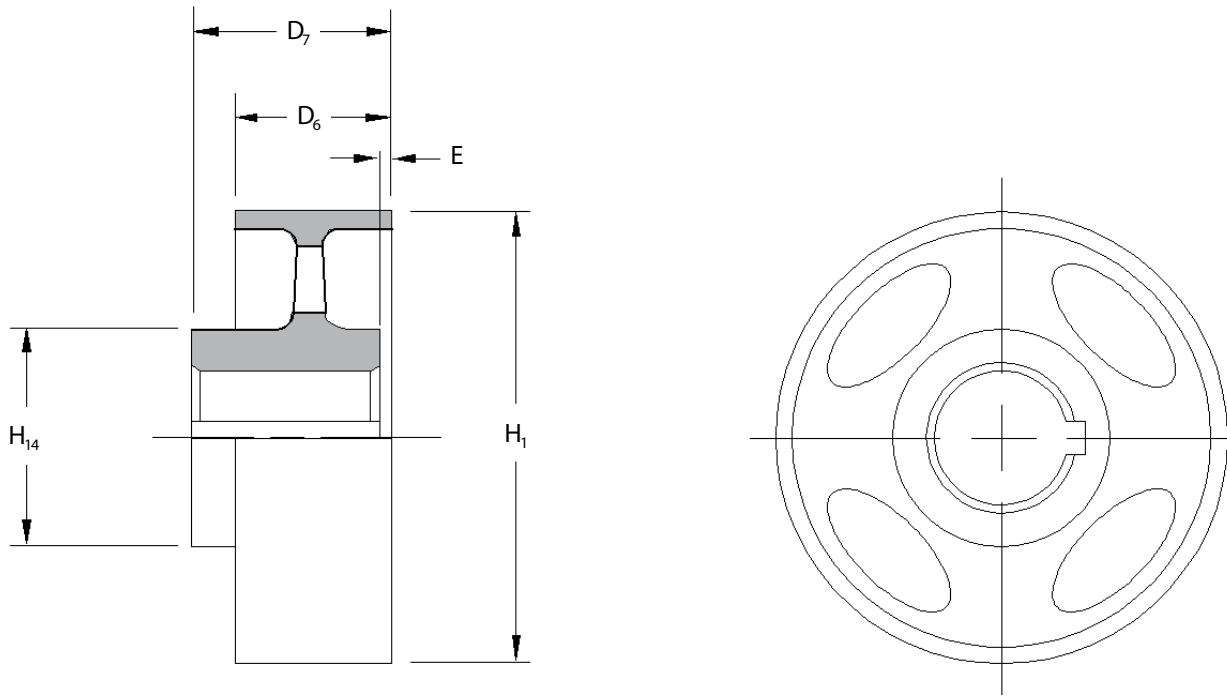

English		lb	lb-ft ²	Dimensions in inches						
4CS150	403875	6	0.1	1.00	1.88	2.00	4.25	-	4.00	3.00
6CSA200	10108	10	0.3	1.00	2.50	2.38	2.88	0.94	6.00	3.25
9CSA200	301259	25	1.5	1.50	2.75	2.50	4.00	1.00	9.00	4.50
12CSA200	302345	45	4.7	1.88	4.00	2.50	4.88	0.75	12.00	6.50
15CS300	301459	75	12	2.00	4.50	3.75	6.00	1.50	15.00	7.00
18CS300	402517	90	16	2.13	4.50	3.75	6.00	1.00	18.00	7.00
12CTE237	302518	45	4.7	2.00	4.00	2.63	4.88	0.75	12.00	6.50
18CTE300	402517	90	16	2.13	4.50	3.75	6.00	1.00	18.00	7.00
24CTE500	502340	437	129	4.50	6.00	5.75	8.50	-	24.00	10.50
Size	Part Number	Weight Mass	Wk ² J	Bore Range		D ₆	D ₇	E ③	H ₁	H ₁₄
				Min.	Max.					
4CS150	403875	2,7	0,004	25	48	51	108	-	102	76
6CSA200	10108	4,5	0,01	25	64	60	73	23,88	152	83
9CSA200	301259	11	0,06	38	70	64	102	25,40	229	114
12CSA200	302345	20	0,20	48	102	64	124	19,05	305	165
15CS300	301459	34	0,50	51	114	95	152	38,10	381	178
18CS300	402517	41	0,67	54	114	95	152	25,40	457	178
12CTE237	302518	20	0,20	48	102	64	124	19,05	305	165
18CTE300	402517	41	0,67	54	114	95	152	25,40	457	178
24CTE500	502340	198	5,42	114	152	146	216	-	610	267
SI		kg	kg·m ²	Dimensions in millimeters						

- Notes:**
- ① For two piece construction, use CB internal flange drum and drum hub.
 - ② Based upon minimum bores.
 - ③ This dimension is maximum and must be specified by customer.

Airflex Selection Procedure

Brake Torque and Thermal Capacities

General

Technical Section Y of the catalog contains useful information pertaining to the selection, mounting, alignment and control of clutches and brakes in general. Formulas, symbols and units are also identified. It is recommended that Section Y be reviewed before attempting to size a specific product for an application.

Brake Torque

The torque ratings are dependent upon the spring force, not a pressurizing media. However, a pressurizing media is required to compress the springs to release the brake. Minimum releasing pressures, as well as the maximum pressures which the releasing piston and cylinder can withstand, are given on the catalog pages.

Type CS brakes are unidirectional. Direction of rotation is important in their application and close attention must be given to both the forward and reverse torque requirements of the application.

Type CTE brakes develop slightly larger torque in the forward direction of rotation than in the reverse direction. If reverse torque is critical, brake selection should be based upon the reverse torque rating.

For all brake types, torque will decrease with lining wear, due to the longer piston travel required for engagement. Brake types CS and CTE have provision for periodical adjustment to maintain torque rating during the life of its lining.

Continuous Thermal Capacity

The spring-applied brakes covered in this section are generally not recommended for continuous slip applications. This type of application, requiring a spring-applied brake, is best handled by the caliper and water-cooled product lines.

Cyclic Thermal Capacity

Brake types CS and CTE were designed primarily for high cyclic stopping applications. Both brake types are capable of a maximum thermal capacity P_c of 0.012 HP/in² (0,0014kW/cm²).

Non-Cyclic Thermal Capacity

Non-cyclic thermal capacity is determined by the element's friction area, drum or disc mass, heat capacity and thermal conductivity. The properties of our standard solid discs and drums result in the limits indicated in the Non-Cyclic Energy Capacity Graph. An explanation on the use of this graph follows.

The thermal energy calculated for the load is adjusted to include the energy associated with accelerating or decelerating the components of the tentative clutch and/or brake selection. The adjusted thermal energy W_t is divided by the element's friction area A . Next, the average power loading P_{ave} is calculated from:

$$P_{ave} = \frac{P_t}{A}$$

The point $(W_t/A, P_{ave})$ is plotted on the graph. If the point falls below the appropriate product limit line, the selection will handle the thermal load. If it does not, an element having a greater friction area is required.

Airflex Selection Procedure

Thermal Capacities — Non-Cyclic Energy Capacity for Types CS & CTE

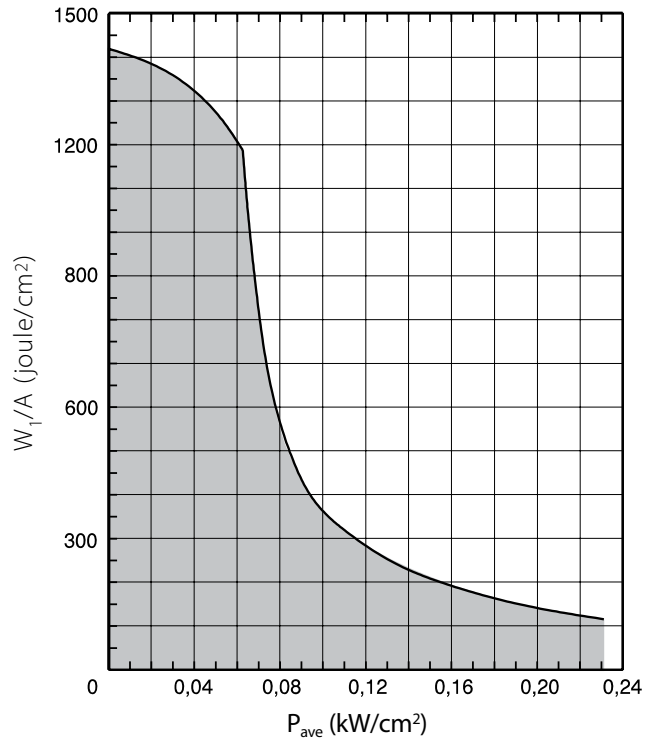
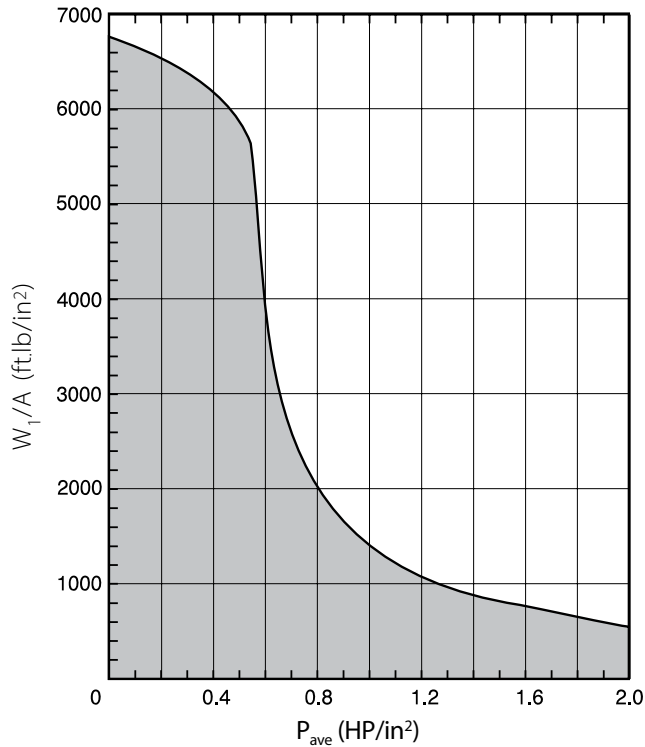

Example

A cyclic stopping brake is required for use on a power press operating under the following conditions. Determine the brake size and allowable cyclic rate.

Brake shaft speed: 250 rpm Stopping angle at crankshaft: 15°

Press stroke: 4 in

Ram and die weight: 600 lb

Reduction between brake shaft and crankshaft: 6:1

Stopping angle at brake shaft $\theta_d = 15^\circ \cdot 6 = 90^\circ$

$$t_d = \frac{\theta_d}{3n} = \frac{90^\circ}{3 \cdot 250} = 0.12 \text{ sec}$$

$$M_b = \frac{4WQ^2 \text{ lb-in}}{25.5 \text{ rev}} = \frac{50.250}{25.5} = 1.97$$

Reverse brake to 25.5 rev = 0.5-stroke-weight/

$$\text{reduction} = 0.5 \cdot 4 \cdot 600 / 6$$

$$= 200 \text{ lb-in}$$

From required torques, select 6CSA200

Lining area = 20 in²

Brake drum $WK^2 = 0.3 \text{ lb-ft}^2$

Total $WK^2 = 50 + 0.3 = 50.3 \text{ lb-ft}^2$

$$W = \frac{W k^2 \text{ in}^2}{5873} = \frac{50.3 \cdot 250^2}{5873} = 535 \text{ ft-lb}$$

$$P_c = \frac{W \cdot \text{cpm}}{33000}$$

$$\text{cpm} = \frac{P_c \cdot 33000}{W} = \frac{0.012 \cdot 20 \cdot 33000}{535} = 14$$

Products we offer:

- Cartridge valves
- DCV directional control valves
- Electric converters
- Electric machines
- Electric motors
- Gear motors
- Gear pumps
- Hydraulic integrated circuits (HICs)
- Hydrostatic motors
- Hydrostatic pumps
- Orbital motors
- PLUS+1[®] controllers
- PLUS+1[®] displays
- PLUS+1[®] joysticks and pedals
- PLUS+1[®] operator interfaces
- PLUS+1[®] sensors
- PLUS+1[®] software
- PLUS+1[®] software services, support and training
- Position controls and sensors
- PVG proportional valves
- Steering components and systems
- Telematics

Danfoss Power Solutions is a global manufacturer and supplier of high-quality hydraulic and electric components. We specialize in providing state-of-the-art technology and solutions that excel in the harsh operating conditions of the mobile off-highway market as well as the marine sector. Building on our extensive applications expertise, we work closely with you to ensure exceptional performance for a broad range of applications. We help you and other customers around the world speed up system development, reduce costs and bring vehicles and vessels to market faster.

Danfoss Power Solutions – your strongest partner in mobile hydraulics and mobile electrification.

Go to www.danfoss.com for further product information.

We offer you expert worldwide support for ensuring the best possible solutions for outstanding performance. And with an extensive network of Global Service Partners, we also provide you with comprehensive global service for all of our components.

Local address:

Hydro-Gear

www.hydro-gear.com

Daikin-Sauer-Danfoss

www.daikin-sauer-danfoss.com

**Danfoss
Power Solutions (US) Company**
2800 East 13th Street
Ames, IA 50010, USA
Phone: +1 515 239 6000

**Danfoss
Power Solutions GmbH & Co. OHG**
Krokamp 35
D-24539 Neumünster, Germany
Phone: +49 4321 871 0

**Danfoss
Power Solutions ApS**
Nordborgvej 81
DK-6430 Nordborg, Denmark
Phone: +45 7488 2222

**Danfoss
Power Solutions Trading
(Shanghai) Co., Ltd.**
Building #22, No. 1000 Jin Hai Rd
Jin Qiao, Pudong New District
Shanghai, China 201206
Phone: +86 21 2080 6201