

Installation, Operation and Maintenance of **Airflex[®] WCS Water Cooled Tensioners with Corrosion Resistant Components**



Warning

Forward this manual to the person responsible for Installation, Operation and Maintenance of the product described herein. Without access to this information, faulty Installation, Operation or Maintenance may result in personal injury or equipment damage.



Caution:

Use Only Genuine Airflex Replacement Parts

The Airflex Division of Danfoss recommends the use of genuine Airflex replacement parts. The use of non-genuine Airflex replacement parts could result in substandard product performance, and may void your warranty. For optimum performance, contact Danfoss.



ENGINEERING
TOMORROW

AN458477856895en-000101

Table of Contents

1.0 INTRODUCTION	2
1.1 Description	2
1.2 How it Works	2
2.0 INSTALLATION	3
2.1 Preparation	3
2.2 Mounting	4
2.3 Air Supply System	5
2.4 Coolant System	6
3.0 OPERATION	9
3.1 Conditions of Operation	9
3.2 Pressure and Speed Limits	9
3.3 Periodic Maintenance	9
4.0 MAINTENANCE	12
4.1 Wear Limits	12
4.2 Wear Adjustment & Disassembly	13
4.3 Dis-assembly Procedures	14
4.4 Friction Disc Replacement	15
4.5 Wear Plate Replacement	15
4.6 Cylinder Seal Replacement	17
4.7 Spring Replacement	18
4.8 Bushing Replacement	18
4.9 Assembly Procedures	18
4.10 Corrosion Protection	19
5.0 ORDERING INFORMATION/TECHNICAL ASSISTANCE	19
6.0 PARTS LISTS	20
7.0 REVISIONS	25

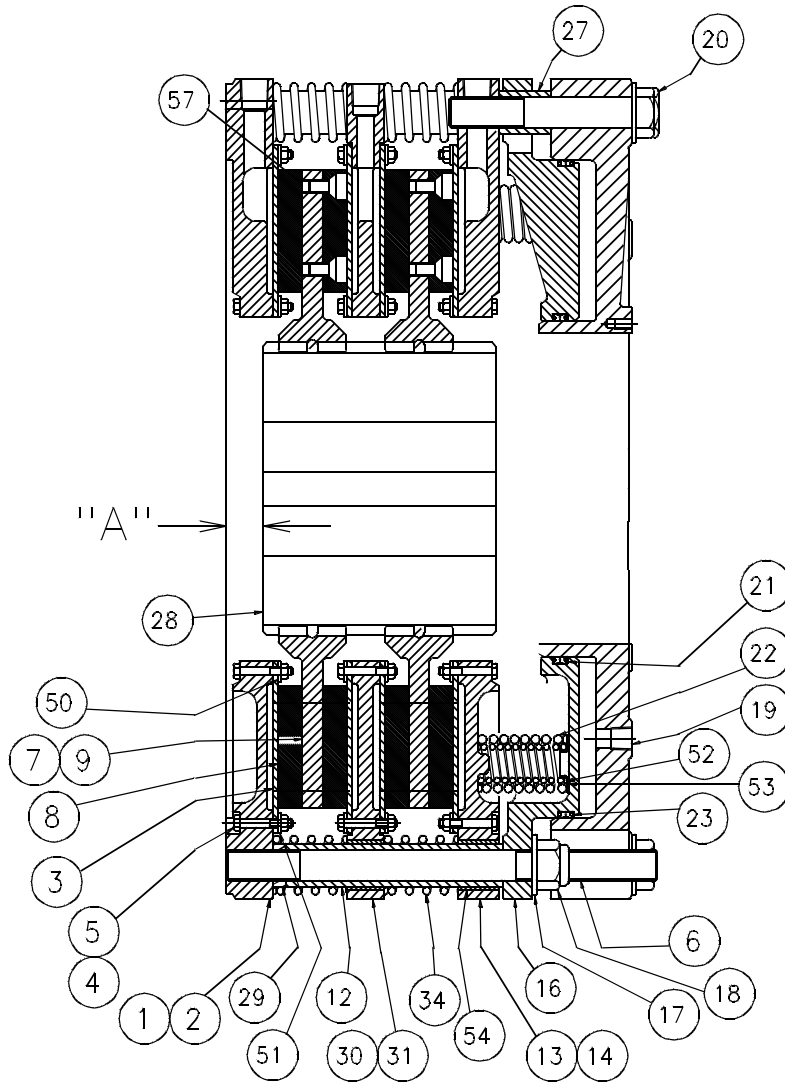



Figure 1

TABLE 1					
Item	Description	Item	Description	Item	Description
1	Mounting Flange Sub-Assembly	16	Spring Housing	28	Gear
2	Mounting Flange	17	Flat Washer	29	Wear Spacer
3	Wear Plate	18	Lock Nut	30	Reaction plate Sub-Assembly
4	Hex Head Screw	19	Cylinder	31	Reaction Plate
5	Locknut	20	Hex Head Screw	32	Decal Plate
6	Stud	21	Polypak Seal	34	Release Spring
7	Friction Disc Sub-Assembly	22	Spring	50	Inner Support Ring
8	Friction Disc	23	Polypak Seal	51	Outer Support Ring
9	Friction Disc Core	24	Warning Decal	52	Inner Spring
12	Clamp Tube	25	Name Plate	53	Spring Retainer
13	Pressure Plate S/A	26	Drive Screw	54	Bushing
14	Pressure Plate	27	Spacer Tube	57	Flat Head Screw

1.0 INTRODUCTION

Throughout this manual, there are a number of **HAZARD WARNINGS** that must be read and understood in order to prevent possible injury and/or damage to the equipment. Three signal words, "**DANGER**", "**WARNING**", and "**CAUTION**" are used to indicate the severity of a hazard and are preceded by the safety alert symbol .



Danger:

Denotes the most serious hazard, and is used when serious injury or death WILL result from misuse or failure to follow specific instructions.





Warning:

When serious injury or death MAY result from misuse or failure to follow specific instructions.



Caution:

When injury or product/equipment damage may result from misuse or failure to follow specific instructions.

It is the responsibility and duty of all personnel involved in the installation, operation and maintenance of the equipment on which this device is used to fully understand the  **Danger:**,  **Warning:**, and  **Caution:** procedures by which hazards are to be avoided.

1.1 Description

- 1.1.1 The Airflex WCS water-cooled tensioner is designed for constant tension applications. It is exceptionally well suited for high inertia stopping and rapid heat dissipation. The design of the WCS tensioner permits midshaft or endshaft mounting. The rugged construction ensures long, trouble free service. The corrosion protection provided with these units will help to ensure satisfactory operation when used in corrosive environments. The iron components are

painted with a marine epoxy coating. All other components are either coated or manufactured with corrosion resistant alloys. Several models are available having single and multiple friction discs. The tensioner model number identifies the number of discs and the disc diameter. For example, 124WCS means one 24" diameter disc. When size, such as 24WCS, is referred to in this manual, it means that the information given applies to all models using the 24" diameter disc; i.e., 124WCS, 214WCS, etc.

- 1.1.2 Tensioners can be used for either closed loop or open loop water systems.
- 1.1.3 This manual includes metric equivalents usually shown in () following the U.S. measurement system value. Be sure to use the correct value.

1.2 How It Works

- 1.2.1 Referring to Figure 1, the gear (28) is mounted on the shaft which is to be stopped and the tensioner assembly is attached to the machine frame or a reaction bracket. As air pressure is applied through the ports in the cylinder (19), the cylinder and pressure plate (13), which are attached to each other with screws (20), flat washers (17) and spacer tubes (27), move away from the mounting flange (2), which is connected to the machine frame or reaction bracket.

The pressure plate compresses the springs (22) and (53) against the stationary spring housing (16) and the clamp force is removed from the friction disc assembly (7) which rides on the gear. The shaft is then free to rotate. As air pressure is exhausted, the springs force the pressure plate toward the mounting flange, clamping the friction disc assembly between the two members. On dual disc models, an additional friction disc assembly and a reaction plate (30) are clamped between the pressure plate and mounting flange. High heat dissipation is accomplished by passing water through a special cavity behind copper alloy wear plates (3).

2.0 INSTALLATION



Warning:

Only qualified maintenance personnel should install, adjust or repair these units. Faulty workmanship will result in unreasonable exposure to hazardous conditions or personal injury.



Caution:

Read these instructions thoroughly and review until you fully understand the installation sequence before proceeding with the work described in this section. Failure to follow these instructions will result in unreasonable exposure to hazardous conditions or personal injury.



Caution:

Do not paint the clamp tubes (12) or the springs (34), as this may hinder the engagement or disengagement of the tensioner.



Caution:

Maximum ambient temperature is 110°F (43°C). Minimum ambient temperature for closed loop systems using ethylene glycol antifreeze is 0°F (-18°C). For open loop systems using water, the minimum temperature is 45°F (7°C).

Size	A
18WCS	1.25 (31.8)
24WCS	1.38 (35.0)
36WCS	2.38 (60.5)

Size	Female Register	Male Register
18WCS	18.250/18.253 (463.5/463.6)	23.250/23.247 (590.6/590.5)
24WCS	24.375/24.378 (619.1/619.2)	29.998/29.995 (762.0/761.9)
36WCS	18.375/18.378 (466.7/466.8)	44.498/44.493 (1130.2/1130.1)

Registers to be .125" - .188" (3.2 - 4.88 mm) deep.

Size	Concentricity of Shaft and Brake (Inches (mm))	Perpendicularity of Mounting Flange to Shaft (Inches (mm))
18WCS	0.010 (0.25)	0.010 (0.25)
24WCS	0.010 (0.25)	0.012 (0.30)
36WCS	0.010 (0.25)	0.019 (0.48)

2.1 Preparation

- 2.1.1 Table 2 shows the relationship between the tensioner mounting surface and the end of the gear (dimension "A" on figure 1). The gear is bored and keyed for a resulting Class FN2S interference fit for inch shafting and ISO System S7h6 for metric shafting.

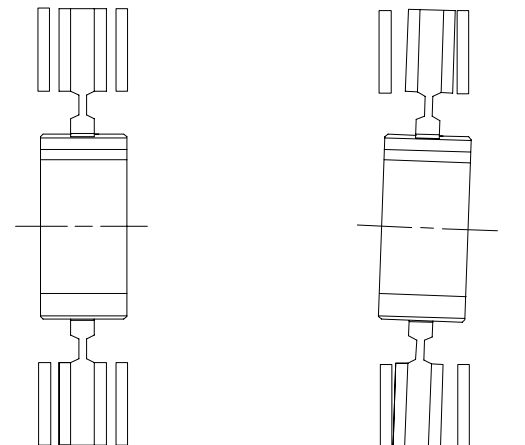

Correct Track

Incorrect Track

Figure 3

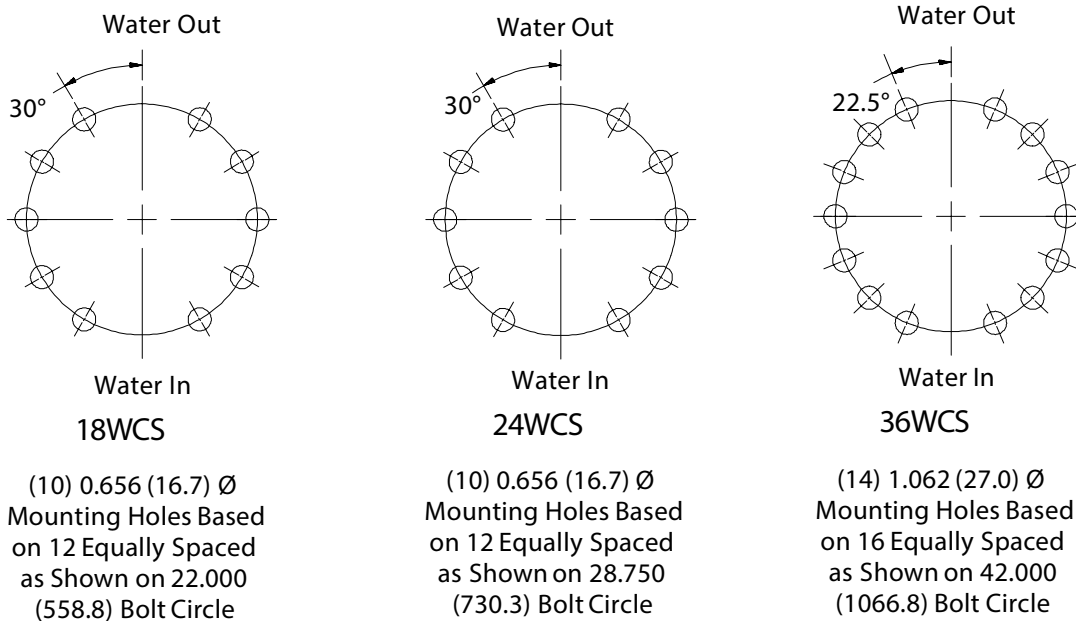

Figure 2

2.1.2 Figure 2 and Table 3 show the mounting dimensions for the tensioner to the machine frame or reaction bracket. Note that a male or female register may be used.

2.1.3 Alignment

2.1.3.1 For proper operation and service life, the tensioner reaction member must be aligned to the shaft within the limits shown in Table 4.



Proper alignment is necessary to ensure that the friction discs track properly. Improper alignment will result in excessive wear to the friction material and its mating surfaces, the gear and splined bore of the friction disc assembly. See Figure 3.

2.2 Mounting

Note: WCS brakes should be covered to protect the unit from dirt, rain, overspray, and other sources of external contamination. In extreme applications the use of a sealed enclosure with internal strip heater is recommended to prevent moisture from collecting on the unit.

2.2.1 The WCS must be mounted to a clean, rigid surface with hardened flat washers and screws of the grade, quantity, and size and torqued to the values identified in Table 5 for each WCS size. Mounting to a rigid surface minimizes any deflection during operation and ensures that the friction discs will track properly on the copper wear plates.



Water inlets and outlets must be in the 6 o'clock and 12 o'clock positions, respectively. See Figure 2. This will prevent air pockets in the water cavity, which would allow the tensioner to overheat.

TABLE 5

Fastener Description and Assembly Torque - ft.-lb. (Nm) Lubed				
Fastener		18WCS	24WCS	36WCS
Item #18	Description	3/4-10 NC-3 Gr. 8	1 1/8-7 NC Gr. 8	1 3/8-6 NC Gr. 8
	Torque	150 (203)	500 (677)	750 (1016)
Item #4	Description	5/16-18 NC Gr. 8	5/16-18 NC Gr. 8	3/8-16-NC2 Gr.8
	Torque	21 (28)	21 (28)	40 (54)
Item #20	Description	3/4-10NC-2 Gr. 8	1 1/8-7NC Gr. 8	1 3/8-6NC Gr. 8
	Torque	150 (203)	500 (677)	750 (1016)
Mounting Screw	Description	5/8-11NC-2 Gr. 8	5/8-11NC-2 Gr. 8	1-8 NC Gr. 8
	Quantity	10	10	14
	Torque	150 (203)	150 (203)	660 (895)

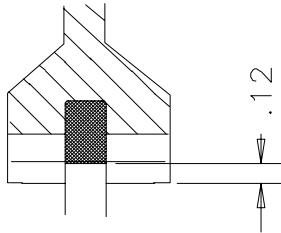

FILL GREASE CHANNEL 360° WITH MOLUB-ALLOY OPEN 412ES GEAR AND CABLE LUBRICANT TO WITHIN .12 OF I.D. AS SHOWN.

Figure 4



Use only the proper number and grade fasteners shown in Table 5. Use of commercial grade (Grade 2) fasteners where Grade 8 fasteners are specified may result in failure of the fasteners and a sudden and drastic reduction in brake torque.

- 2.2.2 Ensure that the shaft is free of nicks or burrs and the key fits properly in the shaft and gear.
- 2.2.3 Apply a light coat of anti-seizing compound to the shaft and key. Tap the key into the shaft keyway.

Note: On multiple disc brakes, before installing the gear onto the shaft, slide it into the brake assembly to align the splines on the friction disc assemblies. Air pressure must be applied to the brake to release the friction disc assemblies for alignment. Once the gear passes through all friction disc assemblies, exhaust the air to clamp them into position and remove the gear.

- 2.2.4 Press the gear onto the shaft, making sure that the dimension between the gear and the tensioner mounting surface ("A") is maintained. See Figure 1 and Table 2. Heating the gear uniformly to 250°F (121°C) will expand the bore and ease assembly.
- 2.2.5 Apply a thin coat of MOLUB-ALLOY® 412 ES grease to the gear teeth.



Excessive lubricant may contaminate friction material, resulting in erratic response or loss of torque.

- 2.2.6 Pre fill the grease channel in the friction disc splines with MOLUB-ALLOY® 412 ES greases shown on figure 4.
- 2.2.7 While supporting the brake, connect an air supply and apply enough pressure to release the brake. Attach the mounting flange (2) to the brake mounting surface using the appropriate fasteners. Torque the fasteners to the specified value. See Table 5.

2.3 Air System



Maximum allowable air pressure is 150 psig (10.2 bar). Operation of the WCS at pressures exceeding 150 psig may result in damage to the brake components.

TABLE 6 Air Inlet Sizes		
Size	Quantity	Air Inlet
18WCS	3	1/2 -14 NPT
24WC S		1/2 -14 NPT
36WC S		3/4 - 14 NPT

! Caution:

Minimum releasing pressure for low pressure brakes is 80 psig (5.5 bar) and for high pressure brakes is 90 psig (6.1 bar). Operation at pressures below minimum will result in brake drag and excessive heat and wear.

- 2.3.1 All pipes should be free of metal chips, cutting compound and any other foreign matter. Pipe ends should be reamed after cutting to eliminate possible restrictions. A minimum of bends and elbows should be used.
 - 2.3.1.1 The final connection to the brake inlet ports must be made with flexible hose.
 - 2.3.1.2 The WCS tensioner does not require lubricated air; however the solenoid valve may. Consult the valve manufacturer.
- 2.3.2 Air inlets for the WCS are on the face of the cylinder (19). Use only clean, filtered air (a 50 micron filter or better is recommended) which is free of excess moisture.
- 2.3.3 Air inlet sizes are shown in Table 6.

2.4 Coolant System

! Warning:

Maximum allowable water pressure is 40 PSIG (2.7 bar). Application of pressure exceeding maximum allowable may result in damage to the tensioner.

- 2.4.1 Coolant supply connections to the tensioner should provide a parallel flow through each section of the tensioner. Series flow is not recommended. Inlet and outlet coolant manifolds must be provided with flexible connecting hose to each tensioner coolant

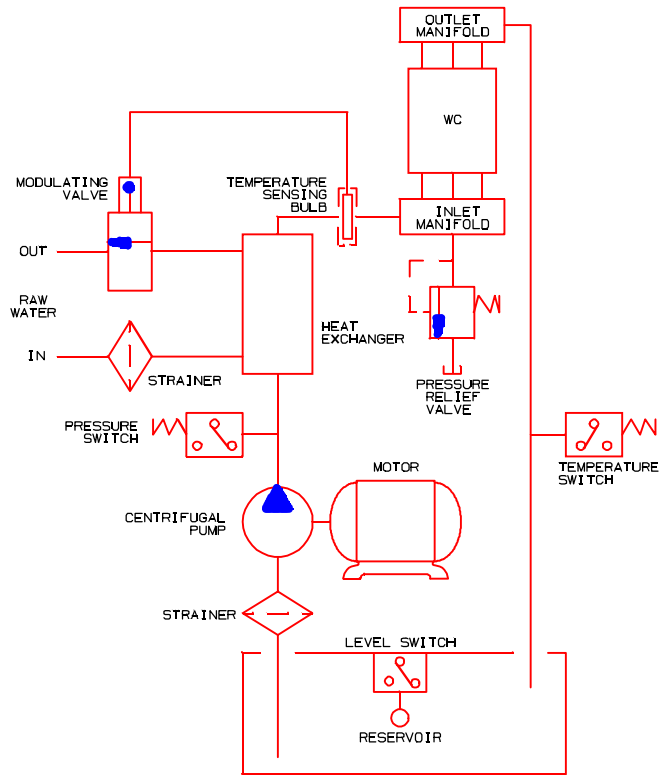

Figure 5

section. Coolant supply connection to the tensioner must be flexible to allow axial travel of the pressure plate and reaction plate during tensioner operation. Coolant and coolant supply lines should be free of foreign material (a 500 micron water filter is recommended). Reductions in the recommended line diameter should be avoided. Avoid loops and bends in the lines which may create air pockets, which substantially reduce the flow of coolant. Figure 5 illustrates a typical closed loop liquid to liquid coolant system. The heat exchanger and temperature control would be replaced with a radiator, fan and motor in a liquid to air system.

! Caution:

Make sure that the water inlets and outlets are at the 6 o'clock and 12 o'clock positions, respectively. See Figure 2. This will ensure that there will be no air pockets in the water cavity during operation, which would allow the tensioner to overheat.

TABLE 7							
Coolant Supply Data							
Size	Thermal Rating¹ HP (kW)	Water Inlet and Outlet Pipe Size	Min. Flow Rate³ GPM (dm³/min) Sea Water	Min. Flow Rate² GPM (dm³/min) 100% Water	Min. Flow Rate² GPM (dm³/min) 70% Water, 30% Ethylene Glycol by Vol.	Min. Flow Rate² GPM (dm³/min) 60% Water, 40% Ethylene Glycol by Vol.	Min. Flow Rate² GPM (dm³/min) 50% Water, 50% Ethylene Glycol by Vol.
118WCS	120 (89.4)	1/2-14NPT	14.5(54.5)	12 (45.4)	14 (53.6)	15.6 (58.8)	18 (67.9)
218WCS	240 (179)	1/2-14NPT	29 (109)	24 (91)	28 (106)	31(117)	36 (136)
318WCS	360 (268)	1/2-14NPT	43 (163)	36 (136)	42 (162)	47 (177)	54 (204)
124WCS	270 (201)	3/4-14 NPT	32.5(122.5)	27 (102)	32 (121)	35 (132)	40 (151)
224WCS	540 (402)	3/4-14 NPT	65(245)	54 (204)	64 (242)	70 (265)	80 (303)
324WCS	810 (603)	3/4-14 NPT	97 (365)	81(305)	96 (361)	105 (395)	120 (451)
424WCS	1080 (805)	3/4-14 NPT	130 (489)	108 (406)	128 (481)	140 (526)	160 (602)
136WCS	650 (485)	1 1/4-11 NPT	78(293)	65 (246)	76 (288)	84 (318)	98 (371)
236WCS	1300 (969)	1 1/4-11 NPT	156 (587)	130 (489)	152 (572)	168 (632)	196 (737)
336WCS	1950 (1454)	1 1/4-11 NPT	234 (880)	195 (738)	228 (863)	253 (958)	294 (1113)
436WCS	2600 (1937)	1 1/4-11 NPT	312(1173)	260(978)	304(1143)	336(1263)	392(1474)
1 - Thermal rating based on a 70°F (21°C) water inlet temperature and a 50°F (28°C) temperature rise between inlet and outlet.							
2 - Flow rate is based on requirement of 1 U.S. GPM per 10 HP (1.97 kW perdm ³ /min) thermal dissipation.							
3 - Flow rate when using Sea water is based on requirement of 1 U.S. GPM per 8 HP (1.58 kW per dm ³ /min) thermal dissipation. If sea water is used as a coolant, a 500 micron filter is recommended. After use, coolant cavities must be flushed with fresh (un-contaminated) water.							

TABLE 8	
Maximum Mixture Outlet Coolant Temperature	
Water/Ethylene Glycol Mixture % by Volume	Maximum Outlet Coolant Temperature °F (°C)
100/0	150 (66)
70/30	165 (74)
60/40	165 (74)
50/50	170 (77)

2.4.2 The coolant supply and discharge pipe sizes, along with minimum flow rates for the tensioner rated horsepower, are given in Table 7.

2.4.3 Each coolant cavity of each WCS tensioner has been statically tested at the factory before shipment. If leakage is suspected, a static or dynamic test may be performed as follows:

Static Pressure Test:

First, bleed all air from within the coolant cavity. Air bleeding must be accomplished by running coolant through the cavity with the tensioner secured in its operating position.

After the air has been removed, install a pipe plug in the outlet and apply 40 PSIG (2.7 bar) coolant pressure measured at the inlet to the water cavity. Maintain this pressure for 30 minutes. Check for leakage at O.D. and I.D. seal areas.



Caution:

Be sure to apply air pressure to the cylinder of the tensioner to release the spring pressure on the tensioner during static coolant pressure testing. Surge pressures exceeding 40 PSIG (2.7 bar) could be developed within the coolant cavities which will cause damage to the seals.

Dynamic Flow Test:

Dynamic flow testing of the tensioner should be conducted at the required flow rate for the rated HP dissipation and coolant quality, as given in Table 7. Inlet pressure is not to exceed 40 PSIG (2.7 bar).

There should be no restrictions on the outlet side of the brake to cause any back pressure to the unit. Coolant inlet and hose size should be as given in Table 7. Check for leakage at the O.D. and I.D. seal areas.

2.4.4 The coolant supply temperature at the inlet should be 100°F (38°C) or lower. The coolant outlet temperature should not exceed the values given in Table 8. However, in no event should there be more than a 50°F (28°C) temperature rise between inlet and outlet. See Table 8 for maximum allowable outlet coolant temperature with a water/ethylene glycol mix.

2.4.5 **Open Loop Systems**

For efficient operation of the WCS, an adequate supply of filtered fresh water is required. (See 2.4.1-2.4.2). Excessive water hardness promotes the formation of scale deposits, which, in time, will affect the service life of the WCS unit. Water of high acidity may cause electrolytic corrosion between the dissimilar metals used in the WCS. Water treatment should be considered if the properties of the water exceed the following:

Equivalent calcium carbonate content (hardness): Maximum 100 p.p.m.

pH value: 7.0 to 9.0.

2.4.6 **Closed Loop Systems**

For efficient operation of the WCS in a closed loop system, ethylene glycol coolant conforming to SAE Standard J1034 should be used. For preparation of the proper concentration of a water/ethylene glycol mixture, use make-up water which is low in corrosive ions such as chlorides and sulfates.

pH value of the water/ethylene glycol mixture: 7.5. to 10.5.

TABLE 9		
Maximum Disc Speeds		
Size	Max. Slip Speed RPM	Max. Free Wheeling Speed RPM
18WCS	955	1590
24WCS	715	1200
36WCS	475	700

3.0 OPERATION

3.1 Conditions of Operation

The following Hazard Warnings are to be followed for proper WCS functioning:

 **Warning:**

Protective means must be used to prevent oil, grease, dirt or coolant from coming into contact with the surfaces of the friction discs (8) or the wear plates (3). Oil or grease on these parts will significantly reduce the torque capacity of the unit. Dirt or coolant will produce erratic torque. Do not risk personal injury or damage to the equipment!

 **Warning:**

The friction disc assembly (7) maximum free wheeling speed must not exceed the speeds listed in Table 8. Exposure to speeds in excess of these values may cause the friction discs to burst and result in extensive damage to the tensioner and/or cause personal injury.

 **Caution:**

For proper cooling of the WCS tensioner, it is required that the coolant inlet be located at the 6 o'clock position and the outlet be located at the 12 o'clock position. This will assure that all coolant cavities are filled and will prevent overheating. Refer to Figure 2.

 **Caution:**

For operation in subfreezing temperatures, ethylene glycol antifreeze must be added to the water. The antifreeze content of the mixture is critical and should not exceed 50% by volume since excessive amounts will reduce cooling capacity and can cause coolant leakage due to overheating. Refer to Section 2.4.4 and Table 8.

 **Caution:**

A minimum wear in period of four hours at 50% of the rated horsepower is recommended for the friction couple.

3.2 Pressure and Speed Limits

3.2.1 Maximum slip speeds and free wheeling disc speeds are shown in Table 9.

 **Caution:**

Excessive slip speeds will result in rapid friction material wear. For good life, the values in Table 9 should not be exceeded.

3.2.2 Maximum applied pressure is 150 psig (10.2 bar). Minimum releasing pressure for low pressure brakes is 80 PSIG (5.5 bar). Minimum releasing pressure for high pressure brakes is 90 psig (6.1 bar).

3.3 Periodic Maintenance

3.3.1 Periodically check for air leakage in the area of the cylinder seals (21,23). For replacement, refer to Section 4.0 MAINTENANCE.

3.3.2 Periodically observe the friction disc assembly(s) with the brake released. Dragging friction discs may be caused by wear or contamination at the gear-friction disc core contact areas or misalignment.

3.3.3 Pneumatic and electrical control interlocks should be periodically checked for correct settings and operation.

TABLE 10			
Wear Limits for WCS Components			
Item	Description	Wear Limit	Remarks
#8 Friction Disc	Friction Material	Fully worn at bottom of wear groove. See Figure 6. Friction material must also be replaced if contaminated with oil or grease.	Multi-disc units have adjustment provision. See 4.2.
#3 Wear Plate	Friction Wear Surface	Maximum wear is: 18 WCS - 0.030" 24 WCS - 0.045" 36 WCS - 0.050"	Wear will be in form of circular grooves in copper surface.
#19 Cylinder	Seal Area	Maximum wear is 0.005" (0.13 mm).	Wear will be in the form of grooves where the seals contact.
#14 Pressure Plate	Reaction Holes	Maximum wear is 0.031" (0.80 mm).	Wear will be in the form of elongation of the holes. Original hole diameters are shown in Table 10A.
#31 Reaction Plate	Reaction Holes	Maximum wear is 0.031" (0.80 mm).	Wear will be in the form of elongation of the holes. Original hole diameters are shown in Table 10A.
#12 Clamp Tube	Reaction Area	Maximum wear is 0.015" (0.38 mm).	Wear will be in the form of a notch or step on the side of the tube.

TABLE 10A	
Original Reaction Hole Diameters In Pressure Plate and Reaction Plate	
Size	Diameter - In (mm)
18WCS	1.312 (33.33)
24WCS	1.688 (42.88)
36WCS	2.376 (60.35)

TABLE 10B	
Original Spring Free Height	
Size	Free Height - In. (mm)
18WCS	4.44 (112.8)
24WCS	Inner 4.8 (122) Outer 4.76 (121)
36WCS	Inner 6.78 (172.2) Outer 6.65 (169)
Minimum Spring Free Height	
Size	Free Height - In. (mm)
18WCS	4.25 (108)
24WCS	Inner 4.61(117) Outer 4.57(116)
36WCS	Inner 6.4 (162) Outer 6.3(160)

Table 11

X & Y Dimension Limits

WCS Size	Min X (New) In. - (mm)	1.)Max X - In. (mm)	2.)Min Y ₁ - In. (mm)	3.)Min Y ₁ - In. (mm)	4.)Min Y ₂ - In. (mm)	5.) Min Y ₃ - In. (mm)
118	0.08 (2.03)	0.52 (13.3)	1.44 (36.58)			
218	.16 (4.064)	0.60 (15.3)	N/A	1.54(39.12)	1.54(39.12)	
318	Available at later date					
124	0.09 (2.29)	0.53 (13.4)	2.42 (61.47)			
224	0.18 (4.57)	0.97 (24.6)	N/A	2.25 (57.15)	2.07 (52.58)	
324	Available at later date					
424						
136						
236						
336	.30 (7.6)	.969 (24.6)	N/A	2.33 (59.18)	2.33 (59.18)	2.33 (59.18)
436	Available at later date					
1.) X is the maximum gap between spring housing (16) and pressure plate (14).						
2.) Y dimension is the minimum distance allowed between the mounting flange and pressure plate.						
3.) Y ₁ dimension is the minimum allowable distance between the mounting flange and the reaction plate.						

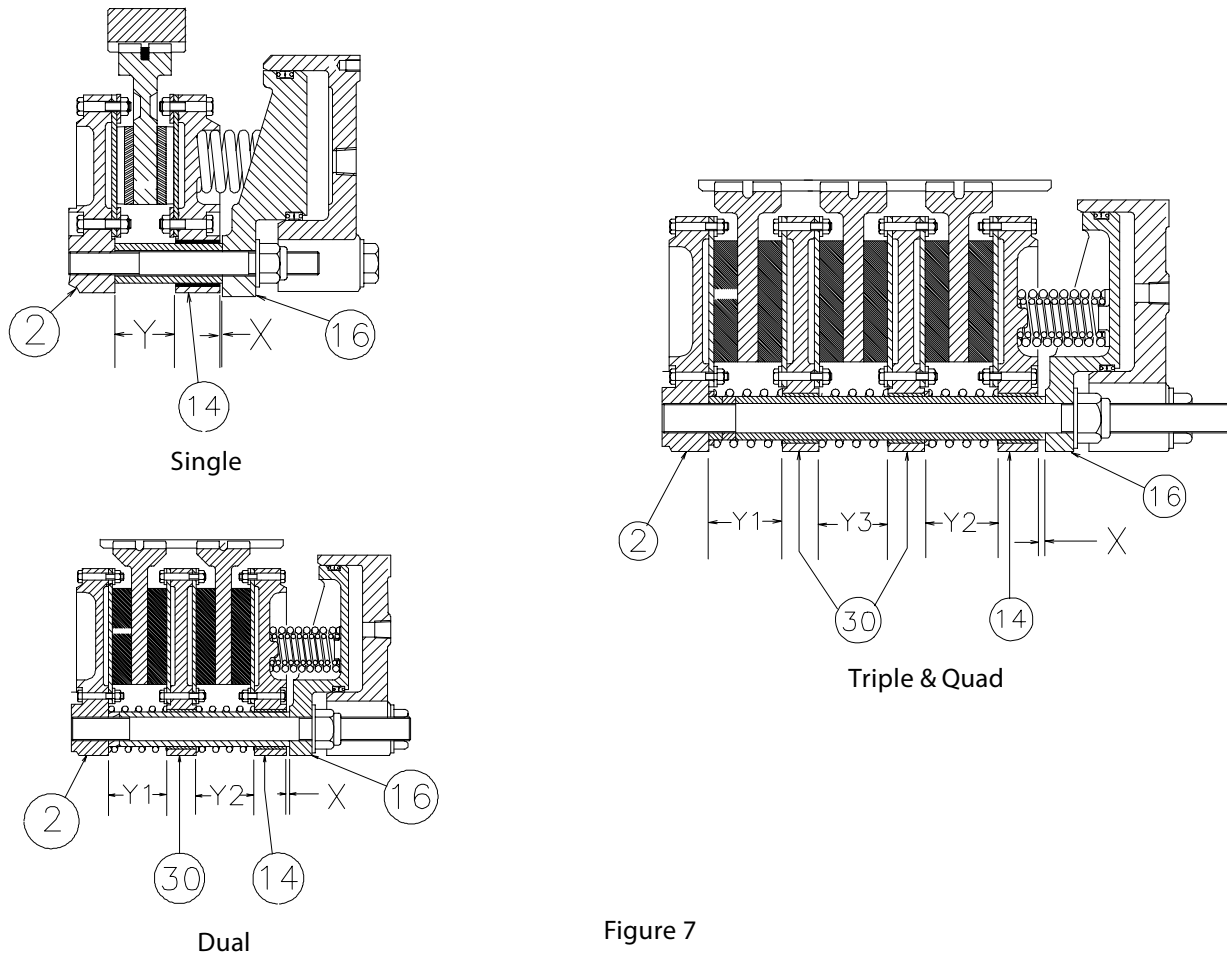

Figure 7

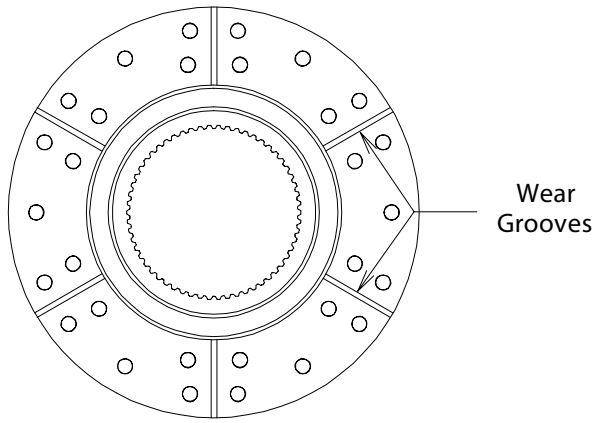

Figure 8

4.0 MAINTENANCE

Warning:

Before doing any maintenance work on the WCS unit, make sure that the machinery will remain in a safe position. Failure to do so could result in serious injury or possibly death.

Warning:

Only qualified maintenance personnel should install, adjust or repair these WCS units. Faulty workmanship will result in unreasonable exposure to hazardous conditions or personal injury.

Caution:

Read these instructions thoroughly and review until you fully understand the parts replacement steps before proceeding with the work described in this section. Failure to follow these instructions can result in unreasonable exposure to hazardous conditions or personal injury.

Model	Nut Size	Socket Depth
118 WCS	1 1/16"	2"
218 WCS	1 1/16"	2 1/4 "
318 WCS	Available at a later date	
124 WCS	1 5/8"	3"
224 WCS	1 5/8"	6"
324 WCS	Available at a later date	
424 WCS		
136 WCS		
236 WCS		
336 WCS	1 5/8"	6"
436 WCS	Available at a later date	

4.1 Wear Limits

Warning:

Periodically examine the tensioner for wear of linings and wear plates. Failure to perform this examination will result in excessive wear, a significant reduction in torque, and may result in personal injury and/or damage to the machinery.

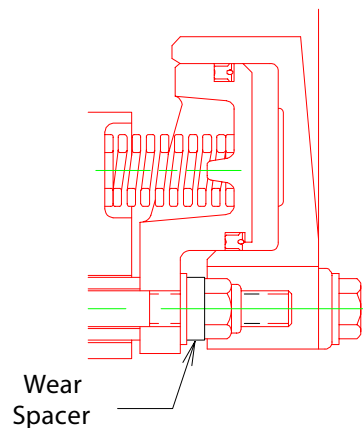

Figure 9

4.1.1 Wear limits for the WCS components are shown in Table 10. If any wear limit has been reached or exceeded, that component must be repaired or replaced.

4.1.2 **Single Disc Units**

Exhaust all air from the cylinder to engage the tensioner. Measure the gap "X" between the spring housing (16) and the pressure plate (14) and the gap "Y" between the pressure plate (14) and the mounting flange (2) as shown in Figure 6. If either gap exceeds the limits shown in Table 11, the friction discs and/or wear plates must be inspected to ensure that the wear limits listed in Table 10 have not been exceeded.

4.1.3 **Multiple Disc Units**

Exhaust all air from the cylinder to engage the tensioner. Measure the gap "X" between the spring housing (16) and the pressure plate (14) or the gap "Y₁" between the mounting flange (2) and the reaction plate (30) and the gap "Y₂" between the reaction plate (30) and the pressure plate (14) and the gap "Y₃" between reaction plates as shown in Figure 7. If any gap exceeds the limits shown in Table 11, the friction discs and/or wear plates must be inspected to ensure that the wear limits listed in Table 10 have not been exceeded.

4.2 **Wear Adjustment**

Determining Wear

4.2.1 On both single and multiple disc units, the friction material must be replaced when worn to the bottom of the groove on the friction lining (see figure 8) or any "Y" dimension exceeds the limits shown on Table 11. On multi-disc units, however, a wear adjustment is required when the "X" dimension is exceeded but the "Y(s)" dimension(s) are not worn to their limits.



Warning:

If a wear adjustment is not made, the brake torque may deteriorate to the point where the equipment will not stop properly.

Single disc units

Exhaust all air from the cylinder to engage the tensioner. Measure the gap "X" between the spring housing (16) and the pressure plate (14) and the gap "Y" as shown in Figure 7. If either dimension exceeds the limit in table 11 repair is required. Dis-assemble the unit per section 4.3 and inspect and replace parts in accordance with the wear limits on table 10.

Multi disc units

Exhaust all air from the cylinder to engage the tensioner. Measure the gap "X" between the spring housing (16) and the pressure plate (14) to determine if adjustment is required. Measure the gap "Y₁" between the mounting flange (2) and the reaction plate (30) and the gap "Y₂" between the reaction plate (30) and the pressure plate (14) and gap Y₃ as shown in Figure 7. If the "X" dimension is exceeded but any of the "Y" dimensions are less than the limits shown in Table 11 **AND** none of the friction discs are worn to the bottom of the wear groove, adjustment is required.

Adjustment Procedure

- 4.2.1.1 Disconnect the air supply lines and water lines from the tensioner.
- 4.2.1.2 While supporting the cylinder (19), loosen the locknuts (18) **ONE TURN AT A TIME** and in an alternating (cross wise) pattern until the release spring tension is released.



Caution:

The locknuts (18) must not be loosened unless the screws (20) are in place retaining brake spring tension.

- 4.2.1.3 Remove the locknuts (18) and washers (17) and slide the cylinder (19), spring housing (16) and pressure plate sub-assembly (13) off of the studs as an assembly. Set aside in a clean area making sure not to damage the copper wear surface on the pressure plate. Refer to table 12 for proper socket size.



Caution:

Take care not to bump or jar power-pak to prevent spring housing from rotating within cylinder.

Note: If a stud (6) should happen to come loose, remove it completely, clean the threads on the stud and the threads in the mounting flange. Apply Loctite® Primer Grade "T" to the stud threads. After the threads have dried, assemble to the mounting flange using Loctite® #262. The end of the stud must not extend past the mounting surface on the mounting flange.



Caution:

Loctite® #262 must be shaken prior to application.



Caution:

Loctite® #262 may irritate sensitive skin. Refer to the product label for proper safety precautions.

- 4.2.1.4 Remove all friction disc assemblies, the reaction plate sub-assemblies (30) and the release springs (34) and set aside.
- 4.2.1.5 Slide the clamp tubes (12), and wear spacers (29) off of the studs. Reinstall the clamp tubes and enough wear spacers (29) to achieve new "X" dimension shown on Table 11.
- 4.2.1.6 Place a release spring over every other clamp tube and slide the reaction plate onto the clamp tubes.
- 4.2.1.7 Clean off old grease. Apply a light coat of Molub-Alloy® 412 ES to the gear teeth and clean and fill the friction disc groove in the spline and fill with Molub-alloy® 412 ES as shown in figure 4. Slide the friction disc assembly onto the gear.

- 4.2.1.8 Place a release spring onto every other clamp tube and slide the pressure plate/cylinder assembly onto the clamp tubes.

- 4.2.1.9 Lubricate the threads on the ends of the studs with 30 wt. oil or anti-seizing compound and install the locknuts (19), washers (18) and the wear spacers removed in 4.2.1.5. The wear spacers are "stored" under the locknuts for use after replacing friction discs. See Figure 9.

- 4.2.1.10 While supporting the weight of the cylinder/spring housing/pressure plate assembly, tighten the locknuts, **ONE TURN AT A TIME** and in a crosswise pattern, until the spring housing is seated against the clamp tubes. Torque the locknuts to the appropriate value. See Table 5.



Caution:

The locknuts (18) must be tightened gradually to prevent damage to the brake components.

- 4.2.2 Reinstall the air and water lines per 2.0.

4.3 Dis-assembly Procedures

- 4.3.1 Disconnect the air supply lines and water lines from the tensioner.
- 4.3.2 Remove the fasteners which mount the brake to the mounting adapter.
- 4.3.3 Using soft slings, rig the tensioner and slide the brake off of the gear.
- 4.3.4 Transport tensioner to a clean working area and position the brake mounting flange down.
- 4.3.5 If the gear requires replacement, remove it with portable jack, using the threaded holes in the end of the gear for puller holes. Heating may be required to ease removal. Replace gear and install per Section 2.2.
- 4.3.6 **ONE TURN AT A TIME**, and in an even, alternating sequence, remove the screws (20), washers (17) and spacer tubes (27) attaching the cylinder (19) to the pressure plate (13).

- 4.3.7 Carefully slide the cylinder off of the spring housing (16).
- 4.3.8 Loosen the locknuts (18) ONE HALF TURN AT A TIME and in sequence until the release spring force is relieved. Refer to Table 12 for proper socket size.



Caution:
The locknuts (18) must not be loosened unless the screws (20) are in place retaining brake spring tension.

- 4.3.9 Remove the spring housing(16), springs (22)(52), spring retainers(53), pressure plate (13), release springs (34), friction discs (7), reaction plates(30)(except single disc), clamp tubes,and wear spacers.



Caution:
Do not use compressed air to remove the cylinder from the spring housing.

- 4.3.10 Refer to Section 4.6.3 to replace seals.
- 4.3.11 For friction lining replacement refer to Section 4.4.
- 4.3.12 For wear plate replacement refer to Section 4.5.
- 4.3.13 For spring replacement refer to Section 4.8.
- 4.3.14 Inspect all components using the wear limits in Table 10.
- 4.3.15 Assemble the tensioner per Section 4.9.

4.4 Friction Material Replacement

- 4.4.1 Friction disc cores may be relined with new friction material per the following instructions. Refer to Section 6.0 for the appropriate friction disc replacement part numbers and kit numbers.



Caution:
Use only genuine Airflex friction material. Use of material not of Airflex origin may result in unpredictable performance.

- 4.4.2 Dis-assemble the brake per Section 4.3
- 4.4.3 Remove old screws and remove and discard the old friction material.
- 4.4.4 Clean all burrs, corrosion etc.. from friction disc cores.
- 4.4.5 Position friction material to the disc core and apply the specified Loctite[®] and torque to value shown in Table 13.



Caution:
Use only Airflex-supplied screws.



Caution:
Loctite[®] #242 & #262 must be shaken prior to application.



Caution:
Loctite[®] #242 & #262 may irritate sensitive skin. Refer to the product label for proper safety precautions.

- 4.4.6 Assemble the tensioner per Section 4.9.

4.5 Wear Plate Replacement

- 4.5.1 Dis-assemble tensioner per Section 4.3.
- 4.5.2 Remove the screws and locknuts holding the wear plates and remove the wear plates. If the wear plates cannot be easily lifted off, gently tap the O.D. to break the gasket seal.



Caution:
Do not attempt to break the gasket seal by prying between the wear plate and housing. Damage to the sealing surfaces may occur.

Table 13		
Friction Disc Screw Torque		
Model	18 WCS	24 & 36 WCS
Part Number	000422x0008	000421x0407
Screw Size	1/4"-28 UNRF	1/2"-13NC2
Torque [®]	75 in. lbs.	15 ft. lbs.
Loctite	#242	#262

4.5.3 Inspect the water passages and, if necessary, use a wire brush to clean them. If repainting is necessary, sand blast the water passages and paint the surfaces with Glid Gard® Epoxy 5256/5257 or equivalent. Dry film thickness should be 0.007" (0.18 mm). Be careful not to allow the paint to get into the seal grooves or onto the nubs.

! Caution:

If nubs are severely corroded, wear plates may not be properly supported. Replace pressure plate, reaction plate or mounting flange, if necessary.

4.5.4 Clean and completely dry the gasket surfaces on the pressure plate (14), reaction plate(s) (30) and mounting flange (2). These surfaces should be free of nicks and scratches to prevent leaks. Nicks and scratches may be filled with Loctite/Permatex® High Temperature Silicon Form-A-Gasket Sealant, RTV Red Gasket Maker or the equivalent.

4.5.5 Apply a uniform bead of Loctite Superflex® #596 Silicon Sealant in the grooves of the pressure plate, reaction plate(s) and/or mounting flange. Recommended bead diameter is 0.060" - 0.090" (1.5 mm - 2.3 mm).

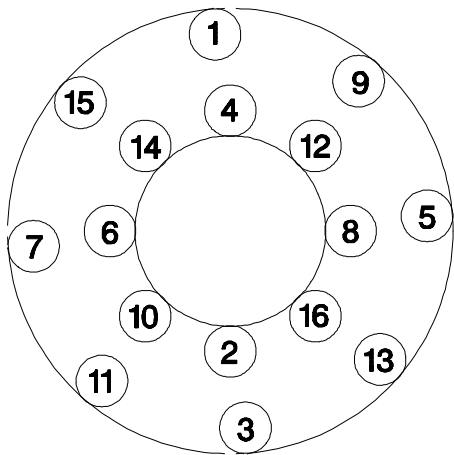

Figure 10

4.5.6 Inspect the new wear plates and remove any scratches or raised edges with very fine sandpaper or steel wool. Position the smoothest side of the wear plate on the mating surface being careful to align the holes.

! Caution:

Loctite Superflex® #596 Silicon Sealant will begin to set up and skin over in approximately 10 minutes. The wear plate must be fastened to the mating component within 10 minutes of applying the sealant.

4.5.7 Install the new screws and locknuts provided with the wear plate replacement kit and secure finger tight.

! Caution:

To prevent excessive warpage and to ensure a good seal, the following hardware tightening procedure must be followed.

4.5.8 For each wear plate being replaced, follow the tightening sequence shown in Figure 10 for the first 16 screws. The remaining screws may be tightened in any reasonable crosswise pattern. See Table 5 for tightening torques.

TABLE 14		
Wear Plate Replacement Kits		
Size	Kit Part Number	
	Basic Kit ¹	Reaction Plate Kit ²
18WCS	107726N	107726O
24WCS	107727N	107727O
36WCS	107662N	107662O
1 - Single disc units require one basic kit only		
2 - Multiple disc units require one basic kit and one reaction plate kit per reaction plate in tensioner.		
Example: A 214WCS requires one basic kit (107672N) and one reaction plate kit (107672O)		



Caution:

Allow the Loctite Superflex® #596 Silicon Sealant 24 hours to completely cure before performing the following leak test procedure.

- 4.5.9 24 hours after completion of assembly, each water cavity should be checked for leaks.
 - 4.5.9.1 Using lifting straps, suspend each assembly with the water outlet port at the 12 o'clock position. Connect a water supply line to the inlet port (at 6 o'clock position). See Table 7 for water port size.
 - 4.5.9.2 Slowly fill with water to purge all air from water cavities.
 - 4.5.9.3 Install a pipe plug in the outlet port and apply 45 PSIG (3.1 bar) water pressure measured at the inlet. Maintain this pressure for 30 minutes.
 - 4.5.9.4 Check for leakage at O.D. and I.D. seal areas. **NO** leakage is allowed.
 - 4.5.9.5 If the assembly leaks, check the torque on each screw and retest. If leaks still occur, the wear plate(s) may be damaged. Repeat procedure from 4.5.1.
 - 4.5.9.6 Follow steps in section 4.9 to reassemble the tensioner.

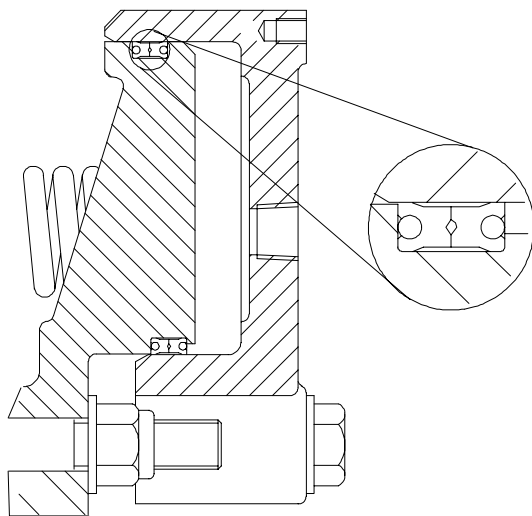

Figure 11

4.6 Cylinder Seal Replacement

- 4.6.1 Disconnect the air supply lines and remove the screws (20), washers (17) and spacer tubes (27) attaching the cylinder (19) to the pressure plate (13).
- 4.6.2 Carefully slide the cylinder off of the spring housing (16).



Caution:

Do not use compressed air to remove the cylinder from the spring housing.

- 4.6.3 Remove the cylinder seals (21,23) from the spring housing and thoroughly clean the seal grooves in the spring housing.
- 4.6.4 Insert new seals into the grooves, noting the orientation of the seals per Figure 11.
- 4.6.5 Carefully examine the seal surfaces in the cylinder. If the surfaces have worn to point as indicated on Table 10, the cylinder must be replaced. Small nicks or scratches must be sanded smooth to prevent air leakage. **If tensioner was completely removed and dis-assembled refer to section 4.9 to assemble.**
- 4.6.6 Lubricate the seal surfaces in the cylinder with Parker O-Lube® and carefully slide the cylinder onto the spring housing. Take special care to avoid damaging the seal lips.
- 4.6.7 Attach the cylinder to the pressure plate with the screws, washers and spacer tubes removed in 4.6.1. Use Loctite® Locquic® Primer Grade "T" to clean and prepare the screw threads and install with Loctite® #262. Using a crosswise pattern, torque the screws to the value shown on Table 5.

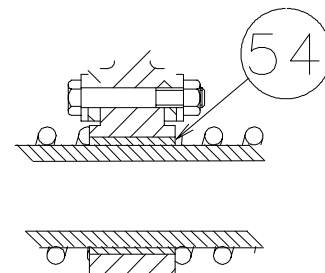

Figure 12



Warning:

Loctite® Primer "T" contains harmful vapors. Refer to the product label for proper safety precautions.

4.6.8 Install air lines.

4.7 Spring Replacement

4.7.1 Dis-assemble per section 4.3.

4.7.2 Inspect the springs for distortion and check the free height. If the free height of any spring is less than the value shown on Table 10B, the entire set of springs must be replaced.

4.7.3 Assemble brake per section 4.9.

4.8 Bushing Replacement

4.8.1 Dis-assemble per section 4.3.

4.8.2 Refer to Table 10 to determine if the reaction plate bushings (54) (see figure 12) require replacement.

4.8.3 Heat up area around bushing to release Loctite® and drive old bushing out.

4.8.4 Clean out bores and remove old Loctite®.

4.8.5 Apply Loctite® #RC601, 635 or 680 to the bushing O.D. and mating hole in the reaction plate using a swab. Apply enough liquid to fill all the space between the parts. Twist the bushing while pushing it down, until it is flush with the casting surface. Inspect to see that the ring of liquid adhesive visible at the parting line. Allow reaction plate to dry for 15 minutes before moving it.

4.8.6 Assemble brake per section 4.9.

4.9 Assembly Procedures

NOTE: Wear spacers (29) and reaction plates (30) not used on single disc models

4.9.1 Orient the mounting flange so the studs (6) are in a vertical position.

4.9.2 Install wear spacers (29) and clamp tubes (12) over the studs.

4.9.3 Place a release spring (34) over every other clamp tube.

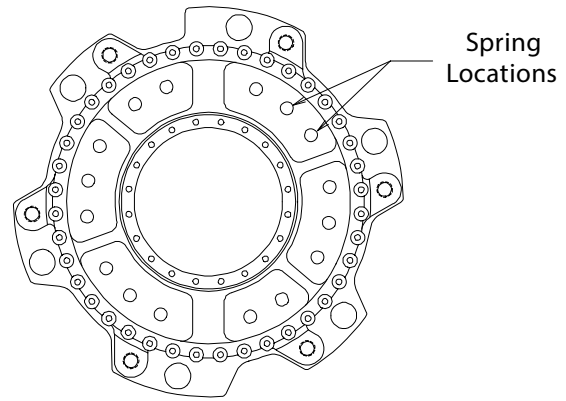

Figure 13

4.9.4 Pre-fill the grease channel in the friction disc splines with MOLUB-ALLOY® 412 ES grease as shown on Figure 4, and place the friction disc assembly on the mounting flange, centered in position.

4.9.5 On multiple disc assemblies, install a reaction plate(31), noting the position of the water inlet. Place release springs over every other clamp tube. Repeat Sections 4.9.3 through 4.9.5 for 3 and 4 disc models until all friction discs and reaction springs are installed.

4.9.6 Position the pressure plate (13) on top of the last friction disc, again noting the position of the water inlet.

4.9.7 Place the springs into the pockets in the pressure plate, per Figure 12.

4.9.8 Carefully lower the spring housing assembly onto the springs, making sure the springs engage the bosses in the spring housing.

4.9.9 Lubricate the threads on the ends of the studs with 30 wt. oil or anti-seizing compound and install the locknuts (18), washers (17) . Refer to Table 12 for proper socket size.

4.9.10 Tighten the locknuts, **ONE HALF TURN AT A TIME** in sequence, until the spring housing is seated against the clamp tubes. Torque the locknuts to the appropriate value. See Table 5.



Caution:

The locknuts (18) must be tightened gradually to prevent damage to the brake components.

- 4.9.11 Lubricate the seal surfaces in the cylinder with Parker O-Lube® and carefully slide the cylinder onto the spring housing. Take special care to avoid damaging the seal lips.
- 4.9.12 Attach the cylinder to the pressure plate with the screws(20), washers(17) and spacer tubes(27) removed in 4.3. Use Loctite® Locquic® Primer Grade "T" to clean and prepare the screw threads and install with Loctite® #262. Using a crosswise pattern, torque the screws to the value shown on Table 5.



Warning:

Loctite® Primer "T" contains harmful vapors. Refer to the product label for proper safety precautions

- 4.9.12 Clean and prepare the threads on the screws (21) with Loctite® Locquic® Primer Grade "T" and install with Loctite® #262, making sure the washers (18) are in place. Using a crosswise pattern, tighten the screws one turn at a time until the spacer tubes are clamped between the cylinder and pressure plate. Torque the screws to the value shown on Table 4.
- 4.9.13 Install tensioner per Section 2.0

4.10 Corrosion Protection



Caution:

All previously painted areas must be touched up after maintenance or installation to provide corrosion protection.

- 4.10.1 Clean any contamination, scale, or loose paint from disturbed surfaces.
- 4.10.2 Touch up any disturbed area with an organic zinc primer.

- 4.10.3 Paint areas with two coats of a high solid two part, marine grade epoxy paint as per manufacturers instructions.

5.0 ORDERING INFORMATION/ TECHNICAL ASSISTANCE

5.1 Equipment Reference

- 5.1.1 In any correspondence regarding Airflex equipment, refer to the information on the product nameplate.

Loctite, Locquic, Permaflex and Superflex are registered trademarks of Loctite Corporation.
Polypak and Parker O-Lube are registered trademarks of Parker Hannifin Corporation
Glid Gard is a registered trademark of The Glidden Company.
MOLUB-ALLOY is a trademark of Castrol Industrial.

6.0 PARTS LISTS

ITEM		DESCRIPTION	118WCS STD. LO-CO LINING (146309AJ)		118WCS HI-CO LINING (146309AK)	
			Part Number	Qty	Part Number	Qty
1		Mounting Flange S/A	514143-01	1	514143-01	1
	2	Mounting Flange	514012	1	514012	1
	3	Wear Plate	412953	1	412953	1
	4	Hex Hd Screw	000153x0726	80	000153x0726	80
	5	Locknut	000153x0856	80	000153x0856	80
	50	Inner Support Ring	413105-01	4	413105-01	4
	51	Outer Support Ring	413106-01	4	413106-01	4
6		Stud	308139-02	12	308139-02	12
7		Friction Disc S/A	514172	1	514142	1
	8	Friction Disc	513657	1	513680	1
	9	Friction Disc Core	514145	1	514145	1
	57	Flat Head Screw	000424X0001	48	000424X0001	48
12		Clamp Tube	308207-02	12	308207-02	12
13		Pressure Plate S/A	514143-04	1	514143-04	1
	14	Pressure Plate	514015	1	514015	1
	3	Wear Plate	412953	1	412953	1
	4	Hex Hd Screw	000153X0726	80	000153X0726	80
	5	Locknut	000153X0856	80	000153X0856	80
	50	Inner Support Ring	413105-01	4	413105-01	4
	51	Outer Support Ring	413106-01	4	413106-01	4
	54	Bushing	204114-01	12	204114-01	12
16		Spring Housing	514016	1	514016	1
17		Flat Washer	000153X0727	24	000153X1185	24
18		Locknut	000110X0070	12	000110X0070	12
19		Cylinder	514017	1	514017	1
20		Hex Hd Screw	000153X1173	12	000153X1173	12
21		Polypack Seal	000402X0021	2	000402X0021	2
22		Spring	308137	16	308137	16
23		Polypack Seal	000402X0022	2	000402X0022	2
24		Warning Decal	203627	1	203627	1
25		Name Plate	307640	1	307640	1
26		Drive screw	000153X0644	8	000153X0644	8
27		Spacer Tube	308201-01	12	308201-01	12
28		Gear	Not included.	1	Not included.	1
32		Decal Plate	307753	2	307753	2
53		Spring Retainer	415823	6	415823	6

ITEM	DESCRIPTION	218WCS STD. LO-CO LINING (N/A)		218WCS HI-CO LINING (146318AK)	
		Part Number	Qty	Part Number	Qty
1	Mounting Flange S\A			514143-01	1
2	Mounting Flange			514012	1
3	Wea r P late			412953	1
4	Hex Hd S crew			000153x0 726	80
5	Loc knut			000153x0 856	80
50	Inner S upport Ri ng			413105-01	4
51	Outer S upport Ri ng			413106-01	4
6	Stud			308139-01	12
7	Friction Disc S\A			514142	1
8	Friction Disc			513680	1
9	Friction Disc Core			514145	1
57	Flat Head S crew			000424X0 001	48
12	Clamp Tube			308207-01	12
13	Press ure P late S\A			514143-04	1
14	Press ure P late			514015	1
3	Wea r P late			412953	1
4	Hex Hd S crew			000153X0 726	80
5	Loc knut			000153X0 856	80
50	Inner S upport Ri ng			413105-01	4
51	Outer S upport Ri ng			413106-01	4
55	Bushing			204114-01	12
16	S pring Housing			514016	1
17	F late Was her			000153X 1185	24
18	Lockn ut			000110X0 070	12
19	Cyl inder			514017	1
20	Hex Hd S crew			000153X 1173	12
21	Po lypac k S eal			000402X0 021	2
22	S pring			308137	16
23	Po lypac k S eal			000402X0 022	2
24	Wa rning Deca l			203627	1
25	Name P late			307640	1
26	Drive screw			000153X0 644	8
27	S pace r Tube			308201-01	12
28	Gear			Not Included	1
29	Wea r S pace r			308201-02	12
30	React ion P late S\A			514143-02	1
31	Reacti on P late			514013	1
3	Wea r P late			412953	2
4	Hex Hd S crew			000153X0 685	80
5	Loc knut			000153X0 856	80
50	Inner S upport Ri ng			413105-01	8
51	Outer S upport Ri ng			413106-01	8
54	Bushing			204114-04	12
32	Deca ll P late			307753	2
34	Re lease S pring			308138	12
53	S pring Reta iner			415823	

This information to be provided at a later date.

ITEM		DESCRIPTION	124WCS STD. LO-CO LINING (146314AJ)		124WCS HI-CO LINING (146314AK)	
			Part Number	Qty	Part Number	Qty
1		Mounting Flange S\A	514130-01	1	514130-01	1
	2	Mounting Flange	514036	1	514036	1
	3	Wear Plate	508459	1	508459	1
	4	Hex Hd Screw	000153X0685	90	000153X0685	90
	5	Locknut	000153X0856	90	000153X0856	90
	50	Inner Support Ring	413107-01	3	413107-01	3
	51	Outer Support Ring	413108-01	5	413108-01	5
6		Stud	308160-06	12	308160-06	12
7		Friction Disc S\A	514131	2	514147	2
	8	Friction Disc	508725	2	512825	2
	9	Friction Disc Core	514140	1	514140	1
	57	Flat Head Screw	000421X0407	36	000421X0407	36
12		Clamp Tube	308206-04	12	308206-04	12
13		Pressure Plate S\A	514130-04	1	514130-04	1
	14	Pressure Plate	514037	1	514037	1
	3	Wear Plate	508459	1	508459	1
	4	Hex Hd Screw	000153X0685	90	000153X0685	90
	5	Locknut	000153X0856	90	000153X0856	90
	50	Inner Support Ring	413107-01	3	413107-01	3
	51	Outer Support Ring	413108-01	5	413108-01	5
	54	Bushing	203866-0 1	12	203866-0 1	12
16		Spring Housing	514038	1	514038	1
17		Flate Was her	000153X0 854	24	000153X0 854	24
18		Loc knut	000110X0 076	12	000110X0 076	12
19		Cyl inder	514039	1	514039	1
20		Hex Hd S crew	000153X 1177	12	000153X 1177	12
21		Polypack Seal	000402X0 023	2	000402X0 023	2
22		S pring	308163	20	308163	20
23		Polypack Seal	000402X0 024	2	000402X0 024	2
24		Wa rning Deca l	203627	1	203627	1
25		Name Plate	307640	1	307640	1
26		Drive screw	000153X0 644	8	000153X0 644	8
27		S pace r Tube	308193-01	12	308193-01	12
28		Gear	Not Included	1	Not Included	1
32		Deca ll plate	307753	12	307753	12
52		Inner S pring	308165	20	308165	20
53		S pring Reta iner	307971	10	307971	10

ITEM		DESCRIPTION	224WCS STD. LO-CO LINING (1146340AJ)		224WCS HI-CO LINING (146340AK)	
			Part Number	Qty	Part Number	Qty
1		Mounting Flange S\A	514130-01	1	514130-01	1
	2	Mounting Flange	514036	1	514036	1
	3	Wear Plate	508459	1	508459	1
	4	Hex Hd Screw	000153X0685	90	000153X0685	90
	5	Locknut	000153X0856	90	000153X0856	90
	50	Inner Support Ring	413107-01	3	413107-01	3
	51	Outer Support Ring	413108-01	5	413108-01	5
6		Stud	308160-01	12	308160-01	12
7		Friction Disc S\A	514131	2	514147	2
	8	Friction Disc	508725	2	512825	2
	9	Friction Disc Core	514140	1	514140	1
	57	Flat Head Screw	000421X0407	36	000421X0407	36
12		Clamp Tube	308206-01	12	308206-01	12
13		Pressure Plate S\A	514130-04	1	514130-04	1
	14	Pressure Plate	514037	1	514037	1
	3	Wear Plate	508459	1	508459	1
	4	Hex Hd Screw	000153X0685	90	000153X0685	90
	5	Locknut	000153X0856	90	000153X0856	90
	50	Inner Support Ring	413107-01	3	413107-01	3
	51	Outer Support Ring	413108-01	5	413108-01	5
	54	Bushing	203866-01	12	203866-01	12
16		Spring Housing	514038	1	514038	1
17		Flate Washer	000153X0854	24	000153X0854	24
18		Locknut	000110X0076	12	000110X0076	12
19		Cylinder	514039	1	514039	1
20		Hex Hd Screw	000153X1177	12	000153X1177	12
21		Polypack Seal	000402X0023	2	000402X0023	2
22		Spring	308163	20	308163	20
23		Polypack Seal	000402X0024	2	000402X0024	2
24		Warning Decal	203627	1	203627	1
25		Name Plate	307640	1	307640	1
26		Drive screw	000153X0644	8	000153X0644	8
27		Spacer Tube	308193-01	12	308193-01	12
28		Gear	Not Included	1	Not Included	1
29		Wear Spacer	308193-02	12	308193-02	12
30		Reaction Plate S\A	514130-02	1	514130-02	1
	31	Reaction Plate	514040	1	514040	1
	3	Wear Plate	508459	2	508459	2
	4	Hex Hd Screw	000153X0685	90	000153X0685	90
	5	Locknut	000153X0856	90	000153X0856	90

ITEM		DESCRIPTION	336WCS STD. LO-CO LINING		336WCS HI-CO LINING (514089)	
			Part Number	Qty	Part Number	Qty
1		Mounting Flange S\A	This information to be provided at a later date.		513284-01	1
	2	Mounting Flange			512815	1
	3	Wear Plate			414026	1
	4	Hex Hd Screw			000153X0 842	108
	5	Locknut			000153X0 844	108
	50	Inner Support Ring			414032-01	6
	51	Outer Support Ring			414033-01	9
6		Stud			307111-12	16
7		Friction Disc S\A			514128	3
	8	Friction Block			513675	16
	9	Friction Disc Core			513667	1
	57	Flat Head Screw			000421X04 07	144
12		Clamp Tube			308204-04	16
13		Pressure Plate S\A			513284-04	1
	14	Pressure Plate			512794	1
	3	Wear Plate			414026	1
	4	Hex Hd Screw			000153X0 842	108
	5	Locknut			000153X0 844	108
	50	Inner Support Ring			414032-01	6
	51	Outer Support Ring			414033-01	9
	54	Bushing			203863-04	16
16		Spring Housing			514086	1
17		Flate Washer			000153X0 850	32
18		Locknut			000110X0 075	16
19		Cylinder			512809	1
20		Hex Hd Screw			000153X 1102	16
21		Polypack Seal			000402X0 005	2
22		Outer Spring			307824	44
23		Polypack Seal			000402X0 006	2
24		Warning Decal			203627	1
25		Name Plate		307640	1	
26		Drive screw		000153X0 644	8	
27		Spacer Tube		308191-05	16	
28		Gear		Not Included	1	
29		Wear Spacer		308191-04	32	
30		Reaction Plate S\A		513284-02	2	
	31	Reaction Plate		512813	1	
	3	Wear Plate		414026	2	
	4	Hex Hd Screw		000153X0 843	108	
	5	Locknut		000153X0 844	108	
	50	Inner Support Ring		414032-01	12	
	51	Outer Support Ring		414033-01	18	
	54	Bushing		203863-03	16	
32		Decal Plate		307753	2	
34		Release Spring		307175	24	
52		Inner Spring		307823	44	
53		Spring Retainer		415635	14	

Friction Disc Kits

Model	Kit PartNumber	Included in this kit		
		Description	Part Number	Quantity
18 WCB with Standard Friction Material	107726K	Loctite [®] #242	000153x0923	1 (10ml)
		Molub-alloy [®] 412 ES	000153x1182	1
		Brass Screws	000422x0008	48
		Instruction Sheet	204130	1
		Friction Disc	513657	2
		Locknuts	000110x0070	12
18 WCB with High Coefficient Friction Material	107726L	Loctite [®] #242	000153x0923	1 (10ml)
		Molub-alloy [®] 412 ES	000153x1182	1
		Brass Screws	000422x0008	48
		Instruction Sheet	204130	1
		Friction Disc	513680	2
		Locknuts	000110x0070	12
18 WCB with Super Low Coefficient Friction Material	107726M	Loctite [®] #242	000153x0923	1 (10ml)
		Molub-alloy [®] 412 ES	000153x1182	1
		Brass Screws	000422x0008	48
		Instruction Sheet	204130	1
		Friction Disc	Call Airflex	2
		Locknuts	000110x0070	12
24 WCB with Standard Friction Material	107727K	Loctite [®] #262	000153x1016	1 (.34oz)
		Molub-alloy [®] 412 ES	000153x1182	1
		Brass Screws	000421x0407	36
		Instruction Sheet	204130	1
		Friction Disc	508725	2
		Locknuts	000110x0073	12
24 WCB with High Coefficient Friction Material	107727L	Loctite [®] #262	000153x1016	1 (.34oz)
		Molub-alloy [®] 412 ES	000153x1182	1
		Brass Screws	000421x0407	36
		Instruction Sheet	204130	1
		Friction Disc	512825	2
		Locknuts	000110x0073	12
24 WCB with Super Low Coefficient Friction Material	107727M	Loctite [®] #262	000153x1016	1 (.34oz)
		Molub-alloy [®] 412 ES	000153x1182	1
		Brass Screws	000421x0407	36
		Instruction Sheet	204130	1
		Friction Disc	Call Airflex	2
		Locknuts	000110x0073	12

Friction Disc Kits Continued

Model	Kit Part Number	Included in this kit		
		Description	Part Number	Quantity
36 WCB with Standard Friction Material	107822K	Loctite [®] #262	000153x1168	1 (1.7oz)
		Molub-alloy [®] 412ES	000153x1182	1
		Brass screw	000421x0407	144
		Instruction Sheet	204130	1
		Friction Blocks		16
		Locknuts	512809	16
36 WCB with High Coeffi- cient Friction Material	107822L	Loctite [®] #262	000153x1168	1 (1.7oz)
		Molub-alloy [®] 412ES	000153x1182	1
		Brass screw	000421x0407	144
		Instruction Sheet	204130	1
		Friction Blocks	513675	16
		Locknuts	512809	16
36 WCB with Super Low Coefficient Friction Material	107822M	Loctite [®] #262	000153x1168	1 (1.7oz)
		Molub-alloy [®] 412ES	000153x1182	1
		Brass screw	000421x0407	144
		Instruction Sheet	204130	1
		Friction Blocks	Call Airflex	16
		Locknuts	512809	16

Products we offer:

- Cartridge valves
- DCV directional control valves
- Electric converters
- Electric machines
- Electric motors
- Gear motors
- Gear pumps
- Hydraulic integrated circuits (HICs)
- Hydrostatic motors
- Hydrostatic pumps
- Orbital motors
- PLUS+1® controllers
- PLUS+1® displays
- PLUS+1® joysticks and pedals
- PLUS+1® operator interfaces
- PLUS+1® sensors
- PLUS+1® software
- PLUS+1® software services, support and training
- Position controls and sensors
- PVG proportional valves
- Steering components and systems
- Telematics

Danfoss Power Solutions is a global manufacturer and supplier of high-quality hydraulic and electric components. We specialize in providing state-of-the-art technology and solutions that excel in the harsh operating conditions of the mobile off-highway market as well as the marine sector. Building on our extensive applications expertise, we work closely with you to ensure exceptional performance for a broad range of applications. We help you and other customers around the world speed up system development, reduce costs and bring vehicles and vessels to market faster.

Danfoss Power Solutions – your strongest partner in mobile hydraulics and mobile electrification.

Go to www.danfoss.com for further product information.

We offer you expert worldwide support for ensuring the best possible solutions for outstanding performance. And with an extensive network of Global Service Partners, we also provide you with comprehensive global service for all of our components.

Local address:

Hydro-Gear

www.hydro-gear.com

Daikin-Sauer-Danfoss

www.daikin-sauer-danfoss.com

Danfoss
Power Solutions (US) Company
 2800 East 13th Street
 Ames, IA 50010, USA
 Phone: +1 515 239 6000

Danfoss
Power Solutions GmbH & Co. OHG
 Krokamp 35
 D-24539 Neumünster, Germany
 Phone: +49 4321 871 0

Danfoss
Power Solutions ApS
 Nordborgvej 81
 DK-6430 Nordborg, Denmark
 Phone: +45 7488 2222

Danfoss
Power Solutions Trading
(Shanghai) Co., Ltd.
 Building #22, No. 1000 Jin Hai Rd
 Jin Qiao, Pudong New District
 Shanghai, China 201206
 Phone: +86 21 2080 6201