

Airflex[®]
Clutches and Brakes



Airflex[®] Constricting type
Clutches and Brakes
Catalog

Section B

Airflex® Constricting Type

Clutches and Brakes

Section B

Constricting Features	17
Element Descriptions	19
CB Construction	21
Technical and Dimensional Data	26
Clutch and Brake Applications	32
Mounting Components	61
VC Elements	62
Technical and Dimensional	73
Clutch and Brake Applications	74
Mounting Components	98
CM Elements	106
Selection Procedure	110

Airflex® Constricting Features

Section B

How They Work

CB, CM and VC elements utilize a rugged tire-like neoprene and cord tube that expands radially inward when pressurized. The constricting tube forces friction shoes against an outer cylindrical drum surface. The rate at which the tube is pressurized determines the rate at which element torque increases. Final tube pressure determines the element torque capacity.

Design Features

Plate Clutch

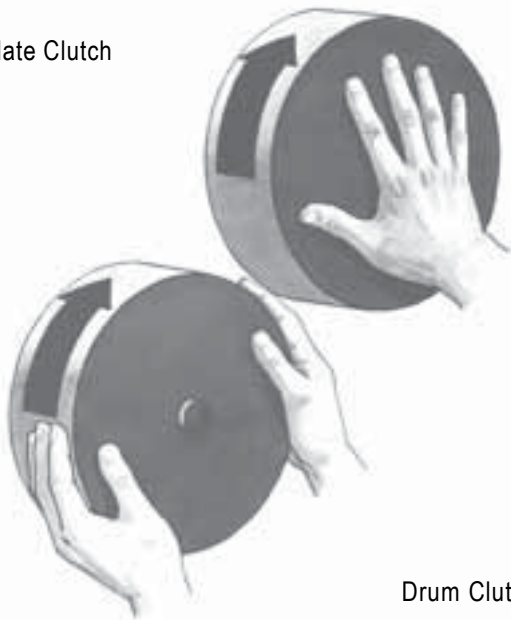

Drum Clutch

- **Uniform contact velocity**

Friction shoe contact occurs across the cylindrical surface of the drum where the contact velocity is constant unlike plate types where the contact velocity varies across the friction plate face.

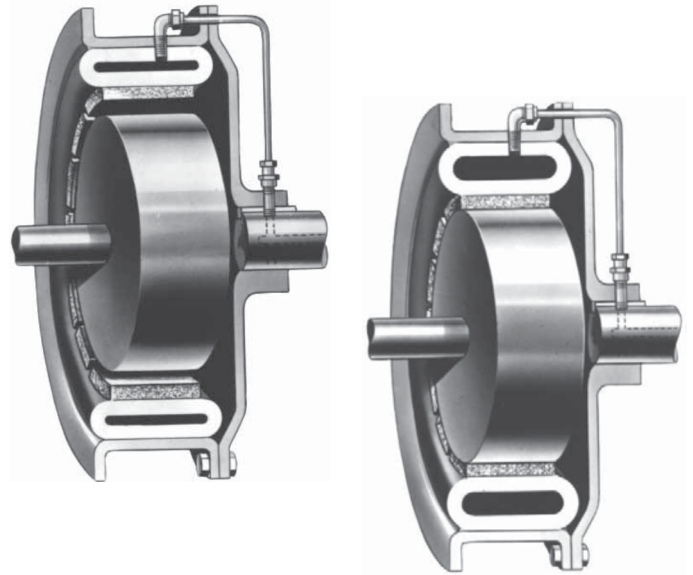

- **Force applied at maximum radius from axis**

Airflex constricting elements concentrate the frictional force on the outside drum diameter thereby achieving maximum torque. The torque lever arm is the drum radius, not a reduced radius as occurs in plate clutches. Not only is the force generated at the optimum radius, it is also applied Uniformly around the drum circumference.

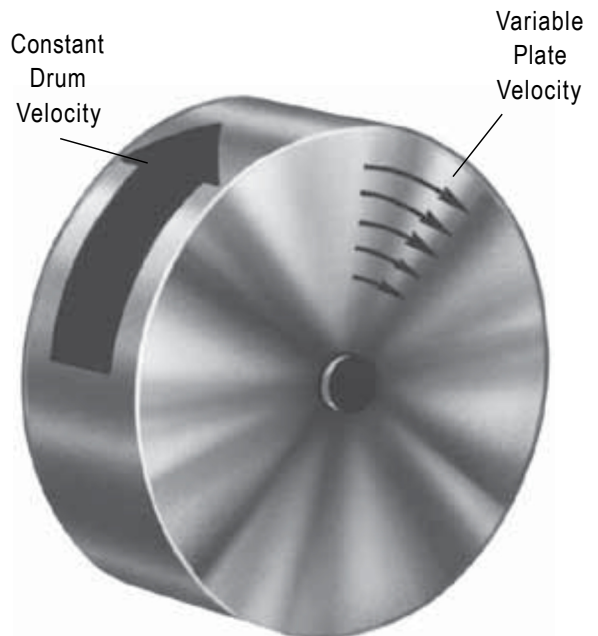

Airflex® Constricting Features

Section B

- **Self-adjustment**

As friction surfaces wear, the tube constricts further and compensates for the wear. Normal wear will not reduce torque capacity.

- **No lubrication**

There are no close fitting sliding components which require lubrication.

- **Centrifugal force assists clutch disengagement**

Upon release of tube pressure, centrifugal force, acting on the friction shoes at the rotating element, helps retract the shoes away from the drum surface. The centrifugal effect expels the tube pressurizing media and minimizes the possibility of disengaged friction shoe drag.

- **Operates in any plane**

The constricting design combined with centrifugal effects permits clutch operation in any plane. A plate clutch operates best in a vertical plane.

- **Gap mounting**

The constricting drum design allows a gap between the ends of the driving and driven shafts. This gap provides a space through which the element and drum can be removed to permit shaft alignment, clutch maintenance without disturbing existing shaft alignment and the removal of driving or driven components.

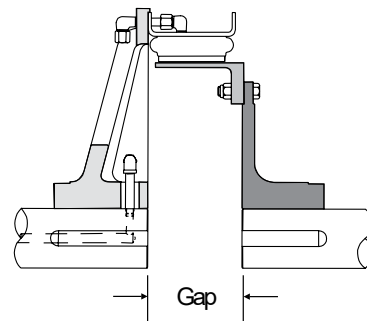
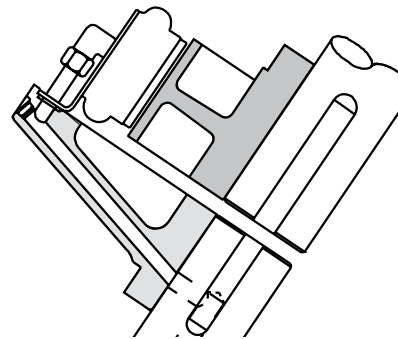
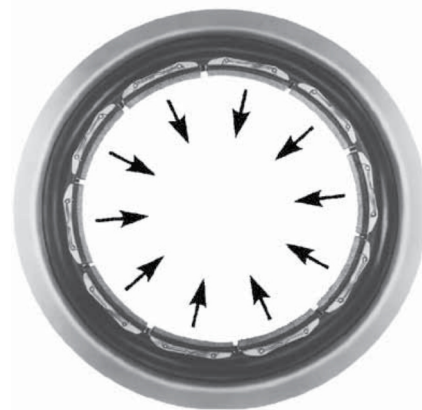

Airflex® Element Descriptions

Section B

Elements are described by the number and type of fitting used to make the connection from the tube valve to the rim flange, the type of friction material and any special rim features. Since most of the special rim features pertain to CB elements only, the CB cross section has been used in the illustrations. A glossary of commonly used descriptive terms with their abbreviations in parenthesis follow:

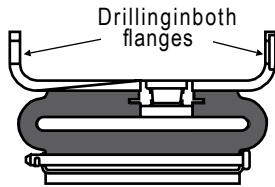

Dual drilled (DD) - Both flanges of the rim are drilled for air and/or mounting connections. Required for one of the elements used in a dual element and for air bridge mounting.

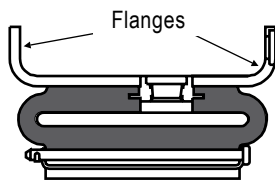

Dual flange (DFL) - A CB description for rims with two flanges. Standard on element sizes 16CB500 thru 45CB525. This description used primarily to differentiate between the single and dual flanged 12CB and 14CB elements.

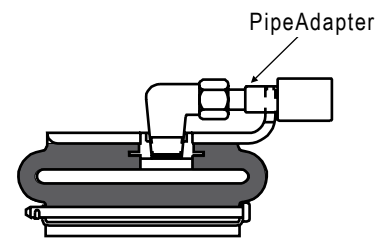

Pipe adapter - An adapter to connect standard tube fittings to pipe fittings.

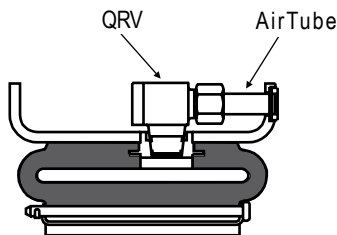

Quick release valve (QRV) - The plumbing from the valve to the rim flange incorporating a quick release valve and air tube.

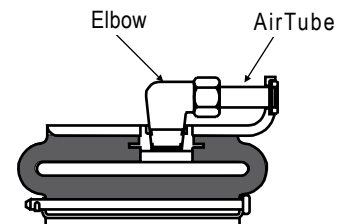

Side connection (SC) - The plumbing from the valve to the rim flange incorporating an elbow and air tube.

Airflex® Element Descriptions

Section B

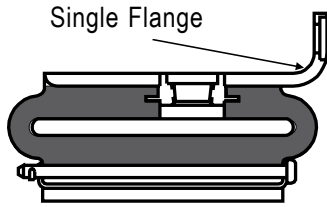

Single flange (SGL FL) - A CB description for rims having one flange. Element sizes 3CB150 thru 10CB300 have one flange. Element sizes 12CB350 and 14CB400 can be furnished single or dual flanged.

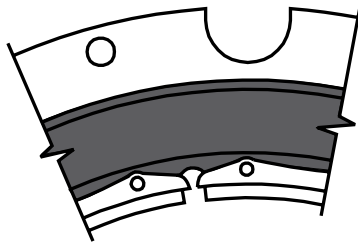

Slotted rim (SLOT) - A U-shaped cutout in the rim flange providing clearance for piping directly to the valve. Used with pipe adapter and in the small CB clutch applications which incorporate tapered bushings.

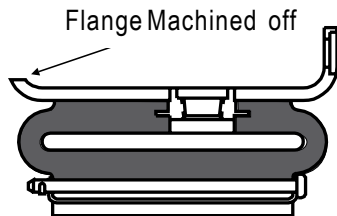

Turned down flange (TDF) - Applies to CB elements only. Element sizes 16CB500 thru 45CB525 have dual flange rims. This description is used when one flange is removed or “turned down” to provide clearance for adjacent components. Used primarily in FSPA applications.

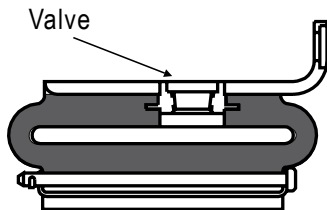

Valve (VA or VAL or VL) - That part of the tube which permits a mechanical connection and through which the activating media enter and exhausts. Element sizes 3CB150 thru 14CB400 and 11.5VC500 can be furnished with either one or two valves; larger sizes with either one, two or four valves.

Lining (LNG or LN) or Friction lining (FR LNG) - Elements can be furnished with linings having different coefficients of friction. When no mention is made in the element description, standard linings are furnished. The lining descriptions are:

- **Standard lining** - This lining will produce the published element torque ratings.
- **Low coefficient (LO-CO) or Slip lining** - Lining that has a lower coefficient of friction than the standard lining. Used primarily for continuous slip or tensioning applications.

- **High coefficient (HI-CO) or Cork lining** - Lining that has a higher coefficient of friction than the standard lining. Used primarily in applications in which the elements operate in the engaged or locked up position for extended periods of time.
- **High coefficient with drive bar** - Lining that has a higher coefficient of friction than standard but is used in similar applications to standard.



Single Flange Element



Dual Flange Element

The type CB element assembly is designed and built to provide dependable clutch or brake service in the most exacting industrial applications. It is suited to high speed, cyclic operations, as well as for coupling and general power transmission.

CB design, construction and operation is quite simple. A neoprene rubber tube reinforced with several plies of cord is bonded on its outside diameter to a steel rim. Friction shoes are attached to the tube's inside diameter by pins which in turn are held in position by lock wires, except for sizes 3CB150 through 5CB200 which have friction material bonded to the rubber tube. Pressurizing the tube forces the friction shoes to engage around a cylindrical drum.

Element torque capacity is dependent upon the applied pressure and rotating speed. Catalog ratings are given at 75 psi (5.2 bar) and zero rpm. Maximum recommended pressure is 110 psi (7.6 bar). Adjustment for speed is explained under Selection Procedure.

CB elements are available in 20 sizes which are identified by the drum diameter in inches on which they constrict and the width in inches of its friction lining. For instance, size 16CB500 is designed to constrict on a 16 inch diameter drum

and has a friction lining width of 5 inches. The smallest CB element will constrict on a 3 inch (76mm) diameter drum and the largest on a 45 inch (1143mm) diameter drum.

Element sizes 3CB150 through 10CB300 have rims with one flange. Element sizes 12CB350 and 14CB400 are normally furnished with rims having one flange; however, they can also be furnished, when specified, with two flanges. Element sizes 16CB500 and larger have rims with two flanges. CB elements are grouped and described as being single flanged or dual flanged elements.

Two dual flanged elements can be bolted together to form a dual element having twice the torque capacity of a single element. Dual elements can be furnished in sizes 12CB350 through 45CB525.

Because the rubber tube is the connecting member between the driving and driven shafts, the CB design offers the following features in addition to the constricting features described earlier in this section.

Airflex®CB Features

Section B

One moving component

The tube is the only moving component. There are no springs or sliding parts.

Cushioned action

The tube transmits the torque through its side walls, cushioning damaging shock loads thereby protecting drive components. The rubber tube construction dampens the effects of torsional vibrations.

Flexible coupling

The tube flexibility is able to compensate for minor shaft misalignment and axial movement.

Split Elements

Element sizes 6CB200 and up are available in a split configuration. They are used in applications where there is limited axial space for maintenance or where the drum is mounted between bearings and the shaft cannot be moved for maintenance. Sizes through the 10CB300 can only be used as brakes. Larger sizes can also be used in relatively low-speed clutch applications. Note that split tubes are not as durable as standard continuous tube. The following pages give additional descriptive information, selection procedures and common clutch and brake arrangements for the complete CB product line.

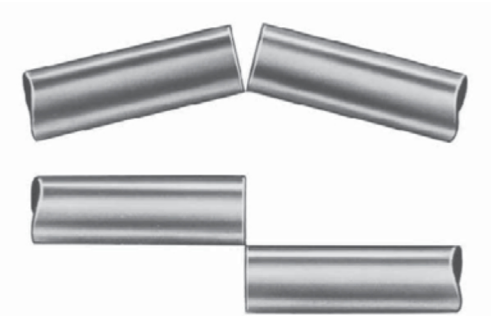

Size	Torque Rating	
	lb · in @ 75 psi	N · m @ 5,2 bar
3CB150	360	41
4CB200	1,000	113
5CB200	1,460	165
6CB200	2,040	231
8CB250	4,290	485
10CB300	8,150	921
12CB350	13,300	1500
14CB400	19,700	2230
16CB500	35,200	3980
18CB500	44,000	4970
20CB500	53,600	6060
22CB500	62,300	7040
24CB500	75,000	8480
26CB525	92,400	10400
28CB525	106,000	12000
30CB525	121,000	13700
32CB525	137,000	15500
36CB525	172,000	19400
40CB525	211,000	23800
45CB525	260,000	29400

Where Used:

- **Can Making Machinery**
- **Commercial Laundry Equipment**
- **Metal Forming Machinery**
- **Oil Field Machinery**
- **Printing Machinery**
- **Rubber Processing Machinery**
- **Tire Building Machinery**

Airflex®CB Component Descriptions

Section B

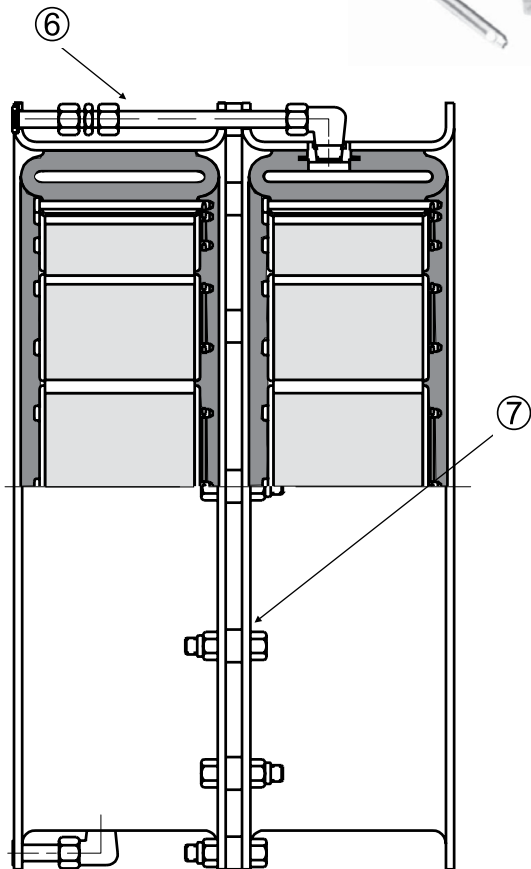
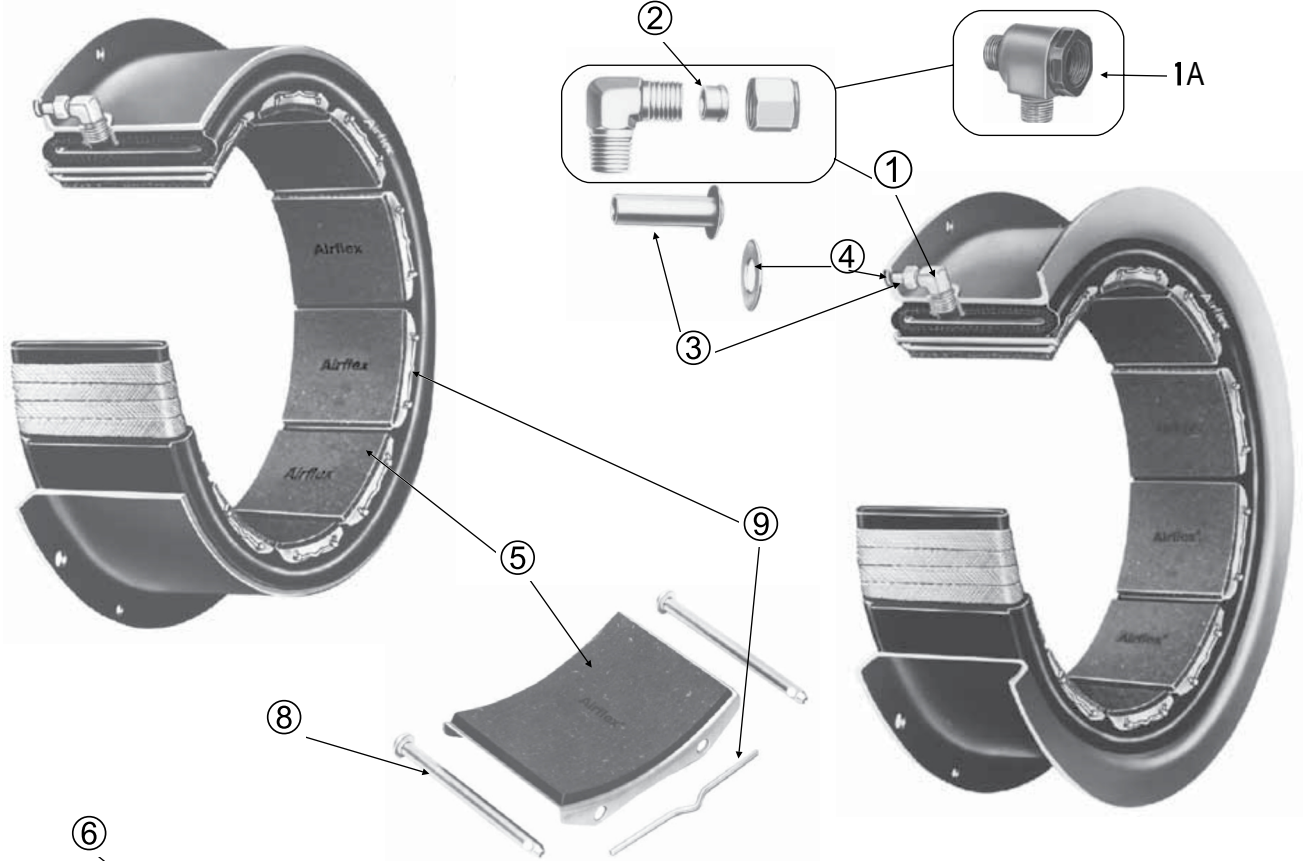

Item	Component Description
1	Elbow Assembly
1A ❶	Optional -Quick Release Valve Assembly
1B ❶	Optional -Quick Release Valve Muffler
2	Compression Ring
3	Air Connection Tube
4	Air Connection Gasket
5 ❷	Friction Shoe Assembly
6	Air Tube Group (Dual Mounted)
7	Spacer Group (Dual Mounted)
8 ❷	Shoe Pin
9 ❷	Lockwire
5, 8 & 9	Friction Shoe Replacement Kit

Notes:

- ❶ This option not available for sizes 3 thru 14.
- ❷ These items are not applicable to sizes 3 thru The friction material is bonded to the rubber tube and is not replaceable.

Airflex®CB Element Part Numbers

Section B

A double alpha suffix is added to the basic element part number to completely describe the element configuration.

The basic element part number is shown on the element catalog pages. Alphas for the more common element configurations are shown on this page. The element part number used in the above example identifies a 16CB500 element equipped with standard friction linings and one side connection.

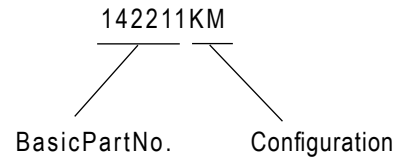

Alpha Suffixes for 3 thru 14 CB Elements

No. of Valves, Side Connections, or QRV's	Type of Lining	Special Rim Features	Alpha Suffixes	
			Valves only	With Side Connections
1	Standard		JA	JB
1	Standard	Slotted	JC	
1	Cork ①		JT	JN
1	Cork ①	Slotted	JU	
2	Standard		JH	JG
2	Standard	Slotted	JK	
2	Cork ①			JQ

Airflex®CB Element Part Numbers

Section B

Alpha Suffixes for 16 thru 45 CB Elements

No. of Valves, Side Connections, or QRV's	Type of Lining	Special Rim Features	Alpha Suffixes		
			Valves only	with Side Connections	with QRV's
1	Standard		KY	KM	KN
1	Standard	Dual Drilled	KS	LH	LJ
1	Cork		LQ	MG	LA
1	Cork	Dual Drilled	LR		
2	Standard		LX	LB	LK
2	Standard	Dual Drilled	MT		LW
2	Cork		KD	KE	
2	Cork	Dual Drilled	LY	KL	
4	Standard		KZ	KP	KR
4	Standard	Dual Drilled	LS	KT	KU
4	Cork		NR	LV	ML
4	Cork	Dual Drilled	LT	LU	NE

Alpha Suffixes for Dual 12 thru 45 CB Elements

②

No. of Side Connections or QRV's	Type of Lining	Alpha Suffixes	
		with Side Connections	with QRV's
2	Standard	DA	DD
2	Cork	DF	DJ
4	Standard	DK	DL
4	Cork	DT	

Notes:

- ① Not available for sizes 3 thru 5.
- ② Dual sizes 12 and 14 elements only available with suffixes DA and DF.

Airflex® Single CBElements

Form CB-401 Technical Data — Sizes 3 to 14

Section B

English		lb · in @75psi	rpm	psi/rpm ²	lb · ft ²	lb	in ²	inches		in ³	inches
3CB150	142252	360	2000	1.5 E-06	0.1	1.8	14	0.20	0.04	7	2.90
4CB200	142840	1000	2000	1.7 E-06	0.2	2.5	23	0.12	0.03	10	3.90
5CB200	142253	1460	2000	2.0 E-06	0.4	3.5	30	0.20	0.04	17	4.90
6CB200	142095	2040	1800	6.0 E-06	1.0	7.0	36	0.14	0.06	19	5.90
8CB250	142096	4290	1800	7.0 E-06	2.0	9.0	61	0.12	0.06	30	7.90
10CB300	142197	8150	1800	10.0 E-06	6.0	19.0	91	0.20	0.06	50	9.90
12CB350	142098	13300	1800	12.0 E-06	11.0	26.0	128	0.20	0.06	80	11.90
14CB400	142087	19700	1800	15.0 E-06	17.0	31.0	170	0.20	0.06	70	13.90

Size	① Part Number	② M, Torque Rating	③ Maximum Speed	④ Centrifugal Loss Constant	Wk ² J	Weight Mass	Friction Area	Friction Lining Thickness		⑥ AirTube Cavity	Minimum Drum Diameter
								New	Worn		
3CB150	142252	40,7	2000	0,10 E-06	0,00	0,8	90,3	5	1	0,12	74
4CB200	142840	113	2000	0,12 E-06	0,01	1,1	148,4	3	1	0,17	99
5CB200	142253	165	2000	0,14 E-06	0,02	1,6	193,5	5	1	0,28	124
6CB200	142095	231	1800	0,41 E-06	0,04	3,2	232,2	4	2	0,32	150
8CB250	142096	485	1800	0,48 E-06	0,08	4,1	393,5	3	2	0,49	201
10CB300	142197	921	1800	0,69 E-06	0,25	8,6	587,0	5	2	0,82	251
12CB350	142098	1500	1800	0,83 E-06	0,46	12	825,6	5	2	1,31	302
14CB400	142087	2230	1800	1,04 E-06	0,71	14	1096,5	5	2	1,15	353

SI		N · m @ 5,2bar	rpm	bar/rpm ²	kg · m ²	kg	cm ²	millimeters		dm ³	millimeters
----	--	-------------------	-----	----------------------	---------------------	----	-----------------	-------------	--	-----------------	-------------

Notes:

- ① Refers to basic part number only. When ordering, the number of air inlets and type of connection must be specified.
- ② Dynamic torque shown, static torque approximately 25% greater. Torque in each application is dependent upon air pressure and speed.
- ③ Tolerance for sizes:
3 thru 5
+0.000/-0.003 in (+0,00/-0,08 mm)
6 and larger
+0.000/-0.005 in (+0,00/-0,13 mm)
- ④ American National Pipe Thread. Sizes 3 thru 5 only available with one air inlet. All other sizes available with either one or two air inlets.
- ⑤ Maximum rpm is dependent upon operating conditions and varies for each application. Consult factory for applications exceeding these speeds.
- ⑥ Drum contact with worn shoes.

Airflex® Single CBElements

Form CB-401 Dimensional Data — Sizes 3 to 14
Section B

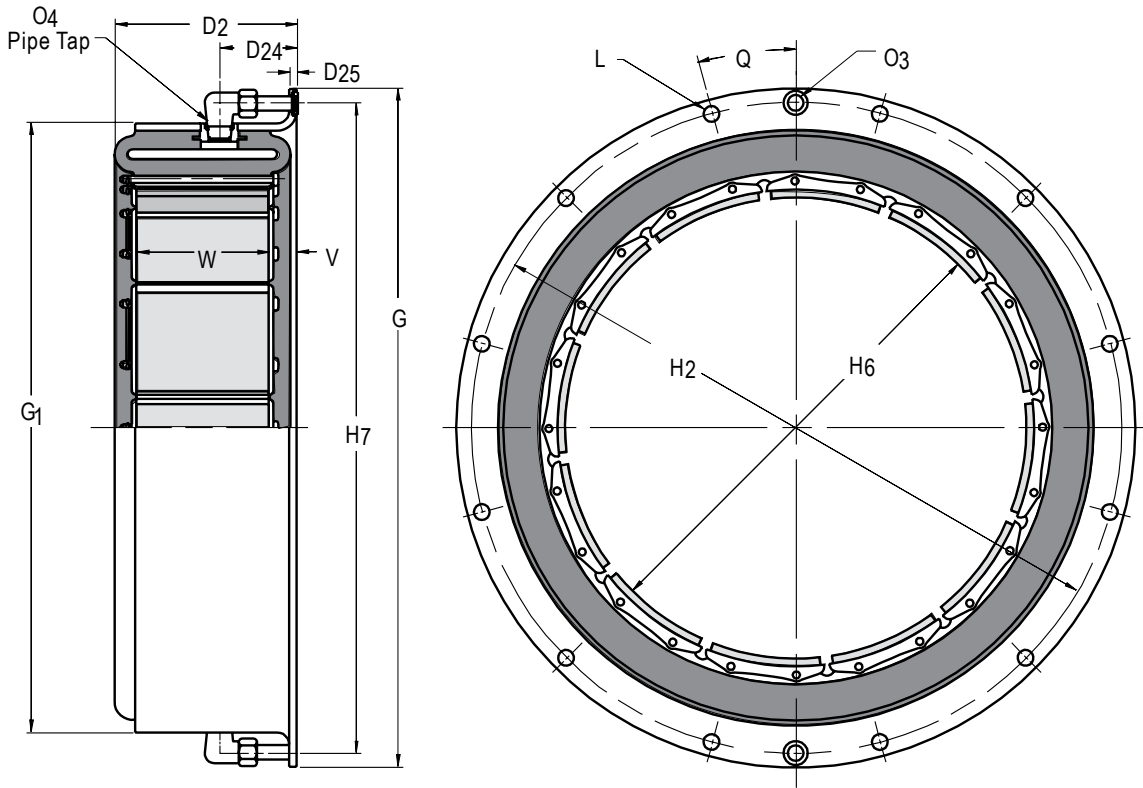

English		lb · in @75psi	Dimensions in inches															
3CB150	142252	360	2.16	1.18	0.10	6.299	4.86	5.748	3.15	5.75	8	0.25	0.28	1/8-27	22.500	0.35	6	1.50
4CB200	142840	1000	2.63	1.38	0.09	7.248	5.81	6.688	4.13	6.69	8	0.25	0.19	1/8-27	22.500	0.38	6	2.00
5CB200	142253	1460	2.85	1.50	0.10	8.819	7.20	8.071	5.16	8.07	8	0.31	0.29	1/8-27	22.500	0.48	6	2.00
6CB200	142095	2040	2.94	1.56	0.09	10.752	9.06	10.000	6.16	10.00	8	0.38	0.31	3/8-18	22.500	0.56	6	2.00
8CB250	142096	4290	3.44	1.91	0.09	12.875	11.19	12.125	8.16	12.13	8	0.38	0.31	3/8-18	22.500	0.56	8	2.50
10CB300	142197	8150	4.13	2.00	0.19	15.373	13.63	14.625	10.13	14.63	12	0.38	0.31	3/8-18	15.000	0.69	10	3.00
12CB350	142098	13300	4.72	2.00	0.19	17.625	15.88	16.875	12.13	16.88	14	0.38	0.31	3/8-18	12.857	0.69	12	3.50
14CB400	142087	19700	5.22	2.00	0.19	19.625	17.88	18.875	14.13	18.88	16	0.38	0.31	3/8-18	11.250	0.69	14	4.00

Size	Part Number	Ø M _t Torque Rating	D ₂	D ₂₄	D ₂₅	Ø G	G ₁	H ₂	H ₆	H ₇	L (Bolt)		O ₃	Ø O ₄	Q (Deg)	V	W	
											No.	Size	No		Width			
3CB150	142252	40,7	55	30	2	160,0	123	146,0	80	146	8	6	7	1/8-27	22,500	9	6	38
4CB200	142840	113	67	35	2	184,1	148	169,9	105	170	8	6	5	1/8-27	22,500	10	6	51
5CB200	142253	165	72	38	2	224,0	183	205,0	131	205	8	8	7	1/8-27	22,500	12	6	51
6CB200	142095	231	75	40	2	273,1	230	254,0	156	254	8	10	8	3/8-18	22,500	14	6	51
8CB250	142096	485	87	48	2	327,0	284	308,0	207	308	8	10	8	3/8-18	22,500	14	8	64
10CB300	142197	921	105	51	5	390,5	346	371,5	257	371	12	10	8	3/8-18	15,000	17	10	76
12CB350	142098	1500	120	51	5	447,7	403	428,6	308	429	14	10	8	3/8-18	12,857	17	12	89
14CB400	142087	2230	133	51	5	498,5	454	479,4	359	479	16	10	8	3/8-18	11,250	17	14	102

SI **N · m @ 5,2bar** Dimensions in millimeters

Airflex® Single CBElements

Form CB-402 Technical Data — Sizes 12 to 45

Section B

English		lb · in @75psi	rpm	psi/rpm ²	lb · ft ²	lb	in ²	inches		in ³	inches
12CB350	142098	13000	1800	12 E-06	12	30	128	0.20	0.06	80	11.90
14CB400	142087	19700	1800	15 E-06	21	35	170	0.20	0.06	70	13.90
16CB500	142211	35200	1550	20 E-06	52	74	241	0.26	0.06	140	15.87
18CB500	142264	44000	1400	23 E-06	70	81	262	0.26	0.06	160	17.87
20CB500	142265	53600	1300	25 E-06	90	88	288	0.26	0.06	170	19.87
22CB500	142266	62300	1250	28 E-06	114	95	312	0.26	0.06	190	21.87
24CB500	142267	75000	1200	30 E-06	142	102	338	0.26	0.06	200	23.87
26CB525	142268	92400	1100	34 E-06	210	133	404	0.33	0.06	260	25.81
28CB525	142269	106000	1000	37 E-06	252	140	430	0.33	0.06	280	27.81
30CB525	142270	121000	950	40 E-06	303	148	458	0.33	0.06	290	29.81
32CB525	142271	137000	900	43 E-06	359	157	483	0.33	0.06	310	31.81
36CB525	142272	172000	800	48 E-06	510	178	550	0.33	0.06	350	35.81
40CB525	142273	211000	750	52 E-06	730	201	610	0.33	0.06	380	39.81
45CB525	142081	260000	670	64 E-06	1115	262	675	0.33	0.06	430	44.75

Size	Part Number	M. Torque Rating	Maximum Speed	C. Centrifugal Loss Constant	Wk ²	Weight	Friction Area	Friction Lining Thickness		AirTube Cavity	Minimum Drum Diameter
					J	Mass		New	Worn		
12CB350	142098	1470	1800	0,83 E-06	0,50	14	826	5	2	1,31	302
14CB400	142087	2230	1800	1,04 E-06	0,88	16	1097	5	2	1,15	353
16CB500	142211	3980	1550	1,38 E-06	2,18	34	1554	7	2	2,30	403
18CB500	142264	4970	1400	1,59 E-06	2,94	37	1690	7	2	2,62	454
20CB500	142265	6060	1300	1,73 E-06	3,78	40	1858	7	2	2,79	505
22CB500	142266	7040	1250	1,93 E-06	4,79	43	2012	7	2	3,12	555
24CB500	142267	8480	1200	2,07 E-06	5,96	46	2180	7	2	3,28	606
26CB525	142268	10400	1100	2,35 E-06	8,82	60	2606	8	2	4,26	656
28CB525	142269	12000	1000	2,55 E-06	10,58	63	2774	8	2	4,59	706
30CB525	142270	13700	950	2,76 E-06	12,73	67	2954	8	2	4,76	757
32CB525	142271	15500	900	2,97 E-06	15,08	71	3115	8	2	5,08	808
36CB525	142272	19400	800	3,31 E-06	21,42	81	3548	8	2	5,74	910
40CB525	142273	23800	750	3,59 E-06	30,66	91	3935	8	2	6,23	1011
45CB525	142081	29400	670	4,42 E-06	46,83	119	4354	8	2	7,05	1137

SI		N · m @ 5,2bar	rpm	bar/rpm ²	kg · m ²	kg	cm ²	millimeters		dm ³	millimeters
----	--	-------------------	-----	----------------------	---------------------	----	-----------------	-------------	--	-----------------	-------------

Notes:

- ① Refers to basic part number only. When ordering, the number of air inlets and type of connection must be specified.
- ② Dynamic torque shown, static torque approximately 25% greater. Torque in each application is dependent upon air pressure and speed.
- ③ Tolerance for sizes:
12 thru 24, 28 and 32
+0.000/-0.005 in (+0,00/-0,13 mm)
26 and 30
+0.000/-0.008 in (+0,00/-0,20 mm)
36 thru 45
+0.000/-0.010 in (+0,00/-0,25 mm)
- ④ American National Pipe Thread.
Sizes 12 and 14 available with one or two air inlets. All other sizes available with one, two or four air inlets.
- ⑤ 10.00 degrees for elements with one air inlet, 5.00 degrees for elements with two or four air inlets.
- ⑥ Maximum rpm is dependent upon operating conditions and varies for each application. Consult factory for applications exceeding these speeds.
- ⑦ Drum contact with worn shoes.

Airflex® Single CBElements

Form CB-402 Dimensional Data — Sizes 12 to 45

Section B

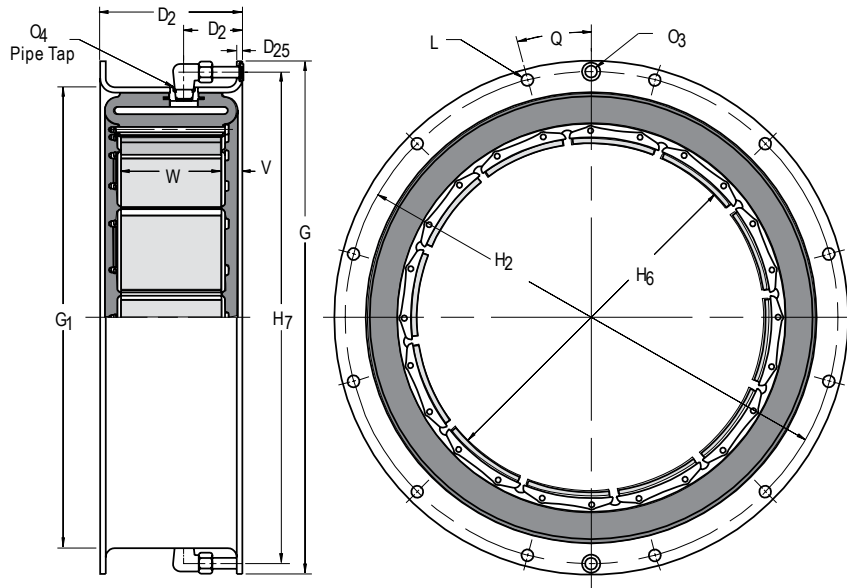

English		lb · in @75psi		Dimensions in inches														
12CB350	142098	13300	4.88	2.00	0.19	17.625	15.88	16.875	12.13	16.88	14	0.375	0.31	3/8-18	12.857	0.69	12	3.50
14CB400	142087	19700	5.38	2.00	0.19	19.625	17.88	18.875	14.13	18.88	16	0.375	0.31	3/8-18	11.250	0.69	14	4.00
16CB500	142211	35200	6.63	2.50	0.19	23.500	20.75	22.500	16.19	22.25	8	0.500	0.38	3/8-18	22.500	0.81	10	5.00
18CB500	142264	44000	6.63	2.50	0.19	25.500	22.75	24.375	18.19	24.38	12	0.500	0.38	3/8-18	15.000	0.81	11	5.00
20CB500	142265	53600	6.63	2.50	0.19	27.500	24.75	26.375	20.19	26.38	12	0.500	0.38	3/8-18	15.000	0.81	12	5.00
22CB500	142266	62300	6.63	2.50	0.19	29.500	26.75	28.375	22.19	28.38	12	0.500	0.38	3/8-18	15.000	0.81	13	5.00
24CB500	142267	75000	6.63	2.50	0.19	31.500	28.75	30.375	24.19	30.38	16	0.500	0.38	3/8-18	11.250	0.81	14	5.00
26CB525	142268	92400	6.94	2.50	0.25	34.000	31.00	32.750	26.19	32.50	16	0.625	0.50	1/2-14	11.250	0.84	16	5.25
28CB525	142269	106000	6.94	2.50	0.25	36.000	33.00	34.750	28.19	34.50	16	0.625	0.50	1/2-14	11.250	0.84	17	5.25
30CB525	142270	121000	6.94	2.50	0.25	38.000	35.00	36.750	30.19	36.50	16	0.625	0.50	1/2-14	11.250	0.84	18	5.25
32CB525	142271	137000	6.94	2.50	0.25	40.000	37.00	38.750	32.19	38.50	18	0.625	0.50	1/2-14	⊕	0.84	19	5.25
36CB525	142272	172000	6.94	2.75	0.28	44.625	41.56	43.125	36.19	43.25	18	0.750	0.63	3/4-14	⊕	0.84	22	5.25
40CB525	142273	211000	6.94	2.75	0.28	48.625	45.56	47.125	40.19	47.25	20	0.750	0.63	3/4-14	9.000	0.84	24	5.25
45CB525	142081	260000	6.94	2.75	0.28	53.625	50.69	52.125	45.19	52.25	24	0.750	0.63	3/4-14	7.500	0.84	27	5.25

Size	Part Number	M _r Torque Rating	D ₂	D ₂₄	D ₂₅	G	G ₁	H ₂	H ₆	H ₇	L (Bolt)		O ₃	O ₄	Q (Deg)	V	W	
											No.	Size					No	Width
12CB350	142098	1500	124	51	5	447,7	403	428,6	308	429	14	10	8	3/8-18	12,857	17	12	89
14CB400	142087	2230	137	51	5	498,5	454	479,4	359	479	16	10	8	3/8-18	11,250	17	14	102
16CB500	142211	3980	168	64	5	596,9	527	571,5	411	565	8	13	10	3/8-18	22,500	21	10	127
18CB500	142264	4970	168	64	5	647,7	578	619,1	462	619	12	13	10	3/8-18	15,000	21	11	127
20CB500	142265	6060	168	64	5	698,5	629	669,9	513	670	12	13	10	3/8-18	15,000	21	12	127
22CB500	142266	7040	168	64	5	749,3	679	720,7	564	721	12	13	10	3/8-18	15,000	21	13	127
24CB500	142267	8480	168	64	5	800,1	730	771,5	614	772	16	13	10	3/8-18	11,250	21	14	127
26CB525	142268	10400	176	64	6	863,6	787	831,9	665	826	16	16	13	1/2-14	11,250	21	16	133
28CB525	142269	12000	176	64	6	914,4	838	882,7	716	876	16	16	13	1/2-14	11,250	21	17	133
30CB525	142270	13700	176	64	6	965,2	889	933,5	767	927	16	16	13	1/2-14	11,250	21	18	133
32CB525	142271	15500	176	64	6	1016,0	940	984,3	818	978	18	16	13	1/2-14	⊕	21	19	133
36CB525	142272	19400	176	70	7	1133,5	1056	1095,4	919	1099	18	19	16	3/4-14	⊕	21	22	133
40CB525	142273	23800	176	70	7	1235,1	1157	1197,0	1021	1200	20	19	16	3/4-14	9,000	21	24	133
45CB525	142081	29400	176	70	7	1362,1	1287	1324,0	1148	1327	24	19	16	3/4-14	7,500	21	27	133

SI N · m @ 5,2bar Dimensions in millimeters

Airflex® Dual CBElements

Form CB-403 Technical Data — Sizes 12 to 45

Section B

English		lb · in @75psi	rpm	psi/rpm ²	lb · ft ²	lb	in ²	inches		in ³	inches
12CB350	142731	26600	1800	12 E-06	25	62	256	0.20	0.06	160	11.90
14CB400	142604	39400	1800	15 E-06	42	75	340	0.20	0.06	140	13.90
16CB500	142432	70400	1550	20 E-06	106	151	482	0.26	0.06	280	15.87
18CB500	142433	88000	1400	23 E-06	144	166	524	0.26	0.06	320	17.87
20CB500	142434	107200	1300	25 E-06	185	180	576	0.26	0.06	340	19.87
22CB500	142435	124600	1250	28 E-06	233	194	624	0.26	0.06	380	21.87
24CB500	142436	150000	1200	30 E-06	292	209	676	0.26	0.06	400	23.87
26CB525	142437	184800	1050	34 E-06	432	272	808	0.33	0.06	520	25.81
28CB525	142438	212000	1000	37 E-06	517	286	860	0.33	0.06	560	27.81
30CB525	142439	242000	950	40 E-06	621	302	916	0.33	0.06	580	29.81
32CB525	142440	274000	900	43 E-06	736	321	966	0.33	0.06	620	31.81
36CB525	142441	344000	800	48 E-06	1052	366	1100	0.33	0.06	700	35.81
40CB525	142442	422000	750	52 E-06	1502	413	1220	0.33	0.06	760	39.81
45CB525	142443	520000	670	64 E-06	2293	537	1350	0.33	0.06	860	44.75

Size	Part Number	M. Torque Rating	Maximum Speed	C. Centrifugal Loss Constant	Wk ²	Weight	Friction Area	Friction Lining Thickness		AirTube Cavity	Minimum Drum Diameter
					J	Mass		New	Worn		
12CB350	142731	3010	1800	0,83 E-06	1,05	28	1651	5	2	2,62	302
14CB400	142604	4450	1800	1,04 E-06	1,76	34	2193	5	2	2,30	353
16CB500	142432	7960	1550	1,38 E-06	4,45	68	3109	7	2	4,59	403
18CB500	142433	9940	1400	1,59 E-06	6,05	75	3380	7	2	5,25	454
20CB500	142434	12100	1300	1,73 E-06	7,77	82	3715	7	2	5,58	505
22CB500	142435	14100	1250	1,93 E-06	9,79	88	4025	7	2	6,23	555
24CB500	142436	17000	1200	2,07 E-06	12,26	95	4360	7	2	6,56	606
26CB525	142437	20900	1050	2,35 E-06	18,14	123	5212	8	2	8,53	656
28CB525	142438	24000	1000	2,55 E-06	21,71	130	5547	8	2	9,18	706
30CB525	142439	27300	950	2,76 E-06	26,08	137	5908	8	2	9,51	757
32CB525	142440	31000	900	2,97 E-06	30,91	145	6231	8	2	10,2	808
36CB525	142441	38900	800	3,31 E-06	44,18	166	7095	8	2	11,5	910
40CB525	142442	47700	750	3,59 E-06	63,08	187	7869	8	2	12,5	1011
45CB525	142443	58800	670	4,42 E-06	96,31	243	8708	8	2	14,1	1137

SI		N · m @ 5,2bar	rpm	bar/rpm ²	kg · m ²	kg	cm ²	millimeters		dm ³	millimeters
----	--	-------------------	-----	----------------------	---------------------	----	-----------------	-------------	--	-----------------	-------------

Notes:

- ❶ Refers to basic part number only. When ordering, the number of air inlets and type of connection must be specified.
- ❷ Dynamic torque shown, static torque approximately 25% greater. Torque in each application is dependent upon air pressure and speed.
- ❸ Tolerance for sizes:
12 thru 24, 28 and 32
+0.000/-0.005 in (+0,00/-0,13 mm)
26 and 30
+0.000/-0.008 in (+0,00/-0,20 mm)
36 thru 45
+0.000/-0.010 in (+0,00/-0,25 mm)
- ❹ American National Pipe Thread
Sizes 12 and 14 available with two air inlets. All other sizes available with two or four air inlets.
- ❺ 10.00 degrees for elements with one air inlet. 5.00 degrees for elements with two or four air inlets.
- ❻ Maximum rpm is dependent upon operating conditions and varies for each application. Consult factory for applications exceeding these speeds.
- ❼ Drum contact with worn shoes.

Airflex® Dual CBElements

Form CB-403 Dimensional Data — Sizes 12 to 45

Section B

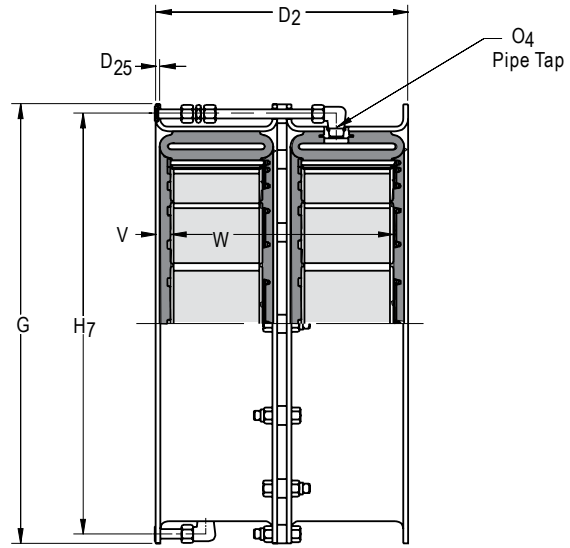
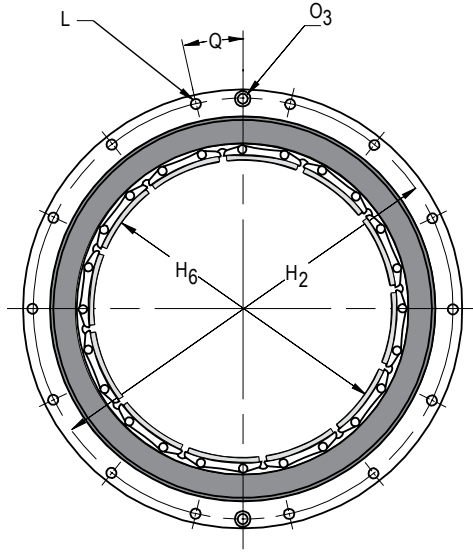

English	lb · in @75psi	Dimensions in inches														
12CB350	142731	26600	10.13	0.19	17.625	16.875	12.13	16.88	14	0.375	0.31	3/8-18	12.857	0.69	24	8.75
14CB400	142604	39400	11.13	0.19	19.625	18.875	14.13	18.88	16	0.375	0.31	3/8-18	11.250	0.69	28	9.75
16CB500	142432	70400	13.63	0.19	23.500	22.500	16.19	22.25	8	0.500	0.38	3/8-18	22.500	0.81	20	12.00
18CB500	142433	88000	13.63	0.19	25.500	24.375	18.19	24.38	12	0.500	0.38	3/8-18	15.000	0.81	22	12.00
20CB500	142434	107200	13.63	0.19	27.500	26.375	20.19	26.38	12	0.500	0.38	3/8-18	15.000	0.81	24	12.00
22CB500	142435	124600	13.63	0.19	29.500	28.375	22.19	28.38	12	0.500	0.38	3/8-18	15.000	0.81	26	12.00
24CB500	142436	150000	13.63	0.19	31.500	30.375	24.19	30.38	16	0.500	0.38	3/8-18	11.250	0.81	28	12.00
26CB525	142437	184800	14.25	0.25	34.000	32.750	26.19	32.50	16	0.625	0.50	1/2-14	11.250	0.84	32	12.56
28CB525	142438	212000	14.44	0.25	36.000	34.750	28.19	34.50	16	0.625	0.50	1/2-14	11.250	0.84	34	12.69
30CB525	142439	242000	14.44	0.25	38.000	36.750	30.19	36.50	16	0.625	0.50	1/2-14	11.250	0.84	36	12.69
32CB525	142440	274000	14.44	0.25	40.000	38.750	32.19	38.50	18	0.625	0.50	1/2-14	9	0.84	38	12.69
36CB525	142441	344000	14.44	0.25	44.625	43.125	36.19	43.25	18	0.750	0.63	3/4-14	9	0.84	44	12.69
40CB525	142442	422000	14.44	0.25	48.625	47.125	40.19	47.25	20	0.750	0.63	3/4-14	9.000	0.84	48	12.69
45CB525	142443	520000	14.44	0.28	53.625	52.125	45.19	52.25	24	0.750	0.63	3/4-14	7.500	0.84	54	12.69

Size	Part Number	M ^r Torque Rating	D ₂	D ₂₅	G	H ₂	H ₃	H ₇	L (Bolt)		O ₃	O ₄	Q (Deg)	V	W	
									No.	Size						No.
12CB350	142731	3010	257	5	447,7	428,6	308	429	14	10	8	3/8-18	12,857	17	24	222
14CB400	142604	4450	283	5	498,5	479,4	359	479	16	10	8	3/8-18	11,250	17	28	248
16CB500	142432	7960	346	5	596,9	571,5	411	565	8	13	10	3/8-18	22,500	21	20	305
18CB500	142433	9940	346	5	647,7	619,1	462	619	12	13	10	3/8-18	15,000	21	22	305
20CB500	142434	12100	346	5	698,5	669,9	513	670	12	13	10	3/8-18	15,000	21	24	305
22CB500	142435	14100	346	5	749,3	720,7	564	721	12	13	10	3/8-18	15,000	21	26	305
24CB500	142436	17000	346	5	800,1	771,5	614	772	16	13	10	3/8-18	11,300	21	28	305
26CB525	142437	20900	362	6	863,6	831,9	665	826	16	16	13	1/2-14	11,300	21	32	319
28CB525	142438	24000	367	6	914,4	882,7	716	876	16	16	13	1/2-14	11,300	21	34	322
30CB525	142439	27300	367	6	965,2	933,5	767	927	16	16	13	1/2-14	11,300	21	36	322
32CB525	142440	31000	367	6	1016,0	984,3	818	978	18	16	13	1/2-14	9	21	38	322
36CB525	142441	38900	367	6	1133,5	1095,4	919	1099	18	19	16	3/4-14	9	21	44	322
40CB525	142442	47700	367	6	1235,1	1197,0	1021	1200	20	19	16	3/4-14	9,000	21	48	322
45CB525	142443	58800	367	7	1362,1	1324,0	1148	1327	24	19	16	3/4-14	7,500	21	54	322

SI **N · m**
@ 5,2bar **Dimensions in millimeters**

Airflex®CB Clutch Application

Form CB-405 Close-Mounted Arrangement —

Technical Data — Sizes 6 to 14

Section B

Size	Part Numbers Element Assembly		Integral Drum and Hub	Spider	
	One inlet	Two inlets		One inlet	Two inlets
6CB200	142095JB	142095JG	10108	408367	408368
8CB250	142096JB	142096JG	10109	408369	408370
10CB300	142197JB	142197JG	10110	408371	408372
12CB350	142098JB	142098JG	10111	408373	408374
14CB400	142087JB	142087JG	9617	408375	408376

English ⑥	lb	lb · ft ²	lb	lb · ft ²	lb	lb · ft ²
6CB200	7	1	10	0.3	15	1.2
8CB250	9	2	19	0.8	19	2.3
10CB300	19	6	33	2.5	40	5.3
12CB350	26	11	53	5.4	46	8.1
14CB400	31	17	65	8.5	50	11.2

Size	Weight		Wk ²		Weight		Wk ²		
	Element	Mass	J	Integral Drum and Hub	Mass	J	Spider	Mass	J
6CB200	3,2	0,04	0,04	4,5	0,01	0,01	6,8	0,05	0,05
8CB250	4,1	0,08	0,08	8,6	0,03	0,03	8,6	0,10	0,10
10CB300	8,6	0,25	0,25	15	0,11	0,11	18	0,22	0,22
12CB350	12	0,46	0,46	24	0,23	0,23	21	0,34	0,34
14CB400	14	0,71	0,71	29	0,36	0,36	23	0,47	0,47
SI ⑥	kg	kg · m ²	kg · m ²	kg	kg · m ²	kg · m ²	kg	kg · m ²	kg · m ²

Notes:

- ① Refers to basic part number only and does not include the rotor seal and hose. When ordering, the number of element connections must be specified.
- ② Dynamic torque shown, static torque approximately 25% greater. Torque in each application is dependent upon air pressure and speed.
- ③ Based upon minimum bores. Rotor seal and hose not included.

- ④ Refer to Rotor seal Section for mounting and dimension information.
- ⑤ $M = 0.268 (H/2 - \text{radius of bore}) + Y1$
- ⑥ Based upon minimum bores.

Airflex® CB Clutch Application

Form CB-405 Close-Mounted Arrangement —

Dimensional Data — Sizes 6 to 14

Section B

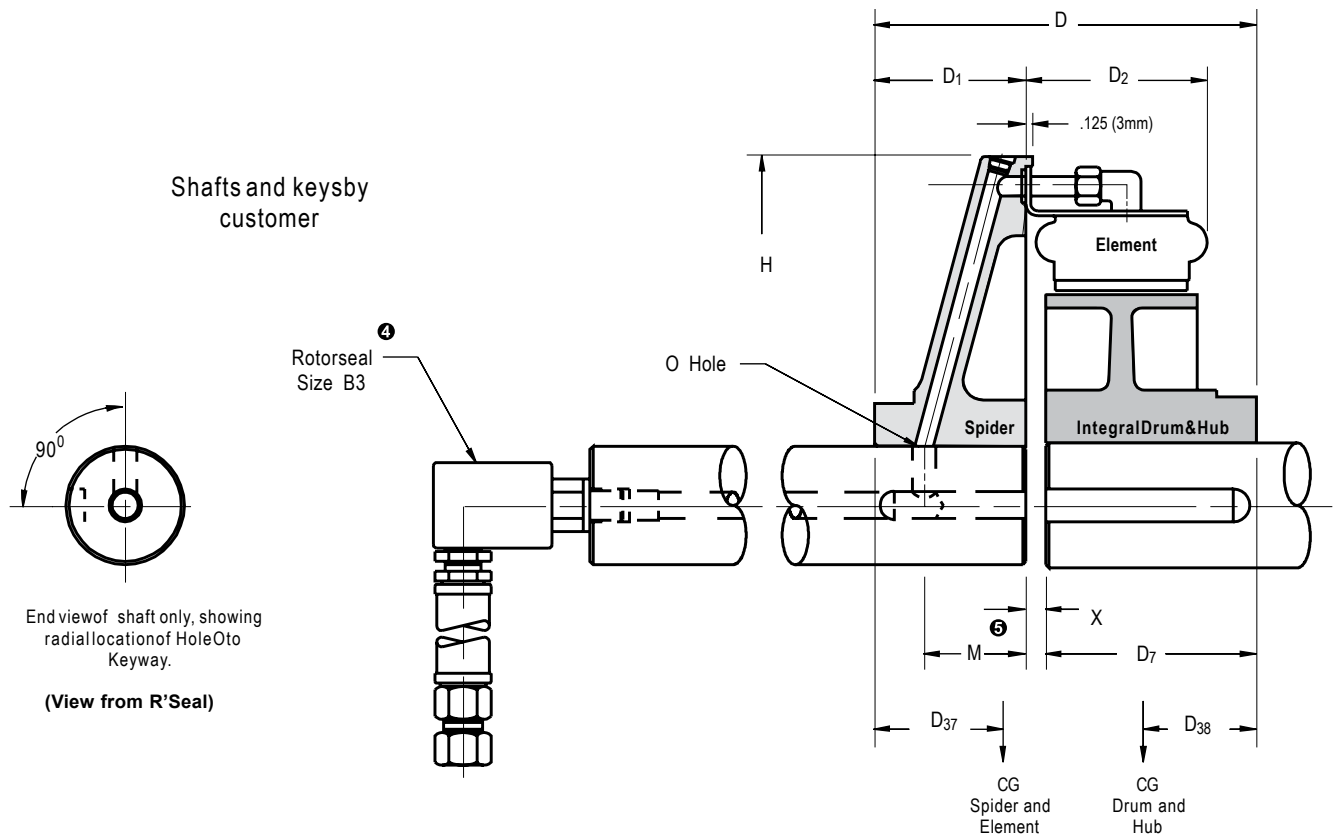

English	Part Number	lb · in @75psi	lb	Dimensions in inches											
6CB200	104119	2040	32	1.00	2.50	5.63	2.38	2.94	2.88	2.40	1.50	11.13	0.44	0.38	0.34
8CB250	104120	4290	47	1.00	2.88	6.75	2.88	3.44	3.50	2.70	1.90	13.25	0.44	0.38	0.41
10CB300	104121	8150	92	1.25	3.31	8.00	3.56	4.13	4.00	2.50	2.10	15.75	0.44	0.44	0.41
12CB350	104122	13300	125	1.50	3.31	8.94	4.00	4.72	4.50	3.20	2.30	18.00	0.44	0.44	0.34
14CB400	104123	19700	146	2.00	4.25	9.96	4.34	5.22	5.00	3.40	2.60	20.00	0.44	0.56	0.34

Size	Part Number	lb · in @75psi	lb	Bore Range		D	D ₁	D ₂	D ₇	D ₃₇	D ₃₈	H	O	X	Y ₁
				Min.	Max.										
6CB200	104119	231	14	25	64	143	60	75	73	61	38	283	11	10	9
8CB250	104120	485	21	25	73	171	73	87	89	69	48	337	11	10	10
10CB300	104121	921	42	32	84	203	90	105	102	64	53	400	11	11	10
12CB350	104122	1500	57	38	84	227	102	120	114	81	58	457	11	11	9
14CB400	104123	2230	66	51	108	253	110	133	127	86	66	508	11	14	9

SI	Part Number	N · m @ 5,2 bar	kg	Dimensions in millimeters											
----	-------------	--------------------	----	---------------------------	--	--	--	--	--	--	--	--	--	--	--

Airflex®CB Clutch Application

Form CB-404 Gap-Mounted Arrangement

Section B

Size	Part Numbers					
	Element Assembly		Drum	Drum Hub	Spider	
	One inlet	Two inlets			One inlet	Two inlets
6CB200	142095JB	142095JG	407044	408414	408367	408368
8CB250	142096JB	142096JG	407046	406900	408369	408370
10CB300	142197JB	142197JG	407048	406902	408371	408372
12CB350	142098JB	142098JG	407050	406902	408373	408374
14CB400	142087JB	142087JG	407052	406904	408375	408376

English Ⓞ	lb	lb · ft ²	lb	lb · ft ²	lb	lb · ft ²	lb	lb · ft ²
6CB200	7	1	5.5	0.3	8	0.1	15	1.2
8CB250	9	2	12.5	1.1	11	0.3	19	2.3
10CB300	19	6	19	2.7	22	0.8	40	5.3
12CB350	26	11	30	5.9	22	0.8	46	8.1
14CB400	31	17	38	10.5	54	3.2	50	11.2
Size	Weight	Wk ²	Weight	Wk ²	Weight	Wk ²	Weight	Wk ²
	Element		Drum		Drum Hub		Spider	
	Mass	J	Mass	J	Mass	J	Mass	J
6CB200	3,2	0,04	2,5	0,01	3,6	0,00	6,8	0,05
8CB250	4,1	0,08	5,7	0,05	5,0	0,01	8,6	0,10
10CB300	8,6	0,25	8,6	0,11	10,0	0,03	18	0,22
12CB350	12	0,46	14	0,25	10,0	0,03	21	0,34
14CB400	14	0,71	17	0,44	24	0,13	23	0,47
SI Ⓞ	Kg	kg · m ²	Kg	kg · m ²	Kg	kg · m ²	Kg	kg · m ²

Notes:

- ❶ Refers to basic part number only and does not include the rotor seal and hose. When ordering, the number of element connections must be specified.
- ❷ Dynamic torque shown, static torque approximately 25% greater. Torque in each application is dependent upon air pressure and speed.
- ❸ Based upon minimum bores. Rotor seal and hose not included.
- ❹ Refer to Rotor seal Section for mounting and dimension information.
- ❺ $M = 0.268 (H/2 - \text{radius of bore}) + Y1$
- ❻ Based upon minimum bores.

Airflex® CB Clutch Application

Form CB-404 Gap-Mounted Arrangement —

Dimensional Data — Sizes 6 to 14

Section B

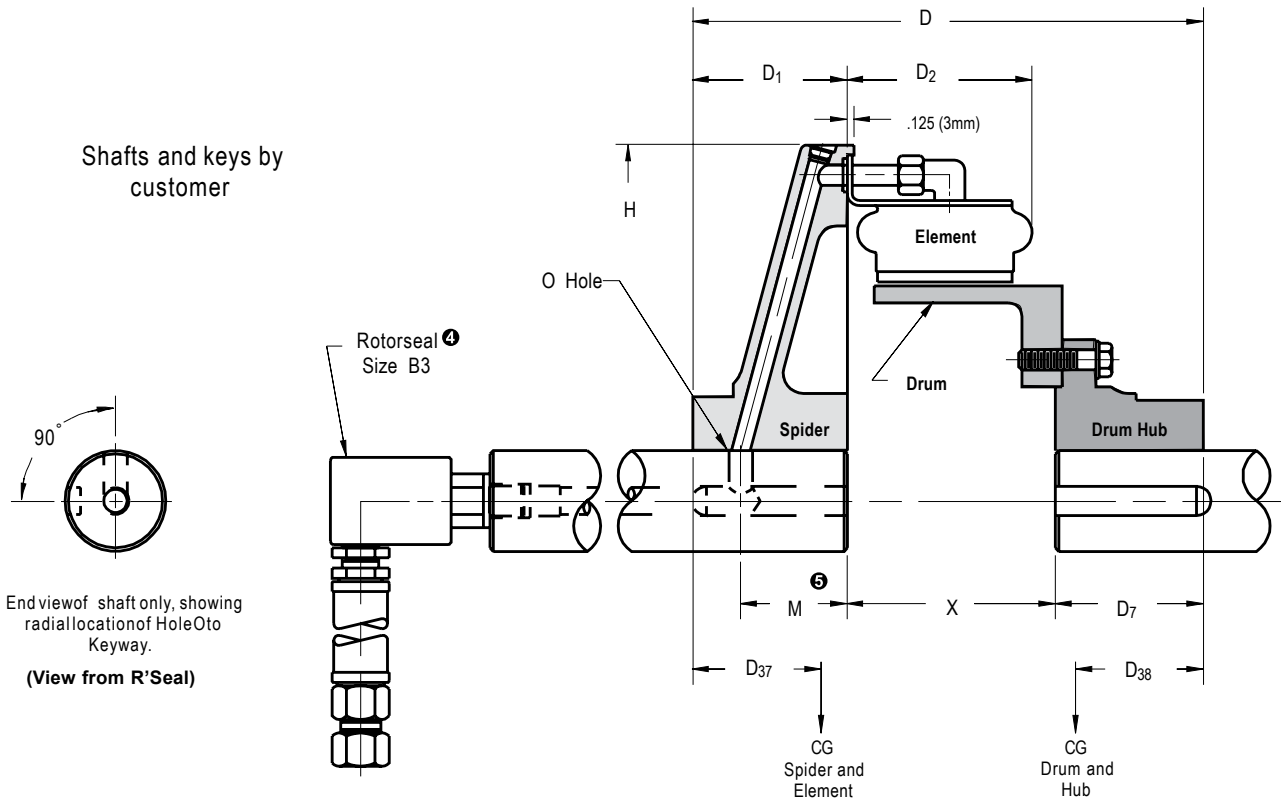

English		lb · in @75psi	⊕ lb	Dimensions in inches											
6CB200	104114	2040	35.5	1.00	2.50	8.38	2.38	2.94	2.75	2.40	2.40	11.13	0.44	3.25	0.34
8CB250	104115	4290	51.5	1.00	2.88	9.38	2.88	3.44	2.75	2.70	2.70	13.25	0.44	3.75	0.41
10CB300	104116	8150	100	1.25	3.31	11.19	3.56	4.13	3.25	2.50	3.20	15.75	0.44	4.38	0.41
12CB350	104117	13300	124	1.50	3.31	12.25	4.00	4.72	3.25	3.20	3.50	18.00	0.44	5.00	0.34
14CB400	104118	19700	173	2.00	4.25	14.84	4.34	5.22	5.00	3.40	4.30	20.00	0.44	5.50	0.34

Size	⊕ Part Number	⊕ M _t Torque Rating	Weight — Mass	Bore Range		D	D ₁	D ₂	D ₇	D ₃₇	D ₃₈	H	O	X	Y ₁
				Min.	Max.										
6CB200	104114	231	16	25	64	213	60	75	70	61	61	283	11	83	9
8CB250	104115	485	23	25	73	238	73	87	70	69	69	337	11	95	10
10CB300	104116	921	45	32	84	284	90	105	83	64	81	400	11	111	10
12CB350	104117	1500	56	38	84	311	102	120	83	81	89	457	11	127	9
14CB400	104118	2230	78	51	108	377	110	133	127	86	109	508	11	140	9

SI		N · m @ 5,2 bar	⊕ kg	Dimensions in millimeters											
----	--	--------------------	---------	---------------------------	--	--	--	--	--	--	--	--	--	--	--

Airflex®CB Clutch Application

Form CB-406 Gap-Mounted Arrangement —

Technical Data — Sizes 16 to 45

Section B

Size	Part Numbers				
	Element Assembly		Drum	Drum Hub	Spider
	One inlet	Four inlets			
16CB500	142211KM	142211KP	407053	406906	408276
18CB500	142264KM	142264KP	408285	406908	408277
20CB500	142265KM	142265KP	407055	406910	408278
22CB500	142266KM	142266KP	408287	406912	408279
24CB500	142267KM	142267KP	407057	406914	408280
26CB525	142268KM	142268KP	408289	406916	408281

Size	Part Numbers				
	Element Assembly		Drum	Drum Hub	Spider
	One inlet	Four inlets			
28CB525	142269KM	142269KP	407059	406918	408282
30CB525	142270KM	142270KP	408343	406920	407096
32CB525	142271KM	142271KP	407061	406922	407097
36CB525	142272KM	142272KP	407063	406924	407098
40CB525	142273KM	142273KP	407065	406926	407099
45CB525	142081KM	142081KP	407067	406928	502369

English Ø	lb	lb · ft ²	lb	lb · ft ²	lb	lb · ft ²	lb	lb · ft ²
16CB500	74	52	50	19	74	6.6	146	53
18CB500	81	70	67	31	83	9	152	63
20CB500	88	90	72	43	97	16	183	91
22CB500	95	114	79	58	133	25	227	123
24CB500	102	142	93	80	142	33	257	150
26CB525	133	210	108	110	164	43	298	220
28CB525	140	252	117	140	172	55	337	270
30CB525	148	303	140	192	213	69	341	390
32CB525	157	359	160	252	234	97	392	453
36CB525	178	510	160	319	319	157	505	710
40CB525	201	730	209	523	344	214	464	774
45CB525	262	1115	237	758	491	379	1294	1887

Size	Weight		Wk ²		Weight		Wk ²	
	Element Assembly		Drum		Drum Hub		Spider	
	Mass	J	Mass	J	Mass	J	Mass	J
16CB500	34	2,18	23	0,80	34	0,28	66	2,23
18CB500	37	2,94	30	1,30	38	0,38	69	2,65
20CB500	40	3,78	33	1,81	44	0,67	83	3,82
22CB500	43	4,79	36	2,44	60	1,05	103	5,17
24CB500	46	5,96	42	3,36	64	1,39	116	6,30
26CB525	60	8,82	49	4,62	74	1,81	135	9,24
28CB525	63	10,58	53	5,88	78	2,31	153	11,34
30CB525	67	12,73	63	8,06	96	2,90	154	16,38
32CB525	71	15,08	72	10,58	106	4,07	178	19,03
36CB525	81	21,42	72	13,40	145	6,59	229	29,82
40CB525	91	30,66	95	21,97	156	8,99	210	32,51
45CB525	119	46,83	107	31,84	222	15,92	586	79,25
SI Ø	Kg	kg · m ²	Kg	kg · m ²	Kg	kg · m ²	Kg	kg · m ²

Notes:

- ❶ Refers to basic part number only and does not include the rotor seal and hose. When ordering, the number and type of element connections must be specified.
- ❷ Dynamic torque shown, static torque approximately 25% greater. Torque in each application is dependent upon air pressure and speed.
- ❸ Based upon minimum bores. Rotor seal and hose not included.

- ❹ American National Pipe Thread
- ❺ Refer to Rotor seal Section for mounting and dimension information.
- ❻ Refer to CB Spider Piping and Configuration catalog page for other sizes.
- ❼ Based upon minimum bores.

Airflex® CB Clutch Application

Form CB-406 Gap-Mounted Arrangement —

Dimensional Data — Sizes 16 to 45

Section B

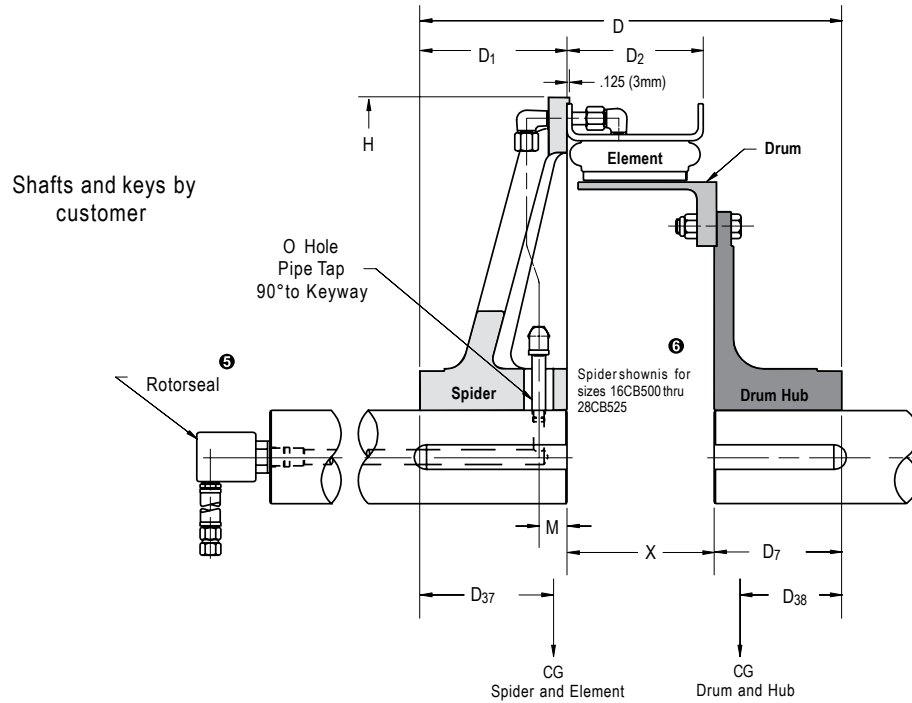

English		lb · in @75psi		lb [ⓐ]	Dimensions in inches											
16CB500	104124	35200	C2	344	2.00	4.88	18.31	5.50	6.63	5.75	5.20	5.30	24.00	1.44	3/8-18	7.06
18CB500	104125	44000	C2	383	2.25	5.00	18.31	5.50	6.63	5.75	5.30	5.40	26.00	1.44	3/8-18	7.06
20CB500	104126	53600	C2	440	2.50	5.00	18.31	5.50	6.63	5.75	5.30	5.50	28.00	1.44	3/8-18	7.06
22CB500	104127	62300	C2	534	2.75	5.69	19.56	6.00	6.63	6.50	5.40	5.80	30.00	1.44	3/8-18	7.06
24CB500	104128	75000	C2	594	2.75	5.69	20.06	6.50	6.63	6.50	5.60	5.90	32.00	1.44	3/8-18	7.06
26CB525	104129	92400	C2	703	2.75	5.69	20.50	6.50	6.94	6.50	5.90	6.00	34.63	1.44	3/8-18	7.50
28CB525	104130	106000	C2	766	2.75	5.69	21.50	7.50	6.94	6.50	6.60	6.00	36.63	1.44	3/8-18	7.50
30CB525	104131	121000	C2	842	3.00	6.31	23.00	7.50	6.94	8.00	6.80	7.20	38.63	1.44	3/8-18	7.50
32CB525	104132	137000	C2	943	3.00	6.06	23.00	7.50	6.94	8.00	6.60	7.40	40.63	1.44	3/8-18	7.50
36CB525	104133	172000	C2	1162	4.00	7.00	25.00	8.50	6.94	9.00	7.10	7.70	45.25	1.44	1/2-14	7.50
40CB525	104134	211000	3/4 RH	1218	4.00	7.00	25.00	8.50	6.94	9.00	7.60	8.10	49.25	1.44	1/2-14	7.50
45CB525	104135	260000	3/4 RH	2284	4.38	9.88	28.50	11.00	6.94	10.00	8.80	8.30	54.25	6.00	1/2-14	7.50

Size	Part [ⓐ] Number	M [ⓐ] Torque Rating	Rotorseal Size	Weight		Dimensions in inches											
				Mass	Bore Range	D	D ₁	D ₂	D ₇	D ₃₇	D ₃₈	H	M	O	X		
						Min.	Max.										
16CB500	104124	3980	C2	156	51	124	465	140	168	146	132	135	610	37	3/8-18	179	
18CB500	104125	4970	C2	173	57	127	465	140	168	146	135	137	660	37	3/8-18	179	
20CB500	104126	6060	C2	199	64	127	465	140	168	146	135	140	711	37	3/8-18	179	
22CB500	104127	7040	C2	242	70	144	497	152	168	165	137	147	762	37	3/8-18	179	
24CB500	104128	8480	C2	269	70	144	510	165	168	165	142	150	813	37	3/8-18	179	
26CB525	104129	10400	C2	318	70	144	521	165	176	165	150	152	879	37	3/8-18	191	
28CB525	104130	12000	C2	347	70	144	546	191	176	165	168	152	930	37	3/8-18	191	
30CB525	104131	13700	C2	381	76	160	584	191	176	203	173	183	981	37	3/8-18	191	
32CB525	104132	15500	C2	427	76	154	584	191	176	203	168	188	1032	37	3/8-18	191	
36CB525	104133	19400	C2	526	102	178	635	216	176	229	180	196	1149	37	1/2-14	191	
40CB525	104134	23800	3/4 RH	552	102	178	635	216	176	229	193	206	1251	37	1/2-14	191	
45CB525	104135	29400	3/4 RH	1035	111	251	724	279	176	254	224	211	1378	152	1/2-14	191	

SI N · m @ 5,2 bar lb[ⓐ] kg Dimensions in millimeters

Airflex® CB Clutch Application

Form CB-407 Gap-Mounted Arrangement —

Technical Data — Sizes Dual 12 to Dual 45

Section B

Size	Part Numbers				
	Element Assembly		Drum	Drum Hub	Spider
	Two inlets	Four inlets			
12CB350	142731DA		411860	406902	408374
14CB400	142604DA		411861	406904	408376
16CB500	142432DA	142432DK	411862	406906	408276
18CB500	142433DA	142433DK	411863	406908	408277
20CB500	142434DA	142434DK	411864	406910	408278
22CB500	142435DA	142435DK	411865	406912	408279
24CB500	142436DA	142436DK	411866	406914	408280

Size	Part Numbers				
	Element Assembly		Drum	Drum Hub	Spider
	Two inlets	Four inlets			
26CB525	142437DA	142437DK	411867	406916	408281
28CB525	142438DA	142438DK	411868	406918	408282
30CB525	142439DA	142439DK	411869	406920	407096
32CB525	142440DA	142440DK	411870	406922	407097
36CB525	142441DA	142441DK	411871	406924	407098
40CB525	142442DA	142442DK	411872	406926	407099
45CB525	142443DA	142443DK	411873	406928	502369

English Ø	lb	lb · ft ²	lb	lb · ft ²	lb	lb · ft ²	lb	lb · ft ²
12CB350	58	24	61	13	22	0.8	46	8.1
14CB400	75	42	83	24	54	3.2	50	11.2
16CB500	151	106	109	43	74	6.6	146	53
18CB500	166	144	126	63	83	9	152	63
20CB500	180	185	139	87	97	16	183	91
22CB500	194	233	152	117	133	25	227	123
24CB500	209	292	173	156	142	33	257	150
26CB525	272	432	198	211	164	43	298	220
28CB525	286	517	216	268	172	55	337	270
30CB525	302	621	237	337	213	69	341	390
32CB525	321	736	254	413	234	97	392	453
36CB525	366	1052	287	597	319	157	505	710
40CB525	413	1502	327	840	344	214	464	774
45CB525	537	2293	369	1212	491	379	1294	1887

Size	Weight		Wk ²		Weight		Wk ²	
Element Assembly	Mass	J	Drum		Drum Hub		Spider	
			Mass	J	Mass	J	Mass	J
12CB350	26	1,01	28	0,55	10	0,03	21	0,34
14CB400	34	1,76	38	1,01	24	0,13	23	0,47
16CB500	68	4,45	49	1,81	34	0,28	66	2,23
18CB500	75	6,05	57	2,65	38	0,38	69	2,65
20CB500	82	7,77	63	3,65	44	0,67	83	3,82
22CB500	88	9,79	69	4,91	60	1,05	103	5,17
24CB500	95	12,26	78	6,55	64	1,39	116	6,30
26CB525	123	18,14	90	8,86	74	1,81	135	9,24
28CB525	130	21,71	98	11,26	78	2,31	153	11,34
30CB525	137	26,08	107	14,15	96	2,90	154	16,38
32CB525	145	30,91	115	17,35	106	4,07	178	19,03
36CB525	166	44,18	130	25,07	145	6,59	229	29,82
40CB525	187	63,08	148	35,28	156	8,99	210	32,51
45CB525	243	96,31	167	50,90	222	15,92	586	79,25

Notes:

- ① Refers to basic part number only and does not include the rotor seal and hose. When ordering, the number and type of element connections must be specified.
- ② Dynamic torque shown, static torque approximately 25% greater. Torque in each application is dependent upon air pressure and speed.
- ③ Based upon minimum bores. Rotor seal and hose not included.
- ④ $M \text{ (in)} = 0.268 (H/2 - \text{radius of bore}) + 0.34$
 $M \text{ (mm)} = 0.268 (H/2 - \text{radius of bore}) + 8,7$

- ⑤ American National Pipe Thread
- ⑥ Pipe tap not required. Thru hole diameter 0.44 in (11 mm).
- ⑦ Refer to Rotor seal Section for mounting and dimension information.
- ⑧ Refer to CB Spider Piping and Configuration catalog page for other sizes.
- ⑨ Based upon minimum bores.

Airflex® CB Clutch Application

Form CB-407 Gap — Mounted Arrangement —

Dimensional Data — Sizes Dual 12 to Dual 45

Section B

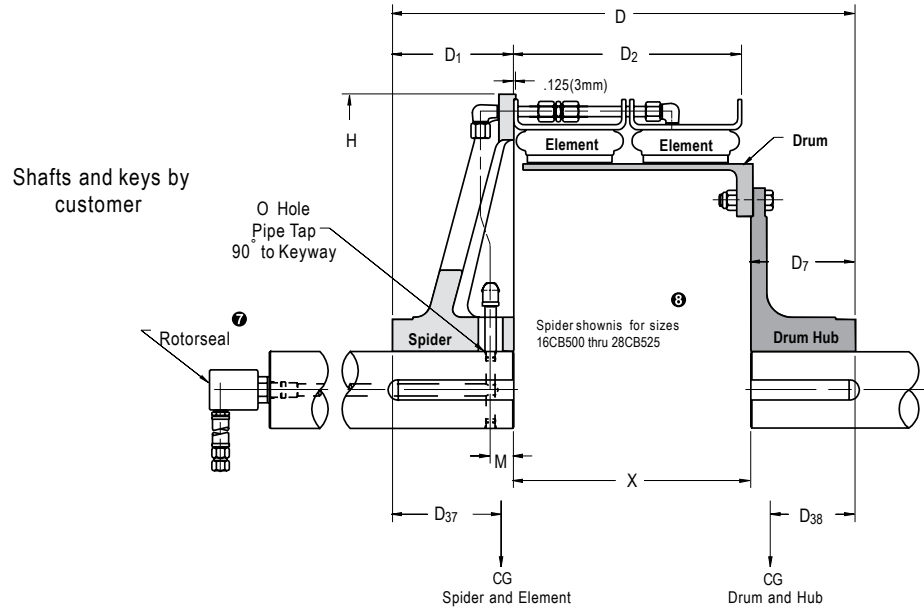

English	lb · in @75psi	lb [ⓐ]	Dimensions in inches												
12CB350	105480	26600	C2	187	1.50	2.63	17.75	4.00	10.13	3.25	6.20	5.80	18.00	ⓐ	10.50
14CB400	105481	39400	C2	262	2.00	3.56	20.84	4.34	11.13	5.00	7.40	6.70	20.00	ⓐ	11.50
16CB500	105482	70400	C2	480	2.00	4.13	25.25	5.50	13.63	5.75	8.00	8.00	24.00	1.44	3/8-18
18CB500	105483	88000	C2	527	2.25	4.38	25.25	5.50	13.63	5.75	8.10	8.00	26.00	1.44	3/8-18
20CB500	105522	107200	C2	599	2.50	3.81	25.25	5.50	13.63	5.75	7.70	8.10	28.00	1.44	3/8-18
22CB500	105484	124600	C2	706	2.75	4.50	26.50	6.00	13.63	6.50	7.90	8.30	30.00	1.44	3/8-18
24CB500	105485	150000	C2	781	2.75	4.50	27.00	6.50	13.63	6.50	8.10	8.30	32.00	1.44	3/8-18
26CB525	105486	184800	3/4 RH	932	2.75	4.50	27.63	6.50	14.25	6.50	8.70	8.40	34.63	1.44	3/8-18 14.63
28CB525	105487	212000	3/4 RH	1011	2.75	3.81	28.75	7.50	14.44	6.50	9.30	8.70	36.63	1.44	3/8-18 14.75
30CB525	105488	242000	3/4 RH	1093	3.00	4.50	30.25	7.50	14.44	8.00	9.50	9.50	38.63	1.44	3/8-18 14.75
32CB525	105489	274000	3/4 RH	1201	3.00	4.00	30.25	7.50	14.44	8.00	9.30	9.70	40.63	1.44	3/8-18 14.75
36CB525	105490	344000	3/4 RH	1477	4.00	5.75	32.25	8.50	14.44	9.00	9.70	9.90	45.25	1.44	1/2-14 14.75
40CB525	105491	422000	1 RH	1548	4.00	4.88	32.25	8.50	14.44	9.00	10.40	10.10	49.25	1.44	1/2-14 14.75
45CB525	105492	520000	1 RH	2691	4.38	8.00	35.75	11.00	14.44	10.00	10.70	10.10	54.25	6.00	1/2-14 14.75

Size	Part [ⓐ] Number	M [ⓐ] Torque Rating	Rotorseal Size	Weight		Dimensions in millimeters												
				Mass	Bore Range	D	D ₁	D ₂	D ₇	D ₃₇	D ₃₈	H	M	ⓐ	X			
				Min. Max.														
12CB350	105480	3010	C2	85	38	67	451	102	257	83	157	147	457	ⓐ	ⓐ	267		
14CB400	105481	4450	C2	119	51	90	529	110	283	127	188	170	508	ⓐ	ⓐ	292		
16CB500	105482	7960	C2	217	51	105	641	140	346	146	203	203	610	37	3/8-18	356		
18CB500	105483	9940	C2	239	57	111	641	140	346	146	206	203	660	37	3/8-18	356		
20CB500	105522	12100	C2	271	64	97	641	140	346	146	196	206	711	37	3/8-18	356		
22CB500	105484	14100	C2	320	70	114	673	152	346	165	201	211	762	37	3/8-18	356		
24CB500	105485	17000	C2	354	70	114	686	165	346	165	206	211	813	37	3/8-18	356		
26CB525	105486	20900	3/4 RH	422	70	114	702	165	362	165	221	213	879	37	3/8-18	372		
28CB525	105487	24000	3/4 RH	458	70	97	730	191	367	165	236	221	930	37	3/8-18	375		
30CB525	105488	27300	3/4 RH	495	76	114	768	191	367	203	241	241	981	37	3/8-18	375		
32CB525	105489	31000	3/4 RH	544	76	102	768	191	367	203	236	246	1032	37	3/8-18	375		
36CB525	105490	38900	3/4 RH	669	102	146	819	216	367	229	246	251	1149	37	1/2-14	375		
40CB525	105491	47700	1 RH	701	102	124	819	216	367	229	264	257	1251	37	1/2-14	375		
45CB525	105492	58800	1 RH	1219	111	203	908	279	367	254	272	257	1378	152	1/2-14	375		

SI N · m @ 5,2 bar kg Dimensions in millimeters

Airflex®CB Clutch Application

Form CB-408 Gap — Engine Mounted Arrangement —

Technical Data — Sizes 12 to 45

Section B

Size	Part Numbers			
	Element Assembly		Drum	Spider
	Two inlets	Four inlets		
12CB350	142098JB	142098JG Os	411778	408373ls●
14CB400	142087JB	142087JG Os	411779	408375ns■
16CB500	142211KM	142211KP	411780	408276
18CB500	142264KM	142264KP	411781	408277
20CB500	142265KM	142265KP	411782	408278
22CB500	142266KM	142266KP	411783	408279
24CB500	142267KM	142267KP	411784	408280

Size	Part Numbers			
	Element Assembly		Drum	Spider
	Two inlets	Four inlets		
26CB525	142268KM	142268KP	411786	408281
28CB525	142269KM	142269KP	411785	408282
30CB525	142270KM	142270KP	411787	407096
32CB525	142271KM	142271KP	411788	407097
36CB525	142272KM	142272KP	411789	407098
40CB525	142273KM	142273KP	411790	407099
45CB525	142081KM	142081KP	411791	502369

English ▲	lb	lb · ft ²	lb	lb · ft ²	lb	lb · ft ²
12CB350	30	12	26	6.4	46	8.1
14CB400	35	21	45	18	50	11.2
16CB500	74	52	63	31	146	53
18CB500	81	70	72	44	152	63
20CB500	88	90	126	102	183	91
22CB500	95	114	115	103	227	123
24CB500	102	142	130	139	257	150
26CB525	133	210	144	178	298	220
28CB525	140	252	143	200	337	270
30CB525	148	303	166	271	341	390
32CB525	157	359	177	327	392	453
36CB525	178	510	199	462	505	710
40CB525	201	730	220	631	464	774
45CB525	262	1115	248	893	1294	1887
Size	Weight	Wk ²	Weight	Wk ²	Weight	Wk ²
	Element		Drum		Spider	

SI ▲	kg	kg · m ²	kg	kg · m ²	kg	kg · m ²
12CB350	14	0,50	12	0,27	21	0,34
14CB400	16	0,88	20	0,76	23	0,47
16CB500	34	2,18	29	1,30	66	2,23
18CB500	37	2,94	33	1,85	69	2,65
20CB500	40	3,78	57	4,28	83	3,82
22CB500	43	4,79	52	4,33	103	5,17
24CB500	46	5,96	59	5,84	116	6,30
26CB525	60	8,82	65	7,48	135	9,24
28CB525	63	10,58	65	8,40	153	11,34
30CB525	67	12,73	75	11,38	154	16,38
32CB525	71	15,08	80	13,73	178	19,03
36CB525	81	21,42	90	19,40	229	29,82
40CB525	91	30,66	100	26,50	210	32,51
45CB525	119	46,83	112	37,51	586	79,25
Size	Mass	J	Mass	J	Mass	J
	Element		Drum		Spider	

Notes:

- ❶ Refers to basic part number only and does not include the rotorseal and hose. Element sizes 12 and 14 have either one or two inlets. All other sizes have either one or four air inlets.
- ❷ Dynamic torque shown, static torque approximately 25% greater. Torque in each application is dependent upon air pressure and speed.
- ❸ Based upon minimum bores. Rotorseal and hose not included.
- ❹ Drum flange tolerance +0.000/-0.003 in (+0,00/-0,08 mm).
- ❺ $M (in) = 0,268(H/2 - \text{radius of bore}) + 0,34$
 $M (mm) = 0,268(H/2 - \text{radius of bore}) + 8,7$

- Ⓔ American National Pipe Thread
- Ⓕ Pipe tap not required. Thru hole diameter 0.44 in (11 mm).
- Ⓖ Refer to Rotorseal Section for mounting and dimension information.
- Ⓗ Refer to CB Spider Piping and Configuration catalog page for other sizes.
- Ⓙ Part number for two inlets.
 - Part number for one inlet. Part number for two inlets - 408374.
- Part number for one inlet. Part number for two inlets - 408376.
- ▲ Based upon minimum bore.

Airflex® CB Clutch Application

Form CB-408 Gap — Engine Mounted Arrangement —

Dimensional Data — Sizes 12 to 45

Section B

Shafts and keys
by customer

Spiders shown for
sizes 16CB500 thru
28CB525

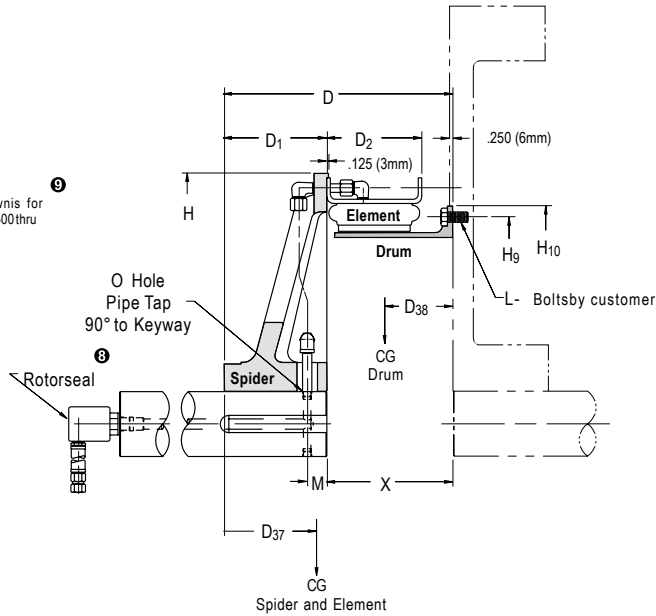

English	lb · in @ 75 psi	lb Ⓣ	Dimensions in inches																	
12CB350	104137	13300	B2	102	1.50	3.31	10.56	4.00	4.72	3.20	2.20	18.00	13.125	13.875	8	0.375	1.00	Ⓢ	Ⓣ	6.56
14CB400	104140	19700	B2	130	2.00	4.25	11.53	4.34	5.22	3.40	2.00	20.00	17.250	18.375	8	0.500	1.25	Ⓢ	Ⓣ	7.19
16CB500	104142	35200	C2	283	2.00	4.88	14.19	5.50	6.63	5.20	2.60	24.00	19.250	20.375	8	0.500	1.25	1.44	3/8-18	8.69
18CB500	104144	44000	C2	305	2.25	5.00	14.19	5.50	6.63	5.30	2.60	26.00	21.375	22.500	6	0.625	1.25	1.44	3/8-18	8.69
20CB500	104145	53600	C2	397	2.50	5.00	14.19	5.50	6.63	5.30	2.30	28.00	25.250	26.500	12	0.625	1.25	1.44	3/8-18	8.69
22CB500	104147	62300	C2	437	2.75	5.69	14.69	6.00	6.63	5.40	2.60	30.00	25.250	26.500	12	0.625	1.25	1.44	3/8-18	8.69
24CB500	104148	75000	C2	489	2.75	5.69	15.19	6.50	6.63	5.60	2.60	32.00	27.250	28.875	12	0.750	1.25	1.44	3/8-18	8.69
26CB525	104149	92400	C2	575	2.75	5.69	15.69	6.50	6.94	5.90	2.80	34.63	29.250	30.750	12	0.750	1.50	1.44	3/8-18	9.19
28CB525	104150	106000	C2	620	2.75	5.69	16.69	7.50	6.94	6.60	3.00	36.63	30.250	31.875	12	0.750	1.50	1.44	3/8-18	9.19
30CB525	104151	121000	C2	655	3.00	6.31	16.69	7.50	6.94	6.80	2.80	38.63	33.000	34.750	12	0.750	1.50	1.44	3/8-18	9.19
32CB525	105472	137000	C2	726	3.00	6.06	16.69	7.50	6.94	6.60	2.80	40.63	35.250	36.750	14	0.750	1.50	1.44	3/8-18	9.19
36CB525	105473	172000	C2	882	4.00	7.00	17.69	8.50	6.94	7.10	2.80	45.25	39.250	40.750	16	0.750	1.50	1.44	1/2-14	9.19
40CB525	104153	211000	3/4 RH	885	4.00	7.00	17.69	8.50	6.94	7.60	2.80	49.25	43.250	44.750	16	0.750	1.50	1.44	1/2-14	9.19
45CB525	105474	260000	3/4 RH	1804	4.38	9.88	20.19	11.00	6.94	8.80	2.90	54.25	48.250	49.750	16	0.750	1.50	6.00	1/2-14	9.19

Size	Ⓣ Part Number	M Ⓣ Torque Rating	Rotorseal Size	Weight Mass	Spider Bore	D	D ₁	D ₂	D ₃₇	D ₃₈	H	H ₉	H ₁₀	L (Bolt)	M	Ⓣ	X			
						Min.	Max.											No. Dia.	Length	
12CB350	104137	1500	B2	46	38	84	268	102	120	81	56	457	333,4	352,4	8	10	25	Ⓢ	Ⓣ	167
14CB400	104140	2230	B2	59	51	108	293	110	133	86	51	508	438,2	466,7	8	13	32	Ⓢ	Ⓣ	183
16CB500	104142	3980	C2	128	51	124	360	140	168	132	66	610	489,0	517,5	8	13	37	3/8-18	221	
18CB500	104144	4970	C2	158	57	127	360	140	168	135	66	660	542,9	571,5	6	16	37	3/8-18	221	
20CB500	104145	6060	C2	180	64	127	360	140	168	135	58	711	641,4	673,1	12	16	32	37	3/8-18	221
22CB500	104147	7040	C2	198	70	144	373	152	168	137	66	762	641,4	673,1	12	16	37	3/8-18	221	
24CB500	104148	8480	C2	222	70	144	386	165	168	142	66	813	692,2	733,4	12	19	37	3/8-18	221	
26CB525	104149	10400	C2	260	70	144	398	165	176	150	71	879	743,0	781,1	12	19	37	3/8-18	233	
28CB525	104150	12000	C2	281	70	144	424	191	176	168	76	930	768,4	809,6	12	19	37	3/8-18	233	
30CB525	104151	13700	C2	297	76	160	424	191	176	173	71	981	838,2	882,7	12	19	37	1/2-14	233	
32CB525	105472	15500	C2	329	76	154	424	191	176	168	71	1032	895,4	933,5	14	19	37	1/2-14	233	
36CB525	105473	19400	C2	400	102	178	449	216	176	180	71	1149	997,0	1035,1	16	19	38	37	1/2-14	233
40CB525	104153	23800	3/4 RH	401	102	178	449	216	176	193	71	1251	1098,6	1136,7	16	19	37	1/2-14	233	
45CB525	105474	29400	3/4 RH	817	111	251	513	279	176	224	74	1378	1225,6	1263,7	16	19	38	152	1/2-14	233

SI N · m @ 5,2 bar Ⓣ kg Dimensions in millimeters

Airflex®CB Clutch Application

Form CB427 Gap — Engine Mounted Arrangements —

Technical Data — Sizes Dual 12 to Dual 28

Section B

Size	Part Numbers		
	Element Assembly	Drum	Spider
	Two inlets	Four inlets	
12CB350	142731DA		408648 408374
14CB400	142604DA		411707 408376
16CB500	142432DA	142432DK	408682 408276
18CB500	142433DA	142433DK	410523 408277
20CB500	142434DA	142434DK	404605 408278
22CB500	142435DA	142435DK	406030 408279
24CB500	142436DA	142436DK	402145 408280
26CB525	142437DA	142437DK	411453 408281
28CB525	142438DA	142438DK	404942 408282

Size	English Units ^⑩					
	Element Ass'y		Drum		Spider	
	Weight lb	Wk ² lb · ft ²	Weight lb	Wk ² lb · ft ²	Weight lb	Wk ² lb · ft ²
12CB350	58	24	100	28	46	8.1
14CB400	75	42	103	47	50	11.2
16CB500	151	106	182	103	146	53
18CB500	166	144	201	126	152	63
20CB500	180	185	191	144	183	91
22CB500	194	233	186	159	227	123
24CB500	209	292	208	212	257	150
26CB525	272	432	234	278	298	220
28CB525	286	517	240	326	337	270

Size	SI Units ^⑩					
	Element Ass'y		Drum		Spider	
	Mass kg	J kg · m ²	Mass kg	J kg · m ²	Mass kg	J kg · m ²
12CB350	26	1,01	45	1,18	21	0,34
14CB400	34	1,76	47	1,97	23	0,47
16CB500	68	4,45	82	4,33	66	2,23
18CB500	75	6,05	91	5,29	69	2,65
20CB500	82	7,77	87	6,05	83	3,82
22CB500	88	9,79	84	6,68	103	5,17
24CB500	95	12,26	94	8,90	116	6,30
26CB525	123	18,14	106	11,68	135	9,24
28CB525	130	21,71	109	13,69	153	11,34

Notes:

- ❶ Refers to basic part number only and does not include the rotorseal and hose. Element sizes 12 and 14 have two inlets. All other sizes have either two or four air inlets.
- ❷ Dynamic torque shown, static torque approximately 25% greater. Torque in each application is dependent upon air pressure and speed.
- ❸ Based upon minimum bores. Rotorseal and hose not included.
- ❹ Drum flange tolerance +0.000/-0.003 in (+0,00/-0,08 mm).

- ❺ $M \text{ (in)} = 0.268 (H/2 - \text{radius of bore}) + 0.34$
 $M \text{ (mm)} = 0,268 (H/2 - \text{radius of bore}) + 8,7$
- ❻ American National Pipe Thread
- ❼ Pipe tap not required. Thru hole diameter 0.44 in (11 mm).
- ❽ Refer to Rotorseal Section for mounting and dimension information.
- ❾ Refer to CB Spider Piping and Configuration catalog page for other sizes.
- ❿ Based upon minimum bores.

Airflex® CB Clutch Application

Form CB427 — Engine Mounted Arrangements —

Dimensional Data — Sizes Dual 12 to Dual 28

Section B

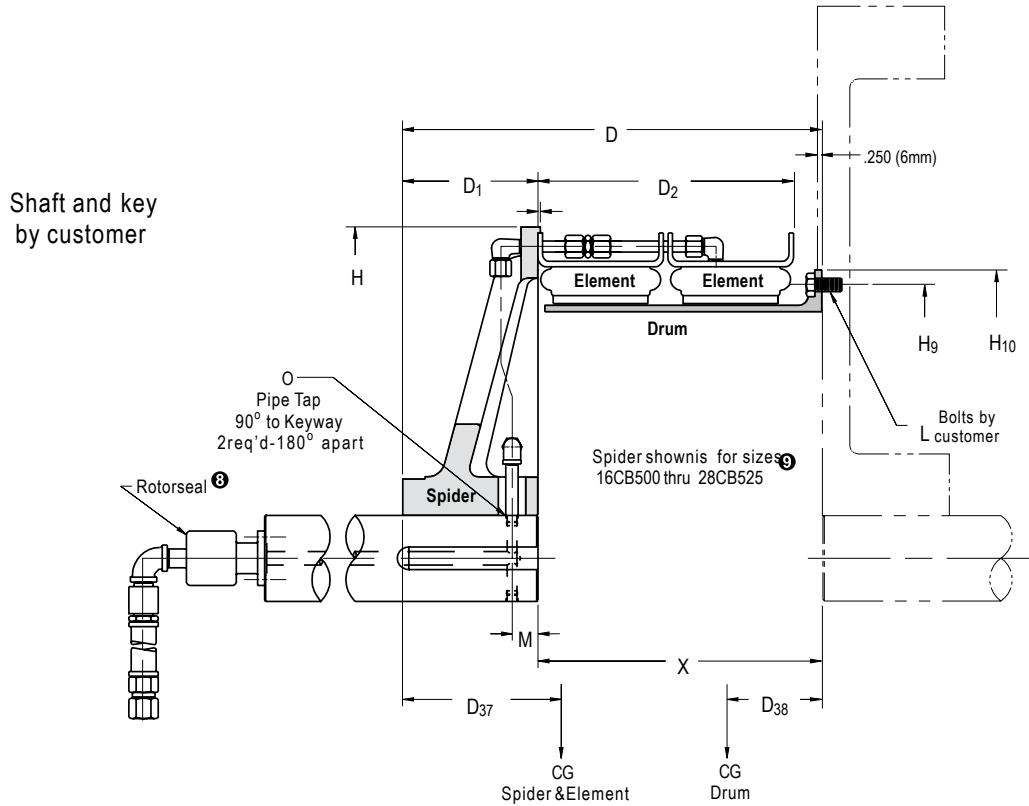

English	lb · in @ 75 psi	lb Ⓟ	Dimensions in inches																		
12CB350	105500	26600	C2	204	1.50	2.63	16.63	4.00	10.13	6.2	4.4	18.00	17.250	18.375	8	0.50	1.50	⑤	⑦	12.63	
14CB400	105501	39400	C2	228	2.00	3.56	17.91	4.34	11.13	7.4	3.6	20.00	21.375	22.500	6	0.63	1.75	⑤	⑦		
16CB500	105502	70400	C2	479 ^{13.56}	2.00	4.13	20.50	5.50	13.63	8.0	4.6	24.00	25.250	26.500	12	0.63	1.75		1.44	3/8-18	
18CB500	105503	88000	C2	519 ^{15.00}	2.25	4.38	22.19	5.50	13.63	8.1	5.8	26.00	25.250	26.500	12	0.63	1.75		1.44	3/8-18	
20CB500	105504	107200	C2	554 ^{16.69}	2.50	3.81	22.19	5.50	13.63	7.7	5.6	28.00	25.250	26.500	12	0.63	2.00		1.44	3/8-18	
22CB500	105505	124600	C2	607 ^{16.69}	2.75	4.50	22.69	6.00	13.63	7.9	6.2	30.00	25.250	26.500	12	0.63	2.00		1.44	3/8-18	
24CB500	105506	150000	C2	674 ^{16.69}	2.75	4.50	23.19	6.50	13.63	8.1	6.1	32.00	27.250	28.875	12	0.75	2.25		1.44	3/8-18	16.69
26CB525	105507	184800	3/4	804	2.75	4.50	24.19	6.50	14.25	8.7	6.6	34.63	29.250	30.750	12	0.75	2.25		1.44	3/8-18	17.69
28CB525	105508	212000	3/4	863	2.75	3.81	25.19	7.50	14.44	9.3	6.9	36.63	30.250	31.875	12	0.75	2.25		1.44	3/8-18	17.69

Size	Part No.	Rating	Size	Mass	Spider Bore D		D ₁	D ₂	D ₃₇	D ₃₈	H	H ₉	H ₁₀	L (Bolt)	M	O	X			
					Min.	Max.														
12CB350	105500	3010	C2	92	38	67	422	102	257	157	112	457	438,2	466,7	8	13		⑤	⑦	321
14CB400	105501	4450	C2	103	51	90 ³⁸	455	110	283	188	91	508	542,9	571,5	6	16		⑤	⑦	344
16CB500	105502	7960	C2	217	51	105	521	140	346	203	117	610	641,4	673,1	12	16		37	3/8-18	381
18CB500	105503	9940	C2	235	57	111	564	140	346	206	147	660	641,4	673,1	12	16		37	3/8-18	424
20CB500	105504	12100	C2	251	64	97	564	140	346	196	142	711	641,4	673,1	12	16		37	3/8-18	424
22CB500	105505	14100	C2	275	70	114	576	152	346	201	157	762	641,4	673,1	12	16		37	3/8-18	424
24CB500	105506	17000	C2	305	70	114	589	165	346	206	155	813	692,2	733,4	12	19		37	3/8-18	424
26CB525	105507	20900	3/4	364	70	114	614	165	362	221	168	879	743,0	781,1	12	19		37	3/8-18	449
28CB525	105508	24000	3/4	391	70	97	640	191	367	236	175	930	768,4	809,6	12	19		37	3/8-18	449

SI	N · m @ 5,2 bar	kg	Dimensions in millimeters																
----	--------------------	----	---------------------------	--	--	--	--	--	--	--	--	--	--	--	--	--	--	--	--

Airflex®CB Clutch Application

Form CB-409 — Air Bridge Arrangement —

Technical Data — Sizes 12 to 45

Section B

Size	Part Numbers			
	Element Assembly	Drum	Drum Hub	Air Bridge
12CB350	142098KH	407049	406903	411807
14CB400	142087KH	407051	406905	401546
16CB500	142211KT	407053	406907	408165
18CB500	142264KT	408285	406909	407294
20CB500	142265KT	407055	406911	407296
22CB500	142266KT	408287	406913	407307
24CB500	142267KT	407057	406915	12038

Size	Part Numbers			
	Element Assembly	Drum	Drum Hub	Air Bridge
26CB525	142268KT	408289	406917	411796
28CB525	142269KT	407059	406919	400878
30CB525	142270KT	408343	406921	400203
32CB525	142271KT	407061	406923	400764
36CB525	142272KT	407063	406925	400410
40CB525	142273KT	407065	406927	411797
45CB525	142081KT	407067	406929	411798

Size	English Units								⑥
	Element Ass'y		Drum		Drum Hub		Air Bridge		
	Weight lb	Wk ² lb · ft ²	Weight lb	Wk ² lb · ft ²	Weight lb	Wk ² lb · ft ²	Weight lb	Wk ² lb · ft ²	
12CB350	30	12	30	5.9	22	0.8	2	0.2	
14CB400	35	21	38	10.5	54	3.2	2	0.3	
16CB500	74	52	50	19	74	6.6	6	1.3	
18CB500	81	70	67	31	83	9	14	10.3	
20CB500	88	90	72	43	97	16	15	12.5	
22CB500	95	114	79	58	133	25	15	16	
24CB500	102	142	93	80	142	33	19	22	
26CB525	133	210	108	110	164	43	19	25	
28CB525	140	252	117	140	172	55	19	29	
30CB525	148	303	140	192	213	69	20	32	
32CB525	157	359	160	252	234	97	19	32	
36CB525	178	510	160	319	319	157	19	42	
40CB525	201	730	209	523	344	214	23	56	
45CB525	262	1115	237	758	491	379	24	66	

Size	SI Units								⑥
	Element Ass'y		Drum		Drum Hub		Air Bridge		
	Mass J kg	Mass J kg · m ²	Mass J kg	Mass J kg · m ²	Mass J kg	Mass J kg · m ²	Mass J kg	Mass J kg · m ²	
12CB350	14	0,50	14	0,25	10,0	0,03	0,9	0,01	
14CB400	16	0,88	17	0,44	24	0,13	0,9	0,01	
16CB500	34	2,18	23	0,80	34	0,28	2,7	0,05	
18CB500	37	2,94	30	1,30	38	0,38	6,3	0,43	
20CB500	40	3,78	33	1,81	44	0,67	6,8	0,53	
22CB500	43	4,79	36	2,44	60	1,05	6,8	0,67	
24CB500	46	5,96	42	3,36	64	1,39	8,6	0,92	
26CB525	60	8,82	49	4,62	74	1,81	8,6	1,05	
28CB525	63	10,58	53	5,88	78	2,31	8,6	1,22	
30CB525	67	12,73	63	8,06	96	2,90	9,1	1,34	
32CB525	71	15,08	72	10,58	106	4,07	8,6	1,34	
36CB525	81	21,42	72	13,40	145	6,59	8,6	1,76	
40CB525	91	30,66	95	21,97	156	8,99	10	2,35	
45CB525	119	46,83	107	31,84	222	15,92	11	2,77	

Notes:

- ① Refers to basic part number only and does not include the rotorseal and hose. Element sizes 12 and 14 have two air inlets. All other sizes have either two or four air inlets.
- ② Dynamic torque shown, static torque approximately 25% greater. Torque in each application is dependent upon air pressure and speed.
- ③ Based upon minimum bores. Rotorseal and hose not included.
- ④ Tolerance for sizes:
 12 thru 24, 28 and 32
 +0.000/-0.005 in (+0,00/-0,13 mm)
 26 and 30
 +0.000/-0.008 in (+0,00/-0,20 mm)
 36 thru 45
 +0.000/-0.010 in (+0,00/-0,25 mm)

- ⑤ Refer to Rotorseal Section for mounting and dimension information.
- ⑥ Based upon minimum bores.

Airflex® CB Clutch Application

Form CB-409 — Air Bridge Arrangement —

Dimensional Data — Sizes 12 to 45

Section B

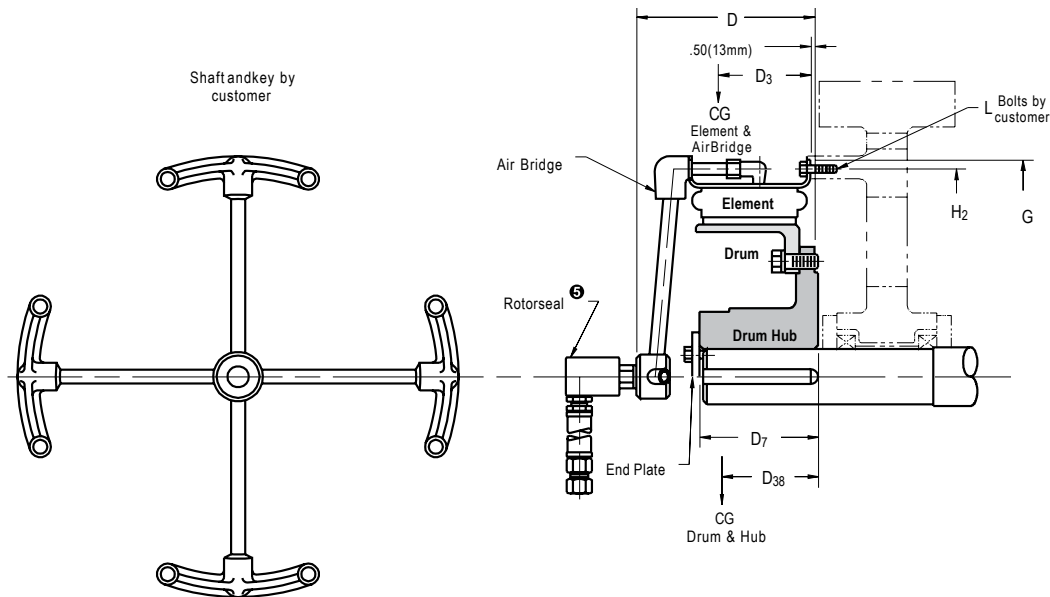

English		lb · in @75psi		lb [Ⓞ]	Dimensions in inches									
12CB350	104420	13300	B3	84	1.50	3.31	7.75	3.25	2.7	2.2	17.625	16.875	14	0.375
14CB400	104421	19700	B3	129	2.00	4.25	8.38	5.00	2.9	3.3	19.625	18.875	16	0.375
16CB500	104422	35200	C2	204	2.00	4.88	9.25	5.75	3.7	3.8	23.500	22.500	8	0.500
18CB500	104423	44000	C2	245	2.25	5.00	9.31	5.75	4.0	4.0	25.500	24.375	12	0.500
20CB500	104424	53600	C2	272	2.50	5.00	9.38	5.75	3.9	4.1	27.500	26.375	12	0.500
22CB500	104425	62300	C2	322	2.75	5.69	9.44	6.50	3.9	4.6	29.500	28.375	12	0.500
24CB500	104426	75000	C2	356	2.75	5.69	9.50	6.50	4.0	4.8	31.500	30.375	16	0.500
26CB525	104427	92400	C2	424	2.75	5.69	10.06	6.50	4.0	4.7	34.000	32.750	16	0.625
28CB525	104428	106000	C2	448	2.75	5.69	10.13	6.50	4.0	4.8	36.000	34.750	16	0.625
30CB525	104429	121000	C2	521	3.00	6.31	10.20	8.00	4.0	5.9	38.000	36.750	16	0.625
32CB525	104430	137000	C2	570	3.00	6.06	10.06	8.00	4.0	6.0	40.000	38.750	18	0.625
36CB525	104431	172000	C2	676	4.00	7.00	10.25	9.00	3.9	6.7	44.625	43.125	18	0.750
40CB525	104432	211000	3/4 RH	777	4.00	7.00	10.50	9.00	4.0	6.8	48.625	47.125	20	0.750
45CB525	104433	260000	3/4 RH	1014	4.38	9.88	10.69	10.00	3.9	7.2	53.625	52.125	24	0.750

Size	Part [Ⓞ] Number	M _r [Ⓞ] Torque Rating	Rotorseal Size	Weight		Dimensions in inches									
				Mass	Hub Bore		D	D ₃₇	D ₃₈	G	H ₂	L (Bolt)			
					Min.	Max.						No.	Dia.		
12CB350	104420	1500	B3	38	38	84	197	83	69	56	447,7	428,6	14	10	
14CB400	104421	2230	B3	58	51	108	213	127	74	84	498,5	479,4	16	10	
16CB500	104422	3980	C2	92	51	124	235	146	94	97	596,9	571,5	8	13	
18CB500	104423	4970	C2	111	57	127	237	146	102	102	647,7	619,1	12	13	
20CB500	104424	6060	C2	123	64	127	238	146	99	104	698,5	669,9	12	13	
22CB500	104425	7040	C2	146	70	144	240	165	99	117	749,3	720,7	12	13	
24CB500	104426	8480	C2	161	70	144	241	165	102	122	800,1	771,5	16	13	
26CB525	104427	10400	C2	192	70	144	256	165	102	119	863,6	831,9	16	16	
28CB525	104428	12000	C2	203	70	144	257	165	102	122	914,4	882,7	16	16	
30CB525	104429	13700	C2	236	76	160	259	203	102	150	965,2	933,5	16	16	
32CB525	104430	15500	C2	258	76	154	256	203	102	152	1016,0	984,3	18	16	
36CB525	104431	19400	C2	306	102	178	260	229	99	170	1133,5	1095,4	18	19	
40CB525	104432	23800	3/4 RH	352	102	178	267	229	102	173	1235,1	1197,0	20	19	
45CB525	104433	29400	3/4 RH	459	111	251	271	254	99	183	1362,1	1324,0	24	19	

SI		N·m @ 5,2 bar		kg	Dimensions in millimeters									
----	--	------------------	--	----	---------------------------	--	--	--	--	--	--	--	--	--

Airflex® CB Clutch and Brake Application

Form CB-429 — Gap Mounted Arrangement —

Technical Data — Sizes 12 to 45

Section B

Size	Part Numbers					Size	Part Numbers				
	Clutch® Element	Brake® Element	Spider	Drum	Hub		Clutch® Element	Brake® Element	Spider	Drum	Hub
12CB350	142098JG	142098JA	408374	411860	406902	26CB525	142268KP	142268KY	408281	411867	406916
14CB400	142087JG	142087JA	408376	411861	406904	26CB525	142269KP	142269KY	408282	411868	406918
16CB500	142211KP	142211KY	408276	411862	406906	30CB525	142270KP	142270KY	407096	411869	406920
18CB500	142264KP	142264KY	408277	411863	406908	32CB525	142271KP	142271KY	407097	411870	406922
20CB500	142265KP	142265KY	408278	411864	406910	36CB525	142272KP	142272KY	407098	411871	406924
22CB500	142266KP	142266KY	408279	411865	406912	40CB525	142273KP	142273KY	407099	411872	406926
24CB500	142267KP	142267KY	408280	411866	406914	45CB525	142443KP	142443KY	502369	411873	406928

English	lb	lb · ft ²	lb	lb · ft ²	lb	lb · ft ²	lb	lb · ft ²
12CB350	30	12	46	8.1	61	13	22	0.8
14CB400	35	21	50	11.2	83	24	54	3.2
16CB500	74	52	146	53	109	43	74	6.6
18CB500	81	70	152	63	126	63	83	9
20CB500	88	90	183	91	139	87	97	16
22CB500	95	114	227	123	152	117	133	25
24CB500	102	142	257	150	173	156	142	33
26CB525	133	210	298	220	198	211	164	43
28CB525	140	252	337	270	216	268	172	55
30CB525	148	303	341	390	237	337	213	69
32CB525	157	359	392	453	254	413	234	97
36CB525	178	510	505	710	287	597	319	157
40CB525	201	730	464	774	327	840	344	214
45CB525	262	1115	1294	1887	369	1212	491	379

Size ®	Weight		Wk ²		Weight		Wk ²	
	Element (each)		Spider		Drum		Hub	
	Mass	J	Mass	J	Mass	J	Mass	J
12CB350	14	0,50	21	0,34	28	0,55	10	0,03
14CB400	16	0,88	23	0,47	38	1,01	25	0,13
16CB500	34	2,18	66	2,23	49	1,81	34	0,28
18CB500	37	2,94	69	2,65	57	2,65	38	0,38
20CB500	40	3,78	83	3,82	63	3,65	44	0,67
22CB500	43	4,79	103	5,17	69	4,91	60	1,05
24CB500	46	5,96	117	6,30	79	6,55	64	1,39
26CB525	60	8,82	135	9,24	90	8,86	74	1,81
28CB525	64	10,58	153	11,34	98	11,26	78	2,31
30CB525	67	12,73	155	16,38	108	14,15	97	2,90
32CB525	71	15,08	178	19,03	115	17,35	106	4,07
36CB525	81	21,42	229	29,82	130	25,07	145	6,59
40CB525	91	30,66	211	32,51	148	35,28	156	8,99
45CB525	119	46,83	587	79,25	168	50,90	223	15,92

SI ®	kg	kg · m ²	kg	kg · m ²	kg	kg · m ²	kg	kg · m ²
------	----	---------------------	----	---------------------	----	---------------------	----	---------------------

- Notes:**
- ❶ Dynamic torque shown, static torque approximately 25% greater. Torque in each application is dependent upon air pressure and speed.
 - ❷ Based upon minimum bores. Rotorseal and hose not included.
 - ❸ M (in)=0.268 (H/2-radius of bore) + 0.34
 M (mm)=0,268 (H/2-radius of bore) + 8,7
 - ❹ American National Pipe Thread
 - ❺ Pipe tap not required. Thru hole diameter 0.44 in (11 mm).
 - ❻ Refer to Rotorseal Section for mounting and dimension information.
 - ❼ Refer to CB Spider Piping and Configuration catalog page for other sizes.
 - ❽ Element sizes 12 and 14 have two inlets. All other sizes have four air inlets.
 - ❾ Part number shown for element with one air inlet.
 - ❿ Based upon minimum bores.

Airflex® CB Clutch and Brake Application

Form CB-429 — Gap Mounted Arrangement —

Dimensional Data — Sizes 12 to 45

Section B

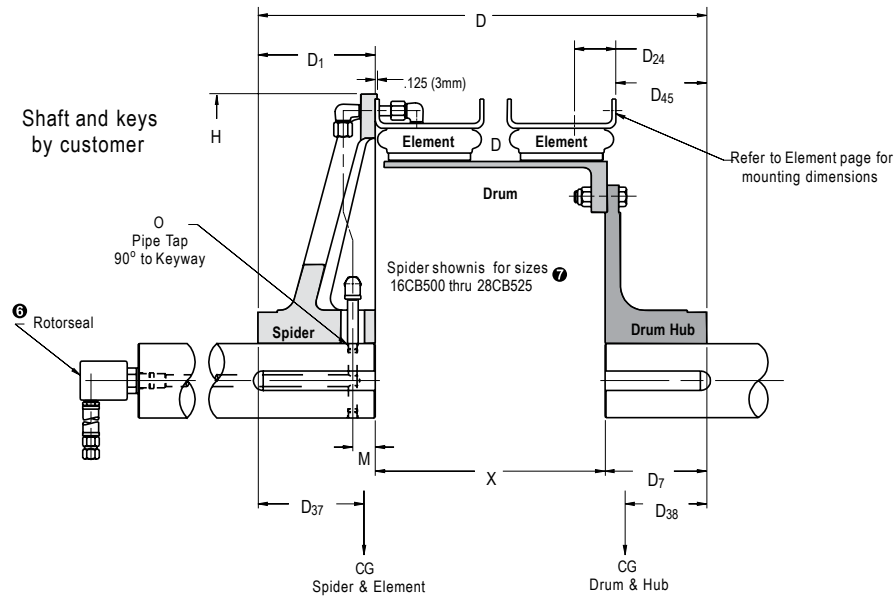

English	lb · in @75psi	lbØ	Dimensions in inches										Ø	Ø	X	
12CB350	13300	B2	187	1.50	2.63	17.75	4.00	3.25	2.00	3.20	5.80	2.812	18.00	Ø	Ø	10.50
14CB400	19700	B2	262	2.00	3.56	20.84	4.34	5.00	2.00	3.40	6.70	4.562	20.00	Ø	Ø	11.50
16CB500	35200	C2	480	2.00	4.13	25.25	5.50	5.75	2.50	5.20	8.00	5.187	24.00	1.44	3/8-18	14.00
18CB500	44000	C2	527	2.25	4.38	25.25	5.50	5.75	2.50	5.30	8.00	5.187	26.00	1.44	3/8-18	14.00
20CB500	53600	C2	599	2.50	3.81	25.25	5.50	5.75	2.50	5.30	8.10	5.187	28.00	1.44	3/8-18	14.00
22CB500	62300	C2	706	2.75	4.50	26.50	6.00	6.50	2.50	5.40	8.30	5.937	30.00	1.44	3/8-18	14.00
24CB500	75000	C2	781	2.75	4.50	27.00	6.50	6.50	2.50	5.60	8.30	5.937	32.00	1.44	3/8-18	14.00
26CB525	92400	C2	932	2.75	4.50	27.63	6.50	6.50	2.50	5.90	8.40	5.906	34.63	1.44	3/8-18	14.63
28CB525	106000	C2	1011	2.75	3.81	28.75	7.50	6.50	2.50	6.60	8.70	5.906	36.63	1.44	3/8-18	14.75
30CB525	121000	C2	1093	3.00	4.50	30.25	7.50	8.00	2.50	6.80	9.50	7.406	38.63	1.44	3/8-18	14.75
32CB525	137000	C2	1201	3.00	4.00	30.25	7.50	8.00	2.50	6.60	9.70	7.406	40.63	1.44	3/8-18	14.75
36CB525	172000	C2	1477	4.00	5.75	32.25	8.50	9.00	2.75	7.10	9.90	8.406	45.25	1.44	1/2-14	14.75
40CB525	211000	3/4 RH	1548	4.00	4.88	32.25	8.50	9.00	2.75	7.60	10.10	8.406	49.25	1.44	1/2-14	14.75
45CB525	260000	3/4 RH	2691	4.38	8.00	35.75	11.00	10.00	2.75	8.80	10.10	9.406	54.25	6.00	1/2-14	14.75

Size	M ^Ø Torque Rating	Rotorseal Size	Weight		Bore Range	D	D ₁	D ₇	D ₂₄	D ₃₇	D ₃₈	D ₄₅	H ₂	M	Ø	Ø	X
			Mass														
			Min.	Max.													
12CB350	1500	B2	85	38	67	451	102	83	51	81	147	71,4	457	Ø	Ø		267
14CB400	2230	B2	119	51	90	529	110	127	51	86	170	115,9	508	Ø	Ø		292
16CB500	3980	C2	217	51	105	641	140	146	64	132	203	131,7	610	37	3/8-18		356
18CB500	4970	C2	239	57	111	641	140	146	64	135	203	131,7	660	37	3/8-18		356
20CB500	6060	C2	271	64	97	641	140	146	64	135	206	131,7	711	37	3/8-18		356
22CB500	7040	C2	320	70	114	673	152	165	64	137	211	150,8	762	37	3/8-18		356
24CB500	8480	C2	354	70	114	686	165	165	64	142	211	150,8	813	37	3/8-18		356
26CB525	10400	C2	422	70	114	702	165	165	64	150	213	150,0	880	37	3/8-18		372
28CB525	12000	C2	458	70	97	730	191	165	64	168	221	150,0	930	37	3/8-18		375
30CB525	13700	C2	495	76	114	768	191	203	64	173	241	188,1	981	37	3/8-18		375
32CB525	15500	C2	544	76	102	768	191	203	64	168	246	188,1	1032	37	3/8-18		375
36CB525	19400	C2	669	102	146	819	216	229	70	180	251	213,5	1149	37	1/2-14		375
40CB525	23800	3/4 RH	701	102	124	819	216	229	70	193	257	213,5	1251	37	1/2-14		375
45CB525	29400	3/4 RH	1219	111	203	908	279	254	70	224	257	238,9	1378	152	1/2-14		375

SI	N · m @ 5,2 bar	Ø kg	Dimensions in millimeters														
----	--------------------	---------	---------------------------	--	--	--	--	--	--	--	--	--	--	--	--	--	--

Airflex®CB Clutch Application

Form PCB-201 — Sheave Clutch Arrangement —
 Component Part Numbers — Sizes 4 to 10
 Section B

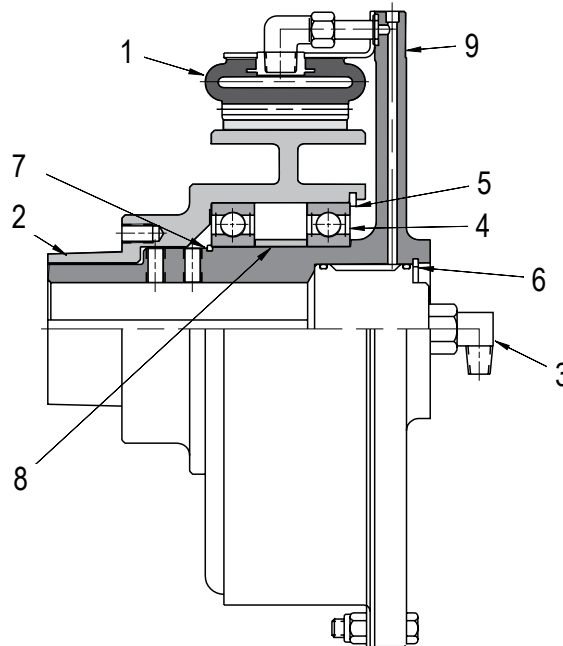

Part Numbers for Complete Applications and Spiders -Item 9

4CB200			6CB200			8CB250			10CB300		
Bore in	Application	Spider	Bore in	Application	Spider	Bore in	Application	Spider	Bore in	Application	Spider
0.875	145987F	407884-02	1.125	145866Q	506516-01	1.625	145873W	506513-01		145874AC	506514-01
1.000	145987H	407884-04	1.375	145866R	506516-02	1.875	145873X	506513-02	2.125	145874AD	506514-02
1.125	145987G	407884-03	1.625	145866S	506516-03				2.375	145874AE	506514-03

Size	1 Element	2 Drum	3 Rotorseal	4 Bearing	5 Retainer	6 Retainer	7 Retainer	8 Spacer
4CB200	142840JB	410175	145631L	159x78	138x16	138x19	139x6	202737
6CB200	142095JG	407926	145106BM	159x40	138x15	138x56	139x16	202756
8CB250	142096JG	505112	145106BL	159x154	138x58	138x27	136x43	202787
10CB300	142197JG	505196	145107BA	⑥	138x5		⑦	⑧

- Notes:**
- ① Available only for bores shown. Tolerance for bores:
 thru 2.000 +0.0016/-0.000 in
 2.125 and 2.375 +0.0018/-0.000 in
 Square key for bores thru 2.125 in.
 Rectangular key for 2.375 in. bore.
 - ② Tolerance +0.000/-0.002 in (+0.00/-0.05 mm).
 - ③ American National Standard for Unified Screw Threads.
 Bolts and lockwashers furnished with clutch.
 - ④ American National Pipe Thread
 - ⑤ Dynamic torque shown, static torque approximately 25% greater. Torque in each application is dependent upon air pressure and speed.
 - ⑥ Two different size bearings used:
 Bearing adjacent to rotorseal - 159x157
 Bearing adjacent to taper - 159x154
 - ⑦ For bearing adjacent to rotorseal - 139x2 For bearing adjacent to taper - 139x45
 - ⑧ Not required. Bearings held by retainers.

Airflex® CB Clutch Application

Form PCB-201 — Sheave Clutch Arrangement —
 Dimensional and Technical Data — Sizes 4 to 10
 Section B

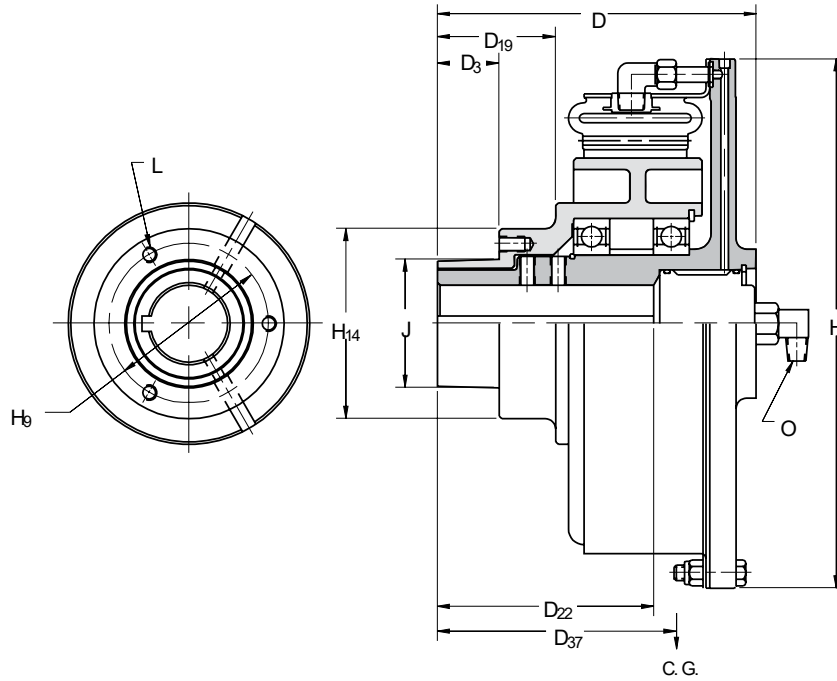

English	lb · in @75 psi	rpm	lb	lb · ft ²	
4CB200	1000	1800	14	0.4	0.1
6CB200	2040	1800	33	1.7	0.4
8CB250	4290	1800	55	3.9	1.2
10CB300	8150	1800	96	10	3.2

Size	Mr Torque Rating	Maximum Speed	Weight			
			Mass	Wk ²	Wk ²	
					Element and Spider	Drum
					J	J
4CB200	113	1800	6,3	0,02	0,0042	
6CB200	231	1800	15	0,07	0,02	
8CB250	485	1800	25	0,16	0,05	
10CB300	921	1800	43	0,42	0,13	
SI	N · m @5, 2 bar	rpm	kg	kg · m ²		

English	Dimensions in inches												
4CB200	0.875-1.000-1.125	5.19	1.56	3.00	0.94	3.06	7.31	2.683	3.13	2.188	SD	1/4-20	1/8-27
6CB200	1.125-1.375-1.625	6.69	2.75	4.50	1.38	4.31	10.75	3.312	3.88	2.813	SK	5/16-18	1/4-18
8CB250	1.625-1.875	7.75	2.88	5.41	1.50	4.97	12.88	3.875	4.63	3.126	SF	3/8-16	1/4-18
10CB300	1.875-2.125-2.375	9.75	4.50	7.13	1.88	6.44	15.38	5.000	6.00	3.836	E	1/2-13	1/2-14
Size	Bores Ø Available	D	D ₁₉	D ₂₂	D ₃₀	D ₃₇	H	H ₉	H ₁₄	J Ø	Ø L	Ø O	
											Dia. Lg End	Fits QD Hub	
4CB200	0.875-1.000-1.125	132	40	76	24	78	186	68,1	80	55,6	SD	1/4-20	1/8-27
6CB200	1.125-1.375-1.625	170	70	114	35	109	273	84,1	99	71,5	SK	5/16-18	1/4-18
8CB250	1.625-1.875	197	73	137	38	126	327	98,4	118	79,4	SF	3/8-16	1/4-18
10CB300	1.875-2.125-2.375	248	114	181	48	164	391	127,0	152	97,4	E	1/2-13	1/2-14
SI	inches	Dimensions in millimeters											

Airflex® CB Clutch Application

Form PCB-203 — Bearing Mounted Arrangement —
Component Part Numbers — Sizes 6 to 14
Section B

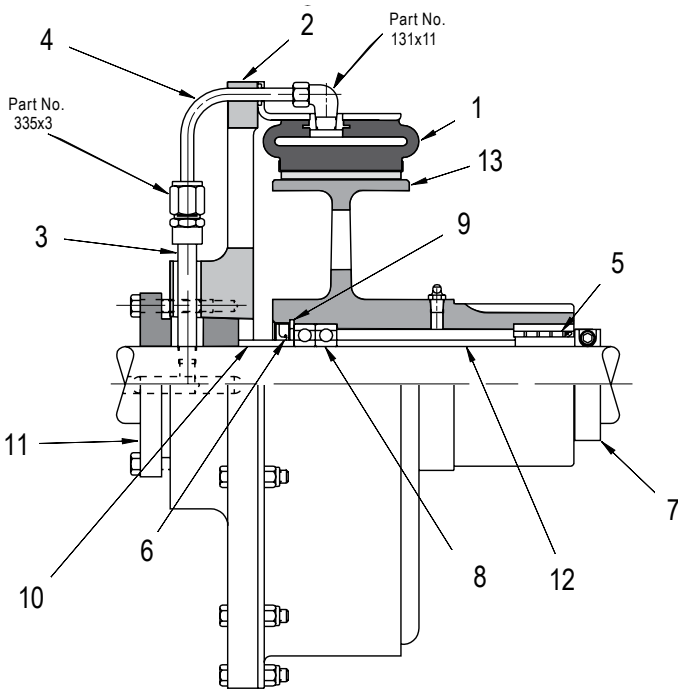

Shaft Dia (in)	5 Needle Bearing	6 Oil Seal	7 Safety Collar	8 Ball Bearing	9 Retainer Ring
1.250	160x43	113x95	149x198	159x135	138x29
1.375	160x44	113x267	149x200	159x136	138x30
1.500	160x45	113x268	149x202	159x134	138x27
1.625	160x46	113x269	149x204	159x137	138x31
1.750	160x47	113x270	149x206	159x138	138x32
1.875	160x48	113x271	149x208	159x139	138x16
2.000	160x49	113x259	149x210	159x132	138x26
2.250	160x51	113x273	149x213	159x141	138x34
2.375	160x52	113x85	149x214	159x142	138x22
2.500	160x53	113x276	149x216	159x143	138x21

Size	1 Element	2 Spider	3 Pipe Nipple	4 AirTube
6CB200	142095JC	405307	⊕	201641
8CB250	142096JC	405308	70x135	201640
10CB300	142197JC	405309	70x121	201598
12CB350	142098JC	405310	70x212	201654
14CB400	142087JC	405311	70x121	201605

Shaft Diameter in	6CB200 & 8CB250		6CB200		8CB250	
	10 Spacer	11 Bushing	12 Spacer	13 Drum	12 Spacer	13 Drum
1.250	305137-01	304040-01	305136-22	406566-01	305136-29	406571-01
1.375	305137-02	304040-03	305136-23	406566-02	305136-30	406571-02
1.500	305137-03	304040-05	305136-24	406566-03	305136-31	406571-03
1.625	305137-04	304040-07	305136-25	406566-04	305136-32	406571-04
1.750	305137-05	304040-09	305136-26	406566-05	305136-33	406571-05
1.875	305137-06	304040-11	305136-27	406566-06	305136-34	406571-06
2.000	305137-07	304040-13	305136-28	406566-07	305136-35	406571-07

Shaft Diameter in	10CB300 thru 14CB400		10CB300		12CB350		14CB400	
	10 Spacer	11 Bushing	12 Spacer	13 Drum	12 Spacer	13 Drum	12 Spacer	13 Drum
1.750	305137-08	304042-01	305136-08	405141-01	305136-01	405142-01	305136-15	405143-01
1.875	305137-09	304042-03	305136-09	405141-02	305136-02	405142-02	305136-16	405143-02
2.000	305137-10	304042-05	305136-10	405141-03	305136-03	405142-03	305136-17	405143-03
2.250	305137-12	304042-09	305136-12	405141-05	305136-05	405142-05	305136-19	405143-05
2.375	305137-13	304042-11	305136-13	405141-06	305136-06	405142-06	305136-20	405143-06
2.500	305137-14	304042-13	305136-14	405141-07	305136-07	405142-07	305136-21	405143-07

Airflex®CB Clutch Application

Form PCB-203 — Bearing Mounted Arrangement —

Dimensional and Technical Data — Sizes 6 to 14

Section B

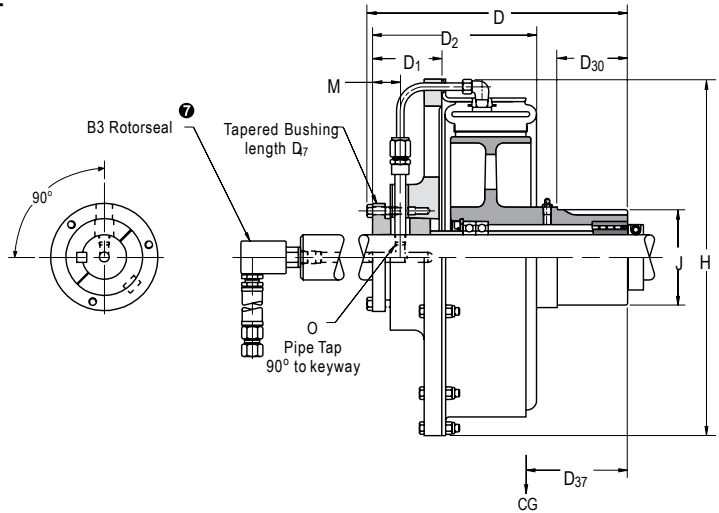

English		lb · in @ 75 psi	Dimensions in inches										
6CB200	105782	2040	1.250 thru 2.000	10.75	2.69	6.69	3.25	0.54	6.08	2.50	10.75	4.252	1.38
8CB250	105783	4290	1.250 thru 2.000	11.25	2.69	7.19	3.25	0.54	6.48	2.50	12.88	4.252	1.38
10CB300	105784	8150	1.750 thru 2.500	13.06	3.44	8.56	3.50	0.73	7.76	2.88	15.38	4.752	1.38
12CB350	105785	13300	1.750 thru 2.500	13.69	3.44	9.19	3.50	0.73	8.28	2.88	17.63	4.752	1.38
14CB400	105786	19700	1.750 thru 2.500	14.19	3.44	9.69	3.50	0.73	8.69	2.88	19.63	4.752	1.38

Size	Part ^① Number	M, ^② Torque Rating	Available for ^③ Shaft Diameters of:	D	D ₁	D ₂	D ₃₀	D ₃₃	D ₃₇	D ₄₇	H	J	M
6CB200	105782	231	1.250 thru 2.000	273	68	170	83	14	154	64	273	108,0	35
8CB250	105783	485	1.250 thru 2.000	286	68	183	83	14	165	64	327	108,0	35
10CB300	105784	921	1.750 thru 2.500	332	87	217	89	19	197	73	391	120,7	35
12CB350	105785	1500	1.750 thru 2.500	348	87	233	89	19	210	73	448	120,7	35
14CB400	105786	2230	1.750 thru 2.500	360	87	246	89	19	221	73	499	120,7	35

SI		N · m @ 5, 2 bar	Dimensions in millimeters										
----	--	---------------------	---------------------------	--	--	--	--	--	--	--	--	--	--

English	lb Ⓞ	lb · ft ^② Ⓞ		Shaft Dia. in	rpm max ^④	Shaft Dia. in	rpm max ^④
6CB200	42	2.0	0.6	1.250	1800	1.875	1350
8CB250	51	4.1	1.0	1.375	1700	2.000	1200
10CB300	88	12	2.6	1.500	1700	2.250	1100
12CB350	120	22	4.9	1.625	1500	2.375	1000
14CB400	137	32	9.1	1.750	1350	2.500	1000

Size	Mass	Wk ²	Element & Spider	Drum
			J	
6CB200	19	0,08		0,03
8CB250	23	0,17		0,04
10CB300	40	0,50		0,11
12CB350	54	0,92		0,21
14CB400	62	1,34		0,38
SI	kgⓄ			kg · m ² Ⓞ

Notes:

- ① Refers to basic part number only and does not include the rotor seal and hose. When ordering, specify shaft diameter.
- ② Dynamic torque shown, static torque approximately 25% greater. Torque in each application is dependent upon air pressure and speed.
- ③ Available only for inch series shafting in 0.125 increments. Use standard square keys.
- ④ Tolerance +/-0.0005 in (+/-0,01 mm)
- ⑤ Based upon minimum bores.
- ⑥ Based on needle bearing limitation.
- ⑦ Refer to Rotorseal Section for mounting and dimension information.
- ⑧ Part numbers for shaft diameters:
1.250 thru 1.500 in - 70x135
All other diameters - 70x45

Airflex® CB Clutch and Brake Applications

Forms 204, 205, 206, & 208 — Tapered Bushing Arrangements —

Dimensional Data — Sizes 4 to 14

Section B

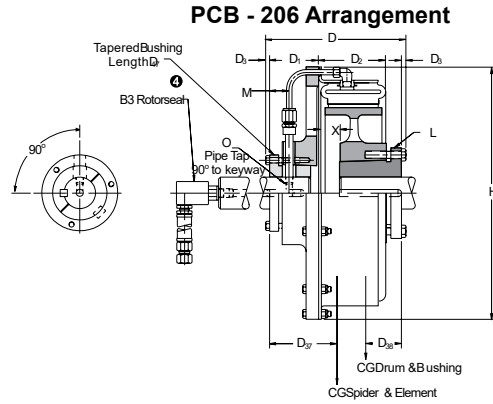
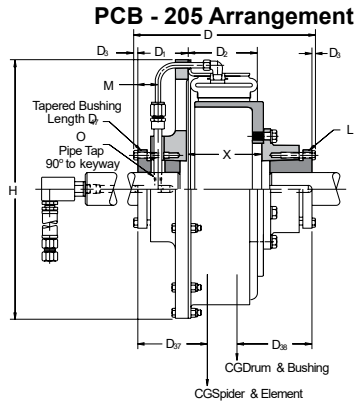

English	Dimensions in inches											
4CB200	0.875 thru 1.437	0.875 thru 1.437						103474	4.89	2.0	1.2	0.56
6CB200	1.250 thru 2.000	1.250 thru 2.000	103433	9.13	2.0	2.2	3.56	103475	6.88	2.0	1.4	0.44
8CB250	1.250 thru 2.000	1.250 thru 2.000	103434	9.63	2.4	2.7	4.06	103476	6.88	2.7	1.7	1.31
10CB300	1.750 thru 2.500	1.750 thru 2.500	103435	11.81	3.2	3.2	5.50	103477	8.31	3.2	2.0	2.00
	1.750 thru 2.500	2.563 thru 3.125	103727	12.78	3.2	3.9	4.88	103737	9.28	3.2	2.5	1.38
	2.563 thru 3.125	2.563 thru 3.125	103445	13.75	3.2	3.9	4.25	103478	10.25	3.2	2.5	0.75
12CB350	1.750 thru 2.500	1.750 thru 2.500	103446	12.44	3.3	3.4	6.13	103479	8.94	3.2	1.3	2.63
	1.750 thru 2.500	2.563 thru 3.125	103729	13.41	3.3	3.9	5.50	103739	9.91	3.2	2.5	2.00
	2.563 thru 3.125	2.563 thru 3.125	103447	14.38	3.7	3.9	4.88	103480	10.88	3.2	2.5	1.38
14CB400	1.750 thru 2.500	1.750 thru 2.500	103730	13.41	3.3	3.4	5.50	103740	9.91	3.2	1.3	2.00
	1.750 thru 2.500	1.750 thru 2.500	103448	12.94	3.7	3.3	6.63	103499	9.44	3.7	2.0	3.13
	1.750 thru 2.500	2.563 thru 3.125	103731	13.91	3.7	4.1	6.00	103741	10.41	3.7	3.0	2.50
	2.563 thru 3.125	2.563 thru 3.125	103449	14.88	3.7	4.1	5.88	103482	11.38	3.7	3.0	1.88
	2.563 thru 3.125	1.750 thru 2.500	103732	13.91	3.7	3.3	6.00	103742	10.41	3.7	2.0	2.50

Size	Shaft Diameter		PCB-205 Arrangement				PCB-206 Arrangement					
	Spider	Hub	Part No.	D	D ₃₇	D ₃₈	X	Part No.	D	D ₃₇	D ₃₈	X
4CB200	0.875 thru 1.437	0.875 thru 1.437	103474	124	51	30	14					
6CB200	1.250 thru 2.000	1.250 thru 2.000	103433	232	51	56	90	103475	175	51	36	11
8CB250	1.250 thru 2.000	1.250 thru 2.000	103434	245	61	69	103	103476	175	61	43	33
10CB300	1.750 thru 2.500	1.750 thru 2.500	103435	300	81	81	140	103477	211	81	51	51
	1.750 thru 2.500	2.563 thru 3.125	103727	325	81	99	124	103737	236	81	64	35
	2.563 thru 3.125	2.563 thru 3.125	103445	349	81	99	108	103478	260	81	64	19
12CB350	1.750 thru 2.500	1.750 thru 2.500	103728	325	81	81	124	103738	236	81	51	35
	1.750 thru 2.500	1.750 thru 2.500	103446	316	84	86	156	103479	227	81	33	67
	1.750 thru 2.500	2.563 thru 3.125	103729	341	84	99	140	103739	252	81	64	51
14CB400	1.750 thru 2.500	2.563 thru 3.125	103447	365	94	99	124	103480	276	81	64	35
	1.750 thru 2.500	1.750 thru 2.500	103730	341	84	86	140	103740	252	94	33	51
	1.750 thru 2.500	1.750 thru 2.500	103448	329	94	84	168	103499	240	94	51	80
	1.750 thru 2.500	2.563 thru 3.125	103731	353	94	104	152	103741	264	94	76	64
	2.563 thru 3.125	2.563 thru 3.125	103449	378	94	104	149	103482	289	94	76	48
	2.563 thru 3.125	1.750 thru 2.500	103732	353	94	84	152	103742	264	94	51	64

SI inches Dimensions in millimeters

Shaft Diameter	D ₁	D ₃	D ₄₇	M
0.875 thru 1.437	2.06	0.20	1.94	1.13
1.250 thru 2.000	2.69	0.28	2.50	1.38
1.750 thru 2.500	3.44	0.28	2.88	1.38
2.563 thru 3.125	4.31	0.38	4.38	2.25

Shaft Diameter Ø	D ₁	D ₃	D ₄₇	M
0.875 thru 1.437	52	5	49	29
1.250 thru 2.000	68	7	64	35
1.750 thru 2.500	87	7	73	35
2.563 thru 3.125	109	10	111	57

English Dimensions in inches

SI Dimensions in inches

Airflex® CB Clutch and Brake Applications

Forms 204, 205, 206, & 208 — Tapered Bushing Arrangements —

Dimensional Data — Sizes 4 to 14

Section B

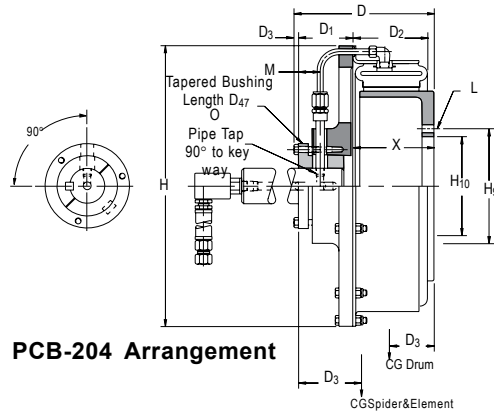

PCB-204 Arrangement

PCB - 208 Arrangement

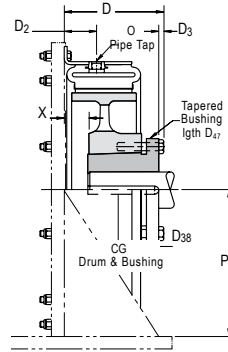

Dimensions in inches

English	lb · in @75psi	Dimensions in inches									
4CB200	1000	2.63	1.38	7.25					1/8-27	1/8-27	3.88
6CB200	2040	2.94	1.56	10.75	4.250	3.500	6	0.406	1/4-18	3/8-18	5.63
8CB250	4290	3.44	1.91	12.47	5.250	4.250	8	0.406	1/4-18	3/8-18	6.69
10CB300	8150	4.13	2.00	15.37	7.250	6.250	6	0.531	1/4-18	3/8-18	7.94
12CB350	13300	4.72	2.00	17.62	7.250	6.250	6	0.531	1/4-18	3/8-18	9.06
14CB400	19700	5.22	2.00	19.62	9.250	8.250	6	0.531	1/4-18	3/8-18	10.00

Size	Ø Torque Rating	D ₂	D ₂₄	H	H ₉	e H ₁₀	L (Bolt)	Ø O	Ø O ₄	P min.	
							Number	Size			
4CB200	113	67	35	184				1/8-27	1/8-27	99	
6CB200	231	75	40	273	108,0	88,9	6	10,3	1/4-18	3/8-18	143
8CB250	485	87	49	317	133,4	108,0	8	10,3	1/4-18	3/8-18	170
10CB300	921	105	51	390	184,2	158,8	6	13,5	1/4-18	3/8-18	202
12CB350	1500	120	51	448	184,2	158,8	6	13,5	1/4-18	3/8-18	230
14CB400	2230	133	51	498	235,0	209,6	6	13,5	1/4-18	3/8-18	254

SI **N·m @ 5,2 bar** **Dimensions in millimeters**

English	Dimensions in inches											
4CB200	0.875 thru 1.437				2.0				103502	2.63	1.2	0.44
6CB200	1.250 thru 2.000		103419	6.28	2.0	1.1	3.50	103503	3.41	1.4	0.63	
8CB250	1.250 thru 2.000		103420	6.78	2.4	1.1	4	103504	3.91	1.7	0.94	
10CB300	1.750 thru 2.500		103421	8.22	3.2	1.4	5.06	103505	4.59	2.0	1.44	
	2.563 thru 3.125		103422	9.19	4.0	1.4	4.44	103506	5.56	2.5	0.81	
12CB350	1.750 thru 2.500		103423	8.84	3.5	1.5	5.69	103507	5.22	1.3	2.06	
	2.563 thru 3.125		103424	9.81	4.1	1.5	5.06	103508	6.17	2.5	1.44	
14CB400	1.750 thru 2.500		103425	9.34	3.8	1.6	6.19	103509	5.72	2.0	2.56	
	2.563 thru 3.125		103426	10.31	4.4	1.6	5.56	103510	6.69	3.0	1.94	

Size	for Spider or Drum Ø	PCB-204 Assembly					PCB-208 Assembly			
	Shaft Diameter	Part No.	D	D ₃₇	D ₃₈	X	Part No.	D	D ₃₈	X
4CB200	0.875 thru 1.437			51			103502	67	30	11
6CB200	1.250 thru 2.000	103419	160	51	28	89	103503	87	36	16
8CB250	1.250 thru 2.000	103420	172	61	28	102	103504	99	43	24
10CB300	1.750 thru 2.500	103421	209	81	36	129	103505	117	51	37
	2.563 thru 3.125	103422	233	102	36	113	103506	141	64	21
12CB350	1.750 thru 2.500	103423	225	89	38	145	103507	133	33	52
	2.563 thru 3.125	103424	249	104	38	129	103508	157	64	37
14CB400	1.750 thru 2.500	103425	237	97	41	157	103509	145	51	65
	2.563 thru 3.125	103426	262	112	41	141	103510	170	76	49

SI **inches** **Dimensions in millimeters**

Notes appear on component parts page (p B-38).

Airflex® CB Clutch and Brake Applications

Forms 204, 205, 206, & 208 — Tapered Bushing Arrangements —

Component Part Numbers — Sizes 4 to 14

Section B

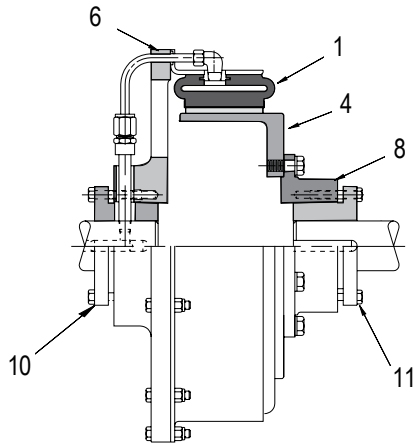

PCB-205 Arrangement

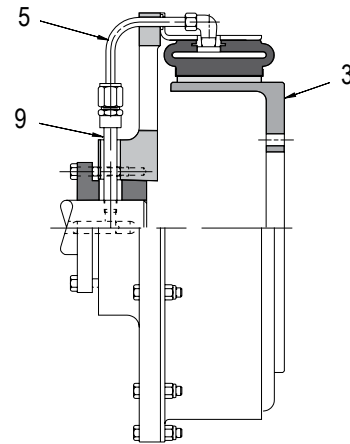

PCB - 204 Arrangement

Size	1	2	3	4	5
	Clutch Element	Brake Element	Drum w/thru holes	Drum w/tapped holes	Air Tube
4CB200	142840JD	142840JA			202735
6CB200	142095JC	142095JA	407043	407044	201641
8CB250	142096JC	142096JA	407045	407046	201640
10CB300	142197JC	142197JA	407047	407048	201598
12CB350	142098JC	142098JA	407049	407050	201654
14CB400	142087JC	142087JA	407051	407052	201605

Size	Shaft Diameter in	6	7	8	9
		Spider	Integral Drum	Drum Hub	Pipe Nipple
4CB200	0.875-1.125	407855	407854		70 x 185
	1.188-1.438	407855	407854		70 x 5
6CB200	1.250-2.000	405307	405325	405326	70 x 135
8CB250	1.250-2.000	405308	405341	405326	70 x 19
10CB300	1.750-2.500	405309	405342	405331	70 x 121
	2.563-3.125	405312	405343	405334	70 x 19
12CB350	1.750-2.500	405310	405344	405331	70 x 212
	2.563-3.125	405313	405345	405334	70 x 212
14CB400	1.750-2.500	405311	405346	405323	70 x 145
	2.563-3.125	405314	405347	405324	70 x 19

4CB200		
Shaft Diameter in	10 Bushing	11 Bushing
0.875	304038-1	304037-7
0.938	304038-2	304037-8
1.000	304038-3	304037-9
1.063	304038-4	304037-10
1.125	304038-5	304037-11
1.188	304038-6	304037-12
1.250	304038-7	304037-13
1.313	304038-8	304037-14
1.375	304038-9	304037-15
1.438	304038-10	304037-16

6CB200 & 8CB250		
Shaft Diameter in	10 Bushing	11 Bushing
1.250	304040-1	304039-9
1.313	304040-2	304039-10
1.375	304040-3	304039-11
1.438	304040-4	304039-12
1.500	304040-5	304039-13
1.563	304040-6	304039-14
1.625	304040-7	304039-15
1.688	304040-8	304039-16
1.750	304040-9	304039-17
1.813	304040-10	304039-18

Airflex® CB Clutch and Brake Applications

Forms 204, 205, 206, & 208 — Tapered Bushing Arrangements —

Component Part Numbers — Sizes 4 to 14

Section B

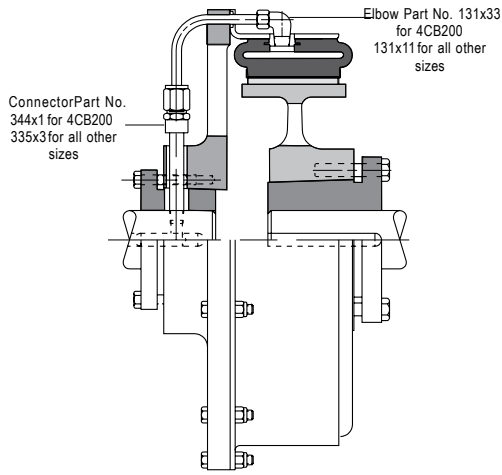

PCB-206 Arrangement

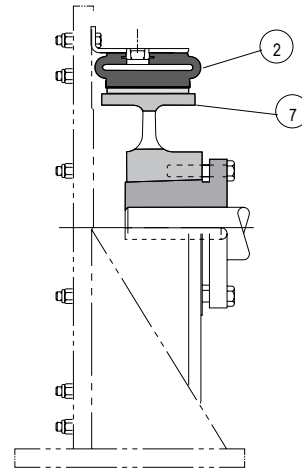

PCB-208 Arrangement

10CB300, 12CB350, 14CB400

Shaft Diameter in	10 Bushing	11 Bushing
1.750	304042-1	304041-11
1.813	304042-2	304041-12
1.875	304042-3	304041-13
1.938	304042-4	304041-14
2.000	304042-5	304041-15
2.063	304042-6	304041-16
2.125	304042-7	304041-17
2.188	304042-8	304041-18
2.250	304042-9	304041-19
2.313	304042-10	304041-20
2.375	304042-11	304041-21
2.438	304042-12	304041-22
2.500	304042-13	304041-23

10CB300, 12CB350, 14CB400

Shaft Diameter in	10 Bushing	11 Bushing
2.563	304044-1	304043-12
2.625	304044-2	304043-13
2.688	304044-3	304043-14
2.750	304044-4	304043-15
2.813	304044-5	304043-16
2.875	304044-6	304043-17
2.938	304044-7	304043-18
3.000	304044-8	304043-19
3.063	304044-9	304043-20
3.125	304044-10	304043-21

Size	1 Element		4 Drum		6 Spider		7 Integral Drum		8 Drum Hub		10 or 11 Bushing	
	Weight lb	Wk ² lb · ft ²	Weight lb	Wk ² lb · ft ²	Weight lb	Wk ² lb · ft ²	Weight lb	Wk ² lb · ft ²	Weight lb	Wk ² lb · ft ²	Weight lb	Wk ² lb · ft ²
4CB200	2.5	0.2	4.2	0.2	3.3	0.1					1.6	.01
6CB200	7	1	5.5	0.3	10	0.9	9	0.3	6	0.2	3.5	0.1
8CB250	9	2	12.5	1.1	16	2	14	1	6	0.2	4.4	0.1
10CB300	19	6	19	2.7	41	5	25	2.6	16	1	16	0.5
12CB350	26	11	30	5.9	44	10	39	5.8	16	1	16	0.5
14CB400	31	17	38	10.5	41	14	48	11.4	23	2	16	0.5

Notes:

- ❶ Dynamic torque shown, static torque approximately 25% greater. Torque in each application is dependent upon air pressure and speed.
- ❷ Tolerance +0.003/-0.000 in.
- ❸ American National Pipe Thread

- ❹ AA2 Rotorseal for 4CB200. B3 Rotorseal for all other sizes. Refer to Section for mounting and dimensional information.
- ❺ For inch series shafting.

Airflex® CB Spider Piping and Configuration

Form CB417 — Shaft to Clutch Element piping

Element Sizes 6 to 14

Section B

Spiders for these sizes have internal air passages in the spider spokes.

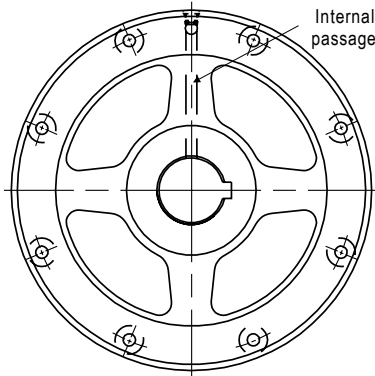

Single Connection

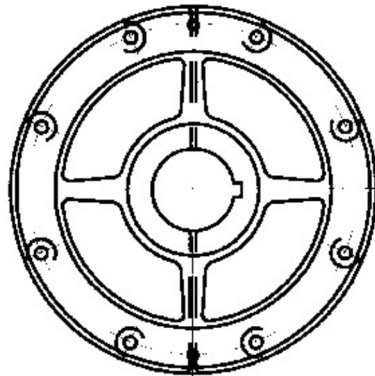

Two Connections

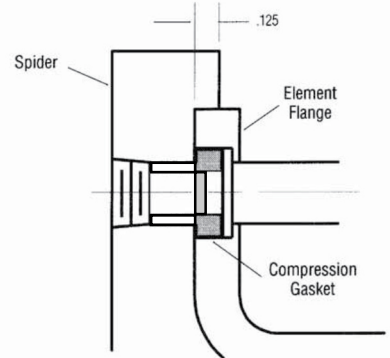

Element Sizes 16 to 45

External piping versus number of connections

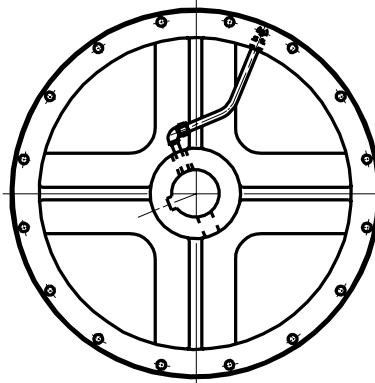

Single Connection

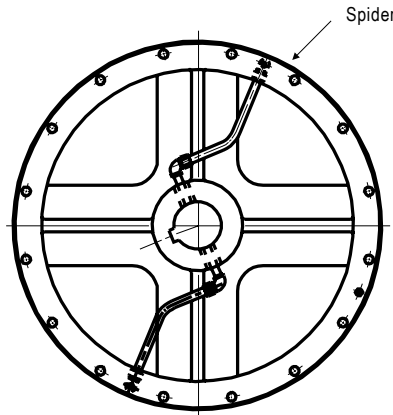

Two Connections

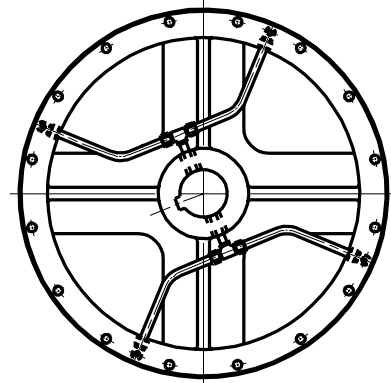

Four Connections

Spider Configuration versus Element size

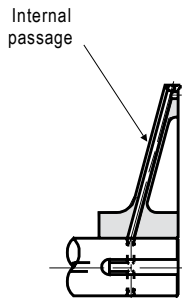

Sizes
6 thru 14

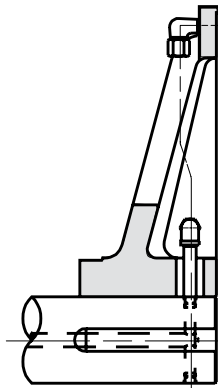

Sizes
16 thru 28

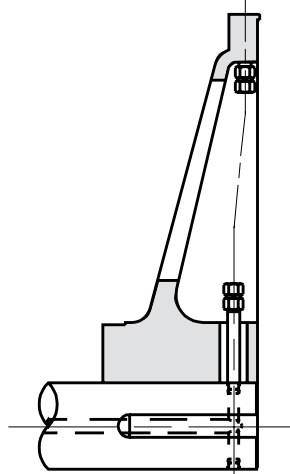

Sizes
30 thru 40

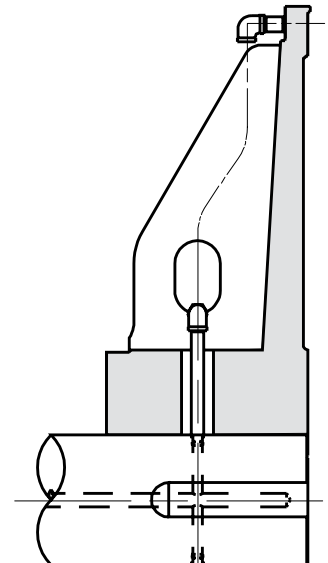

Size
45

Airflex® CB Mounting Components

Form CB415 — Element Spiders —

Dimensional and Technical Data — Single and Dual sizes 6 to 45

Section B

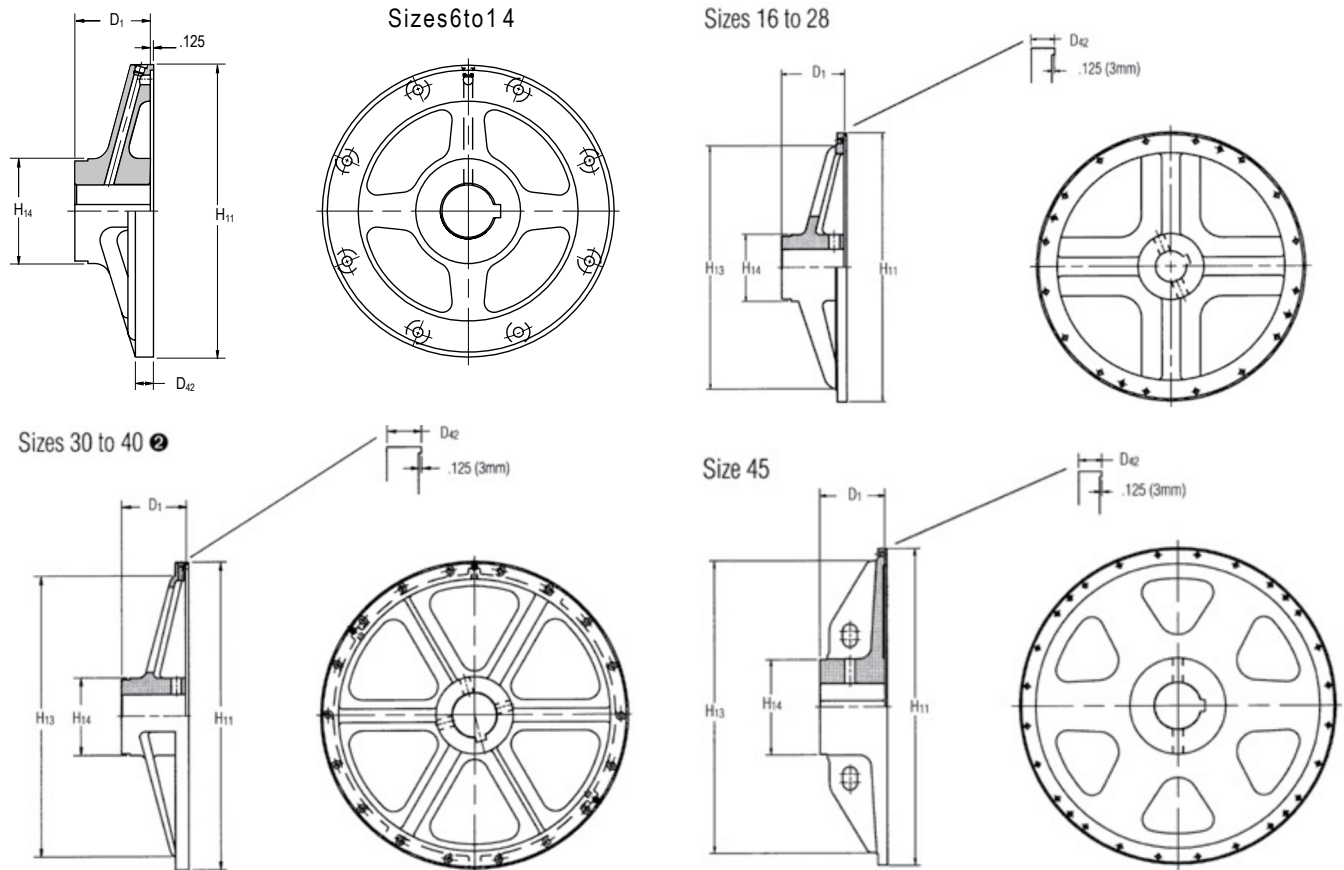

Size	Part No. for:		English Units					SI Units								
	Single Connection	Multi-Connection	Weight lb	Wk ² lb•ft ²	Dimensions in inches					Mass kg	J kg•m ²	Dimensions in millimeters				
					D ₁	D ₄₂	H ₁₁	H ₁₃	H ₁₄			D ₁	D ₄₂	H ₁₁	H ₁₃	H ₁₄
6CB200	408367	408368	15	1.7	2.50	0.56	11.13	N/A	4.00	6,8	0,07	64	14	283	N/A	102
8CB250	408369	408370	19	2.3	2.88	0.56	13.25	N/A	4.00	8,6	0,10	73	14	337	N/A	102
10CB300	408371	408372	40	5.3	3.56	0.62	15.75	N/A	6.00	18	0,22	91	16	400	N/A	152
12CB350	408373	408374	46	8.1	4.00	0.59	18.00	N/A	6.00	21	0,34	102	15	457	N/A	152
14CB400	408375	408376	50	11.2	4.34	0.59	20.00	N/A	6.00	23	0,47	110	15	508	N/A	152
16CB500	N/A	408276	146	53	5.50	1.06	24.00	21.25	7.00	66	2,23	140	27	610	540	178
18CB500	N/A	408277	152	63	5.50	1.06	26.00	23.25	8.00	69	2,65	140	27	660	591	203
20CB500	N/A	408278	183	91	5.50	1.06	28.00	25.25	8.00	83	3,82	140	27	711	641	203
22CB500	N/A	408279	227	123	6.00	1.06	30.00	27.00	8.50	103	5,17	152	27	762	686	216
24CB500	N/A	408280	257	150	6.50	1.06	32.00	29.00	8.50	116	6,30	165	27	813	737	216
26CB525	N/A	408281	298	220	6.50	1.06	34.63	31.00	9.00	135	9,24	165	27	879	787	229
28CB525	N/A	408282	337	270	7.50	1.06	36.63	33.50	9.00	153	11,34	191	27	930	851	229
30CB525	N/A	407096	341	390	7.50	1.69	38.63	35.00	9.50	154	16,38	191	43	981	889	241
32CB525	N/A	407097	392	453	7.50	1.69	40.63	37.00	9.50	178	19,03	191	43	1032	940	241
36CB525	N/A	407098	505	710	8.50	1.69	45.25	41.50	11.38	229	29,82	216	43	1149	1054	289
40CB525	N/A	407099	464	774	8.50	1.69	49.25	46.75	11.00	210	32,51	216	43	1251	1187	279
45CB525	N/A	502369	1294	1887	11.00	1.31	54.25	50.48	16.50	586	79,25	279	33	1378	1282	419

Notes:

- ① Based upon minimum bores.
- ② Air inlet locations vary. Consult factory for exact location.

Airflex® CB Mounting Components

Form CB428 — External Flange Drums —

Dimensional and Technical Data — Single and Dual sizes 6 to 45

Section B

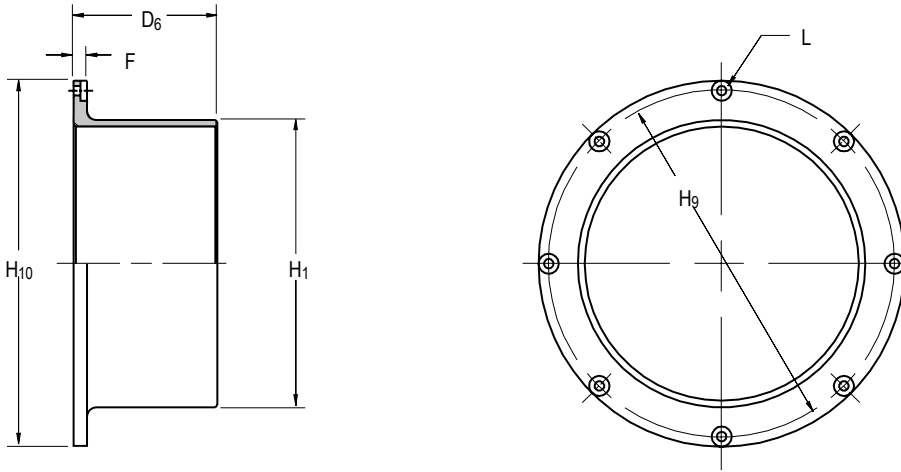

Size	Part Numbers	
	Single Drum	Dual Drum
12CB350	411778	408648
14CB400	411779	411707
16CB500	411780	408682
18CB500	411781	410523
20CB500	411782	404605
22CB500	411783	406030
24CB500	411784	402145
26CB525	411786	411453
28CB525	411785	404942
30CB525	411787	N/A
32CB525	411788	N/A
36CB525	411789	N/A
40CB525	411790	N/A
45CB525	411791	N/A

English Dimensions in inches

English	Single & Dual				Single Drum				Dual Drum									
	F	H ₁₀	D ₆	H ₁	H ₉	H ₁₀ ⊕	L (Bolt)	No.	Dia.	Mass	J	D ₆	H ₉	H ₁₀	L (Bolt)	No.	Dia.	Mass
12CB350	0.75	12	6.00	13.125	13.875	8	0.406	26	6.4	12.06	17.250	18.375	8	0.531	100	28		
14CB400	0.75	14	6.63	17.250	18.375	8	0.531	45	18	13.00	21.375	22.500	6	0.656	103	47		
16CB500	0.75	16	8.00	19.250	20.375	8	0.531	63	31	14.31	25.250	26.500	12	0.656	182	103		
18CB500	0.75	18	8.00	21.375	22.500	6	0.531	72	44	16.00	25.250	26.500	12	0.656	201	126		
20CB500	1.00	20	8.00	25.250	26.500	12	0.656	126	102	16.00	25.250	26.500	12	0.656	191	144		
22CB500	1.00	22	8.00	25.250	26.500	12	0.656	115	103	16.00	25.250	26.500	12	0.656	186	159		
24CB500	1.00	24	8.00	27.250	28.875	12	0.656	130	139	16.00	27.250	28.875	12	0.781	208	212		
26CB525	1.00	26	8.50	29.250	30.750	12	0.781	144	178	17.00	29.250	30.750	12	0.781	234	278		
28CB525	1.00	28	8.50	30.250	31.875	12	0.781	143	200	17.00	30.250	31.875	12	0.781	240	326		
30CB525	1.00	30	8.50	33.000	34.750	12	0.781	166	271									
32CB525	1.00	32	8.50	35.250	36.750	14	0.781	177	327									
36CB525	1.00	36	8.50	39.250	40.750	16	0.781	199	462									
40CB525	1.00	40	8.50	43.250	44.750	16	0.781	220	631									
45CB525	1.00	45	8.50	48.250	49.750	16	0.781	248	893									

Size	F	H ₁₀ ⊕	D ₆	H ₉	H ₁₀ ⊕	L (Bolt)	Weight Wk ²				Weight Wk ²					
							Mass		J		Mass		J			
							lb	kg	lb · ft ²	kg · m ²	lb	kg	lb · ft ²	kg · m ²		
12CB350	19	305	152	333,4	352,4	8	10	2,9	0,27	306	438,2	466,7	8	13	45	1,18
14CB400	19	356	168	438,2	466,7	8	13	8,2	0,76	330	542,9	571,5	6	17	47	1,97
16CB500	19	406	203	489,0	517,5	8	13	14	1,30	363	641,4	673,1	12	17	82	4,33
18CB500	19	457	203	542,9	571,5	6	13	20	1,85	406	641,4	673,1	12	17	91	5,29
20CB500	25	508	203	641,4	673,1	12	17	46	4,28	406	641,4	673,1	12	17	87	6,05
22CB500	25	559	203	641,4	673,1	12	17	47	4,33	406	641,4	673,1	12	17	84	6,68
24CB500	25	610	203	692,2	733,4	12	17	63	5,84	406	692,2	733,4	12	20	94	8,90
26CB525	25	660	216	743,0	781,1	12	20	81	7,48	432	743,0	781,1	12	20	106	11,68
28CB525	25	711	216	768,4	809,6	12	20	91	8,40	432	768,4	809,6	12	20	109	13,69
30CB525	25	762	216	838,2	882,7	12	20	123	11,38							
32CB525	25	813	216	895,4	933,5	14	20	148	13,73							
36CB525	25	914	216	997,0	1035,1	16	20	209	19,40							
40CB525	25	1016	216	1098,6	1136,7	16	20	286	26,50							
45CB525	25	1143	216	1225,6	1263,7	16	20	405	37,51							

SI	Single & Dual	Single Drum	Dual Drum
----	---------------	-------------	-----------

Dimensions in millimeters

Notes:

① Tolerance +0.000/-0.010 in (+0,00/-0,25 mm).

② Tolerance +0.003/-0.000 in (+0,08/-0,00 mm).

Airflex® CB Mounting Components

Form CB420 — Internal Flange Drums —

Dimensional and Technical Data — Single and Dual sizes 6 to 45

Section B

Size	Part Numbers			Size	Part Numbers		
	Single Drum		Dual Drum		Single Drum		Dual Drum
	Thru Holes	Tapped Holes	Thru Holes	Thru Holes	Tapped Holes	Thru Holes	
6CB200	407043	407044	N/A	22CB500	408287	408288	411865
8CB250	407045	407046	N/A	24CB500	407057	407058	411866
10CB300	407047	407048	N/A	26CB525	408289	408342	411867
12CB350	407049	407050	411860	28CB525	407059	407060	411868
14CB400	407051	407052	411861	30CB525	408343	408344	411869
16CB500	407053	407054	411862	32CB525	407061	407062	411870
18CB500	408285	408286	411863	36CB525	407063	407064	411871
20CB500	407055	407056	411864	40CB525	407065	407066	411872

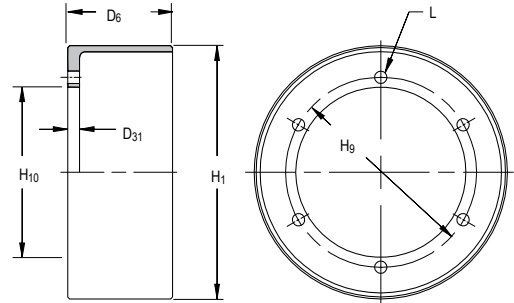

English	Dimensions in inches				Single Drum			Dual Drum					
	D31	H1 Ø	H9	H10 Ø	No. Bolt Holes	Thru	Tapped	D6	Weight Mass	Wk² J	D6	Weight Mass	Wk² J
6CB200	0.50	6	4.250	3.500	6	0.406	3/8-16	3.00	5.5	0.3			
8CB250	0.75	8	5.250	4.250	8	0.406	3/8-16	3.50	12.5	1.1			
10CB300	0.75	10	7.250	6.250	6	0.531	1/2-13	4.06	19	2.7			
12CB350	0.75	12	7.250	6.250	6	0.531	1/2-13	4.68	30	5.9	10.19	61	13
14CB400	0.75	14	9.250	8.250	6	0.531	1/2-13	5.18	38	10.5	11.19	83	24
16CB500	0.75	16	12.000	10.750	6	0.781	3/4-10	6.62	50	19	13.56	109	43
18CB500	1.00	18	13.500	12.125	8	0.781	3/4-10	6.62	67	31	13.56	126	63
20CB500	1.00	20	16.000	14.625	8	0.781	3/4-10	6.62	72	43	13.56	139	87
22CB500	1.00	22	18.500	16.750	10	0.781	3/4-10	6.62	79	58	13.56	152	117
24CB500	1.00	24	19.750	18.000	12	0.781	3/4-10	6.62	93	80	13.56	173	156
26CB525	1.00	26	21.500	19.500	14	0.781	3/4-10	7.06	108	110	14.19	198	211
28CB525	1.00	28	23.500	21.500	16	0.781	3/4-10	7.06	117	140	14.31	216	268
30CB525	1.00	30	25.000	23.000	18	0.781	3/4-10	7.06	140	192	14.31	237	337
32CB525	1.00	32	27.000	25.000	18	0.781	3/4-10	7.06	160	252	14.31	254	413
36CB525	1.00	36	31.000	29.000	20	0.781	3/4-10	7.06	180	319	14.31	287	597
40CB525	1.00	40	34.500	32.500	16	0.781	3/4-10	7.06	209	523	14.31	327	840
45CB525	1.00	45	39.500	37.500	10	1.031	3/4-10	7.06	237	758	14.31	369	1212

Size	D31	H1 Ø	H9	H10 Ø	L (Bolt Holes)	D6	Weight		D6	Weight				
							Mass	Wk² J		Mass	Wk² J			
Single & Dual Drum						No.	Thru	Tapped	mm	kg	kg · m²	mm	kg	kg · m²
6CB200	13	152	108,0	88,9	6	76	2,5	0,01						
8CB250	19	203	133,4	108,0	8	89	5,7	0,05						
10CB300	19	254	184,2	158,8	6	103	8,6	0,11						
12CB350	19	305	184,2	158,8	6	119	14	0,25	259	28	0,55			
14CB400	19	356	235,0	209,6	6	132	17	0,44	284	38	1,01			
16CB500	19	406	304,8	273,1	6	168	23	0,80	344	49	1,81			
18CB500	25	457	342,9	308,0	8	168	30	1,30	344	57	2,65			
20CB500	25	508	406,4	371,5	8	168	33	1,81	344	63	3,65			
22CB500	25	559	469,9	425,5	10	168	36	2,44	344	69	4,91			
24CB500	25	610	501,7	457,2	12	168	42	3,36	344	78	6,55			
26CB525	25	660	546,1	495,3	14	179	49	4,62	360	90	8,86			
28CB525	25	711	596,9	546,1	16	179	53	5,88	363	98	11,26			
30CB525	25	762	635,0	584,2	18	179	63	8,06	363	107	14,15			
32CB525	25	813	685,8	635,0	18	179	72	10,58	363	115	17,35			
36CB525	25	914	787,4	736,6	20	179	81	13,40	363	130	25,07			
40CB525	25	1016	876,3	825,5	16	179	95	21,97	363	148	35,28			
45CB525	25	1143	1003,3	952,5	10	179	107	31,84	363	167	50,90			

Notes:

① Dual drum is only available with tapped holes only.

② Tolerance +0.000/-0.010 in (+0,00/-0,25 mm).

③ Tolerance for sizes:

6 thru 40 +0.003/-0.000 in (+0,08/-0,00 mm)

45 +0.005/-0.000 in (+0,13/-0,00 mm)

④ American National Standard for Unified Screw Threads.

Airflex®CB Mounting Components

Form CB419 — Integral Drum and Hub Dimensional
and Technical Data
Section B

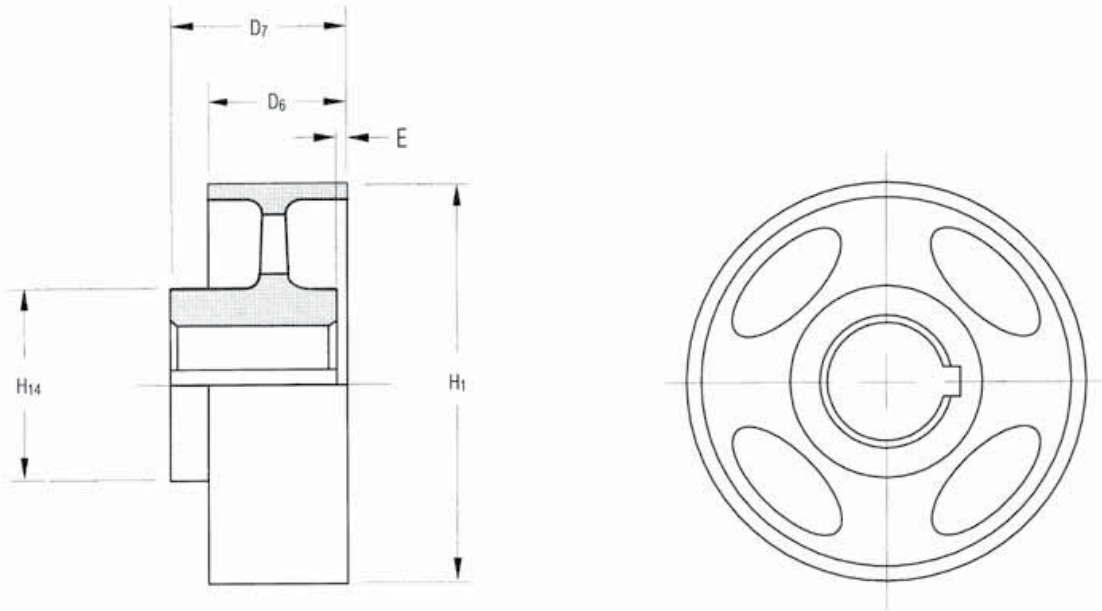

English		Dimensions in inches								
6CB200	10108	10	0.3	0.00	2.00	2.38	2.88	0.94	6	3.25
8CB250	10109	19	0.8	0.00	2.00	2.88	3.50	1.18	8	4.38
10CB300	10110	33	2.5	1.75	3.00	3.50	4.00	1.44	10	4.88
12CB350	10111	53	5.4	1.50	3.31	4.00	4.50	1.69	12	6.13
14CB400	09617	65	8.5	2.00	4.50	4.25	5.00	1.69	14	6.50
18CB500	403257	90	16	2.25	4.50	5.75	6.00	1.50	18	7.00
24CB500	502340	437	129	4.50	6.00	5.75	8.50	-	24	10.50

Size	Part Number	Weight ^⓪		Bore	D ₆	D ₇	E [ⓐ]	H ₁	H ₁₄	
		Mass	J							
		lb	lb · ft ²	Min.	Max.					
		kg	kg · m ²							
6CB200	10108	4,5	0,01	0	51	60	73	23,88	152	83
8CB250	10109	8,6	0,03	0	51	73	89	29,97	203	111
10CB300	10110	15	0,11	44	76	89	102	36,58	254	124
12CB350	10111	24	0,23	38	84	102	114	42,93	305	156
14CB400	09617	29	0,36	51	114	108	127	42,93	356	165
18CB500	402517	41	0,67	57	114	95	152	25,44	457	178
24CB500	502340	198	5,42	114	152	146	216	-	610	267

SI Dimensions in millimeters

Notes:

- ⓪ Based upon minimum bores.
- ⓐ This dimension is maximum and must be specified by customer.

Airflex®CB Mounting Components

Form CB418 — Drum Hub

Dimensional and Technical Data — Single and Dual sizes 6 to 45

Section B

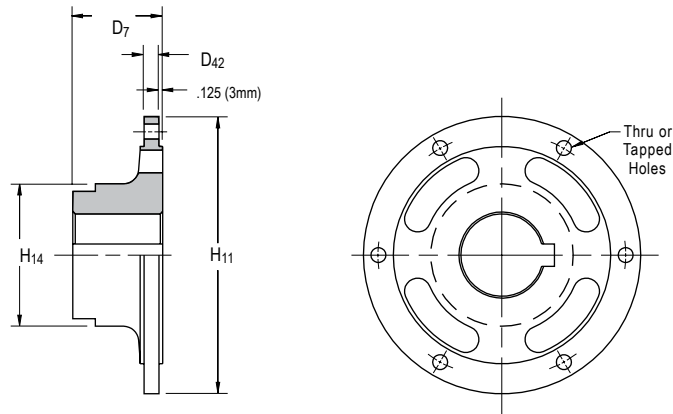

English			Dimensions in inches							
6CB200	408414	408415	9	0.50	1.50	2.50	2.75	0.63	5.00	3.75
8CB250	406900	406901	12	0.50	1.50	2.50	2.75	0.63	6.00	4.00
10CB300	406902	406903	18	0.88	1.50	3.00	3.25	0.63	8.25	5.00
12CB350	406902	406903	18	0.88	1.50	3.00	3.25	0.63	8.25	5.00
14CB400	406904	406905	46	3.50	2.25	4.50	5.00	0.63	10.25	7.00
16CB500	406906	406907	68	6.50	1.75	4.50	5.75	0.75	13.50	7.00
18CB500	406908	406909	74	6.50	2.25	4.75	5.75	0.75	15.00	7.50
20CB500	406910	406911	93	8.50	2.75	4.75	5.75	0.75	17.50	7.50
22CB500	406912	406913	131	29.00	2.75	5.25	6.50	0.75	20.00	8.50
24CB500	406914	406915	132	30.00	2.75	5.25	6.50	0.75	21.50	8.50
26CB525	406916	406917	160	46.00	2.75	5.50	6.50	0.75	23.00	9.00
28CB525	406918	406919	175	61.00	2.75	5.50	6.50	0.75	25.00	9.00
30CB525	406920	406921	214	78.00	3.00	6.00	8.00	0.75	26.50	9.50
32CB525	406922	406923	222	102.00	3.00	6.00	8.00	0.75	28.50	9.50
36CB525	406924	406925	305	159.00	4.00	7.00	9.00	0.75	32.50	11.00
40CB525	406926	406927	358	247.00	4.00	7.00	9.00	0.75	36.00	11.00
45CB525	406928	406929	541	461.00	4.38	8.25	10.00	0.75	41.50	13.50

			Weight	Wk ²						
Size	Part Number		Mass	J	Bore	D ₇	D ₄₂	H ₁₁	H ₁₄	
	Thru Holes	Tapped Holes	lb kg	lb · ft ² kg · m ²	min.	max.				
6CB200	408414	408415	4,1	0,02	38	64	70	16	127	95
8CB250	406900	406901	5,4	0,02	38	64	70	16	152	102
10CB300	406902	406903	8,2	0,04	38	76	83	16	210	127
12CB350	406902	406903	8,2	0,04	38	76	83	16	210	127
14CB400	406904	406905	21	0,15	57	114	127	16	260	178
16CB500	406906	406907	31	0,27	44	114	146	19	343	178
18CB500	406908	406909	34	0,27	57	121	146	19	381	191
20CB500	406910	406911	42	0,36	70	121	146	19	445	191
22CB500	406912	406913	59	1,22	70	133	165	19	508	216
24CB500	406914	406915	60	1,26	70	133	165	19	546	216
26CB525	406916	406917	72	1,93	70	140	165	19	584	229
28CB525	406918	406919	79	2,56	70	140	165	19	635	229
30CB525	406920	406921	97	3,28	76	152	203	19	673	241
32CB525	406922	406923	101	4,28	76	152	203	19	724	241
36CB525	406924	406925	138	6,68	102	178	229	19	826	279
40CB525	406926	406927	162	10,37	102	178	229	19	914	279
45CB525	406928	406929	245	19,36	111	210	254	19	1054	343

Notes:

- ① Based upon minimum bores.

Airflex®VC Construction

Section B



The type VC element assembly is specifically designed and built for severe clutch or brake applications in which large inertia loads and sustained slippage would normally result in loss of torque and reduced operating life.

VC design and construction is different from the CB and CM elements in that the torque is transmitted by torque bars rather than the sidewalls of the actuating tube. The loose actuating tube is contained within a housing formed by a rim and two side plates, and is replaceable. The torque bars, which are held in position by the side plates, pass through cavities in the backing plates of the friction shoes. Pressurizing the actuating tube forces the friction shoes to engage around a cylindrical drum. Leaf springs in the torque bar cavities of the backing plates retract the friction shoes when the actuating tube pressure is released. Element torque capacity is dependent upon the applied pressure and rotating speed. Catalog ratings are given at 75 psi (5,2 bar) and zero rpm. Maximum recommended pressure is 125 psi (8,6 bar). Adjustment for pressure and speed is explained under Selection Procedure. VC elements are available in 24 sizes which are identified by

the drum diameter in inches on which they constrict and the width in inches of its friction lining. For a given drum diameter it is possible to have two different lining widths. For this reason, the elements are grouped by lining width into a narrow series and a wide series. As an example, the narrow series 20VC600 and the wide series 20VC1000 both constrict on a 20 inch diameter drum. But, the narrow unit has a lining width of 6 inches, and the wide unit has a lining width of 10 inches. The smallest VC element will constrict on a 11.5 inch (292 mm) diameter drum and the largest on a 76 inch (1930 mm) diameter drum.

Two elements of a narrow series can be bolted together to form a dual element having twice the torque capacity of a single element. With the exception of the 14VC1000 element, the wide series elements can also be dualled. The large drum hub diameter and small drum diameter restricts the radial space available for mechanically connecting the drums to the hub and makes dualing the 14VC1000 elements impractical.

The VC design offers the following features in addition to the constricting features described earlier in this section.

Airflex®VC Features

Section B

Ventilated Construction

Friction shoe backing plates have large air passages through their entire length. This construction coupled with scalloped side plates allows cooling air to flow through the element. In addition, the large exposed inside diameter assures the coolest possible operation. None of the heat is generated deep in the element's internal parts where it can be trapped. The open construction assures rapid heat dissipation.

Serviceability

The VC clutch can be dismantled on the shaft to gain access to its component parts. All parts are available as replacement parts.

A limited number of element sizes are available in a split configuration. They are used in applications having limited axial access for element maintenance. The following pages give additional descriptive information, selection procedures and common clutch and brake arrangements for the complete VC product line.

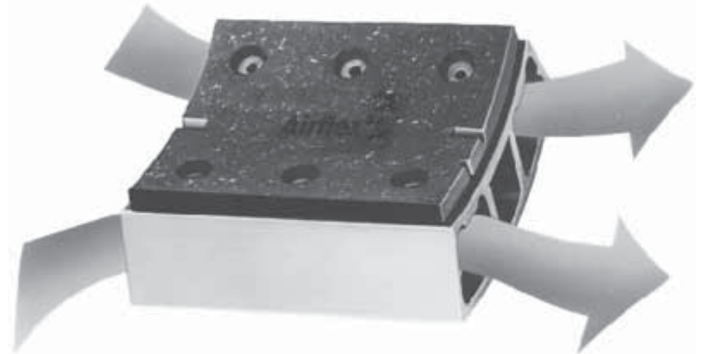

Where Used:

- Grinding Mills
- Marine Propulsion
- Metal Forming Machinery
- Oil Field Machinery

Narrow Sizes	Torque Rating	
	lb · in @ 75 psi	N · m @5, 2 bar
11.5VC500	27000	3050
14VC500	39200	4430
16VC600	65000	7350
20VC600	93000	10500
24VC650	135000	15300
28VC650	182000	20600
33VC650	255000	28800
37VC650	320000	36200
42VC650	380000	42900

Wide Sizes	Torque Rating	
	lb · in @ 75 psi	N · m @5, 2 bar
14VC1000	85000	9610
16VC1000	114000	12900
20VC1000	161000	18200
24VC1000	219000	24700
28VC1000	296000	33400
32VC1000	415000	46900
38VC1200	680000	76800
42VC1200	819000	92500
46VC1200	950000	107000
52VC1200	1215000	137000
51VC1600	1610000	182000
60VC1600	2183000	247000
66VC1600	2800000	316000
76VC1600	3660000	413057
76VC2000	Consult Factory	

Airflex®VC Component Descriptions

Section B

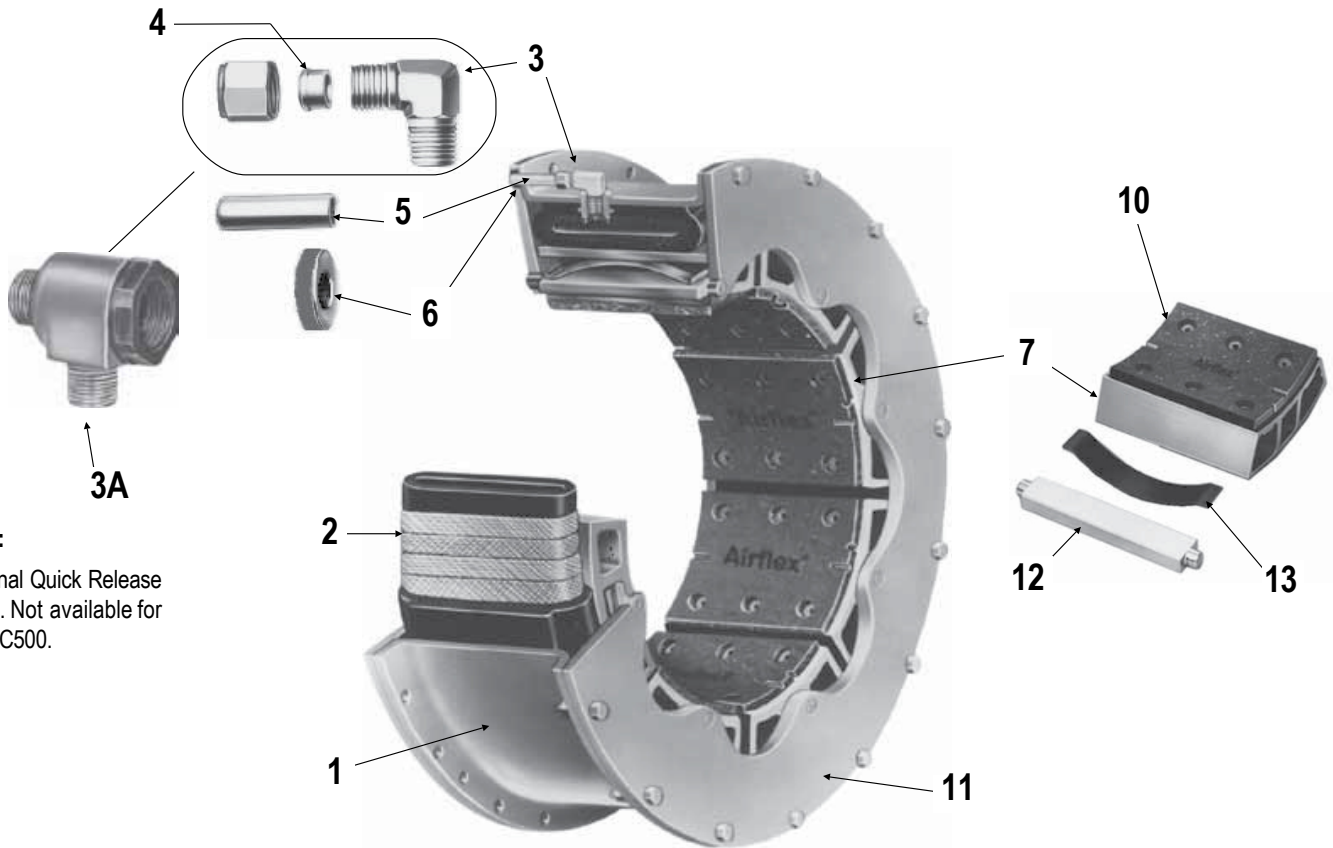

Note:

Optional Quick Release Valve. Not available for 11.5VC500.

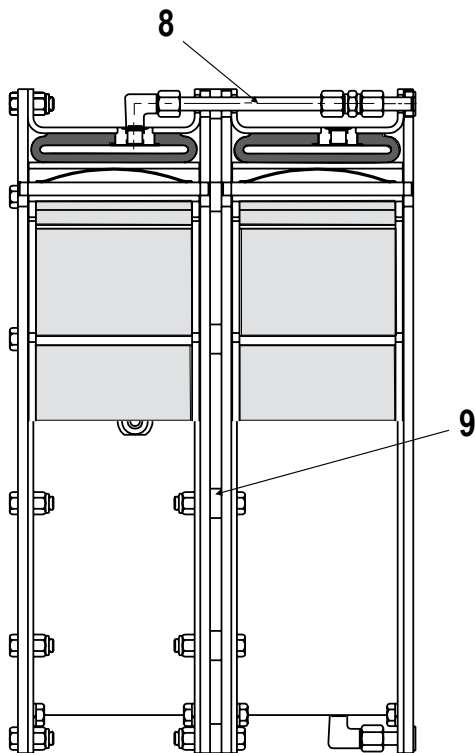

Item	Component Description
1	Rim
2	Tube (with valve stem snap rings where required)
3	Elbow Assembly
3A	Optional -Quick Release Valve Assembly
4	Compression Ring (included with items 3&3A)
5	Air Connection Tube
6	Air Connection Gasket
7	Friction Shoe Assembly
8	Air Tube Group (Dual Mounted)
9	Spacer Group (Dual Mounted)
10	Replacement Friction Lining & Fastener Kit
11	Side Plate (2 required)
12	Torque Bar
13	Release Spring
7, 12, & 13	Friction Shoe, Torque Bar & Spring Kit

Airflex®VC Element Part Numbers

Section B

An alpha suffix is added to the basic element part number to completely describe the element configuration.

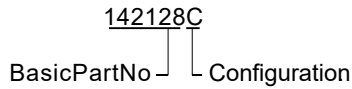

The basic element part number is shown on the element catalog pages. Alphas for the more common element configurations are shown on this page. The element part number used in the above example identifies a dual 42VC1200 element equipped with standard friction linings and four side connections.

Alpha Suffixes for Single VC Elements

Number of Valves, Side Connections or QRV's	Type of Lining	Alpha Suffixes		
		Valves Only	With Side Connections	With QRV's
1	Standard	-	HJ	HM
1	Cork	-	LR	MR
2	Standard	HA	HP	HN
2	Cork	HB	HS	HK
4	Standard	HA	HC	HE
4	Cork	HB	HD	HF

Alpha Suffixes for Dual VC Elements

Number of Valves, Side Connections or QRV's	Type of Lining	Alpha Suffixes		
		Valves Only	With Side Connections	With QRV's
2	Standard	-	none	E
2	Cork	AA	A	AK
4	Standard	F	C	D
4	Cork	AA	X	J

Airflex® Single Narrow VCElements

Form VC-501 Sizes 11.5 to 42

Section B

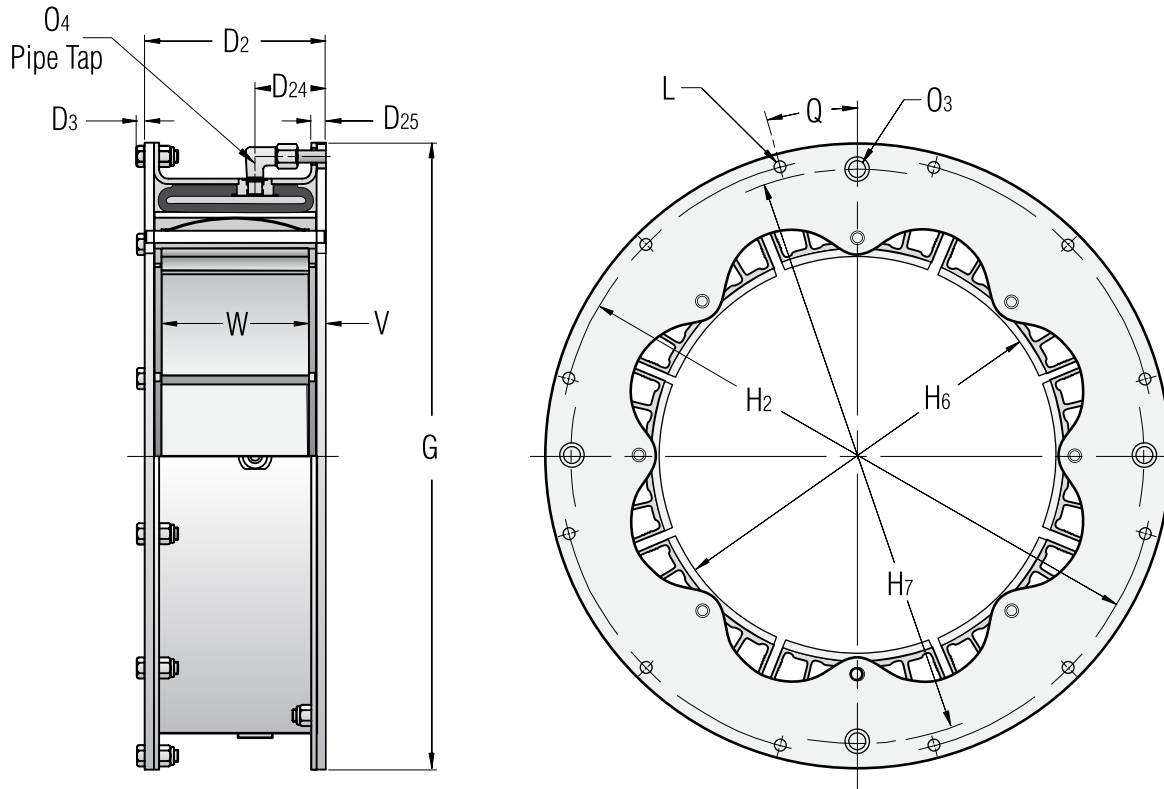

ENGLISH

Size	MrTorque Part Number	Rating (lb-in @ 75 psi)	Maximum Speed (rpm)	C _s Centrifugal loss (psi/rpm ²)	Wk ² (lb-ft ²)	Weight (lb)	Friction Area (in ²)	Friction Lining Thickness (inches)	Worn	AirTube Cavity (in ³)	Minimum Drum Diameter (inches)
11.5VC500	142639	27,000	1800	23 E-06	43	96	166	0.32	0.16	70	11.41
14VC500	143829	39,200	1500	28 E-06	78	128	205	0.32	0.16	95	13.91
16VC600	142640	65,000	1400	29 E-06	115	151	283	0.32	0.16	120	15.91
20VC600	142641	93,000	1200	40 E-06	193	179	380	0.32	0.16	140	19.88
24VC650	142642	135,000	1050	49 E-06	369	246	466	0.44	0.16	200	23.88
28VC650	142643	182,000	1000	58 E-06	537	280	548	0.44	0.16	270	27.81
33VC650	142644	255,000	900	74 E-06	1083	392	643	0.57	0.28	360	32.81
37VC650	142645	320,000	800	90 E-06	1400	433	720	0.57	0.28	400	36.81
42VC650	142647	380,000	800	95 E-06	1990	485	822	0.57	0.28	440	41.81

SI

Size	Part Number	MrTorque Rating (N·m @ 5,2 bar)	Maximum Speed (rpm)	C _s Centrifugal loss (bar/rpm ²)	J (kg·m ²)	Mass (kg)	Friction Area (cm ²)	Friction Lining Thickness (mm)	Worn	AirTube Cavity (dm ³)	Minimum Drum Diameter (mm)
11.5VC500	142639	3,050	1800	1,59 E-06	1,81	43	1071	8	4	1,15	290
14VC500	143829	4,430	1500	1,93 E-06	3,28	58	1322	8	4	1,56	353
16VC600	142640	7,340	1400	2,00 E-06	4,83	68	1825	8	4	1,97	404
20VC600	142641	10,505	1200	2,76 E-06	8,11	81	2451	8	4	2,30	505
24VC650	142642	15,250	1050	3,38 E-06	15,50	111	3006	11	4	3,28	607
28VC650	142643	20,560	1000	4,00 E-06	22,55	127	3535	11	4	4,43	706
33VC650	142644	28,810	900	5,11 E-06	45,49	178	4147	14	7	5,90	833
37VC650	142645	36,155	800	6,21 E-06	58,80	196	4644	14	7	6,56	935
42VC650	142647	42,930	800	6,56 E-06	83,58	220	5302	14	7	7,22	1062

Airflex® Single Narrow VCElements

Form VC-501 Sizes 11.5 to 42

Section B

ENGLISH

Size	(Dimensions in inches)				G	H ₂	H ₆	H ₇	L No.	L Dia.	O ₃	O ₄ No.	O ₄ Size	Q (Deg)	V	W No.	W Width
	D ₂	D ₃	D ₂₄	D ₂₅													
11.5VC500	6.13	0.23	2.38	0.38	19.625	18.875	11.63	18.88	16	0.375	0.31	2	⅝-18 NPT	11.25	0.56	8	5.00
14VC500	6.13	0.31	2.88	0.58	23.500	22.500	14.22	22.25	8	0.500	0.38	4	⅝-18 NPT	22.50	0.56	8	5.00
16VC600	7.38	0.31	2.88	0.59	25.500	24.375	16.22	24.38	12	0.500	0.38	4	⅝-18 NPT	15.00	0.69	8	6.00
20VC600	7.38	0.31	2.88	0.59	29.500	28.375	20.22	28.38	12	0.500	0.38	4	⅝-18 NPT	15.00	0.69	10	6.00
24VC650	7.69	0.39	2.88	0.63	34.000	32.750	24.22	32.50	16	0.625	0.50	4	½-14 NPT	11.25	0.59	12	6.50
28VC650	7.69	0.39	2.88	0.63	38.000	36.750	28.22	36.50	16	0.625	0.50	4	½-14 NPT	11.25	0.59	14	6.50
33VC650	7.69	0.47	3.13	0.63	44.625	43.125	33.22	43.25	18	0.750	0.63	4	¾-14 NPT	15.00	0.59	16	6.50
37VC650	7.69	0.47	3.13	0.69	48.625	47.125	37.22	47.25	20	0.750	0.63	4	¾-14 NPT	9.00	0.59	18	6.50
42VC650	7.69	0.47	3.13	0.66	53.625	52.125	42.22	52.25	24	0.750	0.63	4	¾-14 NPT	7.50	0.59	20	6.50

SI

Size	(Dimensions in millimeters)				G	H ₂	H ₆	H ₇	L No.	L Dia.	O ₃	O ₄ No.	O ₄ Size	Q (Deg)	V	W No.	W Width
	D ₂	D ₃	D ₂₄	D ₂₅													
11.5VC500	156	6	60	10	498,5	479,4	295	479	16	9,5	8	2	⅝-18 NPT	11,25	14	8	127
15VC500	156	8	73	15	596,9	571,5	361	565	8	12,7	10	4	⅝-18 NPT	22,50	14	8	127
16VC600	187	8	73	15	647,7	619,1	412	619	12	12,7	10	4	⅝-18 NPT	15,00	17	8	152
20VC600	187	8	73	15	749,3	720,7	514	721	12	12,7	10	4	⅝-18 NPT	15,00	17	10	152
24VC650	195	10	73	16	863,6	831,9	615	826	16	15,9	13	4	½-14 NPT	11,25	15	12	165
28VC650	195	10	73	16	965,2	933,5	717	927	16	15,9	13	4	½-14 NPT	11,25	15	14	165
33VC650	195	12	79	16	1133,5	1095,4	844	1099	18	19,1	16	4	¾-14 NPT	15,00	15	16	165
37VC650	195	12	79	17	1235,1	1197,0	945	1200	20	19,1	16	4	¾-14 NPT	9,00	15	18	165
42VC650	195	12	79	17	1362,1	1324,0	1072	1327	24	19,1	16	4	¾-14 NPT	7,50	15	20	165

Notes

Part Number refers to basic part number only. When ordering, the number of air inlets and type of connection must be specified.

M_r — Dynamic torque shown, static torque approximately 25% greater. Torque in each application is dependent upon air pressure and speed.

Tolerance for sizes (G):

11.5 thru 20
+0.000/-0.005 in
(+0,00/-0,13 mm)

24 thru 28
+0.000/-0.008 in
(+0,00/-0,20 mm)

33 thru 42
+0.000/-0.010 in

(+0,00/-0,25 mm)

(L) Tolerance:

+0.005/-0.000 in
(+0,13/-0,00 mm)

(O₄) — Sizes 11.5 available with one or two inlets. All other sizes have four inlets.

(Maximum Speed)—
Maximum rpm is dependent upon operating conditions and varies for each application. Consult factory for applications exceeding these speeds.

(Air Tube Cavity) — Drum contact with worn shoes.

Airflex® Dual Narrow VCElements

Form VC-502 Sizes 11.5 to 42

Section B

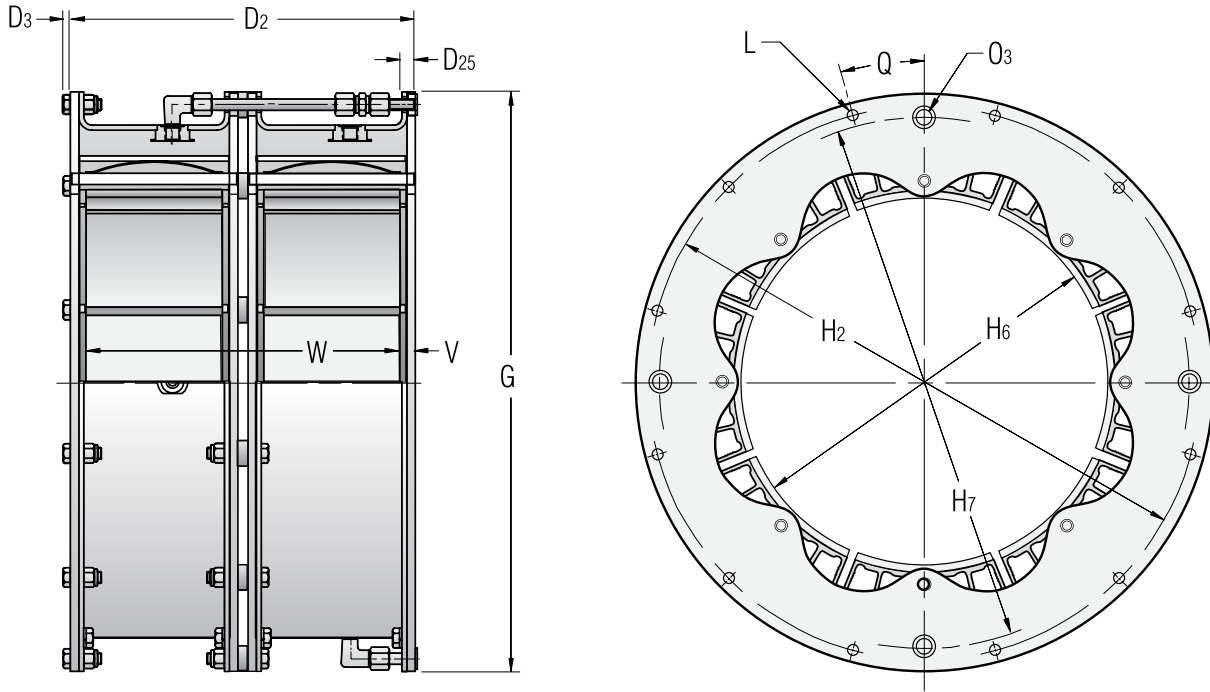

ENGLISH

Size	Part Number	M _t Torque Rating lb·in@ 75 psi	Max. Speed (rpm)	C _s Centrifugal Loss (psi/rpm ²)	Wk ² (lb·ft ²)	Weight (lb)	Friction Area (in ²)	Friction New	Lining Thickness (ins) Worn	AirTube Cavity (in ³)	Minimum Drum Diameter (ins)
11.5VC500	142112	5,4000	1800	23 E-06	86	197	332	0.32	0.16	140	11.41
14VC500	142114	78,400	1500	28 E-06	156	258	410	0.32	0.16	190	13.91
16VC600	142115	130,000	1400	29 E-06	230	307	566	0.32	0.16	240	15.91
20VC600	142116	186,000	1200	40 E-06	386	363	760	0.32	0.16	280	19.88
24VC650	142117	270,000	1050	49 E-06	738	497	932	0.44	0.16	400	23.88
28VC650	142118	364,000	1000	58 E-06	1074	565	1096	0.44	0.16	540	27.81
33VC650	142119	510,000	900	74 E-06	2166	784	1286	0.57	0.28	720	32.81
37VC650	142120	640,000	800	90 E-06	2800	871	1440	0.57	0.28	800	36.81
42VC650	142121	760,000	800	95 E-06	3980	980	1644	0.57	0.28	880	41.81

Size	Part Number	M _t Torque Rating N·m@ 5,2 bar	Max. Speed (rpm)	C _s Centrifugal Loss (bar/rpm ²)	J (kg·m ²)	Mass (kg)	Friction Area (cm ²)	Friction New	Lining Thickness (mm) Worn	AirTube Cavity (dm ³)	Minimum Drum Diameter (mm)
11.5VC500	142112	6,100	1800	1,59 E-06	3,61	89	2141	8	4	2,30	290
14VC500	142114	8,860	1500	1,93 E-06	6,55	117	2645	8	4	3,12	353
16VC600	142115	14,690	1400	2,00 E-06	9,66	139	3651	8	4	3,94	404
20VC600	142116	21,010	1200	2,76 E-06	16,21	164	4902	8	4	4,59	505
24VC650	142117	30,500	1050	3,38 E-06	31,00	225	6011	11	4	6,56	607
28VC650	142118	41,125	1000	4,00 E-06	45,11	256	7069	11	4	8,86	706
33VC650	142119	57,620	900	5,11 E-06	90,97	355	8295	14	7	11,8	833
37VC650	142120	72,310	800	6,21 E-06	117,6	395	9288	14	7	13,1	935
42VC650	142121	85,870	800	6,56 E-06	167,2	444	10604	14	7	14,4	1062

Airflex® Dual Narrow VCElements

Form VC-502 Sizes 11.5 to 42

Section B

ENGLISH

Size	(Dimensions in inches)							L No.	L Dia	O ₃ No.	O ₃ Size	Q (Deg)	V	W No.	W Width
	D ₂	D ₃	D ₂₅	G	H ₂	H ₆	H ₇								
11.5VC500	12.75	0.23	0.56	19.625	18.875	11.63	18.88	16	0.375	2	0.31	11.25	0.56	16	11.63
14VC500	12.69	0.31	0.56	23.500	22.500	14.22	22.25	8	0.500	4	0.38	22.50	0.56	16	11.57
16VC600	15.19	0.31	0.56	25.500	24.375	16.22	24.38	12	0.500	4	0.38	15.00	0.69	16	13.81
20VC600	15.19	0.31	0.56	29.500	28.375	20.22	28.38	12	0.500	4	0.38	15.00	0.69	20	13.81
24VC650	15.94	0.39	0.63	34.000	32.750	24.22	32.50	16	0.625	4	0.50	11.25	0.59	24	14.75
28VC650	15.94	0.39	0.63	38.000	36.750	28.22	36.50	16	0.625	4	0.50	11.25	0.59	28	14.75
33VC650	15.94	0.47	0.69	44.625	43.125	33.22	43.25	18	0.750	4	0.63	15.00	0.59	32	14.75
37VC650	15.94	0.47	0.69	48.625	47.125	37.22	47.25	20	0.750	4	0.63	9.00	0.59	36	14.75
42VC650	15.94	0.47	0.69	53.625	52.125	42.22	52.25	24	0.750	4	0.63	7.50	0.59	40	14.75

SI

Size	(Dimensions in millimeters)							L No.	L Dia	O ₃ No.	O ₃ Size	Q (Deg)	V	W No.	W Width
	D ₂	D ₃	D ₂₅	G	H ₂	H ₆	H ₇								
11.5VC500	324	6	14	498,5	479,4	295	479	16	9,5	2	8	11,25	14	16	295
14VC500	322	8	14	596,9	571,5	361	565	8	12,7	4	10	22,50	14	16	294
16VC600	386	8	14	647,7	619,1	412	619	12	12,7	4	10	15,00	17	16	351
20VC600	386	8	14	749,3	720,7	514	721	12	12,7	4	10	15,00	17	20	351
24VC650	405	10	16	863,6	831,9	615	826	16	15,9	4	13	11,25	15	24	375
28VC650	405	10	16	965,2	933,5	717	927	16	15,9	4	13	11,25	15	28	375
33VC650	405	12	18	1133,5	1095,4	844	1099	18	19,1	4	16	15,00	15	32	375
37VC650	405	12	18	1235,1	1197,0	945	1200	20	19,1	4	16	9,00	15	36	375
42VC650	405	12	18	1362,1	1324,0	1072	1327	24	19,1	4	16	7,50	15	40	375

Notes:

Part Number refers to basic part number only. When ordering, the number of air inlets and type of connection must be specified.

M_r — Dynamic torque shown, static torque approximately 25% greater. Torque in each application is dependent upon air pressure and speed.

Tolerance for sizes (G):

11.5 thru 20
+0.000/-0.005 in
(+0,00/-0,13 mm)

24 thru 28
+0.000/-0.008 in
(+0,00/-0,20 mm)

33 thru 42
+0.000/-0.010 in
(+0,00/-0,25 mm)

(L) Tolerance:
+0.005/-0.000 in
(+0,13/-0,00 mm)

(O₄) — Sizes 11.5 available with one or two inlets. All other sizes have four inlets.

(Maximum Speed) — Maximum rpm is dependent upon operating conditions and varies for each application. Consult factory for applications exceeding these speeds.

(Air Tube Cavity) — Drum contact with worn shoes.

Airflex® Single Wide VCElements

Form VC-503 Sizes 14 to 76

Section B

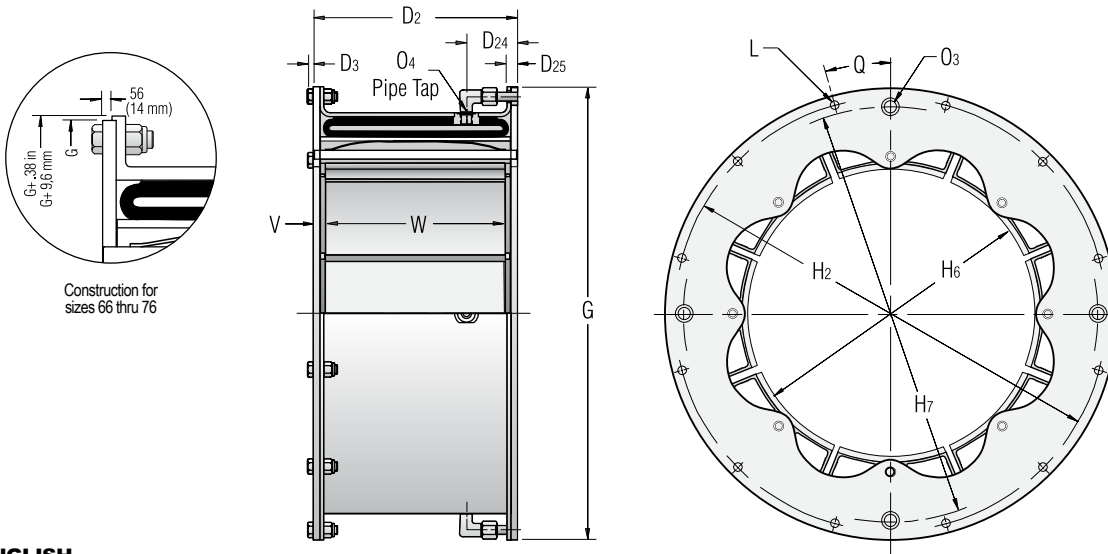

ENGLISH

Size	Part Number	M _r Torque Rating lb·in@ 75 psi	Max. Speed (rpm)	C _s Centrifugal Loss (psi/rpm ²)	Wk ² (lb·ft ²)	Weight (lb)	Friction Area (in ²)	Friction New	Lining Thickness (ins) Worn	AirTube Cavity (in ³)	Minimum Drum Diameter (ins)
14VC1000	142838	85,000	1800	22 E-06	127	213	350	0.32	0.16	185	13.91
16VC1000	142821	114,000	1400	27 E-06	212	240	470	0.32	0.16	255	15.91
20VC1000	142832	161,000	1300	37 E-06	309	282	635	0.32	0.16	310	19.87
24VC1000	142675	219,000	1250	46 E-06	552	378	720	0.44	0.16	465	23.87
28VC1000	142674	296,000	1100	55 E-06	826	431	840	0.44	0.16	530	27.81
32VC1000	142673	415,000	1050	63 E-06	1570	624	960	0.57	0.38	600	31.81
38VC1200	142739	680,000	740	82 E-06	2330	684	1360	0.57	0.38	755	37.81
42VC1200	142677	819,000	670	86 E-06	3670	895	1500	0.57	0.38	850	41.75
46VC1200	142671	950,000	600	108 E-06	4830	980	1410	0.68	0.38	1205	45.75
52VC1200	142841	1,215,000	550	127 E-06	7285	1310	1590	0.68	0.38	1510	51.75
51VC1600	142835	1,610,000	550	125 E-06	10580	1830	2380	0.66	0.30	2000	50.75
60VC1600	142915	2,183,000	520	145 E-06	20532	2374	2800	0.66	0.30	2350	59.75
66VC1600	142097	2,800,000	480	185 E-06	24850	2630	3080	0.66	0.30	1950	65.75
76VC1600	—	—	—	Consult Factory	—	—	—	—	—	—	—

Size	Part Number	M _r Torque Rating N·m@ 5,2 bar	Max. Speed (rpm)	C _s Centrifugal Loss (bar/rpm ²)	J (kg·m ²)	Mass (kg)	Friction Area (cm ²)	Friction New	Lining Thickness (mm) Worn	AirTube Cavity (dim ³)	Minimum Drum Diameter (mm)
14VC1000	142838	9,605	1800	1,52 E-06	5,33	96	2258	8	4	3,03	353
16VC1000	142821	12,880	1400	1,86 E-06	8,90	109	3032	8	4	4,18	404
20VC1000	142832	18,190	1300	2,55 E-06	12,98	128	4096	8	4	5,08	505
24VC1000	142675	24,745	1250	3,17 E-06	23,18	171	4644	11	4	7,63	606
28VC1000	142674	33,445	1100	3,80 E-06	34,69	195	5418	11	4	8,69	706
32VC1000	142673	46,890	1050	4,35 E-06	65,94	283	6192	14	10	9,84	808
38VC1200	142739	76,830	740	5,66 E-06	97,86	310	8772	14	10	12,4	960
42VC1200	142677	92,535	670	5,93 E-06	154,1	405	9675	14	10	13,9	1060
46VC1200	142671	107,335	600	7,45 E-06	202,9	444	9097	17	10	19,8	1162
52VC1200	142841	137,275	550	8,76 E-06	306,0	594	10256	17	10	24,8	1314
51VC1600	142835	181,905	550	8,63 E-06	444,4	830	15351	17	8	32,8	1289
60VC1600	142915	246,645	520	10,01 E-06	852,3	1077	18060	17	8	38,5	1518
66VC1600	142097	316,355	480	12,83 E-06	1044	1191	19866	17	8	32,1	1670
76VC1600	—	—	—	Consult Factory	—	—	—	—	—	—	—

Airflex® Single Wide VCElements

Form VC-503 Sizes 14 to 76

Section B

ENGLISH

Size	(Dimensions in inches)				G	H ₂	H ₆	H ₇	L No.	L Dia.	O ₃	O ₄ No.	O ₄ Size	Q (Deg)	V	W No.	W Width
	D ₂	D ₃	D ₂₄	D ₂₅													
14VC1000	11.56	0.31	2.88	0.63	23.500	22.500	14.22	22.25	8	0.500	0.38	4	38-18 NPT	22.50	0.78	8	10
16VC1000	11.56	0.31	2.88	0.63	25.500	24.375	16.22	24.38	12	0.500	0.38		38-18 NPT	15.00	0.78	8	10
20VC1000	11.56	0.31	2.88	0.63	29.500	28.375	20.22	28.38	12	0.500	0.38		38-18 NPT	15.00	0.78	8	10
24VC1000	11.56	0.39	2.88	0.63	34.000	32.750	24.22	32.50	16	0.625	0.50		½-14 NPT	11.25	0.78	10	10
28VC1000	11.56	0.39	2.88	0.63	38.000	36.750	28.22	36.50	16	0.625	0.50		½-14 NPT	11.25	0.78	10	10
32VC1000	11.63	0.39	2.88	0.63	43.875	42.625	32.22	42.13	24	0.625	0.50		½-14 NPT	7.50	0.81	12	10
38VC1200	13.75	0.47	3.13	0.69	49.375	47.875	38.22	48.00	20	0.750	0.63		¾-14 NPT	9.00	0.88	12	12
42VC1200	13.75	0.47	3.13	0.66	53.625	52.125	42.22	52.25	24	0.750	0.63		¾-14 NPT	7.50	0.88	14	12
46VC1200	13.75	0.55	4.88	0.78	60.250	58.500	46.25	57.50	24	0.875	0.63		¾-14 NPT	7.50	0.88	16	12
52VC1200	14.25	0.55	7.13	1.13	67.000	65.500	52.25	65.00	32	0.875	0.88		1-11 ½ NPT	5.63	1.13	18	12
51VC1600	18.25	0.55	9.13	1.13	67.000	65.500	51.25	65.00	32	0.875	0.88		1-11 ½ NPT	5.63	1.13	18	16
60VC1600	18.50	0.61	9.25	1.38	77.000	75.000	60.43	74.25	36	1.000	0.88		1-11 ½ NPT	5.00	1.25	20	16
66VC1600	18.50	0.78	9.25	1.38	82.123	79.625	66.22	78.38	40	1.312	0.88		1-11 ½ NPT	5.00	1.25	22	16

SI

Size	(Dimensions in millimeters)				G	H ₂	H ₆	H ₇	L No.	L Dia.	O ₃	O ₄ No.	O ₄ Size	Q (Deg)	V	W No.	W Width
	D ₂	D ₃	D ₂₄	D ₂₅													
14VC1000	294	8	73	16	596,9	571,5	361	565	8	12,7	10	4	38-18 NPT	22,50	20	8	254
16VC1000	294	8	73	16	647,7	619,1	412	619	12	12,7	10	4	38-18 NPT	15,00	20	8	254
20VC1000	294	8	73	16	749,3	720,7	514	721	12	12,7	10	4	38-18 NPT	15,00	20	8	254
24VC1000	294	10	73	16	863,6	831,9	615	826	16	15,9	13	4	½-14 NPT	11,25	20	10	254
28VC1000	294	10	73	16	965,2	933,5	717	927	16	15,9	13	4	½-14 NPT	11,25	20	10	254
32VC1000	295	10	73	16	1114,4	1082,7	818	1070	24	15,9	13	4	½-14 NPT	7,50	21	12	254
38VC1200	349	12	79	18	1254,1	1216,0	971	1219	20	19,1	16	4	¾-14 NPT	9,00	22	12	305
42VC1200	349	12	79	17	1362,1	1324,0	1072	1327	24	19,1	16	4	¾-14 NPT	7,50	22	14	305
46VC1200	349	14	124	20	1530,4	1485,9	1175	1461	24	22,2	16	4	¾-14 NPT	7,50	22	16	305
52VC1200	362	14	181	29	1701,8	1663,7	1327	1651	32	22,2	22	4	1-11 ½ NPT	5,63	29	18	305
51VC1600	464	14	232	29	1701,8	1663,7	1302	1651	32	22,2	22	4	1-11 ½ NPT	5,63	29	18	406
60VC1600	470	15	235	35	1955,8	1905,0	1535	1886	36	25,4	22	4	1-11 ½ NPT	5,00	32	20	406
66VC1600	470	20	235	35	2085,9	2022,5	1682	1991	40	33,3	22	4	1-11 ½ NPT	5,00	32	22	406

Notes:

Part Number refers to basic part number only. When ordering, the number of air inlets and type of connection must be specified.

M_r — Dynamic torque shown, static torque approximately 25% greater. Torque in each application is dependent upon air pressure and speed.

Tolerance for sizes (G):

14 thru 20
+0.000/-0.005 in

(+0,00/-0,13 mm)
24 thru 28
+0.000/-0.008 in
(+0,00/-0,20 mm)
32 thru 60
+0.000/-0.010 in
(+0,00/-0,25 mm)
66 thru 76
+0.000/-0.005 in
(+0,00/-0,13 mm)
(L) Tolerance:

+0.005/-0.000 in
(+0,13/-0,00 mm)
(Maximum Speed)—
Maximum rpm is dependent upon operating conditions and varies for each application. Consult factory for applications exceeding these speeds.
(Air Tube Cavity) — Drum contact with worn shoes.

Airflex® Dual Wide VCElements

Form VC-504 Sizes 16 to 76

Section B

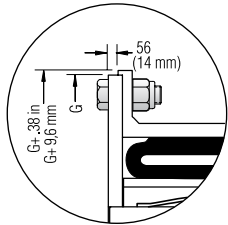

Construction for sizes 66 thru 76

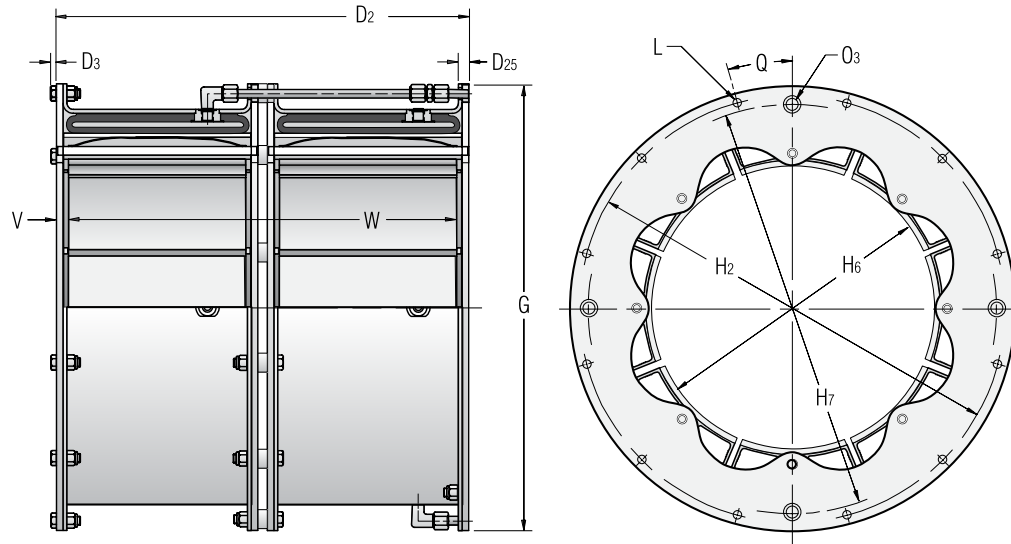

ENGLISH

Size	Part Number	M _t Torque Rating lb·in@ 75 psi	Max. Speed (rpm)	C _s Centrifugal Loss (psi/rpm ²)	Wk ² (lb·ft ²)	Weight (lb)	Friction Area (in ²)	Friction New	Lining Thickness (ins) Worn	AirTube Cavity (in ³)	Minimum Drum Diameter (ins)
16VC1000	142122	228,000	1400	27 E-06	380	430	940	0.32	0.16	510	15.91
20VC1000	142123	322,000	1300	37 E-06	618	568	1270	0.32	0.16	620	19.87
24VC1000	142124	438,000	1250	46 E-06	1104	756	1440	0.44	0.16	930	23.87
28VC1000	142125	592,000	1100	55 E-06	1652	862	1680	0.44	0.16	1060	27.81
32VC1000	142126	830,000	1050	63 E-06	3140	1248	1920	0.57	0.38	1200	31.81
38VC1200	142127	1,360,000	740	82 E-06	4660	1368	2720	0.57	0.38	1510	37.81
42VC1200	142128	1,638,000	670	86 E-06	7340	1790	3000	0.57	0.38	1700	41.75
46VC1200	142129	1,900,000	600	108 E-06	9660	1960	3180	0.68	0.38	2410	45.75
52VC1200	142131	2,430,000	550	127 E-06	14570	2384	3580	0.68	0.38	3020	51.75
51VC1600	142130	3,220,000	550	125 E-06	21160	3868	4760	0.66	0.30	4000	50.75
60VC1600	142132	4,366,000	520	145 E-06	41064	4900	5600	0.66	0.30	4700	59.75
66VC1600	142198	5,600,000	480	186 E-06	49700	5260	6160	0.66	0.30	3920	65.75
76VC1600	146509	7,300,000	416	241 E-06	72940	5970	6940	0.66	0.30	4800	75.75
76VC2000	146531	9,300,000	275	146 E-06	82084	6700	8390	0.66	0.30	4963	75.75

Size	Part Number	M _t Torque Rating N·m@ 5,2 bar	Max. Speed (rpm)	C _s Centrifugal Loss (bar/rpm ²)	J (kg·m ²)	Mass (kg)	Friction Area (cm ²)	Friction New	Lining Thickness (mm) Worn	AirTube Cavity (dim ³)	Minimum Drum Diameter (mm)
16VC1000	142122	25,760	1400	1,86 E-06	15,96	195	6063	8	4	8,36	404
20VC1000	142123	36,380	1300	2,55 E-06	25,96	257	8192	8	4	10,2	505
24VC1000	142124	49,490	1250	3,17 E-06	46,37	342	9288	11	4	15,3	606
24VC1000	142125	66,890	1100	3,80 E-06	69,38	390	10836	11	4	17,4	706
32VC1000	142126	93,780	1050	4,35 E-06	131,9	565	12384	14	10	19,7	808
38VC1200	142127	153,660	740	5,66 E-06	195,7	620	17544	14	10	24,8	960
42VC1200	142128	185,070	670	5,93 E-06	308,3	811	19350	14	10	27,9	1060
46VC1200	142129	214,670	600	7,45 E-06	405,7	888	20516	17	10	39,5	1162
52VC1200	142131	274,550	550	8,76 E-06	611,9	1080	23097	17	10	49,5	1314
51VC1600	142130	363,810	550	8,63 E-06	888,7	1752	30702	17	8	65,6	1289
60VC1600	142132	493,290	520	10,01 E-06	1725	2220	36120	17	8	77,1	1518
66VC1600	142198	632,710	480	12,83 E-06	2087	2383	39732	17	8	64,3	1670
76VC1600	146509	827,050	416	16,66 E-06	3074	2705	45150	17	8	79,0	1924
76VC2000	146531	1,050,760	275	10,06 E-06	3461	3038	54128	17	8	81,7	1924

Airflex® Dual Wide VCElements

Form VC-504 Sizes 16 to 76

Section B

ENGLISH

(Dimensions in inches)

Size	D ₂	D ₃	D ₂₅	G	H ₂	H ₆	H ₇	L No.	L Dia	O ₃ No.	O ₃ Size	Q (Deg)	V	W No.	W Width
16VC1000	23.69	0.31	0.63	25.500	24.375	16.22	24.38	12	0.500	4	0.38	15.00	0.78	16	22.13
20VC1000	23.69	0.31	0.63	29.500	28.375	20.22	28.38	12	0.500	4	0.38	15.00	0.78	16	22.13
24VC1000	23.69	0.39	0.63	34.000	32.750	24.22	32.50	16	0.625	4	0.50	11.25	0.78	20	22.13
28VC1000	23.69	0.39	0.63	38.000	36.750	28.22	36.50	16	0.625	4	0.50	11.25	0.78	20	22.13
32VC1000	23.81	0.39	0.63	43.875	42.625	32.22	42.13	24	0.625	4	0.50	7.50	0.81	24	23.19
38VC1200	28.06	0.47	0.66	49.375	47.875	38.22	48.00	20	0.750	4	0.63	9.00	0.88	24	26.31
42VC1200	28.06	0.47	0.66	53.625	52.125	42.22	52.25	24	0.750	4	0.63	7.50	0.88	28	26.31
46VC1200	28.06	0.55	0.75	60.250	58.500	46.25	57.50	24	0.875	4	0.63	7.50	0.88	32	26.31
52VC1200	29.06	0.55	1.13	67.000	65.500	52.25	65.00	32	0.875	4	0.88	5.63	1.13	36	26.81
51VC1600	37.06	0.55	1.13	67.000	65.500	51.25	65.00	32	0.875	4	0.88	5.63	1.13	36	34.81
60VC1600	37.56	0.61	1.38	77.000	75.000	60.43	74.25	36	1.000	4	0.88	5.00	1.25	40	35.06
66VC1600	37.00	0.78	1.38	82.123	79.625	66.22	78.38	40	1.312	4	0.88	4.50	1.25	44	34.50
76VC1600	37.00	0.88	1.38	92.123	89.625	76.72	88.38	48	1.312	4	0.88	3.75	1.25	50	34.50
76VC2000	45.00	0.88	1.38	92.123	89.625	76.72	88.38	48	1.312	4	0.88	3.75	1.25	50	42.56

SI

(Dimensions in millimeters)

Size	D ₂	D ₃	D ₂₅	G	H ₂	H ₆	H ₇	L No.	L Dia	O ₃ No.	O ₃ Size	Q (Deg)	V	W No.	W Width
16VC1000	602	8	16	647,7	619,1	412	619	12	12,7	4	10	15,00	20	16	562
20VC1000	602	8	16	749,3	720,7	514	721	12	12,7	4	10	15,00	20	16	562
24VC1000	602	10	16	863,6	831,9	615	826	16	15,9	4	13	11,25	20	20	562
28VC1000	602	10	16	965,2	933,5	717	927	16	15,9	4	13	11,25	20	20	562
32VC1000	605	10	16	1114,4	1082,7	818	1070	24	15,9	4	13	7,50	21	24	589
38VC1200	713	12	17	1254,1	1216,0	971	1219	20	19,1	4	16	9,00	22	24	668
42VC1200	713	12	17	1362,1	1324,0	1072	1327	24	19,1	4	16	7,50	22	28	668
42VC1200	713	14	19	1530,4	1485,9	1175	1461	24	22,2	4	16	7,50	22	32	668
52VC1200	738	14	29	1701,8	1663,7	1327	1651	32	22,2	4	22	5,63	29	36	681
51VC1600	941	14	29	1701,8	1663,7	1302	1651	32	22,2	4	22	5,63	29	36	884
60VC1600	954	15	35	1955,8	1905,0	1535	1886	36	25,4	4	22	5,00	32	40	891
66VC1600	940	20	35	2085,9	2022,5	1682	1991	40	33,3	4	22	4,50	32	44	876
76VC1600	940	22	35	2339,9	2276,5	1948	2245	48	33,3	4	22	3,75	32	50	876
76VC2000	1143	22	35	2339,9	2276,5	1948	2245	48	33,3	4	22	3,75	32	50	1081

Notes:

Part Number refers to basic part number only. When ordering, the number of air inlets and type of connection must be specified.

M_r — Dynamic torque shown, static torque approximately 25% greater. Torque in each application is dependent upon air pressure and speed.

Tolerance for sizes (G):

16 thru 20
+0.000/-0.005 in

(+0,00/-0,13 mm)

24 thru 28

+0.000/-0.008 in
(+0,00/-0,20 mm)

32 thru 60

+0.000/-0.010 in
(+0,00/-0,25 mm)

66 thru 76

+0.000/-0.005 in
(+0,00/-0,13 mm)

(L) Tolerance:

+0.005/-0.000 in

(+0,13/-0,00 mm)

(O₃) — All sizes available with either two or four outlets.

(Maximum Speed) — Maximum rpm is dependent upon operating conditions and varies for each application. Consult factory for applications exceeding these speeds.

(Air Tube Cavity) — Drum contact with worn shoes.

Airflex®VC Clutch Application

Form VC-529 — Air Bridge Arrangement —

Technical Data — Narrow Sizes 11.5 to 42

Section B

English ④	lb	lb · ft ²	lb	lb · ft ²	lb	lb · ft ²	lb	lb · ft ²
11.5VC500	96	43	46	9	35	2	2	0.3
14VC500	128	78	66	19	65	4	6	1.3
16VC600	151	115	94	35	62	4	14	10.3
20VC600	179	193	139	78	95	9	15	16
24VC650	246	369	178	148	124	19	19	25
28VC650	280	537	231	269	240	59	20	32
33VC650	392	1083	312	486	347	93	19	42
37VC650	433	1400	340	691	398	159	23	56
42VC650	485	1990	424	1100	545	243	24	66

Size	Element		Drum		Drum Hub		Air Bridge	
	Weight	Wk ²	Weight	Wk ²	Weight	Wk ²	Weight	Wk ²
	Mass	J	Mass	J	Mass	J	Mass	J
11.5VC500	43	1,81	21	0,38	16	0,08	1	0,01
14VC500	58	3,28	30	0,80	29	0,17	3	0,05
16VC600	68	4,83	43	1,47	28	0,17	6	0,43
20VC600	81	8,11	63	3,28	43	0,38	7	0,67
24VC650	111	15,50	81	6,22	56	0,80	9	1,05
28VC650	127	22,55	105	11,30	109	2,48	9	1,34
33VC650	178	45,49	141	20,41	157	3,91	9	1,76
37VC650	196	58,80	154	29,02	180	6,68	10	2,35
42VC650	220	83,58	192	46,20	247	10,21	11	2,77
SI ⑤	kg	kg · m ²	kg	kg · m ²	kg	kg · m ²	kg	kg · m ²

Size	Part Numbers			
	Element ⑥	Drum	Drum Hub	Air Bridge
11.5VC500	142639	408290	406960	410546
14VC500	143829	408283	406962	408165
16VC600	142640	408292	406964	407294
20VC600	142641	408294	406966	407307
24VC650	142642	408296	406968	411796
28VC650	142643	409479	406970	400203
33VC650	142644	408300	406972	413799
37VC650	142645	408302	406974	411797
42VC650	142647	408304	407000	411798

Notes:

- ① Refers to basic part number only and does not include the rotorseal and hose. When ordering, the number and type of element connections must be specified.
- ② Dynamic torque shown, static torque approximately 25% greater. Torque in each application is dependent upon air pressure and speed.
- ③ Based upon minimum bores. Rotorseal and hose not included.
- ④ Based upon minimum bores.
- ⑤ Refers to basic part number only. When ordering, the number of air inlets and type of connection must be specified.

Airflex®VC Clutch Application

Form VC-529 — Air Bridge Arrangement —

Dimensional Data — Narrow Sizes 11.5 to 42

Section B

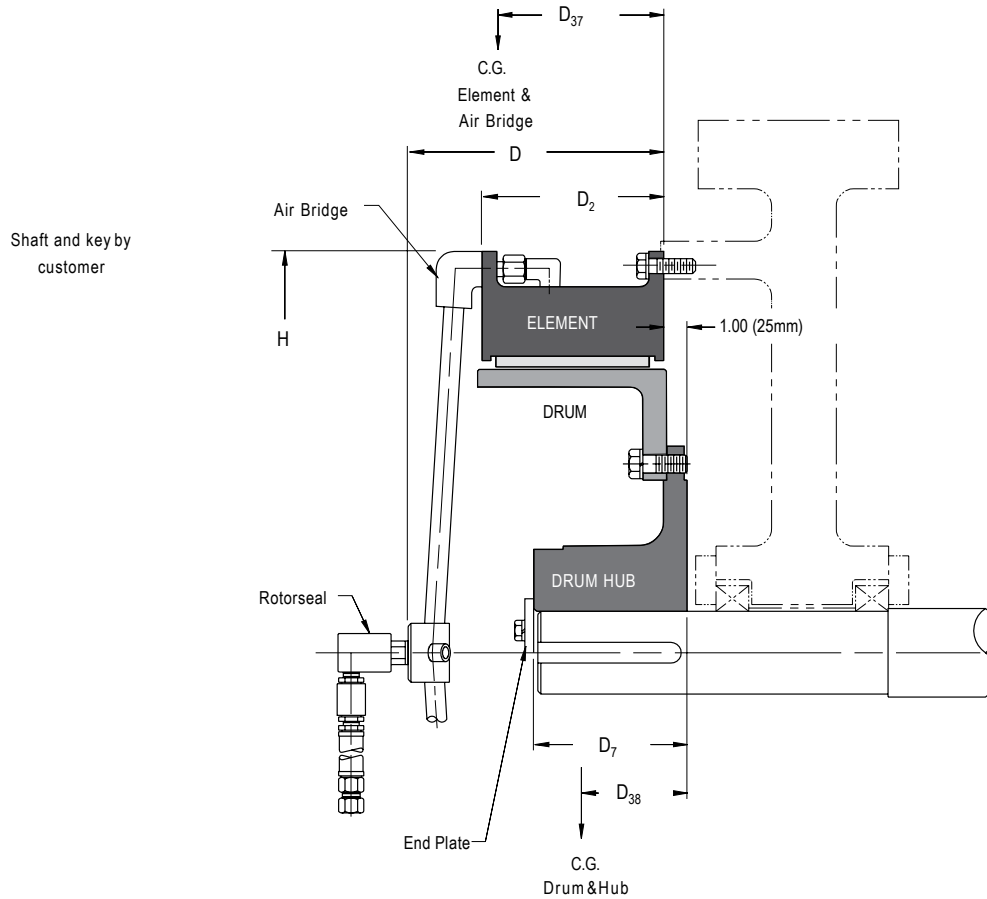

English		lb · in @ 75 psi		lb Ⓟ	Dimensions in inches							
111.5VC500	107040	27000	B3	183	2.50	4.13	10.13	6.13	5.00	3.2	2.9	19.63
14VC500	107041	39200	C2	266	2.75	5.00	9.75	6.13	5.75	3.3	3.3	23.50
16VC600	107042	65000	C2	327	3.25	5.00	11.06	7.38	5.75	4.2	3.4	25.50
20VC600	107043	93000	C2	434	3.75	5.50	11.19	7.38	6.50	4.0	3.4	29.50
24VC650	107044	135000	C2	608	4.25	6.00	11.81	7.69	6.50	4.3	3.0	34.00
28VC650	107045	182000	C2	742	4.75	8.00	11.94	7.69	8.00	4.2	3.2	38.00
33VC650	107046	255000	3/4 RH	1004	5.25	9.50	11.97	7.69	9.00	4.1	3.3	44.63
37VC650	107047	320000	3/4 RH	1128	5.50	9.50	12.25	7.69	9.00	4.2	3.2	48.63
42VC650	107048	380000	3/4 RH	1442	6.00	10.50	12.41	7.69	10.00	4.1	3.4	53.63

Size	Part Number	Torque Rating	Rotorseal Size	Weight Mass	Bore Range		D	D ₂	D ₇	D ₃₇	D ₃₈	H
					Min	Max						
11.5VC500	107040	3050	B3	83	64	105	257	156	127	81	74	499
14VC500	107041	4430	C2	120	70	127	248	156	146	84	84	597
16VC600	107042	7350	C2	148	83	127	281	187	146	107	86	648
20VC600	107043	10500	C2	197	95	140	284	187	165	102	86	749
24VC650	107044	15300	C2	275	108	152	300	195	165	109	76	864
28VC650	107045	20600	C2	336	121	203	303	195	203	107	81	965
33VC650	107046	28800	3/4 RH	455	133	241	304	195	229	104	84	1134
37VC650	107047	36200	3/4 RH	511	140	241	311	195	229	107	81	1235
42VC650	107048	42900	3/4 RH	653	152	267	315	195	254	104	86	1362

SI		N · m @ 5, 2 bar		kg Ⓟ	Dimensions in millimeters						
----	--	---------------------	--	------	---------------------------	--	--	--	--	--	--

Airflex®VC Clutch Application

Form VC-532 — Gap Mounted Arrangement —
 Technical Data — Narrow Sizes 11.5 to 42
 Section B

English Ⓣ	lb	lb · ft ²	lb	lb · ft ²	lb	lb · ft ²	lb	lb · ft ²
11.5VC500	96	43	70	19	83	16	35	2
14VC500	128	78	102	35	139	40	65	4
16VC600	151	115	139	50	175	66	62	4
20VC600	179	193	224	122	234	138	95	9
24VC650	246	369	260	174	293	258	124	19
28VC650	280	537	514	534	348	472	240	59
33VC650	392	1083	716	811	507	827	347	93
37VC650	433	1400	940	1404	553	1172	398	159
42VC650	485	1990	1284	2106	662	1809	545	243

Size	Element		Spider		Drum		Drum Hub	
	Weight	Wk ²	Weight	Wk ²	Weight	Wk ²	Weight	Wk ²
	Mass	J	Mass	J	Mass	J	Mass	J
11.5VC500	43	1,81	32	0,80	38	0,67	16	0,08
14VC500	58	3,28	46	1,47	63	1,68	29	0,17
16VC600	68	4,83	63	2,10	79	2,77	28	0,17
20VC600	81	8,11	101	5,12	106	5,80	43	0,38
24VC650	111	15,50	118	7,31	133	10,84	56	0,80
28VC650	127	22,55	233	22,43	158	19,82	109	2,48
33VC650	178	45,49	324	34,06	230	34,73	157	3,91
37VC650	196	58,80	426	58,97	251	49,22	180	6,68
42VC650	220	83,58	582	88,45	300	75,98	247	10,21
SI Ⓣ	kg	kg · m ²	kg	kg · m ²	kg	kg · m ²	kg	kg · m ²

Size	Part Numbers			
	Element Ⓣ	Spider	Drum	Drum Hub
11.5VC500	142639	408376	408307	406959
14VC500	143829	411170	408309	406961
16VC600	142640	408277	408311	406963
20VC600	142641	408279	410862	406965
24VC650	142642	408281	409804	405625
28VC650	142643	505480	409706	406969
33VC650	142644	505285	410022	406971
37VC650	142645	505275	410866	406973
42VC650	142647	502369	409964	406975

Notes:

- ❶ Refers to basic part number only and does not include the rotor seal and hose. When ordering, the number and type of element connections must be specified.
- ❷ Dynamic torque shown, static torque approximately 25% greater. Torque in each application is dependent upon air pressure and speed.
- ❸ Based upon minimum bores. Rotor seal and hose not included.
- ❹ $M \text{ (in)} = 0,268(H/2 - \text{radius of bore}) + 0,34$
 $M \text{ (mm)} = 0,268(H/2 - \text{radius of bore}) + 8,7$
- ❺ American National Pipe Thread
- ❻ Pipe tap not required. Thru hole diameter 0.44 in (11 mm).
- ❼ Refer to Rotor seal Section for mounting and dimension information.
- ❽ Refer to VC Spider Piping and Configuration catalog page for other sizes.
- ❾ Based upon minimum bores.
- ❿ Refers to basic part number only. When ordering, the number of air inlets and type of connection must be specified.

Airflex®VC Clutch Application

Form VC-532 — Gap Mounted Arrangement —

Dimensional Data — Narrow Sizes 11.5 to 42

Section B

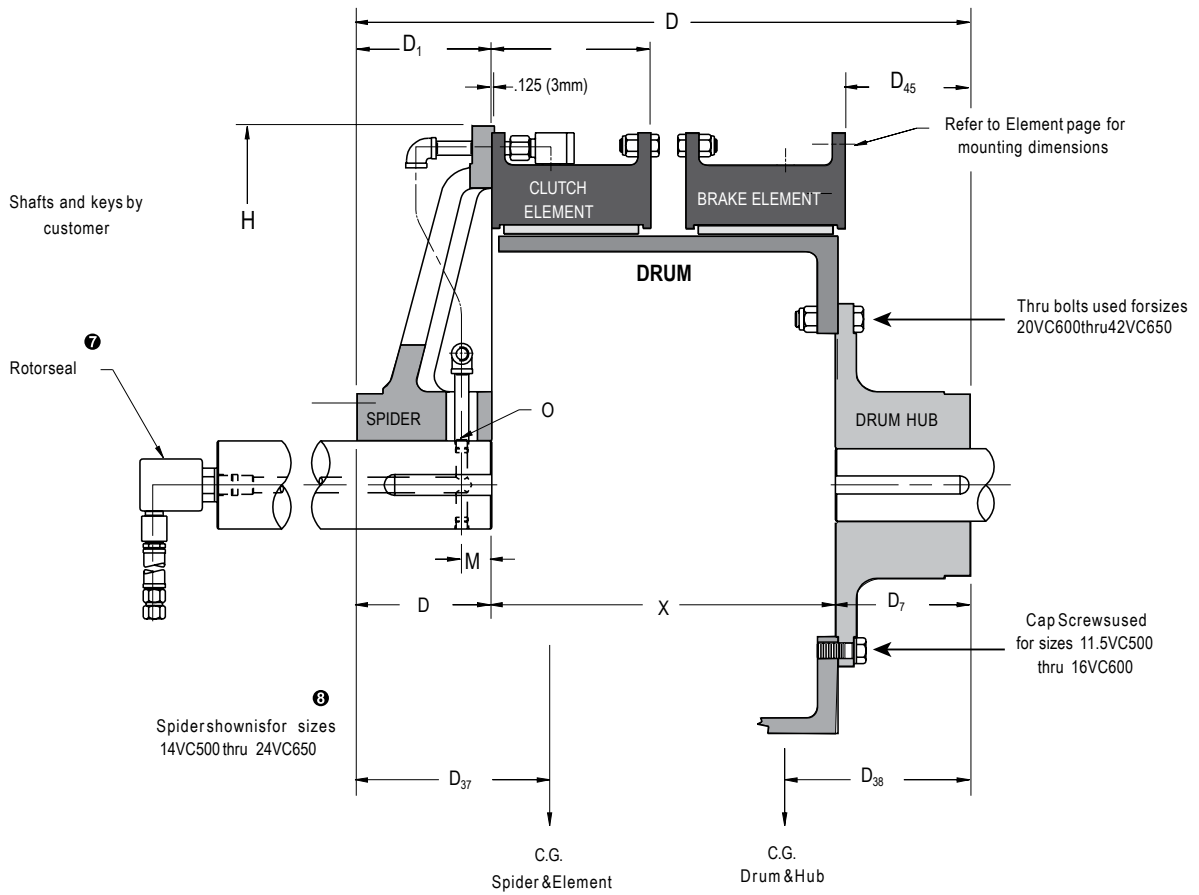

English		lb · in @ 75 psi	lb Ⓞ	Dimensions in inches													
11.5VC500	107594	27000	B3	380	2.50	4.13	22.72	4.34	6.13	5.00	5.3	8.3	4.50	20.00	④	⑥	13.38
14VC500	107595	39200	B3	562	2.75	5.00	24.69	5.50	6.13	5.75	6.0	8.7	5.19	24.00	1.44	3/8-18	13.44
16VC600	107596	65000	B3	678	3.25	5.00	27.19	5.50	7.38	5.75	6.2	9.8	5.19	26.00	1.44	3/8-18	15.94
20VC600	107597	93000	C2	911	3.75	5.50	28.44	6.00	7.38	6.50	6.0	10.0	5.94	30.00	1.44	3/8-18	
24VC650	107598	135000	C2	1169	4.25	6.00	29.69	6.50	7.69	6.50	6.6	10.4	5.94	34.63	1.44	3/8-18	
28VC650	107599	182000	C2	1662	4.75	8.00	32.69	8.00	7.69	8.00	6.9	10.7	7.45	38.63	5.00	1/2-14	16.69
33VC650	107600	255000	3/4 RH	2354	5.25	9.50	34.75	9.00	7.69	9.00	7.5	11.3	8.45	45.25	5.00	1/2-14	16.75
37VC650	107774	320000	3/4 RH	2757	5.50	9.50	35.75	10.00	7.69	9.00	7.9	11.3	8.45	49.25	6.00	1/2-14	16.75
42VC650	107775	380000	3/4 RH	3461	6.00	10.50	37.75	11.00	7.69	10.00	8.2	11.7	9.45	54.25	6.00	1/2-14	16.75

Size	Part Number	M _r Torque Rating	Rotorseal Size	Weight		Bore Range	D	D ₁	D ₂	D ₇	D ₃₇	D ₃₈	D ₄₅	H	M	O Ⓞ	X
				Mass													
11.5VC500	107594	3050	B3	172		Min 64 Max. 105	577	110	156	127	135	211	114	508	④		340
14VC500	107595	4430	B3	255		Min 70 Max. 127	627	140	156	146	152	221	132	610	37	3/8-18	
16VC600	107596	7350	B3	307		Min 83 Max. 341	691	140	187	146	157	249	132	660	37	3/8-18	
20VC600	107597	10500	C2	413		Min 95 Max. 405	722	152	187	165	152	254	151	762	37	3/8-18	
24VC650	107598	15300	C2	530		Min 108 Max. 495	754	165	195	165	168	264	151	880	37	3/8-18	424
28VC650	107599	20600	C2	753		Min 121 Max. 203	830	203	195	203	175	272	189	981	127	1/2-14	424
33VC650	107600	28800	3/4 RH	1066		Min 133 Max. 241	883	229	195	229	191	287	215	1149	127	1/2-14	425
37VC650	107774	36200	3/4 RH	1249		Min 140 Max. 241	908	254	195	229	201	287	215	1251	152	1/2-14	425
42VC650	107775	42900	3/4 RH	1568		Min 152 Max. 267	959	279	195	254	208	297	240	1378	152	1/2-14	425

SI		N · m @ 5, 2 bar	kg Ⓞ	Dimensions in millimeters												
----	--	---------------------	------	---------------------------	--	--	--	--	--	--	--	--	--	--	--	--

Airflex®VC Brake Application

Form VC-526 — Technical Data — Narrow Sizes 11.5 to 42

Section B

English ③	lb	lb	lb · ft ²	lb	lb · ft ²
11.5VC500	96	46	9	35	2
14VC500	128	66	19	65	4
16VC600	151	94	35	62	4
20VC600	179	139	78	95	9
24VC650	246	178	148	124	19
28VC650	280	231	269	240	59
33VC650	392	312	486	347	93
37VC650	433	340	691	398	159
42VC650	485	424	1100	545	243

Size	Element		Drum		Drum Hub	
	Weight	Weight	Wk ²	Weight	Wk ²	
	Mass	Mass	J	Mass	J	
11.5VC500	43	21	0,38	16	0,08	
14VC500	58	30	0,80	29	0,17	
16VC600	68	43	1,47	28	0,17	
20VC600	81	63	3,28	43	0,38	
24VC650	111	81	6,22	56	0,80	
28VC650	127	105	11,30	109	2,48	
33VC650	178	141	20,41	157	3,91	
37VC650	196	154	29,02	180	6,68	
42VC650	220	192	46,20	247	10,21	
SI ④	kg	kg	kg · m ²	kg	kg · m ²	

Size	Part Numbers		
	Element ①	Drum	Hub
11.5VC500	142639	408290	406960
14VC500	143829	408283	406962
16VC600	142640	408292	406964
20VC600	142641	408294	406966
24VC650	142642	408296	415398
28VC650	142643	409479	406970
33VC650	142644	408300	406972
37VC650	142645	408302	406974
42VC650	142647	408304	407000

Notes:

- ① Refers to basic part number only. When ordering, the number of air inlets and type of connection must be specified.
- ② Dynamic torque shown, static torque approximately 25% greater. Torque in each application is dependent upon air pressure and speed.
- ③ Based upon minimum bores.
- ④ Tolerance for sizes:
 11.5 thru 20 +0.000/-0.005 in (+0,00/-0,13 mm)
 24 thru 28 +0.000/-0.008 in (+0,00/-0,20 mm)
 33 thru 42 +0.000/-0.010 in (+0,00/-0,13 mm)

Airflex®VC Brake Application

Form VC-526— Dimensional Data — Narrow Sizes 11.5 to 4242

Section B

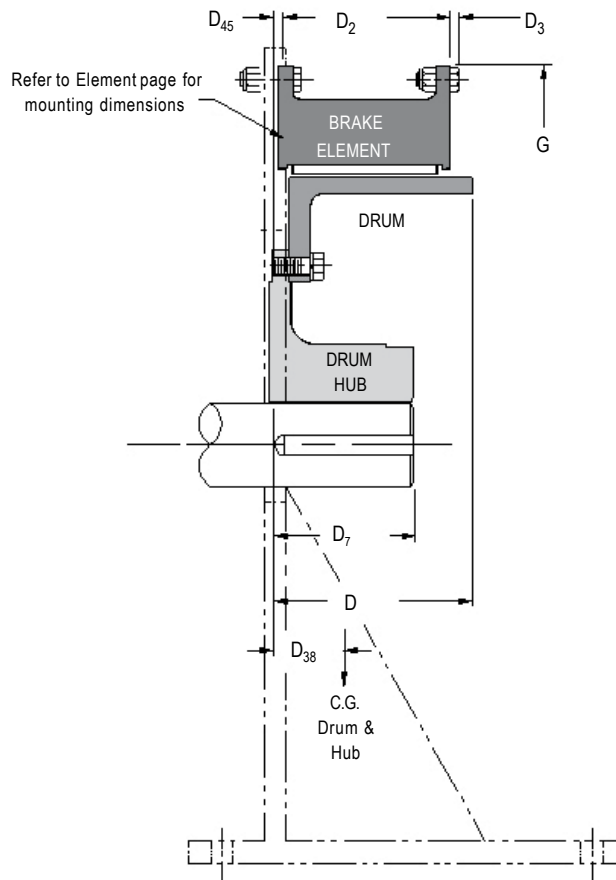

English		lb · in @ 75 psi	lb ⌀	Dimensions in inches							
11.5VC500	105861	27000	177	2.50	4.13	7.25	6.13	5.00	2.9	0.94	19.625
14VC500	105862	39200	259	2.75	5.00	7.38	6.13	5.75	3.1	1.07	23.500
16VC600	105863	65000	307	3.25	5.00	8.50	7.38	5.75	3.3	0.94	25.500
20VC600	105864	93000	413	3.75	5.50	8.63	7.38	6.50	3.2	1.06	29.500
24VC650	105865	135000	548	4.25	6.00	9.13	7.69	6.50	3.2	1.16	34.000
28VC650	105866	182000	751	4.75	8.00	9.13	7.69	8.00	3.2	1.16	38.000
33VC650	105867	255000	1051	5.25	9.50	9.13	7.69	9.00	3.5	1.16	44.625
37VC650	105868	320000	1171	5.50	9.50	9.13	7.69	9.00	3.2	1.16	48.625
42VC650	105869	380000	1454	6.00	10.50	9.13	7.69	10.00	3.4	1.16	53.625

Size	⌀ Part Number	⌀ M. Torque Rating	Weight Mass	Bore Range		D	D ₂	D ₇	D ₃₈	D ₄₅	⌀ G
				Min	Max						
11.5VC500	105861	3050	80	64	105	184	156	127	74	24	498,5
14VC500	105862	4430	117	70	127	187	156	146	79	27	596,9
16VC600	105863	7350	139	83	127	216	187	146	84	24	647,7
20VC600	105864	10500	187	95	140	219	187	165	81	27	749,3
24VC650	105865	15300	248	108	152	232	195	165	81	29	863,6
28VC650	105866	20600	340	121	203	232	195	203	81	29	965,2
33VC650	105867	28800	476	133	241	232	195	229	89	29	1133,5
37VC650	105868	36200	530	140	241	232	195	229	81	29	1235,1
42VC650	105869	42900	659	152	267	232	195	254	86	29	1362,1

SI		N · m @ 5, 2 bar	kg ⌀	Dimensions in millimeters							
----	--	---------------------	------	---------------------------	--	--	--	--	--	--	--

Airflex®VC Brake Application

Form VC-538 — Technical Data — Wide Sizes 14 to 66

Section B

English ③	lb	lb	lb · ft²	lb	lb · ft²
14VC1000	213	122	35	70	5
16VC1000	240	98	38	106	10
20VC1000	282	169	112	173	23
24VC1000	378	225	192	243	47
28VC1000	431	295	350	332	88
32VC1000	624	371	559	450	133
38VC1200	684	552	1214	600	253
42VC1200	895	582	1567	780	430
46VC1200	980	729	2357	950	690
52VC1200	1192	852	3552	1212	1138
51VC1600	1934	890	4145	1961	2167
60VC1600	2450	1640	8810	2604	3270
66VC1600	2630	1905	19360	4940	6760

Size	Element		Drum		Drum Hub	
	Weight	Weight	Wk²	Weight	Wk²	
	Mass	Mass	J	Mass	J	
14VC1000	96	55	1,47	32	0,21	
16VC1000	109	44	1,60	48	0,42	
20VC1000	128	77	4,70	78	0,97	
24VC1000	171	102	8,06	110	1,97	
28VC1000	195	134	14,70	150	3,70	
32VC1000	283	168	23,48	204	5,59	
38VC1200	310	250	50,99	272	10,63	
42VC1200	405	264	65,81	353	18,06	
46VC1200	444	330	98,99	430	28,98	
52VC1200	540	386	149,2	549	47,80	
51VC1600	876	403	174,1	888	91,01	
60VC1600	1110	743	370,0	1180	137,3	
66VC1600	1191	863	813,1	2238	283,9	
SI ④	kg	kg	kg · m²	kg	kg · m²	

Size	Part Numbers		
	Element ①	Drum	Drum Hub
14VC1000	142838	411111	411113
16VC1000	142821	409506	407069
20VC1000	142832	410087	407073
24VC1000	142675	409794	405625
28VC1000	142674	409537	405628
32VC1000	142673	410824	405631
38VC1200	142739	409474	405634
42VC1200	142677	409947	405637
46VC1200	142671	409980	405640
52VC1200	142841	409715	407079
51VC1600	142835	409711	408585
60VC1600	142915	411501	411500
66VC1600	142097	413727	

Notes:

- ① Refers to basic part number only. When ordering, the number of air inlets and type of connection must be specified.
- ② Dynamic torque shown, static torque approximately 25% greater. Torque in each application is dependent upon air pressure and speed.
- ③ Based upon minimum bores.
- ④ Tolerance for sizes:
 14 thru 20 +0.000/-0.005 in (+0,00/-0,13 mm)
 24 thru 28 +0.000/-0.008 in (+0,00/-0,20 mm)
 32 thru 60 +0.000/-0.010 in (+0,00/-0,25 mm)
 66 +0.000/-0.005 in (+0,00/-0,13 mm)

Airflex®VC Brake Application

Form VC-538 — Dimensional Data — Wide Sizes 14 to 66

Section B

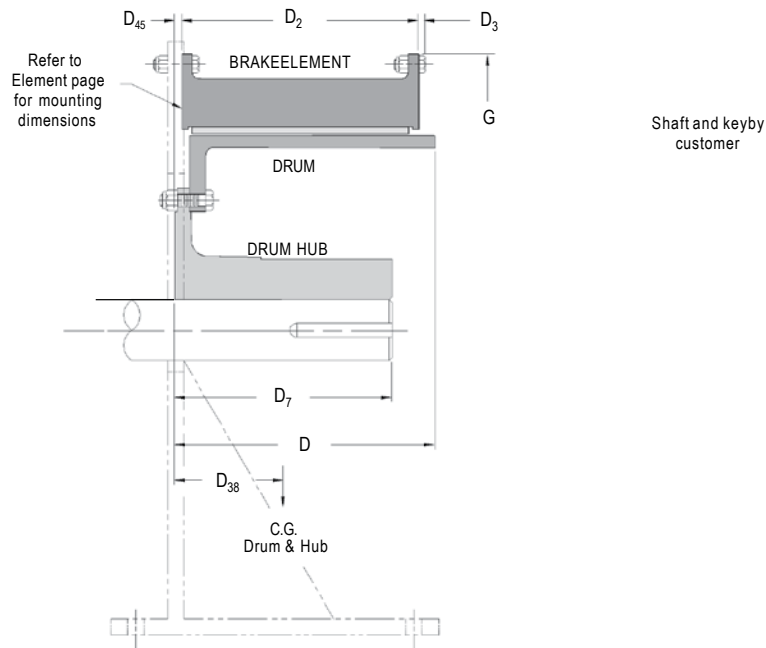

English		lb · in @ 75 psi	lb ⌀	Dimensions in inches							
14VC1000	107601	85000	405	3.63	5.00	12.38	11.56	7.00	5.0	0.75	23.500
16VC1000	107602	114000	444	3.88	6.00	12.38	11.56	5.50	3.9	0.75	25.500
20VC1000	107603	161000	624	4.50	6.25	12.38	11.56	7.00	4.3	0.75	29.500
24VC1000	107604	219000	846	5.00	8.00	12.63	11.56	7.50	4.4	1.00	34.000
28VC1000	107605	296000	1058	5.50	8.50	12.63	11.56	8.00	4.4	1.00	38.000
32VC1000	107606	415000	1445	6.00	9.00	12.63	11.63	9.50	4.6	1.00	43.875
38VC1200	107607	680000	1836	7.25	9.25	14.75	13.75	10.00	5.1	1.00	49.375
42VC1200	107608	819000	2257	7.50	10.00	14.75	13.75	11.00	5.0	1.00	53.625
46VC1200	107609	950000	2659	8.00	10.00	15.00	13.75	11.00	5.0	1.25	60.250
52VC1200	107610A	1215000	3256	8.75	11.00	15.25	14.25	12.50	5.1	1.25	67.000
51VC1600	107611	1610000	4785	9.50	12.50	19.50	18.25	15.00	6.7	1.25	67.000
60VC1600	107612	2183000	6694	10.50	18.00	19.63	18.50	16.00	6.9	1.50	77.000
66VC1600	107613	2800000	9475	11.25	18.50	20.38	18.50	20.00	8.7	2.00	82.123

Size	Part Number	M _r Torque Rating	Weight Mass	Bore Range		D	D ₂	D ₇	D ₃₈	D ₄₅	G
				Min	Max						
14VC1000	107601	9610	183	92	127	314	294	178	127	19	596,9
16VC1000	107602	12900	201	99	152	314	294	140	99	19	647,7
20VC1000	107603	18200	283	114	159	314	294	178	109	19	749,3
24VC1000	107604	24700	383	127	203	321	294	191	112	25	863,6
28VC1000	107605	33400	479	140	216	321	294	203	112	25	965,2
32VC1000	107606	46900	655	152	229	321	295	241	117	25	1114,4
38VC1200	107607	76800	832	184	235	375	349	254	130	25	1254,1
42VC1200	107608	92500	1022	191	254	375	349	279	127	25	1362,1
46VC1200	107609	107000	1205	203	254	381	349	279	127	32	1530,4
52VC1200	107610A	137000	1475	222	279	387	362	318	130	32	1701,8
51VC1600	107611	182000	2168	241	318	495	464	381	170	32	1701,8
60VC1600	107612	247000	3032	267	457	499	470	406	175	38	1955,8
66VC1600	107613	316000	4292	286	470	518	470	508	221	51	2085,9

SI		N · m @ 5, 2 bar	kg ⌀	Dimensions in millimeters							
----	--	---------------------	------	---------------------------	--	--	--	--	--	--	--

Airflex® VC Clutch Application

Form VC-506 Single Narrow Series

Section B

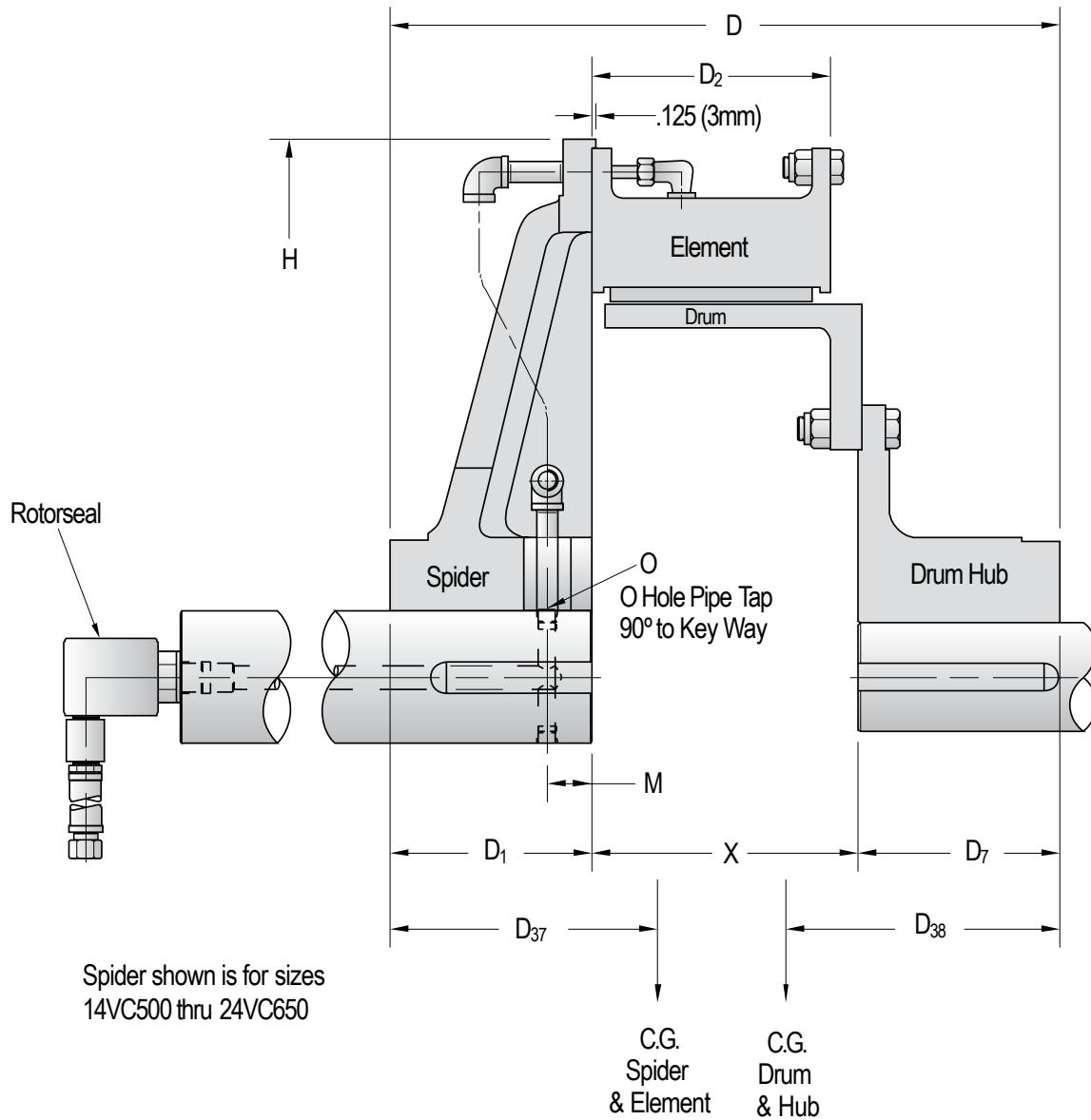

Airflex®VC Clutch Application

Form VC-506 Single Narrow Series

Section B

English				Bore Range (inches)			
Size	Basic B/M	Torque Rating (lb-ins) at 75 PSI	Weight (lbs)	Spider Min.	Spider Max.	Hub Min.	Hub Max.
11.5VC500	104601	27,000	247	2.500	4.125	2.500	4.125
14VC500	104602	39,200	362	2.750	5.000	2.750	5.000
16VC600	104603	65,000	446	3.250	5.000	3.250	5.000
20VC600	104604	93,000	637	3.750	5.500	3.750	5.500
24VC650	104605	135,000	828	4.250	6.000	4.250	6.000
28VC650	104606	182,000	1265	4.750	8.000	4.750	8.000
33VC650	104607	255,000	1767	5.250	9.500	5.250	9.500
37VC650	104608	320,000	2111	5.500	9.500	5.500	9.500
42VC650	104609	380,000	2738	6.000	10.500	6.000	10.500

SI				Bore Range (millimeters)			
Size	Basic B/M	Torque Rating (N-m) at 5,2 bar	Mass (kg)	Spider Min.	Spider Max.	Hub Min.	Hub Max.
11.5VC500	104601	3,050	112	64	105	64	105
14VC500	104602	4,430	164	70	127	70	127
16VC600	104603	7,340	202	83	127	83	127
20VC600	104604	10,505	289	95	140	95	140
24VC650	104605	15,250	375	108	152	108	152
28VC650	104606	20,560	573	121	203	121	203
33VC650	104607	28,810	800	133	241	133	241
37VC650	104608	36,155	956	140	241	140	241
42VC650	104609	42,930	1241	152	267	152	267

English (Dimensions in inches)											Clearance for "Drop Out"	
Size	D	D ₁	D ₂	D ₇	D ₃₇	D ₃₈	H	M	O	X	Element	Drum
11.5VC500	16.09	4.344	6.125	5.000	5.3	5.5	20.000	1	2	6.750	.27	.12
14VC500	18.06	5.500	6.125	5.750	6.0	5.8	24.000	1.438	3/8-18 NPT	6.812	.25	.19
16VC600	19.31	5.500	7.375	5.750	6.2	6.5	26.000	1.438	3/8-18 NPT	8.062	.25	.19
20VC600	20.56	6.000	7.375	6.500	6.0	6.9	30.000	1.438	3/8-18 NPT	8.062	.25	.19
24VC650	21.56	6.500	7.688	6.500	6.6	7.2	34.625	1.438	3/8-18 NPT	8.562	.36	.19
28VC650	24.56	8.000	7.688	8.000	6.9	7.9	38.625	5.000	1/2-14 NPT	8.562	.36	.19
33VC650	26.56	9.000	7.688	9.000	7.5	8.3	45.250	5.000	1/2-14 NPT	8.562	.28	.19
37VC650	27.56	10.000	7.688	9.000	7.9	8.4	49.250	6.000	1/2-14 NPT	8.562	.28	.19
42VC650	29.56	11.000	7.688	10.000	8.2	9.0	54.250	6.000	1/2-14 NPT	8.562	.28	.19

SI (Dimensions in millimeters)											Clearance for "Drop Out"	
Size	D	D ₁	D ₂	D ₇	D ₃₇	D ₃₈	H	M	O	X	Element	Drum
11.5VC500	409	110	156	127	135	140	508	1	2	171	6,8	3,1
14VC500	459	140	156	146	152	147	610	37	3/8-18 NPT	173	6,3	4,8
16VC600	490	140	187	146	157	165	660	37	3/8-18 NPT	205	6,3	4,8
20VC600	522	152	187	165	152	175	762	37	3/8-18 NPT	205	6,3	4,8
24VC650	548	165	195	165	168	183	880	37	3/8-18 NPT	217	9,1	4,8
28VC650	624	203	195	203	175	201	981	127	1/2-14 NPT	217	9,1	4,8
33VC650	675	229	195	229	191	211	1149	127	1/2-14 NPT	217	7,1	4,8
37VC650	700	254	195	229	201	213	1251	152	1/2-14 NPT	217	7,1	4,8
42VC650	751	279	195	254	208	229	1378	152	1/2-14 NPT	217	7,1	4,8

1 M(in)=0.268 (H/2-radius of bore) +0.34 M(mm)=0,268 (H/2-radius of bore) +8,7

2 Pipe tap not required. Thru hole diameter 0.44 in (11 mm).

Ventilated Adapter Arrangement

Technical Data

Form VC507 — Dual Narrow Sizes 11.5 to 42

Section B

English	lb	bf	lb	bf	lb	bf	lb	bf	lb	bf
11.5VC500	197	86	73	35	64	4	83	16	43	2
14VC500	258	156	103	70	74	8	139	40	60	4
16VC600	307	230	130	108	108	15	175	66	82	6
20VC600	363	386	146	167	166	34	234	138	124	13
24VC650	497	738	194	297	250	68	293	258	215	42
28VC650	565	1074	219	424	324	119	348	472	292	85
33VC650	784	2166	259	686	532	342	507	827	395	123
37VC650	871	2800	321	1026	595	360	553	1172	528	240
42VC650	980	3980	378	1550	769	608	662	1809	647	413
Size	Weight	Wk ²	Weight	Wk ²	Weight	Wk ²	Weight	Wk ²	Weight	Wk ²
	Element		VentilatedAdapter		AdapterHub		Drum		DrumHub	
	Mass	J	Mass	J	Mass	J	Mass	J	Mass	J
11.5VC500	89	3,61	33	1,47	29	0,17	38	0,67	19	0,08
14VC500	117	6,55	47	2,94	34	0,33	63	1,68	27	0,17
16VC600	139	9,66	59	4,54	49	0,63	79	2,77	37	0,25
20VC600	164	16,21	66	7,01	75	1,43	106	5,80	56	0,55
24VC650	225	31,00	88	12,47	113	2,86	133	10,84	97	1,76
28VC650	256	45,11	99	17,81	147	5,00	158	19,82	132	3,57
33VC650	355	90,97	117	28,81	241	14,36	230	34,73	179	5,17
37VC650	395	117,6	145	43,09	270	15,12	251	49,22	239	10,08
42VC650	444	167,2	171	65,10	348	25,54	300	75,98	293	17,35
SI	kg	kg.m ²	kg	kg.m ²	kg	kg.m ²	kg	kg.m ²	kg	kg.m ²

Size	PartNumbers				
	Element	VentilatedAdapter	AdapterHub	Drum	DrumHub
11.5VC500	142112	406949	408232	408307	406945
14VC500	142114	406950	408234	408309	406961
16VC600	142115	505030	408236	408311	407027
20VC600	142116	504974	408238	408313	406376
24VC650	142117	504975	408240	411828	405625
28VC650	142118	504976	408242	408317	405628
33VC650	142119	504977	408244	408319	405631
37VC650	142120	504978	408246	408321	405634
42VC650	142121	504979	408248	408323	405637

Notes:

Refer to basic part number only and does not include the rotor seal and hose. When ordering, the number and type of element connections must be specified.

Dynamic torque shown, static torque approximately 25% greater. Torque in each application is dependent upon air pressure and speed.

Based upon minimum bores. Rotor seal and hose not included.

American National Pipe Thread. Shaft to adapter pipings similar to that shown on VC Spider Pipe and Configuration catalog page.

Refer to Rotor Seal Section for mounting and dimension information.

Based upon minimum bores.

Refer to basic part number only. When ordering, the number of air inlets and type of connection must be specified.

Through hole in adapter hub is normally not provided. If required, the dimension is 3.00 in (76,2 mm)

Ventilated Adapter Arrangement

Dimensional Data

Form VC507 — Dual Narrow Sizes 11.5 to 42

Section B

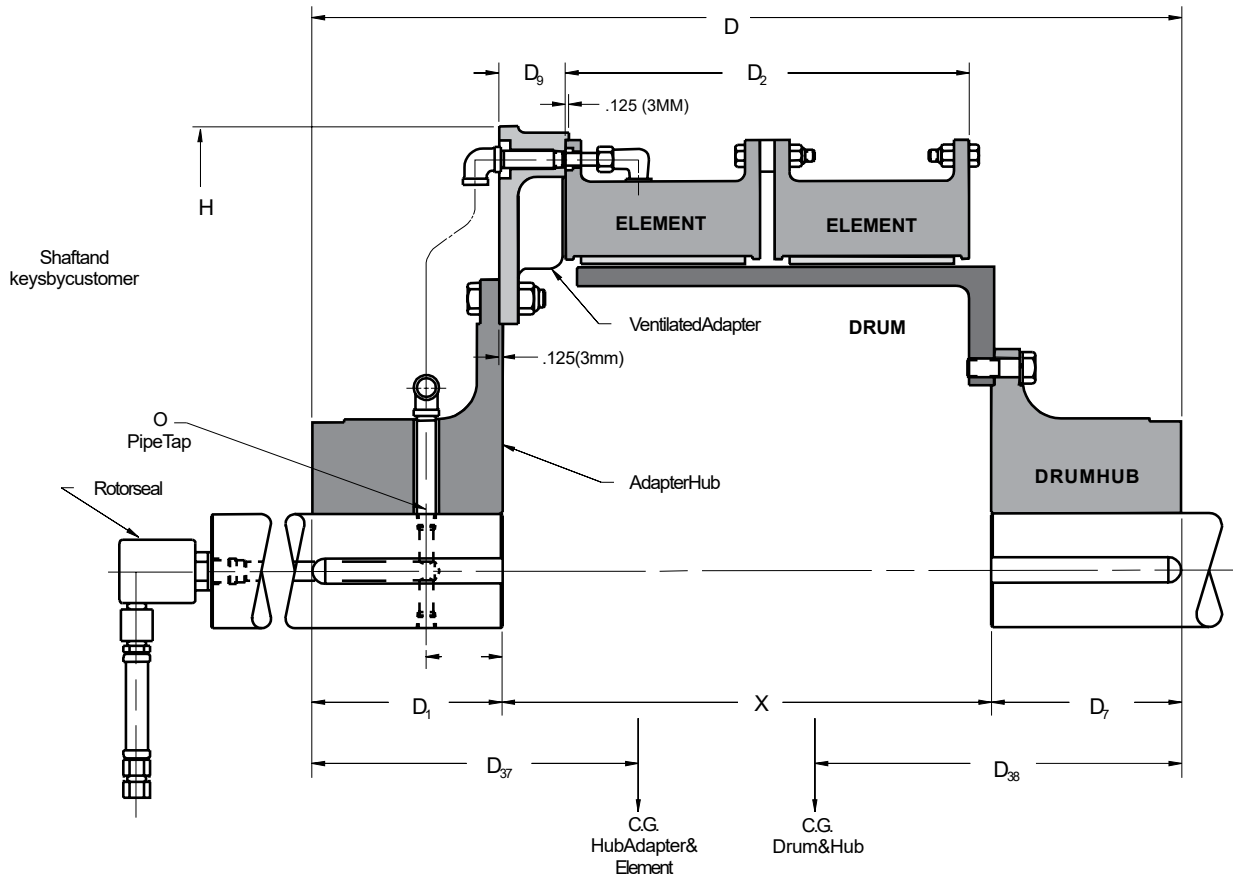

English	Part Number	bh @ 75psi	lb	Dimensions in inches											No. Size		X
Size	Part Number	M _t Torque Rating	Rotor Seal Size	Weight Mass	Min. Bore	Max. Bore	D	D ₁	D ₂	D ₇	D ₉	D ₃₇	D ₃₈	H	O	No. Size	X
11.5VC500	104298	5 4 0 0 0 C	2 4 6 0 3	.004	.002	.28	7.55	7.75	12.75	7.00	2.75	10.99	4.20	3.82	1 1/4	- 1 8 16	.00
14VC500	105435	7 8 4 0 0 C	2 6 3 4 3	.504	.75	27.50	5.75	12.69	5.75	2.75	11.08	9.24	6.32	2 1/2	- 1 4 16	.00	
16VC600	105436	1 3 0 0 0 0 C	2 8 0 2 4	.255	.003	31.56	6.50	15.19	6.50	2.75	12.49	8.26	6.32	2 1/2	- 1 4 18	.56	
20VC600	104299	1 8 6 0 0 0 C	2 1 0 3 3 4	.756	.003	32.56	7.00	15.19	7.00	2.75	12.29	7.30	6.32	2 1/2	- 1 4 18	.56	
24VC650	105437	2 7 0 0 0 0 3/4 R H	1 4 4 9 5	.257	.50	34.31	7.50	15.94	7.50	2.75	12.69	7.35	6.32	2 1/2	- 1 4 19	.31	
28VC650	105438	3 6 4 0 0 0 3/4 R H	1 7 4 8 5	.758	.50	35.31	8.00	15.94	8.00	2.75	12.89	9.39	6.32	2 1/2	- 1 4 19	.31	
33VC650	105439	5 1 0 0 0 0 1 R H	2 4 7 7 6	.509	.003	38.38	9.50	15.94	9.50	2.75	13.81	11.04	5.88	2 3/4	- 1 4 19	.38	
37VC650	105440	6 4 0 0 0 0 1 R H	2 8 6 8 7	.009	.50	39.38	10.00	15.94	10.00	2.75	14.21	11.24	5.88	2 3/4	- 1 4 19	.38	
42VC650	105441	7 6 0 0 0 0 1 1/4 R H	3 4 3 6 7	.501	.50	41.38	11.00	15.94	11.00	2.75	14.71	11.55	5.88	2 3/4	- 1 4 19	.38	
11.5VC500	104298	6 1 0 0 0 C	2 2 0 8 7	6 1 0 2 7	3 0 1 4	6 3 2 4	1 7 8	7 0 2 7	6 2 3	9 5 1 8	2 1 1/4	- 1 8 4	0 6				
14VC500	105435	8 8 6 0 0 C	2 2 8 7 8	9 1 2 1 6	9 9 1 4	6 3 2 2	1 4 6	7 0 2 7	9 2 2 6	6 2 6 2	1 1/2	- 1 4 4	0 6				
16VC600	105436	1 4 7 0 0 0 C	2 3 6 3 1	0 8 1 2 7	8 0 2 1 6	5 3 8 6	1 6 5	7 0 3 1	4 2 4	9 6 7 6	2 1 1/2	- 1 4 4	7 1				
20VC600	104299	2 1 0 0 0 0 C	2 4 6 8 1	2 1 1 5	2 8 2 7 1	7 8 3 8 6	1 7 8	7 0 3 0	9 2 4 6	7 7 8 2	1 1/2	- 1 4 4	7 1				
24VC650	105437	3 0 5 0 0 0 3/4 R H	6 5 6 1 3	3 1 9 1 8	7 1 1 9	1 4 0 5	1 9 1 7	0 3 1 9	2 4 6	8 9 2 2	1 1/2	- 1 4 4	9 0				
28VC650	105438	4 1 1 0 0 0 3/4 R H	7 9 2 1 4	6 2 1 6	8 9 7 2 0	3 4 0 5	2 0 3 7	0 3 2 4	2 5 1 9	9 4 2 1	1 1/2	- 1 4 4	9 0				
33VC650	105439	5 7 6 0 0 0 1 R H	1 1 2 2 1 6	5 2 2 9	9 7 5 2 4	1 4 0 5	2 4 1 7	0 3 5 0	2 7 9 1	1 1 6 5	2 3/4	- 1 4 4	9 2				
37VC650	105440	7 2 3 0 0 0 1 R H	1 2 9 9 1 7	8 2 4 1 1	0 0 2 5	4 4 0 5	2 5 4 7	0 3 6 1	2 8 4 1	2 6 7 2	3/4	- 1 4 4	9 2				
42VC650	105441	8 5 9 0 0 0 1 1/4 R H	1 5 5 7 1 9	1 2 6 7	1 0 5 1	2 7 9 4	0 5 2 7	9 7 0 3	7 3 2 9	2 1 3 9	4 2 3/4	- 1 4 4	9 2				
SI	Part Number	Nm @ 5.2 bar	kg	Dimensions in millimeters											No. Size		X

Airflex®VC Clutch Application

Form VC-508 Dual Narrow Series

Section B

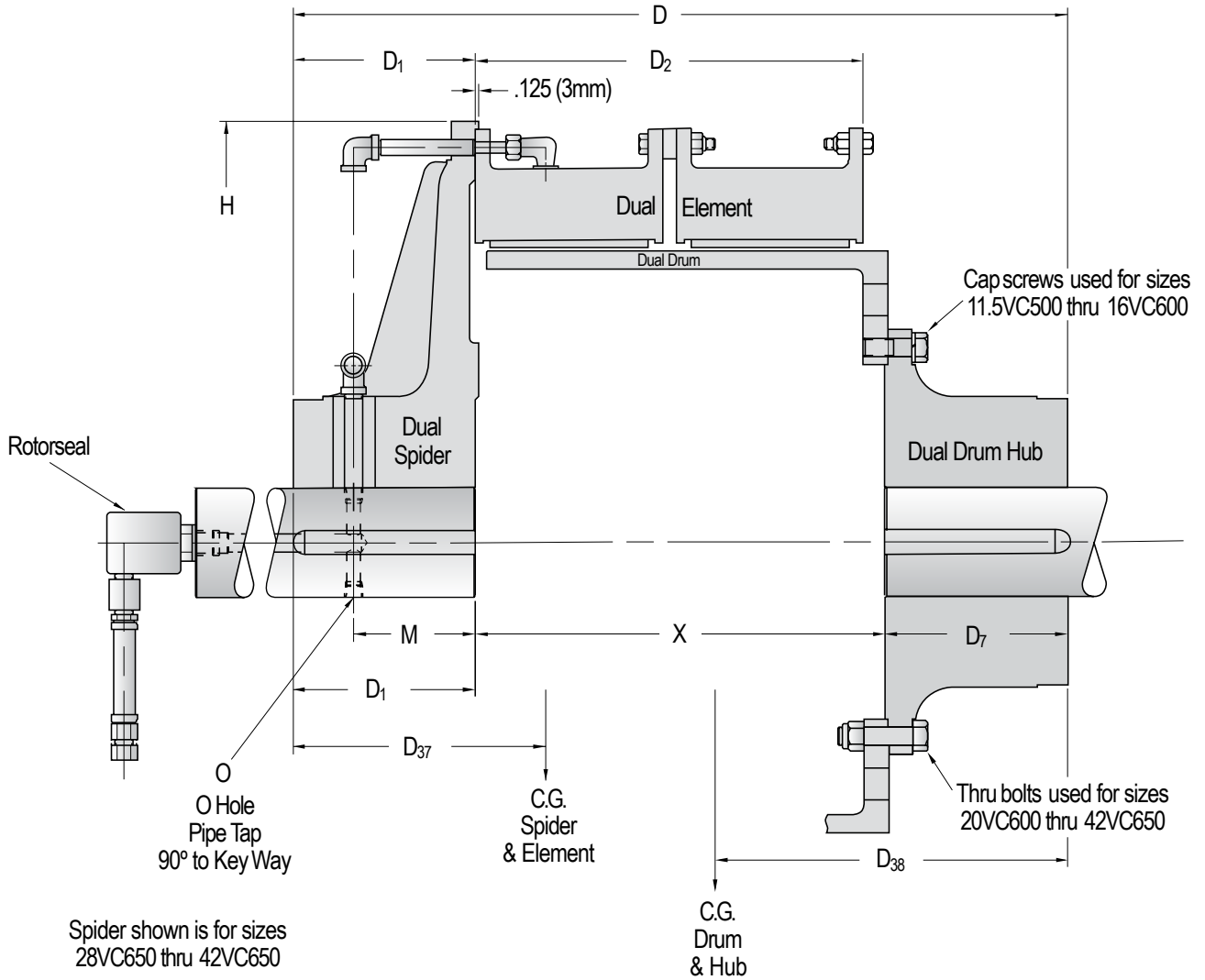

Airflex®VC Clutch Application

Form VC-508 Dual Narrow Series

Section B

ENGLISH				Bore Range (inches)			
Size	Basic B/M	Torque Rating (lb-ins) at 75 PSI	Weight (lbs)	Spider Min.	Spider Max.	Hub Min.	Hub Max.
11.5VC500	104610	54,000	393	3.000	4.000	3.000	4.000
14VC500	104611	78,400	559	3.500	4.750	3.500	4.750
16VC600	104612	130,000	800	4.250	6.000	4.250	5.000
20VC600	104613	186,000	1016	4.750	6.000	4.750	6.000
24VC650	104614	270,000	1413	5.250	7.500	5.250	7.500
28VC650	104615	364,000	1759	5.750	8.500	5.750	8.500
33VC650	104616	510,000	2488	6.500	9.000	6.500	9.000
37VC650	104617	640,000	2933	7.000	9.500	7.000	9.500
42VC650	104618	760,000	3407	7.500	10.500	7.500	10.500

SI				Bore Range (millimeters)			
Size	Basic B/M	Torque Rating (N-m) at 5,2 bar	Mass (kg)	Spider Min.	Spider Max.	Hub Min.	Hub Max.
11.5VC500	104610	6,100	178	76	102	76	102
14VC500	104611	8,860	253	89	121	89	121
16VC600	104612	14,690	362	108	152	108	152
20VC600	104613	21,010	460	121	152	121	152
24VC650	104614	30,500	640	133	191	133	191
28VC650	104615	41,125	797	146	216	146	216
33VC650	104616	57,620	1127	165	229	165	229
37VC650	104617	72,310	1329	178	241	178	241
42VC650	104618	85,870	1543	191	267	191	267

ENGLISH

Size	(Dimensions in inches)										Clearance for Drop Out	
	D	D ₁	D ₂	D ₇	D ₃₇	D ₃₈	H	M	O	X	Element	Drum
11.5VC500	25.22	4.844	12.750	5.000	8.8	9.4	20.000	1	2	13.375	.27	.12
14VC500	24.69	5.500	12.688	5.750	9.2	8.9	24.000	1.438	½-14 NPT	13.438	.31	.19
16VC600	27.94	5.500	15.188	6.500	9.6	9.7	26.000	4.000	½-14 NPT	15.938	.31	.19
20VC600	29.94	7.000	15.188	7.000	10.2	9.7	30.000	5.000	½-14 NPT	15.938	.31	.19
24VC650	31.69	7.500	15.938	7.500	10.1	9.9	34.625	5.000	¾-14 NPT	16.688	.23	.19
28VC650	32.69	8.000	15.938	8.000	10.7	11.0	38.625	5.000	¾-14 NPT	16.688	.23	.19
33VC650	35.25	9.000	15.938	9.500	11.1	11.2	45.250	5.000	¾-14 NPT	16.750	.22	.19
37VC650	36.75	10.000	15.938	10.000	11.8	11.5	49.250	6.000	¾-14 NPT	16.750	.22	.19
42VC650	38.75	11.000	15.938	11.000	8.6	9.8	54.250	6.000	¾-14 NPT	16.750	.22	.19

SI

Size	(Dimensions in millimeters)										Clearance for Drop Out	
	D	D ₁	D ₂	D ₇	D ₃₇	D ₃₈	H	M	O	X	Element	Drum
11.5VC500	641	123	324	127	224	239	508	1	2	340	6,7	3,2
14VC500	627	140	322	146	234	226	610	37	½-14 NPT	341	7,9	4,8
16VC600	710	140	386	165	244	246	660	102	½-14 NPT	405	7,9	4,8
20VC600	760	178	386	178	259	246	762	127	½-14 NPT	405	7,9	4,8
24VC650	805	191	405	191	257	251	880	127	¾-14 NPT	424	5,9	4,8
28VC650	830	203	405	203	272	279	981	127	¾-14 NPT	424	5,9	4,8
33VC650	895	229	405	241	282	284	1149	127	¾-14 NPT	425	5,6	4,8
37VC650	933	254	405	254	300	292	1251	152	¾-14 NPT	425	5,6	4,8
42VC650	984	279	405	279	218	249	1378	152	¾-14 NPT	425	5,6	4,8

1 M(in)=0.268 (H/2-radius of bore) +0.34 M(mm)=0,268 (H/2-radius of bore) +8,7

2 Pipe tap not required. Thru hole diameter 0.44 in (11 mm).

Airflex®VC Clutch Application
 Form VC508 (LA-7132) — Dual Narrow Series
 with Axial Locking Assembly
 Section B

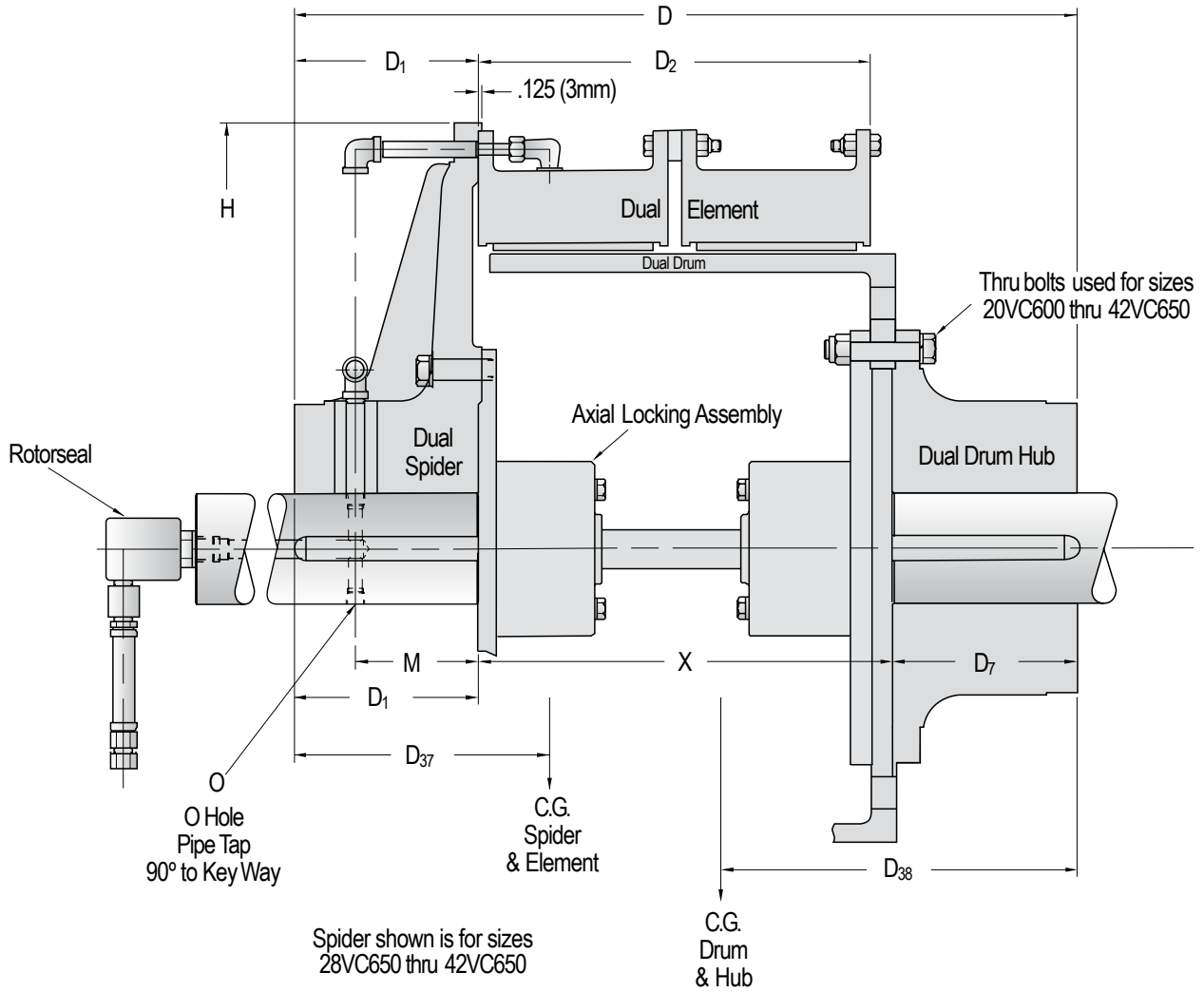

Airflex®VC Clutch Application

Form VC508 (LA-7132) — Dual Narrow Series

with Axial Locking Assembly

Section B

ENGLISH				Bore Range (inches)			
Size	Basic B/M	Torque Rating (lb-ins) at 75 PSI	Weight (lbs)	Spider		Hub	
				Min.	Max.	Min.	Max.
20VC600	104620	186,000	1,126	4.750	6.000	4.750	6.000
24VC650	104621	270,000	1,539	5.250	7.500	5.250	7.500
28VC650	104622	364,000	1,949	5.750	8.500	5.750	8.500
33VC650	104623	510,000	2,655	6.500	9.000	6.500	9.000
37VC650	104624	640,000	3,135	7.000	9.500	7.000	9.500
42VC650	104625	760,000	3,677	7.500	10.500	7.500	10.500

SI				Bore Range (millimeters)			
Size	Basic B/M	Torque Rating (N·m) at 5,2 bar	Mass (kg)	Spider		Hub	
				Min.	Max.	Min.	Max.
20VC600	104620	21,010	511	121	152	121	152
24VC650	104621	30,500	698	133	191	133	191
28VC650	104622	41,120	884	146	216	146	216
33VC650	104623	57,620	1204	165	229	165	229
37VC650	104624	72,310	1422	178	241	178	241
42VC650	104625	85,870	1668	191	267	191	267

ENGLISH											Clearance for "Drop Out" Moving Shafts .250 Apart Locking Assembly and Drum	
Size	(Dimensions in inches)										Element	
	D	D ₁	D ₂	D ₇	D ₃₇	D ₃₈	H	M	O	X		
20VC600	29.94	7.000	15.188	7.000	Consult Factory		30.000	5.000	½-14 NPT	15.938	.12	.56
24VC650	31.69	7.500	15.938	7.500	Consult Factory		34.625	5.000	¾-14 NPT	16.688	.12	.48
28VC650	32.69	8.000	15.938	8.000	Consult Factory		38.625	5.000	¾-14 NPT	16.688	.12	.48
33VC650	35.25	9.000	15.938	9.500	Consult Factory		45.250	5.000	¾-14 NPT	16.750	.12	.47
37VC650	36.75	10.000	15.938	10.000	Consult Factory		49.250	6.000	¾-14 NPT	16.750		.47
42VC650	38.75	11.000	15.938	11.000	Consult Factory		54.250	6.000	¾-14 NPT	16.750		.47

SI											Clearance for "Drop Out" Moving Shafts 6,35 Apart Locking Assembly and Drum	
Size	(Dimensions in millimeters)										Element	
	D	D ₁	D ₂	D ₇	D ₃₇	D ₃₈	H	M	O	X		
20VC600	760	178	386	178	Consult Factory		762	127	½-14 NPT	405	3,2	14,2
24VC650	805	191	405	191	Consult Factory		880	127	¾-14 NPT	424	3,2	12,3
28VC650	830	203	405	203	Consult Factory		981	127	¾-14 NPT	424	3,2	12,3
33VC650	895	229	405	229	Consult Factory		1149	127	¾-14 NPT	425	3,2	11,9
37VC650	933	254	405	254	Consult Factory		1251	152	¾-14 NPT	425	3,2	11,9
42VC650	984	279	405	279	Consult Factory		1378	152	¾-14 NPT	425	3,2	11,9

Airflex®VC Clutch Application

Form VC-509 Single Wide Series

Section B

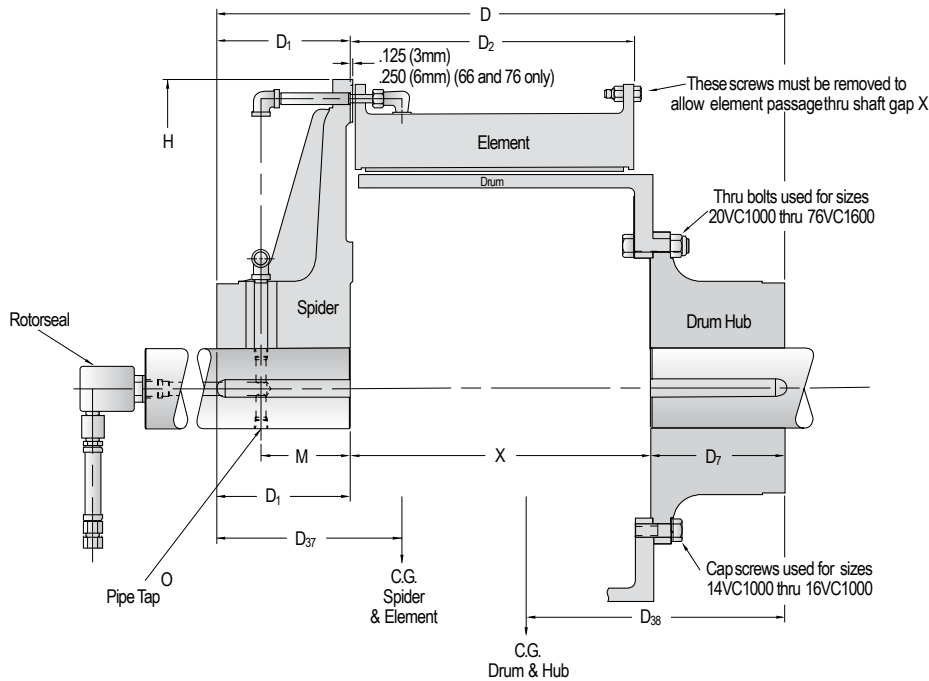

ENGLISH

Size	Basic B/M	Torque Rating (lb·ins) at 75 PSI	Weight (lbs)	Bore Range (inches)		Hub	
				Spider Min.	Max.	Min.	Max.
14VC1000	104979	85,000	610	3.625	5.000	3.625	5.000
16VC1000	104680	114,000	731	3.875	6.000	3.875	6.000
20VC1000	104681	161,000	896	4.500	6.250	4.500	6.250
24VC1000	104682	219,000	1,226	5.000	8.000	5.000	8.000
28VC1000	104683	296,000	1,577	5.500	8.500	5.500	8.500
32VC1000	104684	415,000	2,129	6.000	9.000	6.000	9.000
38VC1200	104685	680,000	2,759	7.250	9.250	7.250	9.250
42VC1200	104686	819,000	3,270	7.500	10.000	7.500	10.000
46VC1200	104687	950,000	4,026	8.000	10.000	8.000	10.000
52VC1200	104688	1,215,000	5,748	8.750	11.000	8.750	11.000
51VC1600	104689	1,610,000	6,920	9.500	12.500	9.500	12.500
60VC1600	104690	2,183,000	10,712	10.500	18.000	10.500	18.000
66VC1600	—	—	Consult Factory	—	—	—	—
76VC1600	—	—	Consult Factory	—	—	—	—

SI

Size	Basic B/M	Torque Rating (N·m) at 5,2 bar	Mass (kg)	Bore Range (millimeters)		Hub	
				Spider Min.	Max.	Min.	Max.
14VC1000	104979	9605	276	92	127	92	127
16VC1000	104680	12880	331	98	152	98	152
20VC1000	104681	18,190	406	114	159	114	159
24VC1000	104682	24,745	555	127	203	127	203
28VC1000	104683	33,445	714	140	216	140	216
32VC1000	104684	46,890	965	152	229	152	229
38VC1200	104685	76,830	1250	184	235	184	235
42VC1200	104686	92,535	1482	191	254	191	254
46VC1200	104687	107,335	1824	203	254	203	254
52VC1200	104688	137,275	2604	222	279	222	279
51VC1600	104689	181,905	3135	241	318	241	318
60VC1600	104690	246,645	4854	267	457	267	457
66VC1600	—	—	Consult Factory	—	—	—	—
76VC1600	—	—	Consult Factory	—	—	—	—

Airflex®VC Clutch Application

Form VC-509 Single Wide Series

Section B

ENGLISH

Size	D	(Dimensions in inches)						H	M	O	X	Clearance for "Drop Out"	
		D ₁	D ₂	D ₇	D ₃₇	D ₃₈	Element					Drum	
14VC1000	24.38	5.500	11.562	7.000	7.0	8.8	24.000	4.000	3/8-18 NPT	11.875	.19	.25	
16VC1000	22.88	5.500	11.562	5.500	6.7	6.6	26.000	4.000	3/8-18 NPT	11.875	.19	.25	
20VC1000	25.88	7.000	11.562	7.000	7.5	8.1	30.000	5.000	3/8-18 NPT	11.875	.19	.25	
24VC1000	26.88	7.500	11.562	7.500	7.9	8.3	34.625	5.000	1/2-14 NPT	11.875	.19	.25	
28VC1000	27.88	8.000	11.562	8.000	8.0	8.7	38.625	5.000	1/2-14 NPT	11.875	.19	.25	
32VC1000	30.44	9.000	11.625	9.500	9.1	9.6	44.500	5.000	1/2-14 NPT	11.938	.19	.31	
38VC1200	34.12	10.000	13.750	10.000	9.5	10.6	50.000	6.000	1/2-14 NPT	14.125	.25	.38	
42VC1200	36.12	11.000	13.750	11.000	10.6	11.0	54.250	6.000	1/2-14 NPT	14.125	.25	.38	
46VC1200	36.12	11.000	13.750	11.000	10.0	11.3	61.000	6.000	1/2-14 NPT	14.125	.25	.38	
52VC1200	39.62	12.500	14.250	12.500	10.3	12.3	67.750	7.000	3/4-14 NPT	14.625	.25	.62	
51VC1600	48.88	15.000	18.250	15.000	13.9	14.3	67.750	7.000	3/4-14 NPT	18.875	.50	.62	
60VC1600	50.75	16.000	18.500	16.000	14.2	15.2	77.750	7.000	1"-11 1/2 NPT	18.750	.12	.88	

SI

Size	D	(Dimensions in millimeters)						H	M	O	X	Clearance for "Drop Out"	
		D ₁	D ₂	D ₇	D ₃₇	D ₃₈	Element					Drum	
14VC1000	619	140	294	178	178	224	610	102	3/8-18 NPT	302	4,8	6,3	
16VC1000	581	140	294	140	170	168	660	102	3/8-18 NPT	302	4,8	6,3	
20VC1000	657	178	294	178	191	206	762	127	3/8-18 NPT	302	4,8	6,3	
24VC1000	683	191	294	191	201	211	880	127	1/2-14 NPT	302	4,8	6,3	
28VC1000	708	203	294	203	203	221	981	127	1/2-14 NPT	302	4,8	6,3	
32VC1000	773	229	295	241	231	244	1130	127	1/2-14 NPT	303	4,8	7,9	
38VC1200	867	254	349	254	241	269	1270	152	1/2-14 NPT	359	6,3	9,5	
42VC1200	918	279	349	279	269	279	1378	152	1/2-14 NPT	359	6,3	9,5	
46VC1200	918	279	349	279	254	287	1549	152	1/2-14 NPT	359	6,3	9,5	
52VC1200	1007	318	362	318	262	312	1721	178	3/4-14 NPT	372	6,3	15,9	
51VC1600	1242	381	464	381	353	363	1721	178	3/4-14 NPT	480	12,7	15,9	
60VC1600	1289	406	470	406	361	386	1975	178	1"-11 1/2 NPT	476	3,2	22,2	

Airflex®VC Clutch Application

Form VC509 (LA-7134) — Single Wide Series

with Axial Locking Assembly

Section B

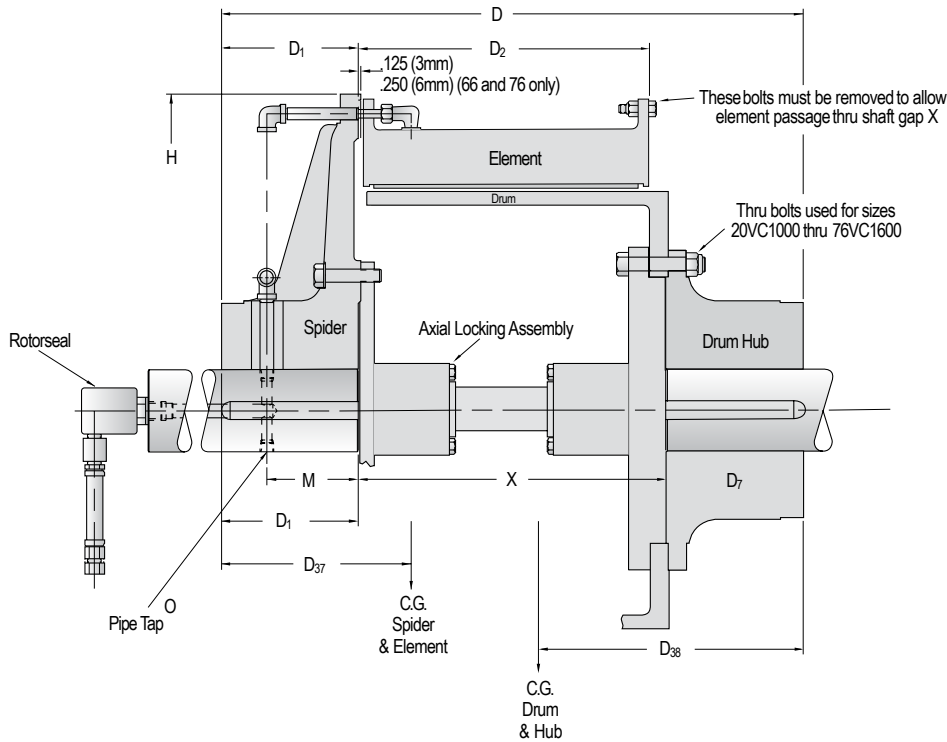

ENGLISH				Bore Range (inches)			
Size	Basic B/M	Torque Rating (lb-ins) at 75 PSI	Weight (lbs)	Spider Min.	Spider Max.	Hub Min.	Hub Max.
20VC1000	104700	161,000	1,006	4.500	6.250	4.500	6.250
24VC1000	104701	219,000	1,345	5.000	8.000	5.000	8.000
28VC1000	104702	296,000	1,714	5.500	8.500	5.500	8.500
32VC1000	104703	415,000	2,279	6.000	9.000	6.000	9.000
38VC1200	104704	680,000	2,964	7.250	9.250	7.250	9.250
42VC1200	104705	819,000	3,506	7.500	10.000	7.500	10.000
46VC1200	104706	950,000	4,302	8.000	10.000	8.000	10.000
52VC1200	104707	1,215,000	5,997	8.750	11.000	8.750	11.000
51VC1600	104708	1,610,000	7,233	9.500	12.500	9.500	12.500
60VC1600	104709	2,183,000	11,315	10.500	18.000	10.500	18.000

SI				Bore Range (millimeters)			
Size	Basic B/M	Torque Rating (N-m) at 5,2 bar	Spider Mass (kg)	Hub Min.	Hub Max.	Min.	Max.
20VC1000	104700	18,190	456	114	159	114	159
24VC1000	104701	24,745	610	127	203	127	203
28VC1000	104702	33,445	777	140	216	140	216
32VC1000	104703	46,890	1034	152	229	152	229
38VC1200	104704	76,830	1344	184	235	184	235
42VC1200	104705	92,535	1590	191	254	191	254
46VC1200	104706	107,335	1951	203	254	203	254
52VC1200	104707	137,275	2217	222	279	222	279
51VC1600	104708	181,905	3227	241	318	241	318
60VC1600	104709	246,645	5127	267	457	267	457

Airflex®VC Clutch Application

Form VC509 (LA-7134) — Single Wide Series

with Axial Locking Assembly

Section B

ENGLISH

Size	(Dimensions in inches)						H	M	O	X	Clearance for "Drop Out" Moving Shafts .250 Apart Locking Assembly	Element
	D	D ₁	D ₂	D ₇	D ₃₇	D ₃₈						
20VC1000	25.88	7.000	11.562	7.000	Consult Factory	30.000	5.000	3/8-18 NPT	11.875	.12	.44	
24VC1000	26.88	7.500	11.562	7.500	Consult Factory	34.625	5.000	1/2-14 NPT	11.875	.12	.44	
28VC1000	27.88	8.000	11.562	8.000	Consult Factory	38.625	5.000	1/2-14 NPT	11.875	.12	.44	
32VC1000	30.44	9.000	11.625	9.500	Consult Factory	44.500	5.000	1/2-14 NPT	11.938	.12	.44	
38VC1200	34.12	10.000	13.750	10.000	Consult Factory	50.000	6.000	1/2-14 NPT	14.125		.50	
42VC1200	36.12	11.000	13.750	11.000	Consult Factory	54.250	6.000	1/2-14 NPT	14.125		.50	
46VC1200	36.12	11.000	13.750	11.000	Consult Factory	61.000	6.000	1/2-14 NPT	14.125		.50	
52VC1200	39.62	12.500	14.250	12.500	Consult Factory	67.750	7.000	3/4-14 NPT	14.625		.50	
51VC1600	48.88	15.000	18.250	15.000	Consult Factory	67.750	7.000	3/4-14 NPT	18.875		.75	
60VC1600	50.75	16.000	18.500	16.000	Consult Factory	77.750	7.000	1"-11 1/2 NPT	18.750		.38	

SI

Size	(Dimensions in millimeters)						H	M	O	X	Clearance for "Drop Out" Moving Shafts 6,35 Apart Locking Assembly	Element
	D	D ₁	D ₂	D ₇	D ₃₇	D ₃₈						
20VC1000	657	178	294	178	Consult Factory	762	127	3/8-18 NPT	302	3,1	11,1	
24VC1000	683	191	294	191	Consult Factory	880	127	1/2-14 NPT	302	3,1	11,1	
28VC1000	708	203	294	203	Consult Factory	981	127	1/2-14 NPT	302	3,1	11,1	
32VC1000	773	229	295	241	Consult Factory	1130	127	1/2-14 NPT	303	3,1	11,1	
38VC1200	867	254	349	254	Consult Factory	1270	152	1/2-14 NPT	359	3,1	12,7	
42VC1200	918	279	349	279	Consult Factory	1378	152	1/2-14 NPT	359	3,1	12,7	
46VC1200	918	279	349	279	Consult Factory	1549	152	1/2-14 NPT	359	3,1	12,7	
52VC1200	1007	318	362	318	Consult Factory	1721	178	3/4-14 NPT	372	3,1	12,7	
51VC1600	1242	381	464	381	Consult Factory	1721	178	3/4-14 NPT	480	3,1	19,1	
60VC1600	1289	406	470	406	Consult Factory	1975	178	1"-11 1/2 NPT	476	3,1	9,5	

Airflex®VC Clutch Application

Form VC-510 Dual Wide Series

Section B

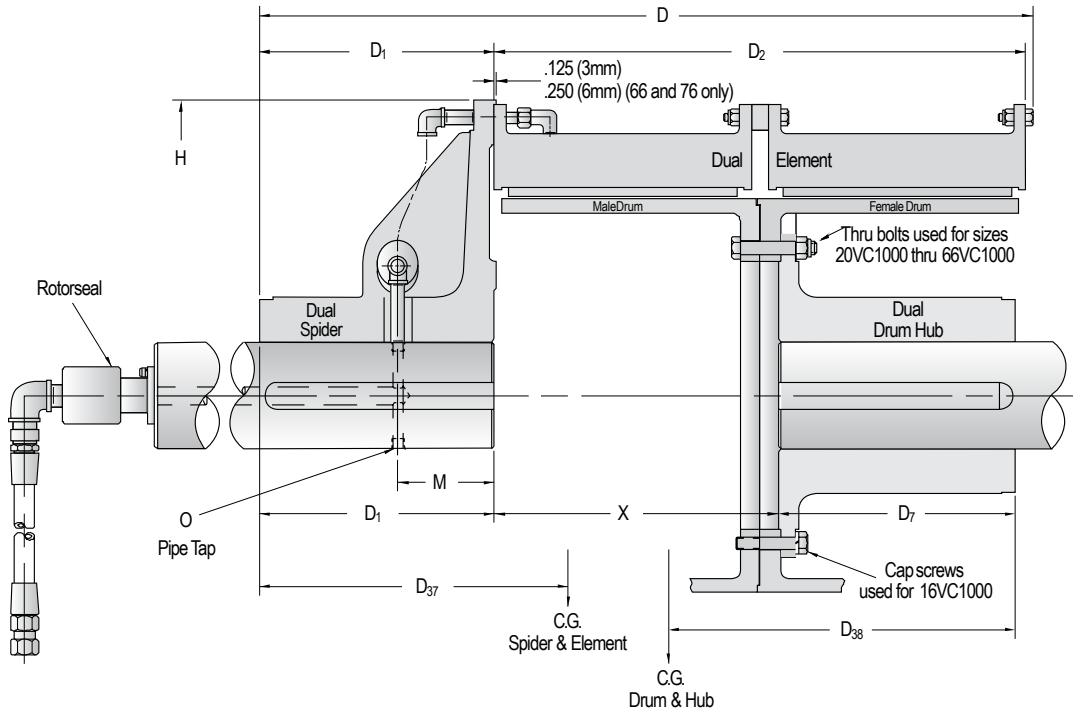

ENGLISH

Size	Basic B/M	Torque Rating (lb.-ins) at 75 PSI	Weight (lbs)	Bore Range (inches)			
				Spider		Hub	
				Min.	Max.	Min.	Max.
16VC1000	104720	228,000	1,085	5.000	6.000	5.000	6.000
20VC1000	104721	322,000	1,440	5.500	6.500	5.500	6.500
24VC1000	104722	438,000	1,910	6.250	7.250	6.250	7.250
28VC1000	104723	592,000	2,490	6.750	8.000	6.750	8.000
32VC1000	104724	830,000	3,510	7.750	10.500	7.750	10.500
38VC1200	104725	1,360,000	4,610	9.000	11.000	9.000	11.000
42VC1200	104726	1,638,000	5,920	9.500	11.750	9.500	11.750
46VC1200	104727	1,900,000	6,560	10.000	12.500	10.000	12.500
52VC1200	104728	2,430,000	8,715	10.750	14.000	10.750	14.000
51VC1600	104729	3,220,000	11,560	12.000	15.500	12.000	15.500
60VC1600	104730	4,366,000	17,675	13.250	20.000	13.250	20.000
66VC1600	Consult Factory	5,600,000	22,960	15.000	22.000	15.000	22.000
76VC1600	Consult Factory	7,320,000	27,450	16.250	24.000	16.250	24.000
76VC2000	Consult Factory	9,300,000	30,255	16.250	24.000	16.250	24.000

SI

Size	Basic B/M	Torque Rating (N·m) at 5,2 bar	Mass (kgs)	Bore Range (millimeters)			
				Spider		Hub	
				Min.	Max.	Min.	Max.
16VC1000	104720	25,760	492	127	152	127	152
20VC1000	104721	36,380	652	140	165	140	165
24VC1000	104722	49,490	865	159	184	159	184
28VC1000	104723	66,890	1,128	172	203	172	203
32VC1000	104724	93,780	1,590	197	267	197	267
38VC1200	104725	153,660	2,088	229	279	229	279
42VC1200	104726	185,070	2,682	241	299	241	299
46VC1200	104727	214,670	2,972	254	318	254	318
52VC1200	104728	274,550	3,948	273	356	273	356
51VC1600	104729	363,810	5,237	305	394	305	394
60VC1600	104730	493,290	8,007	337	508	337	508
66VC1600	Consult Factory	632,710	10,401	381	559	381	559
76VC1600	Consult Factory	827,050	12,438	413	610	413	610
76VC2000	Consult Factory	1,05,0759	13,723	413	610	413	610

Airflex® VC Clutch Application

Form VC-510 Dual Wide Series

Section B

ENGLISH

Size	D	D ₁	D ₂	D ₇	D ₃₇	D ₃₈	H	M	O	X	Clearance Element	"Drop Out" Drum
16VC1000	32.00	8.000	23.688	10.000	14.0	13.8	26.000	4.000	½-14 NPT	12.750	.19	.25
20VC1000	33.59	9.500	23.688	9.500	15.3	14.8	30.000	5.000	½-14 NPT	12.750	.19	.25
24VC1000	33.39	9.312	23.688	9.500	15.1	15.0	34.625	5.000	¾-14 NPT	12.750	.19	.25
28VC1000	34.08	10.000	23.688	10.000	14.5	15.3	38.625	5.000	¾-14 NPT	12.750	.19	.25
32VC1000	36.20	12.000	23.812	12.000	16.5	15.9	44.500	5.000	¾-14 NPT	12.812	.19	.31
38VC1200	41.53	13.000	28.062	13.000	17.0	18.0	50.000	6.000	¾-14 NPT	15.000	.25	.38
42VC1200	45.53	17.000	28.062	17.000	20.0	19.7	54.250	6.000	¾-14 NPT	15.125	.25	.38
46VC1200	45.61	17.000	28.062	17.000	20.3	20.8	61.000	6.000	¾-14 NPT	15.250	.25	.38
52VC1200	46.61	17.000	29.062	17.000	19.5	19.9	67.750	7.000	1"-11 ½ NPT	15.750	.25	.63
51VC1600	57.61	20.000	37.062	20.000	27.0	23.0	67.750	7.000	1"-11 ½ NPT	20.000	.50	.63
60VC1600	62.17	24.000	37.562	24.000	27.8	26.0	77.750	7.000	1¼-11 ½ NPT	20.375	.12	.88
66VC1600	70.00	CF	37.000	24.000	31.5	22.0	82.500	Consult Factory	1¼-11 ½ NPT	22.000	.25	.63
76VC1600	74.38	26.750	37.000	27.000	27.6	20.0	93.000	11.630	1¼-11 ⅝ NPT	20.370	.38	.88
76VC2000	78.39	26.750	27.000	24.020	30.8	20.7	93.000	11.630	1¼-11 ½ NPT	24.370	.38	.88

SI

Size	D	D ₁	D ₂	D ₇	D ₃₇	D ₃₈	H	M	O	X	Clearance Element	"Drop Out" Drum
16VC1000	813	203	602	254	356	351	660	102	½-14 NPT	324	4,8	6,3
20VC1000	853	241	602	241	389	376	762	127	½-14 NPT	324	4,8	6,3
24VC1000	848	236	602	241	384	381	880	127	¾-14 NPT	324	4,8	6,3
28VC1000	866	254	602	254	368	389	981	127	¾-14 NPT	324	4,8	6,3
32VC1000	919	305	605	305	419	404	1130	127	¾-14 NPT	325	4,8	7,9
38VC1200	1055	330	713	330	432	457	1270	152	¾-14 NPT	381	6,3	9,5
42VC1200	1156	432	713	432	508	500	1378	152	¾-14 NPT	384	6,3	9,5
46VC1200	1158	432	713	432	516	528	1549	152	¾-14 NPT	387	6,3	9,5
52VC1200	1184	432	738	432	495	505	1721	178	1"-11 ½ NPT	400	6,3	15,9
51VC1600	1463	508	941	508	686	584	1721	178	1"-11 ½ NPT	508	12,7	15,9
60VC1600	1579	610	954	610	706	660	1975	178	1¼-11 ½ NPT	518	3,2	22,2
66VC1600	1778	610	940	610	800	559	2096	229	1¼-11 ½ NPT	559	6,3	15,9
76VC1600	1889	680	940	686	701	508	2362	296	1¼-11 ⅝ NPT	517	9,5	22,2
76VC2000	1991	680	1143	686	782	526	2362	295	1¼-11 ½ NPT	619	9,5	22,2

Airflex®VC Clutch Application

Form VC510(LA-7136) — Dual Wide Series

with Axial Locking Assembly

Section B

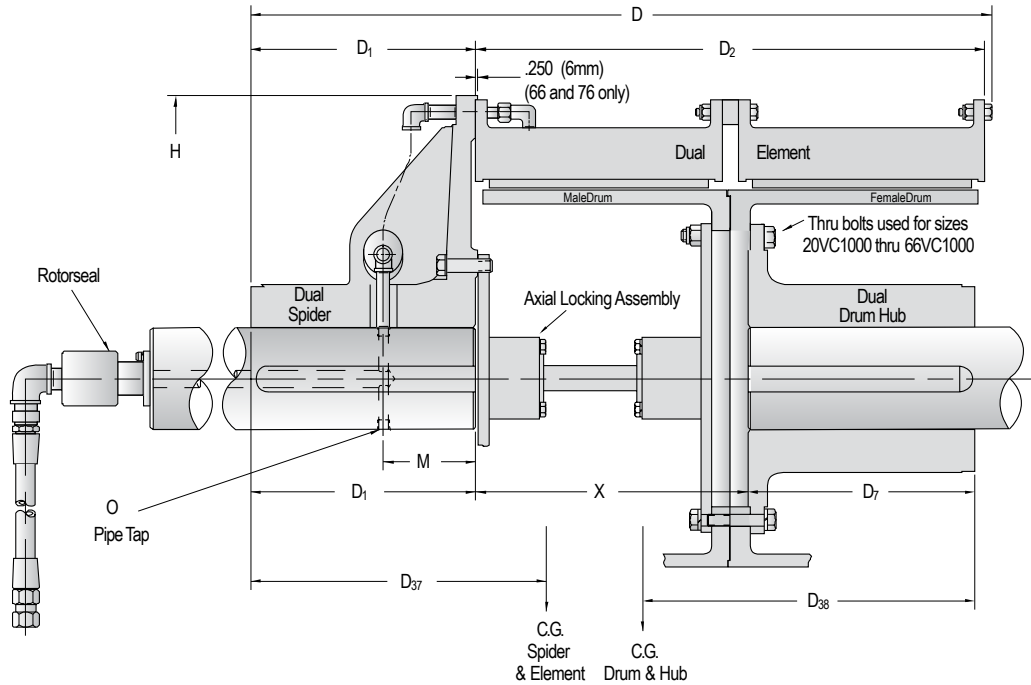

ENGLISH				Bore Range (inches)			
Size	Basic B/M	Torque Rating (lb-ins) at 75 PSI	Weight (lbs)	Spider Min.	Spider Max.	Hub Min.	Hub Max.
20VC1000	104740	322,000	1,577	5.500	6.500	5.500	6.500
24VC1000	104741	438,000	2,071	6.250	7.250	6.250	7.250
28VC1000	104742	592,000	2,641	6.750	8.000	6.750	8.000
32VC1000	104743	830,000	3,775	7.750	10.500	7.750	10.500
38VC1200	104744	1,360,000	4,790	9.000	11.000	9.000	11.000
42VC1200	104745	1,638,000	6,095	9.500	11.750	9.500	11.750
46VC1200	104746	1,900,000	6,754	10.000	12.500	10.000	12.500
52VC1200	104747	2,430,000	9,178	10.750	14.000	10.750	14.000
51VC1600	104748	3,220,000	12,095	12.000	15.500	12.000	15.500
60VC1600	104749	4,366,000	18,855	13.250	20.000	13.250	20.000
66VC1600	108002	5,600,000	23,054	15.000	22.000	15.000	22.000
76VC1600	108082	7,320,000	27,750	16.250	24.000	16.250	24.000
76VC2000	108120	9,300,000	30,565	16.250	24.000	16.250	24.000

SI				Bore Range (millimeters)			
Size	Basic B/M	Torque Rating (N-m) at 5,2 bar	Mass (kgs)	Spider Min.	Spider Max.	Hub Min.	Hub Max.
20VC1000	104740	36,380	715	140	165	140	165
24VC1000	104741	49,490	939	159	184	159	184
28VC1000	104742	66,890	1198	172	203	172	203
32VC1000	104743	93,780	1710	197	267	197	267
38VC1200	104744	153,660	2170	229	279	229	279
42VC1200	104745	185,070	2762	241	299	241	299
46VC1200	104746	214,670	3060	254	318	254	318
52VC1200	104747	274,550	4158	273	356	273	356
51VC1600	104748	363,810	5480	305	394	305	394
60VC1600	104749	493,290	8543	337	508	337	508
66VC1600	106972	632,710	10445	381	559	381	559
76VC1600	108082	827,050	12574	413	610	413	610
76VC2000	108120	1,050,760	13,864	413	610	413	610

Airflex®VC Clutch Application

Form VC510(LA-7136) — Dual Wide Series

with Axial Locking Assembly

Section B

ENGLISH

Size	(Dimensions in inches)										Clearance for "Drop Out" Moving Shafts .250 Apart Drum & Locking Assembly	Element
	D	D ₁	D ₂	D ₇	D ₃₇	D ₃₈	H	M	O	X		
20VC1000	33.59	9.500	23.688	9.500	15.0	10.9	30.000	5.000	½-14 NPT	12.750	.12	.44
24VC1000	33.39	9.312	23.688	9.500	15.7	10.5	34.625	5.000	¾-14 NPT	12.750	.12	.44
28VC1000	34.08	10.000	23.688	10.000	15.4	10.9	38.625	5.000	¾-14 NPT	12.750	.12	.44
32VC1000	36.20	12.000	23.812	12.000	17.1	12.0	44.500	5.000	¾-14 NPT	12.812	.12	.44
38VC1200	41.53	13.000	28.062	13.000	18.2	12.6	50.000	6.000	¾-14 NPT	15.000	.12	.50
42VC1200	45.53	17.000	28.062	17.000	21.6	15.1	54.250	6.000	¾-14 NPT	15.125	.12	.50
46VC1200	45.61	17.000	28.062	17.000	21.7	15.6	61.000	6.000	¾-14 NPT	15.250	.12	.50
52VC1200	46.61	17.000	29.062	17.000	20.9	15.1	67.750	7.000	1"-11 ½ NPT	15.750	.12	.50
51VC1600	57.61	20.000	37.062	20.000	26.4	15.7	67.750	7.000	1"-11 ½ NPT	20.000	.12	.75
60VC1600	62.17	24.000	37.562	24.000	28.5	20.8	77.750	7.000	1¼-11 ½ NPT	20.375	.12	1.00
66VC1600	70.00	Consult Factory	37.000	24.000	28.0	19.2	82.500	Consult Factory	1¼-11 ½ NPT	22.000		.88
75VC1600	74.39	26.750	37.000	27.000	27.6	20.5	93.000	11.630	1¼-11 ⅝ NPT	20.370	.25	1.00
76VC2000	78.39	26.75	45.000	27.000	30.8	21.2	93.500	11.630	1¼-11 ½ NPT	24.370	.25	1.00

SI

Size	(Dimensions in millimeters)										Clearance for "Drop Out" Moving Shafts 6,35 Apart Drum & Locking Assembly	Element
	D	D ₁	D ₂	D ₇	D ₃₇	D ₃₈	H	M	O	X		
20VC1000	853	241	602	241	381	277	762	127	½-14 NPT	324	3,2	11,1
24VC1000	848	236	602	241	399	267	880	127	¾-14 NPT	324	3,2	11,1
28VC1000	866	254	602	254	391	277	981	127	¾-14 NPT	324	3,2	11,1
32VC1000	919	305	605	305	434	305	1130	127	¾-14 NPT	325	3,2	11,1
38VC1200	1055	330	713	330	462	320	1270	152	¾-14 NPT	381	3,2	12,7
42VC1200	1156	432	713	432	549	384	1378	152	¾-14 NPT	384	3,2	12,7
46VC1200	1158	432	713	432	551	396	1549	152	¾-14 NPT	387	3,2	12,7
52VC1200	1184	432	738	432	531	384	1721	178	1"-11 ½ NPT	400	3,2	12,7
51VC1600	1463	508	941	508	671	399	1721	178	1"-11 ½ NPT	508	3,2	19,0
60VC1600	1579	610	954	610	724	528	1975	178	1¼-11 ½ NPT	518	3,2	25,4
66VC1600	1778	Consult Factory	940	610	711	488	2096	Consult Factory	1¼-11 ½ NPT	559	6,3	22,2
76VC1600	1889	680	940	686	701	521	2362	296	1¼-11 ⅝ NPT	517	6,3	25,4
76VC2000	1991	680	1143	686	782	539	2362	295	1¼-11 ½ NPT	619	6,3	25,4

Airflex®VC Mounting Components

Form VC-521 Spiders — Single Narrow Sizes

— Dimensional and Technical Data

Section B

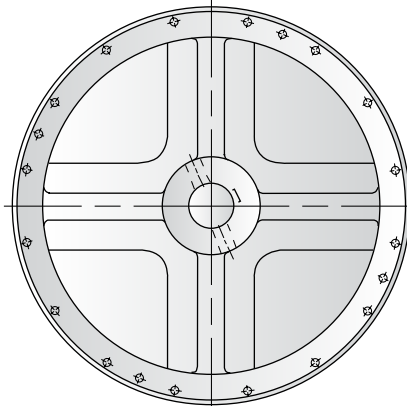
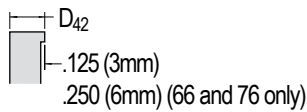
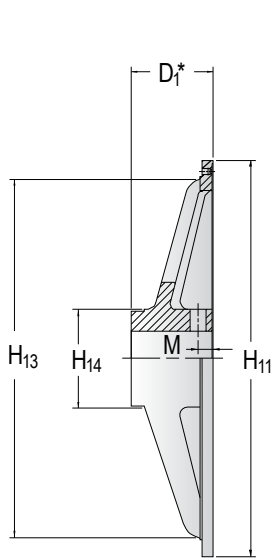

Sizes 14 thru 24

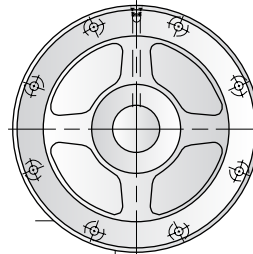

Size 11.5

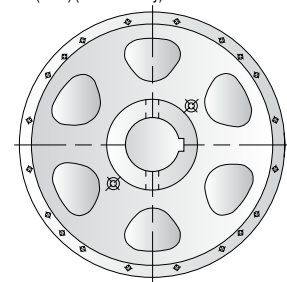

Sizes 28 thru 42

Spider Web Configurations

* D_1 is measured between the machined surfaces of the hub and spidered rim.

Spider shown is for sizes 14 thru 24

ENGLISH

Size	Part Number	Weight (lb)	Wk ² (lb·ft ²)	(Dimensions in inches)				
				D_1	D_{42}	H_{11}	H_{13}	H_{14}
11.5VC500	408376	70	19	4.34	0.59	20.00	N/A	6.00
14VC500	411170	102	35	5.50	1.06	24.00	21.25	8.00
16VC600	408277	139	50	5.50	1.06	26.00	23.25	8.00
20VC600	408279	224	122	6.00	1.06	30.00	27.00	8.50
24VC650	408281	260	174	6.50	1.06	34.63	31.00	9.00
28VC650	505480	514	534	8.00	1.13	38.63	35.25	11.50
33VC650	505285	716	811	9.00	1.13	45.25	41.00	13.50
37VC650	505275	940	1404	10.00	1.25	49.25	45.50	13.50
42VC650	502369	1284	2106	11.00	1.31	54.25	50.48	16.50

SI

Size	Part Number	Mass (kg)	J (kg·m ²)	(Dimensions in millimeters)				
				D_1	D_{42}	H_{11}	H_{13}	H_{14}
11.5VC500	408376	32	0,80	110	15	508	N/A	152
14VC500	411170	46	1,47	140	27	610	540	203
16VC600	408277	63	2,10	140	27	660	591	203
20VC600	408279	101	5,12	152	27	762	686	216
24VC650	408281	118	7,31	165	27	880	787	229
28VC650	505480	233	22,43	203	29	981	895	292
33VC650	505285	324	34,06	229	29	1149	1041	343
37VC650	505275	426	58,97	254	32	1251	1156	343
42VC650	502369	582	88,45	279	33	1378	1282	419

Notes:

Refer to VC Spider Piping and Configuration catalog page for other sizes.

For size 11.5, part number for two air passages.
Part number for single air passage - 408375.

Table data based upon minimum bore.

Airflex®VC Mounting Components

Form VC-522 Spiders — Single Narrow Sizes

— Dimensional and Technical Data

Section B

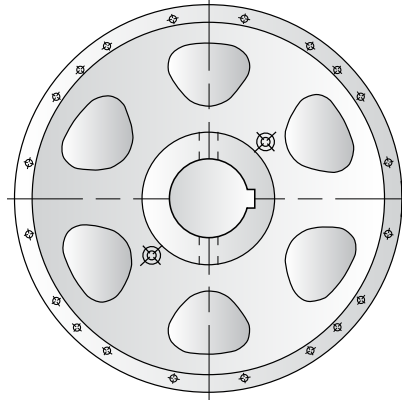
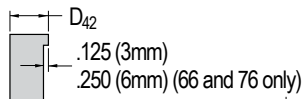
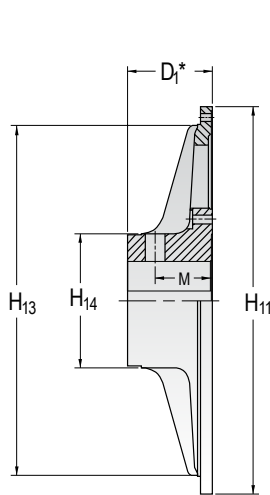

Sizes 16 thru 42

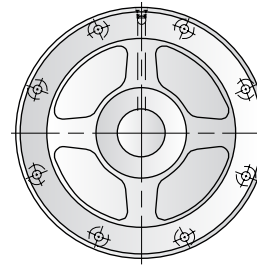

Size 11.5

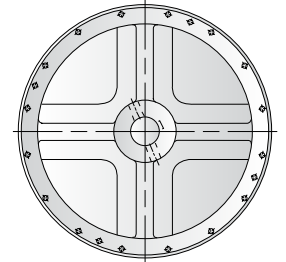

Size 14

Spider Web Configurations

*D₁ is measured between the machined surfaces of the hub and spidered rim.

Spider shown is for sizes 20 thru 24 1

ENGLISH

Size	Part Number	Weight (lb)	Wk ² (lb-ft ²)	(Dimensions in inches)				
				D ₁	D ₄₂	H ₁₁	H ₁₃	H ₁₄
11.5VC500	410856	71	19	4.84	0.62	20.00	N/A	7.50
14VC500	411170	102	35	5.50	1.06	24.00	21.25	8.00
16VC600	505283	236	111	5.50	1.50	26.00	23.00	10.00
20VC600	509698	295	167	7.00	1.13	30.00	27.00	10.00
24VC850	509699	408	285	7.75	1.13	34.63	31.50	12.00
28VC650	509700	554	474	8.00	1.13	38.63	35.25	14.00
33VC650	509701	802	965	9.00	1.13	45.25	41.00	15.00
37VC650	509702	981	1356	10.00	1.25	49.25	45.50	15.50
42VC650	509703	1116	1868	11.00	1.31	54.25	50.50	16.50

SI

Size	Part Number	Mass (kg)	J (kg-m ²)	(Dimensions in millimeters)				
				D ₁	D ₄₂	H ₁₁	H ₁₃	H ₁₄
11,5VC500	410856	32	0,80	122,9	15,8	508,0	N/A	190,5
14VC500	411170	46	1,47	139,7	26,9	609,6	539,7	203,2
16VC600	505283	107	4,66	139,7	38,1	660,4	584,2	254,0
20VC600	509698	134	7,01	177,8	28,7	762,0	685,8	254,0
24VC650	509699	185	11,97	196,9	28,7	879,6	800,1	304,9
28VC650	509700	251	19,91	203,2	28,7	981,2	895,3	355,6
33VC650	509701	363	40,53	228,6	28,7	1149,4	1041,0	381,0
37VC650	509702	444	56,95	254,0	31,8	1251,0	1155,0	388,7
42VC650	509703	506	78,46	279,4	33,3	1378,0	1282,0	419,1

Notes:

1 Refer to VC Spider Piping and Configuration catalog page for other sizes.

Table data based upon minimum bore.

Airflex®VC Mounting Components

Form VC-523 Spiders — Single Wide Sizes

— Dimensional and Technical Data

Section B

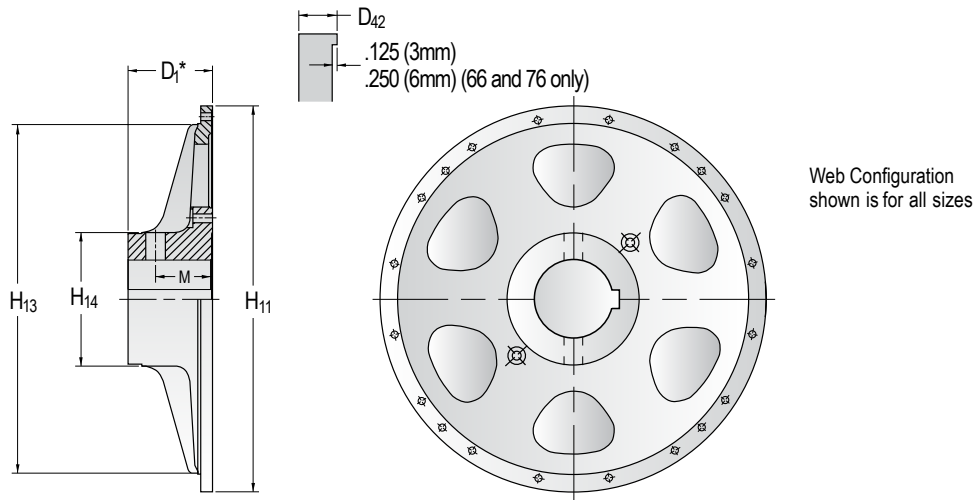

*D₁ is measured between the machined surfaces of the hub and spidered rim.

Spider shown is for sizes 20 thru 241

ENGLISH

Size	Part Number	Weight (lb)	Wk ² (lb-ft ²)	D ₁	(Dimensions in inches)			
					D ₄₂	H ₁₁	H ₁₃	H ₁₄
14VC1000	508545	205	79	5.50	1.13	24.00	21.00	8.00
16VC1000	505283	236	111	5.50	1.50	26.00	23.00	10.00
20VC1000	509698	295	167	7.00	1.13	30.00	27.00	10.00
24VC1000	509699	408	285	7.75	1.13	34.63	31.50	12.00
28VC1000	509700	554	474	8.00	1.13	38.63	35.25	14.00
32VC1000	509706	727	781	9.00	1.13	44.50	41.00	15.00
38VC1200	509707	1002	1502	10.00	1.25	50.00	45.50	15.50
42VC1200	509703	1116	1868	11.00	1.31	54.25	50.50	16.50
46VC1200	509708	1504	2968	11.00	1.50	61.00	56.50	17.00
52VC1200	509709	2579	5087	12.50	1.69	67.75	63.25	23.00
51VC1600	509710	2621	6706	15.00	1.69	67.75	63.25	20.00
60VC1600	509711	4096	13346	16.00	1.88	77.75	72.00	26.00

SI

Size	Part Number	Mass (kg)	J (kg-m ²)	D ₁	(Dimensions in millimeters)			
					D ₄₂	H ₁₁	H ₁₃	H ₁₄
14VC1000	508545	93	3,32	140	29	610	533	203
16VC1000	505283	107	4,66	140	38	660	584	254
20VC1000	509698	134	7,01	178	29	762	686	254
24VC1000	509699	185	11,97	197	29	880	800	305
28VC1000	509700	251	19,91	203	29	981	895	356
32VC1000	509706	329	32,80	229	29	1130	1041	381
38VC1200	509707	454	63,08	254	32	1270	1156	394
42VC1200	509703	506	78,46	279	33	1378	1283	419
46VC1200	509708	681	124,7	279	38	1549	1435	432
52VC1200	509709	1168	213,7	318	43	1721	1607	584
51VC1600	509710	1187	281,7	381	43	1721	1607	508
60VC1600	509711	1855	560,5	406	48	1975	1829	660

Notes:

1 Refer to VC Spider Piping and Configuration catalog page for other sizes.

Table data based upon minimum bore.

Airflex®VC Mounting Components

Form VC-524 Spiders — Dual Wide Sizes

— Dimensional and Technical Data

Section B

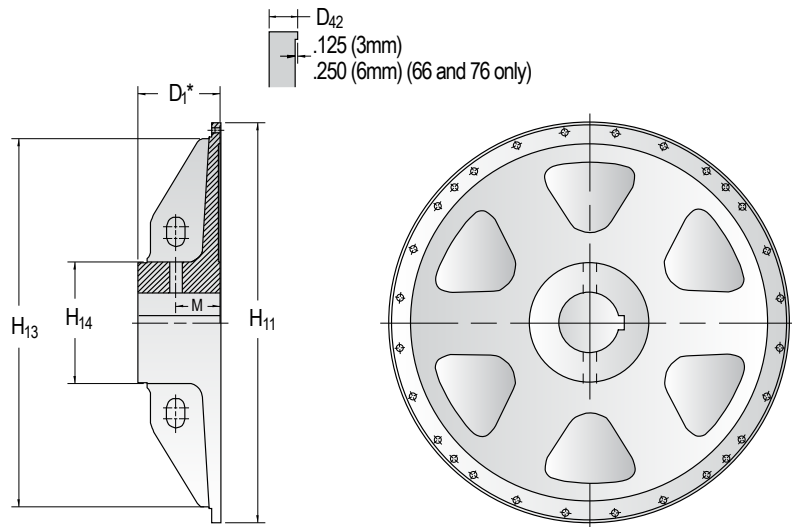

Web Configuration shown is for all sizes

*D₁ is measured between the machined surfaces of the hub and spidered rim.

Spider shown is for sizes 20 thru 24

ENGLISH

Size	Part Number	Weight (lb)	Wk ² (lb-ft ²)	(Dimensions in inches)				
				D ₁	D ₄₂	H ₁₁	H ₁₃	H ₁₄
16VC1000	505284	264	113	8.00	1.50	26.00	23.00	10.00
20VC1000	509693	333	197	9.50	1.13	30.00	27.00	11.00
24VC1000	509694	442	312	9.31	1.13	34.63	31.50	12.50
28VC1000	509695	680	597	10.00	1.13	38.63	35.25	14.00
32VC1000	509696	967	932	12.00	1.13	44.50	41.00	16.75
38VC1200	509646	1350	1625	13.00	1.25	50.00	45.50	18.50
42VC1200	509647	1763	2445	17.00	1.31	54.25	50.50	19.00
46VC1200	509691	1855	3577	17.00	1.44	61.00	56.50	20.00
52VC1200	509648	2854	5277	17.00	1.69	67.75	63.25	23.00
51VC1600	509649	3639	7611	20.00	1.69	67.75	63.25	25.00
60VC1600	509692	5402	14489	24.00	1.88	77.75	72.00	30.00
66VC1600	514261	7385	Consult Factory	25.63	1.88	82.50	76.00	34.50
76VC1600	515152	9245	32860	27.00	1.88	93.00	86.00	38.50
76VC2000	515152	9245	32860	27.00	1.88	93.00	86.00	38.50

SI

Size	Part Number	Mass (kg)	J (kg·m ²)	(Dimensions in millimeters)				
				D ₁	D ₄₂	H ₁₁	H ₁₃	H ₁₄
16VC1000	505284	120	4,75	203	38	660	594	254
20VC1000	509693	151	8,27	241	29	762	686	279
24VC1000	509694	200	13,10	236	29	880	800	318
28VC1000	509695	306	25,07	254	29	981	895	356
32VC1000	509696	438	39,14	305	29	1130	1041	425
38VC1200	509646	612	68,25	330	32	1270	1156	470
42VC1200	509647	799	102,7	432	33	1378	1283	483
46VC1200	509691	840	150,2	432	37	1549	1435	508
52VC1200	509648	1293	221,6	432	43	1721	1607	584
51VC1600	509649	1648	319,7	508	43	1721	1607	635
60VC1600	509692	2447	608,5	610	48	1975	1829	762
66VC1600	514261	3349	CF	651	48	2096	1930	876
76VC1600	515152	4194	1380	686	48	2362	2184	978
76VC2000	515152	4194	1380	686	48	2362	2184	978

Notes:

Refer to VC Spider Piping and Configuration catalog page for other sizes.

Table data based upon minimum bore.

Airflex®VC Mounting Components

Form VC-528— Internal Flange Drums— Narrow Sizes

— Dimensional and Technical Data

Section B

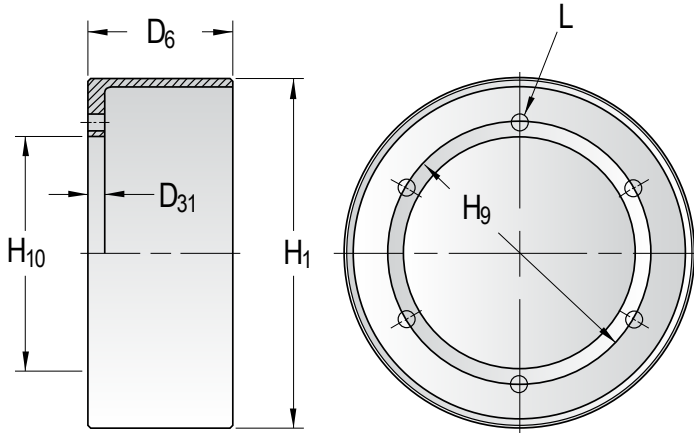

Size	Drum Part Numbers		Dual Elements	
	Single Elements Thru Holes	Tapped Holes	Thru Holes	Tapped Holes
11.5VC500	408290	408291	408306	408307
14VC500	408283	408284	408308	408309
16VC600	408292	408293	408310	408311
20VC600	408294	408295	408312	408313
24VC850	408296	408297	408314	411828
28VC650	409479	408299	408316	408317
33VC650	408300	408301	408318	408319
37VC650	408302	408303	408320	408321
42VC650	408304	408305	408322	408323

ENGLISH

D ₃₁	(Dimensions in inches)				L Holes Tapped	L Holes No.	Single Drum D ₆	Weight (lb)	Wk ² No.	L Holes (In)	D ₆ (lb)	Dual Drum Weight (lb-ft ²)	Size Wk ²	
	H ₁	H ₉	H ₁₀	Thru										
11.5VC500	0.75	11.5	7.250	6.250	0.53	1/2-13	6	6.50	46	9	12	13.13	83	16
14VC500	0.75	14	9.250	8.250	0.53	1/2-13	12	6.50	66	19	12	13.13	139	40
16VC600	0.75	16	9.625	8.250	0.78	3/4-10	8	7.75	94	35	8	15.63	175	66
20VC600	1.00	20	12.000	10.500	0.78	3/4-10	12	7.75	139	78	12	15.63	234	136
24VC850	1.00	24	16.000	14.625	0.78	3/4-10	12	8.25	178	148	16	16.38	293	258
28VC650	1.00	28	20.000	18.500	0.78	3/4-10	16	8.25	231	269	16	16.38	346	472
33VC650	1.00	33	21.500	19.500	0.78	3/4-10	14	8.25	312	486	24	16.44	507	827
37VC650	1.00	37	27.000	25.000	0.78	3/4-10	18	8.25	340	691	32	16.44	553	1172
42VC650	1.13	42	31.000	29.000	0.78	3/4-10	20	8.25	424	1100	36	16.44	662	1809

SI

D ₃₁	(Dimensions in millimeters)				L Holes Tapped	L Holes No.	Single Drum D ₆	Mass (kg)	Mass (kg·m ²)	Wk ² No.	L Holes (mm)	D ₆ (kg)	Dual Drum Mass (kg·m ²)	Size Wk ²
	H ₁	H ₉	H ₁₀	Thru										
11.5VC500	19	292	184,2	158,8	13	1/2-13	6	165	21	0,38	12	333	38	0,67
14VC500	19	356	235,0	209,6	13	1/2-13	12	165	30	0,80	12	333	63	1,68
16VC600	19	406	244,5	209,6	20	3/4-10	8	197	43	1,47	8	397	79	2,77
20VC600	25	509	304,8	266,7	20	3/4-10	12	197	63	3,28	12	397	106	5,80
24VC650	25	610	406,4	371,5	20	3/4-10	12	210	81	6,22	16	416	133	10,84
28VC650	25	711	508,0	469,9	20	3/4-10	16	210	105	11,30	16	416	158	19,82
33VC650	25	838	546,1	495,3	20	3/4-10	14	210	141	20,41	24	418	230	34,73
37VC650	25	940	685,8	635,0	20	3/4-10	18	210	154	29,02	32	418	251	49,22
42VC650	29	1067	787,4	736,6	20	3/4-10	20	210	192	46,20	36	418	300	75,98

Notes:

Tolerance (H₁)
+0.000/-0.010 in
(+0,00/-0,25 mm)

Tolerance (H₁₀)
+0.003/-0.010 in
(+0,08/-0,00 mm)

Tapped L Holes meet
American National Standards
for United Screw Threads.

Airflex®VC Mounting Components

Form VC-528— Internal Flange Drums— Wide Sizes

— Dimensional and Technical Data

Section B

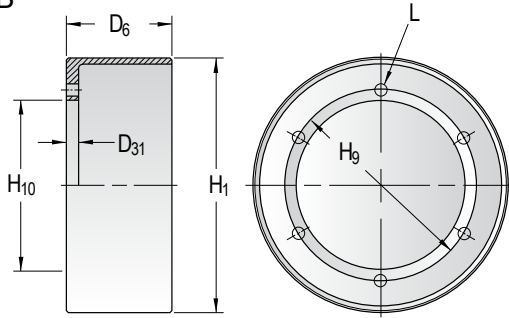

Size	Drum Part Numbers Having		Size	Drum Part Numbers Having	
	Male Register	Female Register		Male Register	Female Register
14VC1000	411111	N/A	42VC1200	409947	409948
16VC1000	409506	410320	46VC1200	409980	409981
20VC1000	410087	410088	52VC1200	409715	409716
24VC1000	409794	409795	51VC1600	409711	409712
28VC1000	409537	409538	60VC1600	411501	411502
32VC1000	410824	410825	66VC1600	413727	413726
38VC1200	409474	409475	76VC1600	515149	515150
			76VC2000	515382	515383

ENGLISH

Size	(Dimensions in inches)				L Holes No	L Holes Size	D ₃₁ (in)	Male Register Drums			Female Register Drums	
	D ₆	H ₁	H ₉	H ₁₀				Weight (lb)	Wk ² (lb-ft ²)	D ₃₁ (in)	Weight (lb)	Wk ² (lb-ft ²)
14VC1000	11.50	14	9.250	8.250	12	½-13 NC	0.88	122	35	N/A	N/A	N/A
16VC1000	11.50	16	11.500	10.000	See Notes	0.78	1.00	130	38	0.88	94	37
20VC1000	11.50	20	15.000	13.500	See Notes	0.78	1.00	169	112	0.88	164	109
24VC1000	11.50	24	16.000	14.625	See Notes	0.78	1.00	225	192	0.88	215	186
28VC1000	11.50	28	20.000	18.500	See Notes	0.78	1.00	295	350	0.88	282	338
32VC1000	11.50	32	21.000	19.000	See Notes	0.78	1.00	371	559	0.88	352	537
38VC1200	13.63	38	27.000	25.000	See Notes	0.78	1.00	552	1214	0.88	530	1173
42VC1200	13.63	42	31.000	29.000	See Notes	0.78	1.13	582	1567	1.00	550	1510
46VC1200	13.63	46	34.500	32.500	See Notes	1.03	1.25	729	2357	1.13	700	2276
52VC1200	13.88	52	40.000	38.000	See Notes	1.06	1.25	852	3552	1.13	820	3425
51VC1600	18.13	51	40.000	38.000	See Notes	1.06	1.25	890	4145	1.13	860	4035
60VC1600	17.75	60	46.000	42.000	24	1.56	1.75	1640	8810	1.63	1590	8575
66VC1600	18.25	66	48.000	44.000	See Notes	1.56	1.75	1905	15070	1.50	1770	14340
76VC1600	18.25	76	58.000	54.000	See Notes	1.56	1.75	2230	19861	1.50	2060	18542
76VC2000	22.25	76	58.000	54.000	See Notes	1.56	1.75	2780	25000	1.50	2640	23900

SI

Size	(Dimensions in millimeters)				L Holes No	L Holes Size	D ₃₁ (mm)	Male Register Drums			Female Register Drums	
	D ₆	H ₁	H ₉	H ₁₀				Weight (kg)	Wk ² (kg·m ²)	D ₃₁ (mm)	Weight (kg)	Wk ² (kg·m ²)
14VC1000	292	356	235,0	209,6	12	½-13 NC	22	55	1,47	N/A	N/A	N/A
16VC1000	292	406	292,1	254,0	See Notes	20	25	59	1,60	22	43	1,55
20VC1000	292	508	381,0	342,9	See Notes	20	25	77	4,70	22	74	4,58
24VC1000	292	610	406,4	371,5	See Notes	20	25	102	8,06	22	97	7,81
28VC1000	292	711	508,0	469,9	See Notes	20	25	134	14,70	22	128	14,20
32VC1000	292	813	533,4	482,6	See Notes	20	25	168	23,48	22	159	22,55
38VC1200	346	965	685,8	635,0	See Notes	20	25	250	50,99	22	240	49,27
42VC1200	346	1067	787,4	736,6	See Notes	20	29	264	65,81	25	249	63,42
46VC1200	346	1168	876,3	825,5	See Notes	26	32	330	98,99	29	317	95,59
52VC1200	353	1321	1016,0	965,2	See Notes	27	32	386	149,2	29	371	143,9
51VC1600	461	1295	1016,0	965,2	See Notes	27	32	403	174,1	29	390	169,5
60VC1600	451	1524	1168,4	1066,8	24	40	44	743	370,0	41	720	360,2
66VC1600	464	1676	1219,2	1117,6	See Notes	40	44	863	632,9	38	802	602,3
76VC1600	464	1930	1473,2	1371,6	See Notes	40	44	1011	837,0	38	934	781,0
76VC2000	565	1930	1473,2	1371,6	See Notes	40	44	1264	1050	38	1200	1005

Notes:

For size 14, drum furnished without male register.

For size 16, male drum has tapped holes. Female has drilled holes. See VC510

Tolerance (H₁) +0.000/-0.010 in

(+0,00/-0,25 mm)

Tolerance (H₁₀) 14 thru 51 +0.003/-0.000 in

(+0,08/-0,00 mm) 60 thru 76 +0.005/-0.000 in (+0,13/-0,00 mm)

For sizes 16-28, 14 Holes based upon a 16 hole pattern. Two holes

180° apart not used.

For sizes 32, 52 & 51, 22 Holes based upon a 24 hole pattern. Two holes 180° apart not used.

For sizes 38 & 46, 30 Holes based upon a 32 hole pattern. Two holes 180° apart not used.

For sizes 42 & 66, 34 Holes based upon a 36 holes pattern. Two holes 180° apart not used.

For sizes 76, 46 Holes based upon a 48 hole pattern. Two holes 180° apart not used.

See Form VC 510 for male and female register drums.

Airflex®VC Mounting Components

Form VC-516— Drum Hubs— Wide Sizes

— Dimensional and Technical Data

Section B

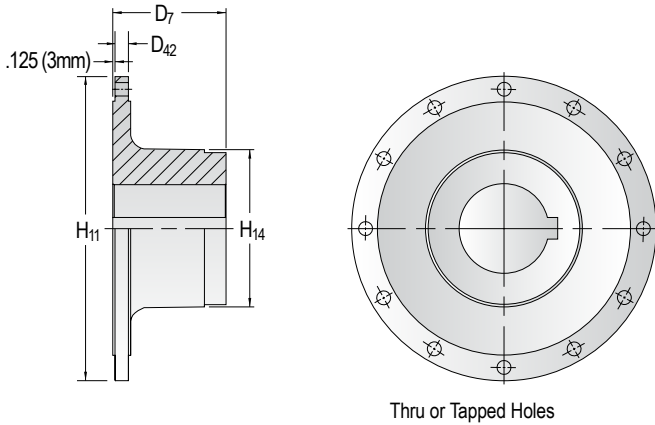

Size	Hub Part Numbers for Single Drums		Dual Drums	
	Thru Holes	Tapped Holes	Thru Holes	Tapped Holes
14VC1000	411113			
16VC1000	407069	407070	410487	407072
20VC1000	407073	407074	407075	407076
24VC1000	405625	405626	407077	407078
28VC1000	405628	405629	408031	407081
32VC1000	405631	405632	407082	407083
38VC1200	405634	405635	406841	407084
42VC1200	405637	405638	410990	407085
46VC1200	405640	405641	408001	407086
52VC1200	407079	407080	407876	407087
51VC1600	408585		408586	
60VC1600	411500		411691	
66VC1600			413725	
76VC1600			515147	
76VC2000			515147	

ENGLISH		For Single Element				For Dual Element				
Size	D ₄₂ (in)	H ₁₁ (in)	Weight (lb)	Wk ² (lb-ft ²)	D ₇ (in)	H ₁₄ (in)	Weight (lb)	Wk ² (lb-ft ²)	D ₇ (in)	H ₁₄ (in)
14VC1000	0.75	10.25	70	5	7.00	7.50				
16VC1000	0.75	13.00	97	9	5.50	9.50	199	19	10.00	9.50
20VC1000	0.75	16.50	150	21	7.00	10.00	203	32	9.50	11.00
24VC1000	1.00	17.50	215	44	7.50	12.00	271	50	9.50	12.75
28VC1000	1.00	21.50	297	82	8.00	13.00	370	99	10.00	14.00
32VC1000	1.00	22.50	407	127	9.50	14.50	574	185	12.00	16.50
38VC1200	1.00	28.50	521	236	10.00	15.50	806	368	13.00	18.50
42VC1200	1.00	32.50	677	378	11.00	16.50	1233	653	17.00	20.00
46VC1200	1.25	36.50	813	577	11.00	17.00	1316	856	17.00	20.00
52VC1200	1.25	42.00	1125	1000	12.50	18.50	1803	1514	17.00	23.00
51VC1600	1.25	42.00	1475	1150	15.00	20.00	2303	1993	20.00	25.00
60VC1600	1.75	49.00	2526	3034	16.00	26.00	4143	4967	24.00	30.00
66VC1600	2.00	51.50	4940	6760	20.00	34.00	6450	7800	24.00	34.00
76VC1600	2.00	61.50	7100	14970	24.00	38.50	7800	15576	27.00	38.50
76VC2000	2.00	61.50	7100	14970	24.00	38.50	7800	15576	27.00	38.50

SI		For Single Element				For Dual Element				
Size	D ₄₂ (mm)	H ₁₁ (mm)	Mass (kg)	Wk ² (kg-m ²)	D ₇ (mm)	H ₁₄ (mm)	Mass (kg)	Wk ² (kg-m ²)	D ₇ (mm)	H ₁₄ (mm)
14VC1000	19	260	32	0,21	178	191				
16VC1000	19	330	44	0,38	140	241	90	0,80	254	241
20VC1000	19	419	68	0,88	178	254	92	1,34	241	279
24VC1000	25	445	97	1,85	191	305	123	2,10	241	324
28VC1000	25	546	135	3,44	203	330	168	4,16	254	356
32VC1000	25	572	184	5,33	241	368	260	7,77	305	419
38VC1200	25	724	236	9,91	254	394	365	15,46	330	470
42VC1200	25	826	307	15,88	279	419	559	27,43	432	508
46VC1200	32	927	368	24,23	279	432	596	35,95	432	508
52VC1200	32	1067	510	42,00	318	470	817	63,59	432	584
51VC1600	32	1067	668	48,30	381	508	1043	83,71	508	635
60VC1600	44	1245	1144	127,4	406	660	1877	208,6	610	762
66VC1600	51	1308	2238	283,9	508	864	2922	327,6	610	864
76VC1600	51	1562	3217	628,7	610	978	3533	654,2	686	978
76VC2000	51	1562	3217	628,7	610	978	3533	654,2	686	978

Notes:

0.25 in (6 mm) for sizes 66 and 76.

Table data based upon minimum bores.

Clutch Applications

Air Tank Group Selection

Section B

Size		Part Number w/o Axial Lock	Part Number w/Axial Lock	Connection	Rotorseal Assembly	AirTank Group Standard	Premium
Single	11.5VC500	104601		1/2	104921	N/A	N/A
Narrow	14VC500	104602		1/2	104921	N/A	N/A
	16VC600	104603		1/2	104921	N/A	N/A
	20VC600	104604		1/2	104907	108702	108602
	24VC650	104605		1/2	104907	108702	108602
	28VC650	104606		1/2	104907	108702	108602
	33VC650	104607		3/4	104908AA	108703	108603
	37VC650	104608		3/4	104908AA	108703	108603
	42VC650	104609		3/4	104908AA	108703	108603
Dual	11.5VC500	104610		1/2	104907	108702	108602
Narrow	14VC500	104611		1/2	104907	108702	108602
	16VC600	104612		1/2	104907	108702	108602
	20VC600	104613	104620	1/2	104907	108702	108602
	24VC650	104614	104621	3/4	104908AA	108703	108603
	28VC650	104615	104622	3/4	104908AA	108703	108603
	33VC650	104616	104623	1	104909AA	108704	108604
	37VC650	104617	104624	1	104909AA	108704	108604
	42VC650	104618	104625	1 1/4	104910AA	108705	108605
Single	16VC1000	104680		1/2	104907	108702	108602
Wide	20VC1000	104681	104700	1/2	104907	108702	108602
	24VC1000	104682	104701	3/4	104908AA	108703	108603
	28VC1000	104683	104702	3/4	104908AA	108703	108603
	32VC1000	104684	104703	1	104909AA	108704	108604
	38VC1200	104685	104704	1 1/4	104910AA	108705	108605
	42VC1200	104686	104705	1 1/4	104910AA	108705	108605
	46VC1200	104687	104706	1 1/2	105519AA	108706	108606
	52VC1200	104688	104707	1 1/2	105519AA	108706	108606
	51VC1600	104689	104708	1 1/2	105519AA	108707	108607
	60VC1600	104690	104709	1 1/2	105519AA	108707	108607
	66VC1600	108111	108112	1 1/2	105519AA	108707	108607
Dual	16VC1000	104720		3/4	104908AA	108703	108603
Wide	20VC1000	104721	104740	1	104909AA	108704	108604
	24VC1000	104722	104741	1	104909AA	108704	108604
	28VC1000	104723	104742	1 1/4	104910AA	108705	108605
	32VC1000	104724	104743	1 1/4	104910AA	108705	108605
	38VC1200	104725	104744	1 1/2	105519AA	108706	108606
	42VC1200	104726	104745	1 1/2	105519AA	108707	108607
	46VC1200	104727	104746	1 1/2	105519AA	108707	108607
	52VC1200	104728	104747	1 1/2	105519AA	108708	108608
	51VC1600	104729	104748	1 1/2	105519AA	108708	108608
	60VC1600	104730	104749	1 1/2	105519AA	108708	108608
	66VC1600	Consult Factory	106972	1 1/2	105519AA	108708	108608
	76VC1600	Consult Factory	108082	2	107815AA	108709	108609
	76VC2000	Consult Factory	108120	2	107815AA	108709	108609

Airflex®CM Construction and Features

Section B

The CM element provides all of the features associated with the type CB element plus greater heat dissipation characteristics. They are used in applications where moderate slippage is encountered which would shorten the operating life of a CB element.

The actuating tube of the CM element is bonded to a steel rim. The rim has male and female registers which allows the elements to be easily assembled into dual and triple arrangements. Ventilated friction shoes are attached to the tube by pins which in turn are held in position by cotter pins. Rubber lugs on the inside diameter of the actuating tube fit into recesses in the friction shoe backing plate providing a positive interface between the shoe and tube.

Element torque capacity is dependent upon the applied pressure and rotating speed. Catalog ratings are given at 75 psi (5,2 bar) and zero speed. Tube construction for the CM elements permits a higher operating pressure than that recommended for CB element. Maximum recommended pressure is 150 psi (10,3 bar). Adjustment for pressure and speed is explained under Selection Procedure.

CM elements are available in 5 sizes which are identified by the drum diameter in inches on which they constrict and the width in inches of its friction lining. For instance, size 26CM475 is designed to constrict on a 26 inch diameter drum and has a friction lining width of 4.75 inches. The smallest CM element will constrict on a 26 inch (660 mm) diameter drum and the largest on a 48 inch (1219 mm). Individual elements can be bolted together to Form dual or triple elements having twice or triple the torque capacity of a single element.

Because the rubber tube is the connecting member between the driving and driven shafts, the CM design offers the following features in addition to the constricting features described earlier in this section.

One moving component

The tube is the only moving component. There are no springs or sliding parts.

Cushioned action

The tube transmits the torque through its sidewalls, cushioning damaging shock loads thereby protecting drive components. The rubber tube construction dampens the effects of torsional vibrations.

Flexible coupling

The tube flexibility is able to compensate for minor shaft misalignment and axial movement.

Ventilated construction



Friction shoe backing plates have air passages through their entire length resulting in greater thermal capacity.

Where Used:

- Marine Propulsion

Size	Torque Ratings	
	English lb · in @ 75 psi	SI N · m @ 5, 2 bar
26CM475	132000	14920
30CM500	188000	21250
35CM500	264000	29850
40CM550	369500	41770
48CM650	613500	69360

Airflex®CM Elements

Technical Data — Sizes 26 thru 48

Section B

English		lb·in @75psi	rpm	psi/rpm ²	lb · ft ²	lb	in ²	inches		in ³	in
26CM475	146211	132000	1030	40 E-06	280	160	302	0.30	0.21	120	25.81
30CM500	146212	188000	915	48 E-06	430	190	379	0.33	0.18	210	29.81
35CM500	146207	264000	900	900 E-06	900	250	433	0.33	0.18	250	34.81
40CM550	146208	369500	900	68 E-06	1150	310	540	0.33	0.18	320	39.81
48CM650	146209	613500	900	79 E-06	900	400	752	0.33	0.18	430	47.75

Size	Part Number	Mr Torque Rating	Maximum Speed	Cs Centrifugal Loss Constant	Wk ² J	Weight		Friction Area	Friction Lining Thickness		Air Cavity Volume	Minimum Drum Diameter
						Mass			New	Worn		
26CM475	146211	14920	1030	2,8 E-06	11,76	72	2099	8	5	1,97	656	
30CM500	146212	21250	915	3,3 E-06	18,06	86	2634	8	5	3,44	757	
35CM500	146207	29850	900	4,0 E-06	31,92	113	3009	8	5	4,10	884	
40CM550	146208	41770	900	4,7 E-06	48,30	140	3753	8	5	5,25	1011	
48CM650	146209	69360	900	5,5 E-06	84,84	181	5226	8	5	7,05	1213	

SI		N · m @ 5, 2 bar	rpm	bar/rpm ²	kg · m ²	kg	cm ²	millimeters		dm ³	mm
----	--	---------------------	-----	----------------------	---------------------	----	-----------------	-------------	--	-----------------	----

Notes:

- ① Dynamic torque shown, static torque approximately 25% greater.
Torque in each application is dependent upon air pressure and speed.
- ② Tolerance +0.000/-0.006 in (+0,00/-0,15 mm).
- ③ Tolerance +0.005/-0.000 in (+0,13/-0,00 mm).
- ④ American National Pipe Thread
- ⑤ Drum contact with worn shoes.

Airflex®CM Elements

Dimensional Data — Sizes 26 thru 48

Section B

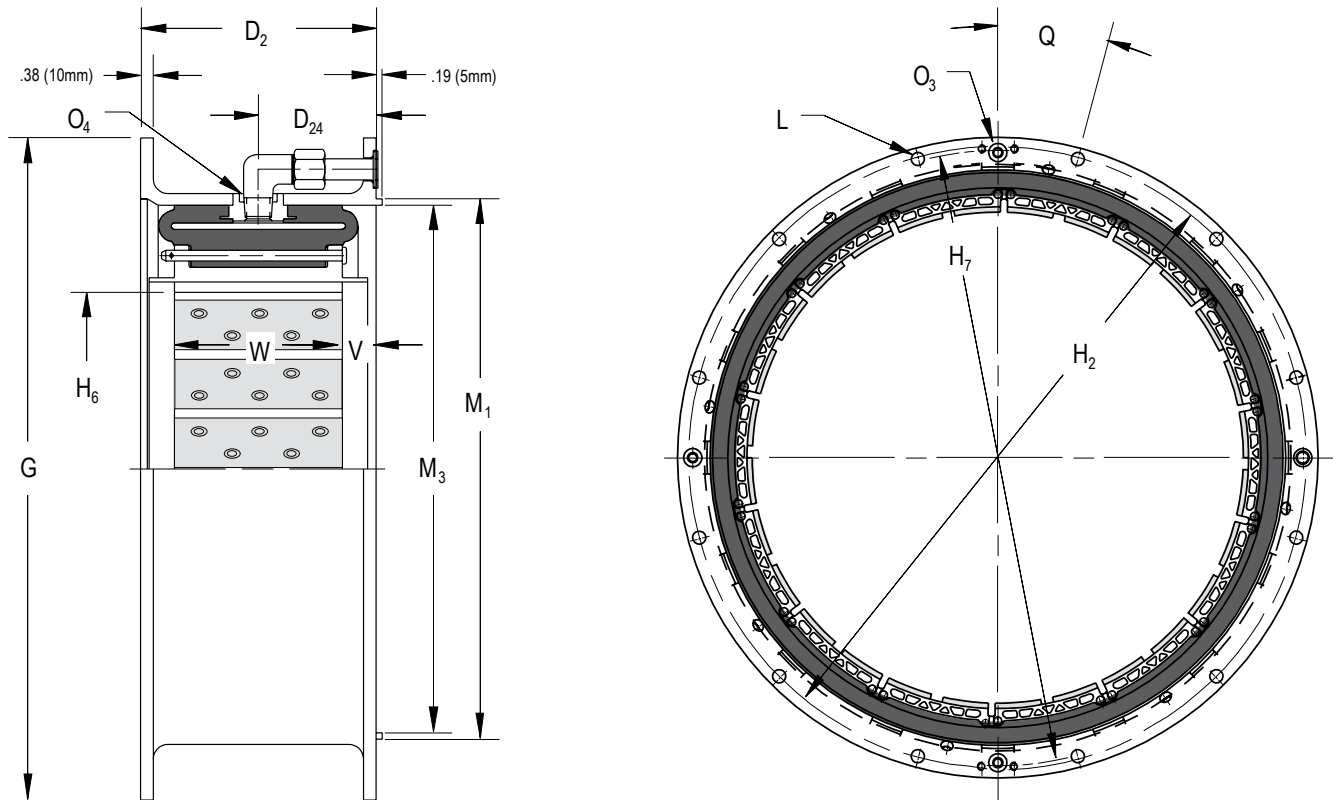

English		lb · in @ 75 psi	Dimensions in inches														
26CM475	146211	132000	6.94	3.38	34.750	33.438	26.19	32.88	12	0.69	31.500	31.125	0.38	3/8-18	15.000	1.00	4.75
30CM500	146212	188000	7.19	3.50	39.375	38.000	30.19	37.50	12	0.81	35.750	35.380	0.50	1/2-14	15.000	1.00	5.00
35CM500	146207	264000	7.69	3.75	45.875	44.375	35.19	43.75	12	0.81	42.000	41.380	0.63	3/4-14	15.000	1.25	5.00
40CM550	146208	369500	8.44	4.13	51.375	49.875	40.19	49.25	12	0.81	47.375	46.755	0.63	3/4-14	15.000	1.38	5.50
48CM650	146209	613500	9.06	4.44	59.500	58.000	48.19	57.25	16	0.81	55.375	54.760	0.63	3/4-14	11.250	1.19	6.50

Size	Mr Part Number	Torque Rating	D ₂	D ₂₄	G	H ₂	H ₆	H ₇	L	M ₁	M ₃	O ₃	O ₄	Q (Deg)	V	W	No. Dia.		
26CM475	146211	14920	176	86	882,7	849,3	665	835	12	18	800,1	790,6	10	3/8-18	15,000	25	121		
30CM500	146212	21250	183	89	1000,1	965,2	767	953	12	21	908,1	898,7	13	1/2-14	15,000	25	127		
35CM500	146207	29850	195	95	1165,2	1127,1	894	1111	12	21	1066,8	1051,1	16	3/4-14	15,000	32	127		
40CM550	146208	41770	214	105	1304,9	1266,8	1021	1251	12	21	1203,3	1187,6	16	3/4-14	15,000	35	140		
48CM650	146209	69360	230	113	1511,3	1473,2	1224	1454	16	21	1406,5	1390,9	16	3/4-14	11,250	30	165		

SI		N · m @ 5,2 bar	Dimensions in millimeters													
----	--	--------------------	---------------------------	--	--	--	--	--	--	--	--	--	--	--	--	--

Airflex®CM Mounting Components

Drums — Dimensional and Technical Data

Section B

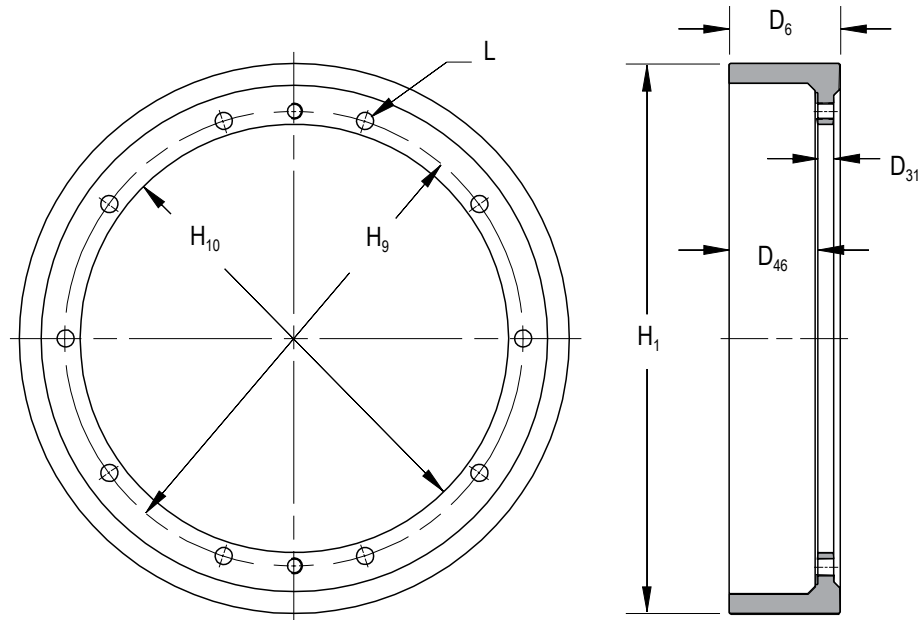

Notes:

- ① Tolerance +0.000/-0.010 in (+0,00/-0,25 mm).
- ② Tolerance +0.003/-0.000 in (+0.08/-0.00 mm).

English		Dimensions in inches										
26CM475	0.75	26	10	0.81	5.25	3.25	16.130	14.750	5.25	4.19	21.630	20.250
30CM500	0.75	30	10	0.88	5.50	3.75	20.130	18.750	5.50	3.88	25.630	24.250
35CM500	1.00	35	10	1.00	6.50	4.25	23.505	21.875	6.69	4.25	30.005	28.375
40CM550	1.25	40	10	1.06	6.50	4.00	26.255	24.375	6.50	3.50	33.755	31.875
48CM650	1.25	48	12	1.06	7.00	3.06	37.760	35.875	7.00	4.50	42.010	40.000
Size	D ₃₁	H ₁	L	Forward Drive Drum				Reverse Drive Drum				
			No.	Dia.	D ₆	D ₄₆	H ₉ ①	H ₁₀ ②	D ₆	D ₄₆	H ₉ ①	H ₁₀ ②
26CM475	19	660	10	21	133	83	409,7	374,7	133	106	549,4	514,4
30CM500	19	762	10	22	140	95	511,3	476,3	140	99	651,0	616,0
35CM500	25	889	10	25	165	108	597,0	555,6	170	108	762,1	720,7
40CM550	32	1016	10	27	165	102	666,9	619,1	165	89	857,4	809,6
48CM650	32	1219	12	27	178	78	959,1	911,2	178	114	1067,1	1016,0
SI	Dimensions in millimeters											

Forward Drive Drum

Size	Part Number	English		SI	
		Weight lb	Wk ² lb · ft ²	Mass kg	J kg · m ²
26CM475	512239	190	170	86	7,14
30CM500	512349	210	280	95	11,76
35CM500	512241	310	570	140	23,94
40CM550	512243	460	990	208	41,58
48CM650	512245	590	1970	267	82,74

Reverse Drive Drum

Size	Part Number	English		SI	
		Weight lb	Wk ² lb · ft ²	Mass kg	J kg · m ²
26CM475	512240	145	150	66	6,30
30CM500	512350	175	250	79	10,50
35CM500	512242	245	490	111	20,58
40CM550	512244	350	830	159	34,86
48CM650	512246	500	1750	227	73,50

Airflex® Selection Procedure

Element Torque Calculations

Section B

General

Technical Section Y of the catalog contains useful information pertaining to the selection, mounting, alignment and control of clutches and brakes in general. Formulas, symbols and units are also identified. It is recommended that Section Y be reviewed before attempting to size a specific product for an application.

Element Torque Adjustment

The catalog element torque ratings M_r are based upon an effective pressure p_r of 75 psi (5,2 bar). Torque ratings must be adjusted for operating pressure p_o , parasitic loss p_p and operating speed n .

Maximum allowable operating pressure is dependent upon element construction and frequency of engagement. In general, the pressures listed in the following table should not be exceeded.

Maximum Allowable Pressure

Model	English	SI
	psi	bar
CB	110	7,6
CM	150	10,3
VC	125	8,6

The elements have an inherent parasitic pressure p_p required to cause friction shoe contact with its drum which represents the pressure to overcome resiliency of the actuating tube and, for the VC elements, the pressure to overcome friction shoe release springs. Parasitic pressures are given in the following table and must be deducted from the operating pressure.

Parasitic Pressure p_p

Size	English	SI
	psi	bar
3CB	20	1,38
4 and 5CB	15	1,03
6 and 8CB	5	0,34
10 thru 45CB	2	0,14
All CM's	5	0,34
All VC's	4	0,28

A rotating element must have its torque rating adjusted to compensate for the centrifugal force acting on its friction shoes. The method used is to calculate a compensating pressure p_c and deduct its value from the operating pressure.

$$p_c = C_s \cdot n^2$$

where p_c = compensating pressure (psi or bar)

C_s = speed constant obtained from element catalog page (psi/rpm² or bar/rpm²)

n = element rpm

Adjusted element torque M_e is then calculated from:

$$M_e = \frac{p_o - p_p - p_c}{p_r} \cdot M_r$$

The adjusted element torque M_e must then be equal to or greater than the required clutch torque M_c or brake torque M_b .

Examples 1, 2 & 3 at the end of this section illustrates the use of the above Formulas.

Airflex® Selection Procedure

Thermal Capacities

Section B

Continuous Thermal Capacity

Constricting elements are generally not recommended for continuous slip applications. This type of application is best handled by the expanding, caliper and water-cooled product lines (see Sections C, H and I).

Non-Cyclic Thermal Capacity

Non-cyclic thermal capacity is determined by the element's friction area, drum mass, heat capacity and thermal conductivity. The properties of our standard gray iron drums result in the limits indicated in the Non-Cyclic Energy Capacity Graph. An explanation on the use of this graph follows.

The thermal energy calculated for the load is adjusted to include the energy associated with accelerating or decelerating the components of the tentative clutch and/or brake selection. The adjusted thermal energy W_t is divided by the element's friction area A . Next, the average power loading P_{ave} is calculated from:

$$P_{ave} = \frac{P_t}{A}$$

The point $(W_t/A, P_{ave})$ is plotted on the graph. If the point falls below the appropriate product limit line, the selection will handle the thermal load. If it does not, an element having a greater friction area is required.

Example 4 at the end of this section illustrates the use of the graph.

Non-Cyclic Thermal Capacities
(Gray iron drums)

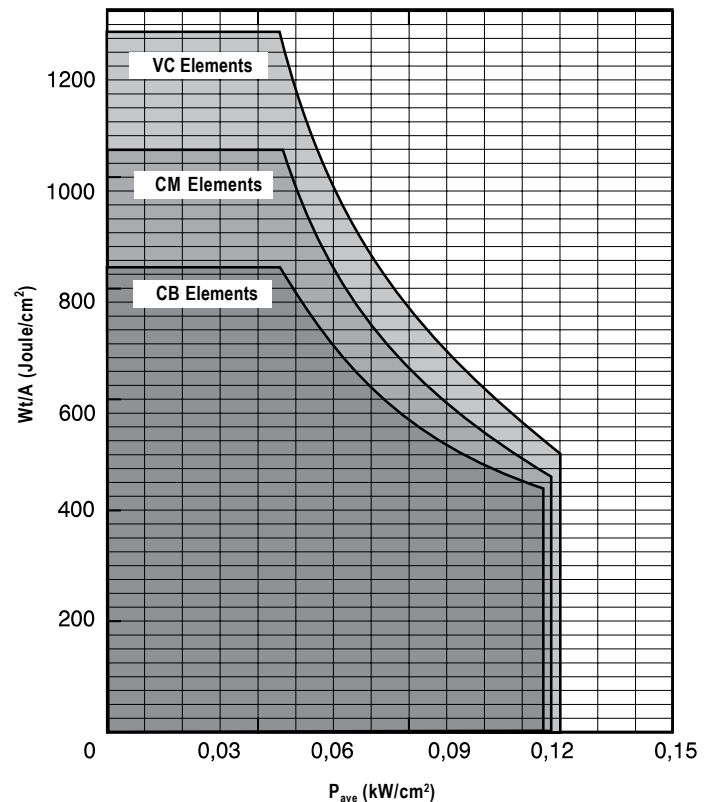
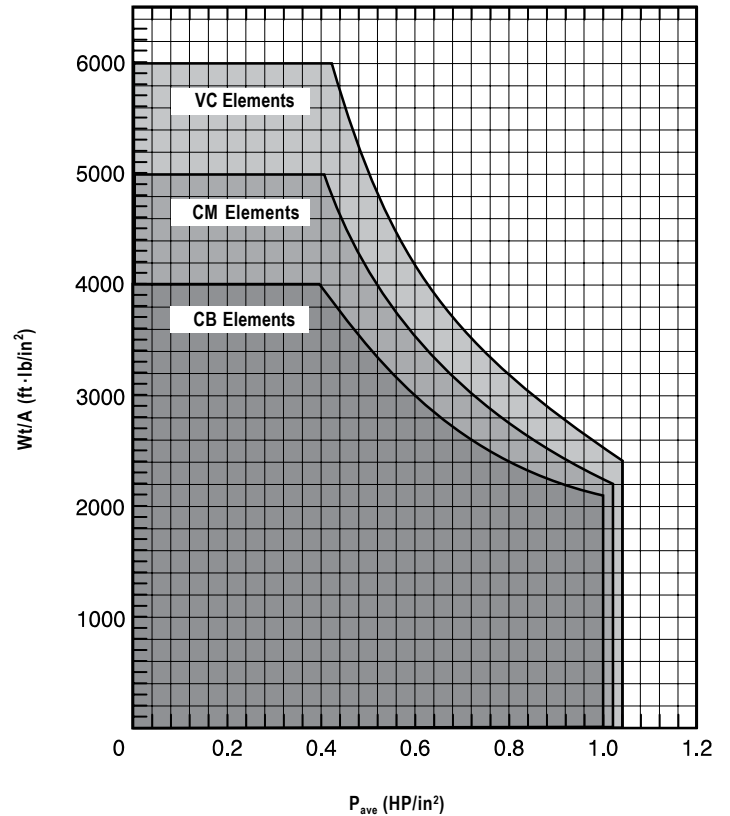

Airflex® Selection Procedure

Thermal Capacities

Section B

Cyclic Thermal Capacity

The cyclic thermal capacity of a clutch or brake is dependent upon the design and arrangement of the mounting components and their operating speed. Components with the smaller inertias should be mounted on the shaft which is started and/or stopped with each cycle. Protective guards should be designed to assure adequate air circulation.

Cyclic thermal capacities P_c for CB and VC elements are determined from the following graphs. CM elements are not recommended for cyclic duty because the thermal requirement can be handled more efficiently by a smaller diameter VC element. The capacities are for applications having the drum and hub on the driven side of the installation. Elements should have the maximum number of tube inlets. The capacities P_g obtained from these graphs must be multiplied by the appropriate arrangement factor K_t given in the table.

$$P_c = P_g \cdot K_t$$

The element's cyclic thermal capacity P_c must be greater than or equal to the thermal power requirement.

Example 5 at the end of this section illustrates the use of these graphs.

Arrangement Factors K_t

Arrangement	Single Element	Dual Element
Spider	1.0	1.6
Ventilated Adapter	1.67	2.67
Brake	0.5	0.8

Airflex® Selection Procedure

Section B

Component Peripheral Velocities

Component velocities must be below the values given in the table. In some applications, components may be required to freewheel at speeds much faster than their engaged running speeds. This must be taken into consideration when calculating their velocities. Velocities are calculated by:

$$v \text{ (fpm)} = 0.262 nD$$

$$v \text{ (mps)} = 5,236E.05 nD$$

where D = outside diameter of component (in or mm).

Maximum Peripheral Speed

Component	fpm	mps
Spider	8500	43
Drum	8500	43
Hub	8500	43
Ventilated Adapter	6500	33

Selection Method

Two selection procedures are discussed in section Y. The analytical method results in an optimum selection for the drive whereas the service factor method may result in an under or over sized unit. Whenever possible, the analytical method should be used. The procedure to follow for constricting products is discussed below followed by the service factor procedure procedures.

Procedures for specialized machines or equipment used in a particular industries are given in Section X.

Analytical Method

The steps to follow are:

1. Determine the torque requirement.
2. Determine the thermal requirement.
3. Determine the mounting arrangement, mounting space and shaft diameters.
4. Make a tentative selection from saps 1,2 and 3.
5. Adjust the torque rating of the tentative selection to reflect the operating pressure and speed and determine if it still-meets the requirement.
6. Adjust the thermal requirement to include the energy of the clutch and/or brake components which are accelerated or decelerated and determine if it is within the tentative selection's capacity.
7. Check drum and spider peripheral velocities to determine if they are within the components operational limits given in the table.

Refer to catalog sections X and Y to determine the requirements for Step 1 and 2. Step 3 requires some measurements be made to ensure the arrangement does not interfere with the surroundings. If the tentative selection does not meet the requirements

of Step 5, 6 and 7, a larger element or a smaller dual element should be considered. Steps 4 thru 7 should then be repeated for the new selection. If the new selection still does not meet the requirements of steps 5 and 6, a different product line should be considered. If this selection does not meet the requirements of Step 7, it may be possible to fabricate the components of other materials which can withstand the stresses associated with fast operating speeds.

Service Factor Selection Method

Obtain the service factor SF from the Service Factor Table given in Section Y. If the machine or equipment is not listed use the service factor for a machine which performs a similar function. Multiply the prime mover power P, by the service factor to obtain the design power PD'

$P_n = P \cdot SF$

For clutch applications use a rating at 75 psi (5.2 bar), use the design power graphs to select an element which has the design power capacity at the element's operating speed. These graphs are for single clutch elements. Dual clutch elements have twice the capacity shown. For clutch applications operating at other pressures, or for stationary brake elements the service factor is applied to the prime mover's torque M, referred to the clutch or brake shaft. The required clutch torque M_c or the required brake torque M_b is used to make a tentative element selection. The element torque M_e is adjusted for operating speed and pressure as explained earlier. The adjusted element torque M_e must be equal to or greater than M_c or M_b.

Products we offer:

- Cartridge valves
- DCV directional control valves
- Electric converters
- Electric machines
- Electric motors
- Gear motors
- Gear pumps
- Hydraulic integrated circuits (HICs)
- Hydrostatic motors
- Hydrostatic pumps
- Orbital motors
- PLUS+1® controllers
- PLUS+1® displays
- PLUS+1® joysticks and pedals
- PLUS+1® operator interfaces
- PLUS+1® sensors
- PLUS+1® software
- PLUS+1® software services, support and training
- Position controls and sensors
- PVG proportional valves
- Steering components and systems
- Telematics

Danfoss Power Solutions is a global manufacturer and supplier of high-quality hydraulic and electric components. We specialize in providing state-of-the-art technology and solutions that excel in the harsh operating conditions of the mobile off-highway market as well as the marine sector. Building on our extensive applications expertise, we work closely with you to ensure exceptional performance for a broad range of applications. We help you and other customers around the world speed up system development, reduce costs and bring vehicles and vessels to market faster.

Danfoss Power Solutions – your strongest partner in mobile hydraulics and mobile electrification.

Go to www.danfoss.com for further product information.

We offer you expert worldwide support for ensuring the best possible solutions for outstanding performance. And with an extensive network of Global Service Partners, we also provide you with comprehensive global service for all of our components.

Local address:

Hydro-Gear

www.hydro-gear.com

Daikin-Sauer-Danfoss

www.daikin-sauer-danfoss.com

Danfoss Power Solutions (US) Company
2800 East 13th Street
Ames, IA 50010, USA
Phone: +1 515 239 6000

Danfoss Power Solutions GmbH & Co. OHG
Krokamp 35
D-24539 Neumünster, Germany
Phone: +49 4321 871 0

Danfoss Power Solutions ApS
Nordborgvej 81
DK-6430 Nordborg, Denmark
Phone: +45 7488 2222

Danfoss Power Solutions Trading (Shanghai) Co., Ltd.
Building #22, No. 1000 Jin Hai Rd
Jin Qiao, Pudong New District
Shanghai, China 201206
Phone: +86 21 2080 6201

Danfoss can accept no responsibility for possible errors in catalogues, brochures and other printed material. Danfoss reserves the right to alter its products without notice. This also applies to products already on order provided that such alterations can be made without subsequent changes being necessary in specifications already agreed. All trademarks in this material are property of the respective companies. Danfoss and the Danfoss logotype are trademarks of Danfoss A/S. All rights reserved.