

Technical Information



Warning

Forward this manual to the person responsible for Installation, Operation and Maintenance of the product described herein. Without access to this information, faulty Installation, Operation or Maintenance may result in personal injury or equipment damage.

Installation, Operation and Maintenance of Airflex By Danfoss DBB Brake Assembly with Corrosion Protection



Caution:

Use Only Genuine Danfoss Replacement Parts

Danfoss recommends the use of genuine Danfoss replacement parts. The use of non-genuine Danfoss replacement parts could result in substandard product performance, and may void your Danfoss warranty. For optimum performance, contact Danfoss at Danfoss.com

Table of Contents

1.0	INTRODUCTION	2
1.1	Description	2
1.2	How it Works	2
2.0	INSTALLATION	3
2.1	Preparation	3
2.2	Mounting	3
2.3	Air Supply System	4
3.0	OPERATION	5
3.1	Pressure and Speed Limits	5
3.2	Initial Operation	5
3.3	Periodic Maintenance	6
4.0	MAINTENANCE	6
4.1	Wear Limits	6
4.2	Wear Adjustment & Disassembly	8
4.3	Friction Disc Replacement	8
4.4	Cylinder Seal Replacement	10
4.5	Spring Replacement	10
4.6	Bushing Replacement	11
4.7	Assembly Procedures	12
4.8	Corrosion Protection	12
5.0	ORDERING INFORMATION/TECHNICAL ASSISTANCE	13
6.0	PARTS LISTS	14
7.0	REVISIONS	15

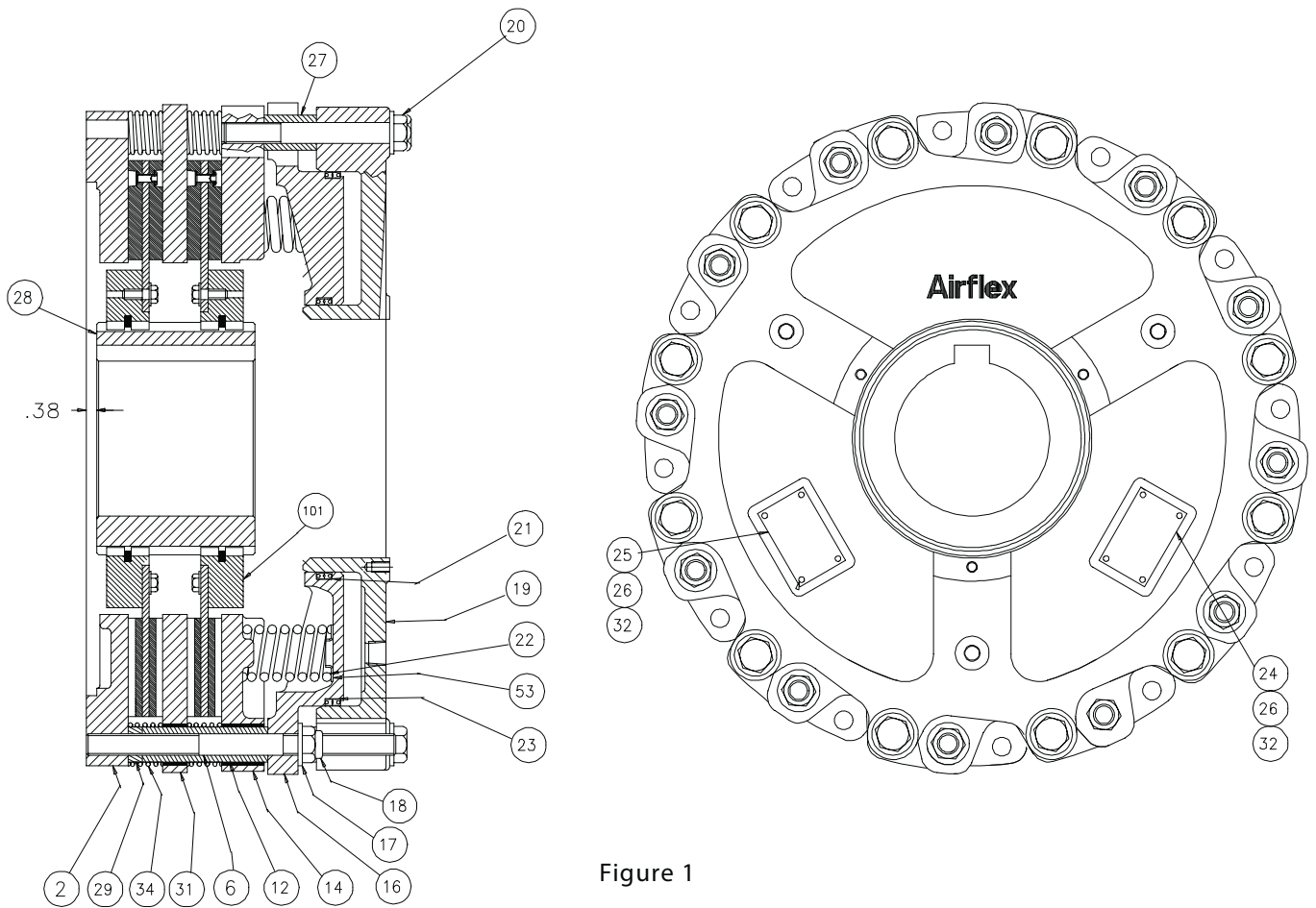



Figure 1

TABLE 1			
Item	Description	Item	Description
2	Mounting Flange	24	Warning Decal
6	Stud	25	Name Plate
12	Clamp Tube	26	Drive Screw
14	Pressure Plate Sub-assembly	27	Spacer Tube
16	Spring Housing	28	Gear
17	Flat Washer	29	Wear Spacer
18	Lock Nut	31	Reaction Plate Sub-assembly
19	Cylinder	32	Decal Plate
20	Hex head Screw	34	Release Spring
21	Polypak seal	36	Hex Head Screw
22	Spring	53	Spring Retainer
23	Polypak Seal	101	Friction disc and ring gear sub-assembly

1.0 INTRODUCTION

Throughout this manual there are a number of **HAZARD WARNINGS** that must be read and adhered to in order to prevent possible personal injury and/or damage to the equipment. Three signal words "**DANGER**", "**WARNING**", and "**CAUTION**" are used to indicate the severity of the hazard, and are preceded by the safety alert symbol .



Danger:

Denotes the most serious hazard, and is used when serious injury or death WILL result from misuse or failure to follow specific instructions.





Warning:

When serious injury or death MAY result from misuse or failure to follow specific instructions.



Caution:

When injury or product/equipment damage may result from misuse or failure to follow specific instructions.

It is the responsibility and the duty of all personnel involved in the installation, operation and maintenance of the equipment on which this device is used to fully understand the  **Caution:**,  **Danger:** and  **Warning:** procedures by which hazards are to be avoided.

1.1 Description

- 1.1.1 The Danfoss Model DBB brakes were designed for heavy duty industrial applications where spring set (power off) braking is required.
- 1.1.2 All Danfoss DBB brakes are supplied with long wearing, NON-AS BE STOS friction material.

- 1.1.3 The spring housing (16) piston and cylinder (19) are Nituff® coated, which is Teflon penetrated hard coat anodizing. The friction disc assembly (101) is made out of steel and is specially nitrided with a quench-polish-quench system. The release springs (34) are made from stainless steel and have flexible polyurethane coating. The exposed cast surfaces are painted with multiple coats of corrosion resistant paint. Bronze bushings are provided in the reaction plate and pressure plates to facilitate axial movement. The clamp tubes (12) are made from aluminum-bronze which provides high resistance to wear and corrosion.

- 1.1.4 The rugged construction ensures long, trouble free service. The corrosion protection provided with these units will help prevent premature failure when using in marine environments. The iron components are painted with a marine, two coat, epoxy coating. All other components are either coated or manufactured with corrosion resistant alloys.

1.2 How it Works

- 1.2.1 Referring to Figure 1, the gear (28) is mounted on the shaft which is to be stopped and the brake assembly is attached to the machine frame or a reaction bracket. As air pressure is applied through the ports in the cylinder (19), the cylinder and pressure plate (13), which are attached to each other with screws (20), flat washers (17) and spacer tubes (27), move away from the mounting flange (1), which is connected to the machine frame or reaction bracket. The pressure plate compresses the springs (22) against the stationary spring housing (16) and the clamp force is removed from the friction disc assembly (7) which rides on the gear. The shaft is then free to rotate. As air pressure is exhausted, the springs force the pressure plate toward the mounting flange, clamping the friction disc assembly between the two members. On dual disc models, an additional friction disc assembly and a reaction plate (30) are clamped between the pressure plate and mounting flange.

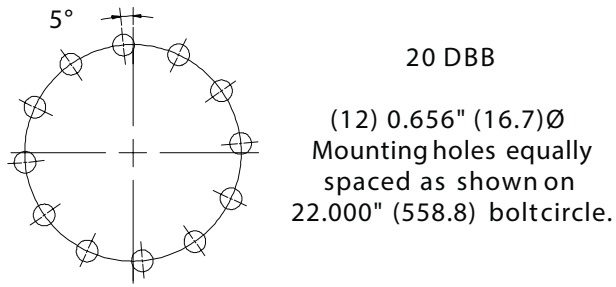

Figure 2

2.0 INSTALLATION

Danger:

Use of commercial grade (Grade 2) fasteners where Grade 8 fasteners are specified may result in failure of the fasteners and a sudden and drastic reduction in brake torque.

Warning:

Only qualified maintenance personnel should install, adjust or repair these units. Faulty workmanship will result in unreasonable exposure to hazardous conditions or personal injury.

Caution:

Read these instructions thoroughly and review until you fully understand the installation sequence before proceeding with the work described in this section. Failure to follow these instructions will result in unreasonable exposure to hazardous conditions or personal injury.

TABLE 2		
Alignment Requirements		
Brake Size	Concentricity of Shaft and Brake in. (mm)	Perpendicularity of Mounting Flange (1) to Shaft in. (mm)
20DBB	0.010 (0.25)	0.010 (0.25)
Perpendicularity referenced to outside diameter of mounting flange from shaft center line (TIR).		

Caution:

Do not paint the clamp tubes (12) or the springs (34) as shown on Figure 1, as this may hinder the engagement or disengagement of the brake.

NOTE: Danfoss recommends guarding the brake application. The guard should cover the face and the entire outer diameter of the unit.

2.1 Preparation

- 2.1.1 Figure 1 shows the relationship between the brake mounting surface and the end of the gear (dimension ".38" on Figure 1). The gear is bored and keyed for a resulting Class FN2S interference fit for inch shafting and ISO System S7h6 for metric shafting.
- 2.1.2 Figure 2 shows the mounting dimensions for the brake to the machine frame or reaction bracket.

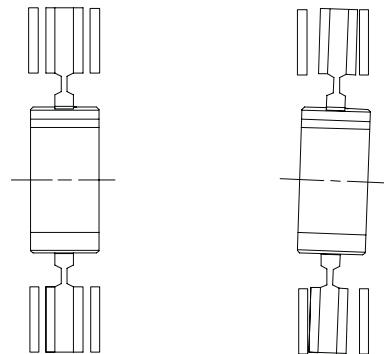

Correct Track

Incorrect Track

Figure 3

2.1.3 Alignment

2.1.3.1 For proper operation and service life, the brake reaction member must be aligned to the shaft within the limits shown on Table 2.



Caution:

Proper alignment is necessary to assure the friction discs track properly. Improper alignment will result in excessive wear to the friction material and its mating surfaces, gear and ring gear. See Figure 3.

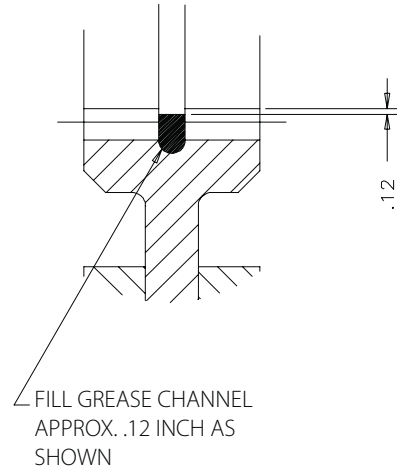

Figure 4

2.2 Mounting

NOTE: Prior to installing the brake, apply 100 psi air pressure releasing the spring tension and slide the gear into the brake assembly aligning the disc sub-assemblies, exhaust the air to clamp them into position and remove the gear.



Warning:

Maximum allowable air pressure is 120 psig (8.2 bar). Application of pressure exceeding maximum allowable may result in damage to the brake.

2.2.1 Ensure the shaft is free of nicks or burrs and the key fits properly in the shaft and gear. Tap the key into the shaft keyway.

2.2.2 Apply a light coat of anti-seizing compound to the shaft and key.

2.2.3 Press the gear onto the shaft, making sure the dimension between the gear and the brake mounting surface (.38") is maintained. See Figure 1 and . Heating the gear uniformly to approximately 250°F (121°C) will expand the bore and ease assembly.

2.2.4 Apply a light coat of MOLUB-ALLOY® 412 ES grease to the gear teeth and pre fill the groove in the friction disc splines as shown on figure 4. Slide the brake assembly onto the gear.

TABLE 3		
Fastener Description and Assembly Torque ft-lb (Nm) [Lubed]		
Fastener		20DBB
Item #18	Description	3/4-10NC-3
	Torque	150 (203)
Item #20	Description	3/4-10NC-2 Gr. 8
	Torque	150 (203)
Item #36	Description	3/8-16NC-2 Gr. 8
	Torque	40 (54)
Mounting Screw	Description	5/8-11NC-2 Gr. 8
	Torque	138 (187)

2.2.5 While supporting the brake, connect an air supply and apply enough pressure to release the brake. Attach the mounting flange (1) to the brake mounting surface using the appropriate fasteners. Torque the fasteners to the specified value. See Table 3.



Danger:

Use only the proper number and grade fasteners shown in Table 4. Use of commercial grade (Grade 2) fasteners where Grade 8 fasteners are specified may result in failure of the fasteners and a sudden and drastic reduction in brake torque.

2.3 Air Supply System



Warning:

Maximum allowable air pressure is 120 psig (8.2 bar). Operation of the DBB at pressures exceeding 120 psig may result in damage to the brake components.



Caution:

Minimum releasing pressure for low pressure brakes is 60 psig (4.1 bar) and for high pressure brakes is 90 psig (6.1 bar). Operation at pressures below minimum will result in brake drag and excessive heat and wear.

- 2.3.1 Since the air control arrangement will vary from one application to the next, a specific description cannot be presented here. Following are some general guidelines for installing the air control components.
 - 2.3.1.1 Use full size piping consistent with the control valve.
 - 2.3.1.2 Keep the number of elbows to a minimum to ensure consistent brake response.
 - 2.3.1.3 Spool type solenoid valves are not recommended. Use poppet type valves and locate as close as possible to the brake.



Warning:

If the DBB brake is being used on a mechanical power press, special valving may be required.

- 2.3.1.4 If the DBB brake is being used on a cyclic application, an air receiver tank should be installed in the air supply line and isolated (check valve) from other air consuming equipment.
- 2.3.1.5 The final connection to the brake inlet ports must be made with flexible hose.

- 2.3.1.6 The DBB brake does not require lubricated air; however the solenoid valve may. Consult the valve manufacturer.
- 2.3.1.7 A pressure switch should be located in the air supply line to the brake and interlocked with the equipment electrical controls.

3.0 OPERATION

3.1 Pressure and Speed Limits

- 3.1.1 Maximum applied pressure is 120 psig (8.2 bar). Minimum releasing pressure for low pressure brakes is 60 PS IG (4.1 bar). Minimum releasing pressure for high pressure brakes is 90 psig (6.1 bar).
- 3.1.2 Maximum disc speed is 1800 RPM.



Warning:

Operation at disc speeds exceeding the maximum allowable, as shown on Table 6, may result in exposure to personal injury or product/equipment damage.

3.2 Initial Operation

- 3.2.1 The non-asbestos friction material used on DBB brakes may not develop rated torque, as a short wear in period is required.



Caution:

The non-asbestos friction material used on Danfoss DBB brakes may not develop rated torque initially, as a short wear in period is required. Machine operation should therefore be monitored closely until the friction material wears in.

- 3.2.2 If the brake engagement appears harsh, a flow control valve may be installed in the brake air supply line. When using a flow control valve, install so free flow is to the brake and restricted flow is away from the brake.



Caution:

Excessive restriction of the brake exhaust air will result in long stopping times and inconsistent stopping position.

- 3.2.3 If the DBB brake is used in combination with a clutch, clutch/brake overlap may occur which will result in excessive heat generation and motor overload. Overlap may be detected by monitoring the drive motor current at the beginning and end of each machine cycle. A current surge at the beginning of the cycle usually indicates clutch overlap which can be corrected by restricting the air flow to the clutch or increasing the air pressure to the brake. A current surge at the end of the machine cycle usually indicates brake overlap which can be corrected by installing and adjusting a flow control valve in the brake air supply line, as indicated in 3.2.2.

3.3 Periodic Inspection

- 3.3.1 As the friction material wears, the brake torque will be reduced somewhat and adjustment of the stopping position controls (flow control or limit switch) will be necessary. See table 4 for the friction material wear limit.
- 3.3.2 Periodically check for air leakage in the area of the cylinder seals (21,23). For replacement, refer to the MAINTENANCE section.
- 3.3.3 Periodically observe the friction disc assembly(s) with the brake released. Dragging friction discs may be caused by wear or contamination at the gear/ring gear contact areas.
- 3.3.4 Pneumatic and electrical control interlocks should be periodically checked for correct settings and operation.
- 3.3.5 Inspect for need for wear adjustment. Refer to Section 4.2.

4.0 MAINTENANCE



Warning:

Prior to performing any maintenance on the DBB brake, make sure the equipment is in, and will remain in, a safe condition.

4.1 Wear Limits

- 4.1.1 Wear limits for the DBB components are shown on Table 4. If any wear limit has been reached or exceeded, that component must be repaired or replaced.

4.2 Wear Adjustment & Disassembly

- 4.2.1 On both single and dual disc units, the friction material must be replaced when worn to the bottom of the groove on the friction lining. See Figure 5. A wear adjustment is required when the friction material is approximately one-half worn. To determine when adjustment is required, measure the gap between the spring housing (16) and the pressure plate (13) with the brake engaged, as shown on Figure 6. When this dimension is .50" (12.7 mm) or greater, AND none of the friction discs are worn to the bottom of the wear groove, adjust per the following procedure.



Warning:

If a wear adjustment is not made, the brake torque may deteriorate to the point where the equipment will not stop properly.



Danger:

The Locknuts (18) must NOT be loosened Unless air pressure is applied to relieve spring pressure.

- 4.2.2 With 120 psi applied to the cylinder (19), loosen and remove the locknuts (18) and washers (17). Exhaust the air pressure. NOTE: The socket size for locknuts (18) is 1 1/16" x 4" deep socket.

TABLE 6

Wear Limits for DBB Brake Components

Item	Description	Wear Limit	Remarks
#7 Friction Disc Assembly	Friction Material	Fully worn at bottom of dust groove. See Figure 6. Friction material must also be replaced when contaminated with oil or grease.	Dual disc brakes have adjustment provision. See 4.2.1.
#1 Mounting Flange	Friction Wear Surface	Maximum wear is .031 in. (.80 mm).	Wear will be in form of circular grooves on iron surface.
#13 Pressure Plate	Friction Wear Surface	Maximum wear is .031 in. (.80 mm).	Wear will be in the form of circular grooves on iron surface.
	Reaction Holes	Maximum wear is .031 in. (.80 mm).	Wear will be in the form of elongation of the holes. Original hole diameters are shown on the table below.
#30 Reaction Plate	Friction Wear Surfaces	Maximum wear (each Side) is .031 in. (.80 mm).	Wear will be in form of circular grooves on iron surface.
	Reaction Holes	Maximum wear is .031 in. (.80 mm).	Wear will be in the form of elongation of the holes. Original hole diameter is 1.343" (34.11mm) .
#12 Clamp Tube	Reaction Area	Maximum wear is .015 in. (.38 mm).	Wear will be in the form of a notch or step on the side of the tube.
#19 Cylinder	Seal Area	Maximum wear is .005 in. (.13 mm).	Wear will be in the form of grooves where the seals contact.
#22 Spring	Spring Free Height	Minimum free height is 4.25" (108mm). Springs must be replaced in complete sets.	Original free height is 4.44/4.56" (113/116mm)
#34 Release Spring	Spring Free Height	Minimum free height is 1.5" (38.1mm)	Original free height is 1.67" (42.4mm).
#28 & #37 Gear and Ring Gear	Gear Backlash	Maximum allowable total backlash is .040 in. (1.0 mm).	Replace ring gear and gear together. If step is worn in gear, gear must be replaced.

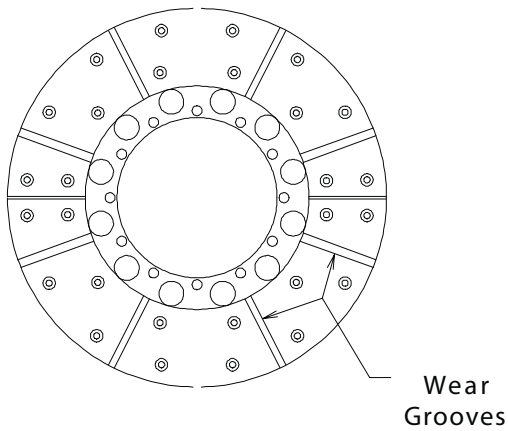

Figure 5

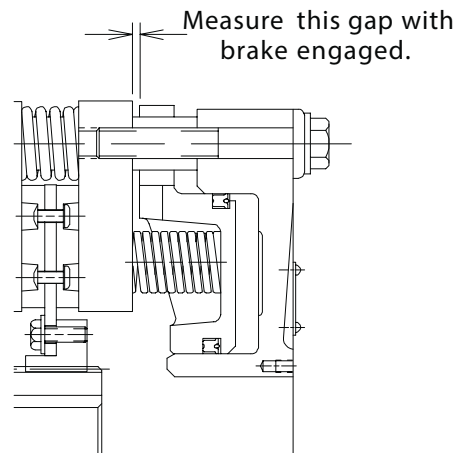

Figure 6

- 4.2.3 Disconnect the air supply lines from the brake.
- 4.2.4 Rig the cylinder assembly. Slide the cylinder (19), spring housing (16) and pressure plate (13) (powerpak) off of the studs as an assembly. Set aside in a clean area making sure not to damage the friction material wear surface on the pressure plate.

Note: If a stud (6) should happen to come loose, remove it completely, clean the threads on the stud and the threads in the mounting flange. Apply Loctite® Primer Grade "T" to the stud threads. After the threads have dried, assemble to the mounting flange using Loctite® #262. The end of the stud must not extend past the mounting surface on the mounting flange.



Caution:

Loctite® #262 must be shaken prior to application.



Caution:

Loctite® #262 may irritate sensitive skin. Refer to the product label for proper safety precautions.

- 4.2.5 Remove the friction disc assemblies, the reaction plates (30) and the release springs (34) and set aside.
- 4.2.6 Slide the clamp tubes (12) and wear spacers (29) off of the studs.
- 4.2.7 Inspect the friction disc for wear. Refer to Table 4 for wear limits. Repair per section 4.3.
- 4.2.8 Inspect the friction wear surfaces on the mounting flange and reaction plate surfaces. If the limits in Table 4 are reached or exceeded replacement is required.
- 4.2.9 Inspect the pressure plate wear surface. If the wear reaches or exceeds then limit in Table 4 replacement is required. Refer to section 4.5 for further dis-assembly procedures.

- 4.2.10 See section 4.4 for cylinder seal replacement.
- 4.2.11 Inspect the clamp tubes, springs (22) and release springs (34) and compare to the limits in Table 4. If any limit is reached, replacement is required.
- 4.2.12 Refer to section 4.5 if spring (22) (34) replacement is required.
- 4.2.13 Re-assemble the brake per section 4.7.

4.3 Friction Material Replacement

- 4.3.1 Disconnect the air supply lines and remove the cylinder/spring housing/pressure plate assembly (powerpac) per 4.2.2 -4.2.4..
- 4.3.2 Remove the friction disc assembly, reaction plate, separator springs and remaining friction disc assembly and transport to a clean work area.
- 4.3.3 Remove the screws and washers attaching the friction disc subassembly to the ring gear and remove the friction disc subassembly.
- 4.3.4 Thoroughly clean the threaded holes in the ring gear and the threads on the screws.
- 4.3.5 Attach a new friction disc subassembly to the ring gear using Loctite® #262 on the screw threads. Torque the screws to the value shown on Table 3.



Warning:

Use only the proper size and grade screws to attach the friction disc sub-assembly to the ring gear. Use of commercial (Grade 2) screws where Grade 8 screws are specified may result in failure of the screws and a sudden loss of brake torque.

- 4.3.6 Friction disc cores may be relined with new friction material per the following instructions. Refer to Table 5 for the appropriate friction disc replacement kit part number.



Caution:

Use only genuine, Danfoss friction material. Use of material not of Danfoss origin may result in unpredictable brake performance and/or excessive wear of the brake components.

- 4.3.6.1 Drill out the old rivets and remove and discard the old friction discs.
- 4.3.6.2 Refer to Figure 7 and carefully examine the counterbored holes in the new friction disc. One set of counterbored holes is **tapered** and designed to accept the **rivet head**, while the other set of counterbored holes is **flat bottomed** and designed to accept the **clinched end of the rivet**.
- 4.3.6.3 Position the friction discs on both sides of the disc core and align the rivet holes. Remember, a tapered counterbored hole on one friction disc will mate with a flat-bottomed counterbored hole on the opposite friction disc.



Caution:

Manual setting of the rivets using a punch very frequently results in splitting of the clinched end of the rivet. When this occurs, the rivet will ultimately fail in service due to fatigue. It is therefore recommended that rivets be set using an automatic rivet setting machine.

- 4.3.6.4 Insert a rivet through any hole and set using a washer on the clinched end of the rivet. Be sure to note the type of counterbored hole to determine the position of the rivet head. See Figures 8 and 9. Figure 8 shows machine-setting and Figure 9 shows setting the rivet manually. When setting manually, use an arbor press and keep the setting tool square to avoid splitting the rivet.

TABLE 5 Friction Disc Repair Kits		
Brake Size	Kit Part Number	Rivet Setting Tool
20DBB	107744D	153x1096
Dual disc brakes require two kits.		



Caution:

The clinched end of the rivet must have a washer in place prior to clinching. Failure to use the washer, or use of excessive force, when clinching the rivet will fracture the friction lining.

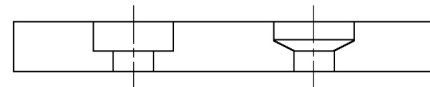

Figure 7

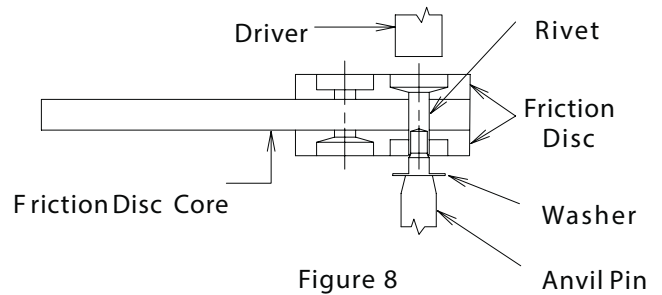

Figure 8

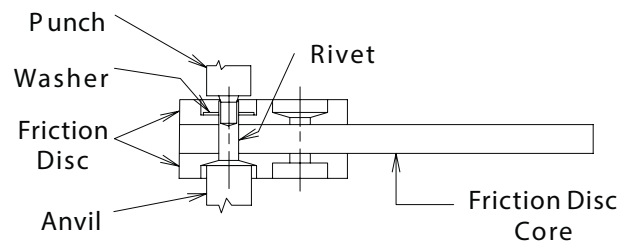

Figure 9

- 4.3.6.5 The remaining rivets may be installed in any reasonable sequence following 4.3.6.4.
- 4.3.7 Attach the ring gear to the friction disc using Loctite[®] #262 and torque screws to 40 ft. lbs.
- 4.3.8 Reassemble per 4.7.

4.4 Cylinder Seal Replacement

- 4.4.1 Disconnect the air supply lines and remove the screws (20), washers (17) and spacer tubes (27) attaching the cylinder (19) to the pressure plate (14).
- 4.4.2 Carefully slide the cylinder off of the spring housing (16).



Caution:

Do not use compressed air to remove the cylinder from the spring housing.

- 4.4.3 Remove the cylinder seals (21,23) from the spring housing and thoroughly clean the seal grooves in the spring housing.
- 4.4.4 Insert new seals into the grooves, noting the orientation of the seals per Figure 10.
- 4.4.5 Carefully examine the seal surfaces in the cylinder. If the surfaces have worn to point as indicated on Table 4, the cylinder must be replaced. Small nicks or scratches must be sanded smooth to prevent air leakage.

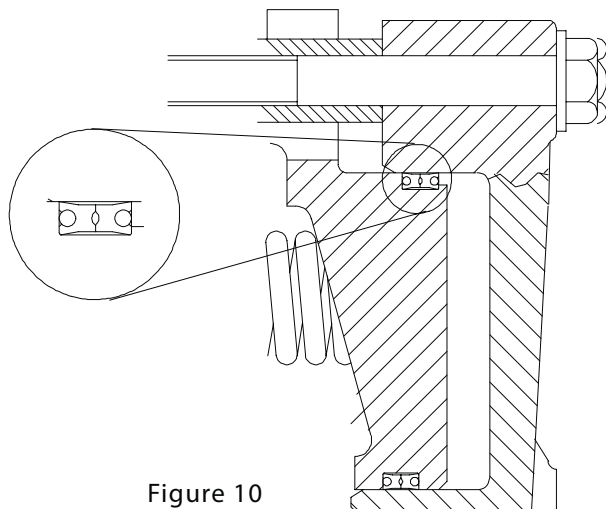

Figure 10

- 4.4.6 Lubricate the seal surfaces in the cylinder with Parker O-Lube[®] and carefully slide the cylinder onto the spring housing. Take special care to avoid damaging the seal lips.
- 4.4.7 Attach the cylinder to the pressure plate with the screws, washers and spacer tubes removed in 4.4.1. Use Loctite[®] Locquic[®] Primer Grade "T" to clean and prepare the screw threads and install with Loctite[®] #262. Using a crosswise pattern, torque the screws to the value shown on Table 3.



Warning:

Loctite[®] Primer "T" contains harmful vapors. Refer to the product label for proper safety precautions.

4.5 Spring Replacement

- 4.5.1 with 100 psi applied to the cylinder (19), loosen and remove the locknuts (18) and washers (17). Exhaust the air pressure.
- 4.5.2 Disconnect the air supply lines from the brake.
- 4.5.3 Loosen the screws (20) gradually until the remaining spring force is relieved. Remove the screws and washers (17).



Warning:

The screws (20) must be loosened gradually to prevent damage to the brake components.

- 4.5.4 Carefully lift the cylinder and spring housing off of the pressure plate, exposing the springs (22).
- 4.5.5 Remove the springs and check the free height. If the free height of any spring is less than the value shown on Table 4, the entire complement of springs must be replaced.
- 4.5.6 Place the springs into the pockets in the pressure plate per Figure 11.
- 4.5.7 Place the spring retainers on top of the springs.

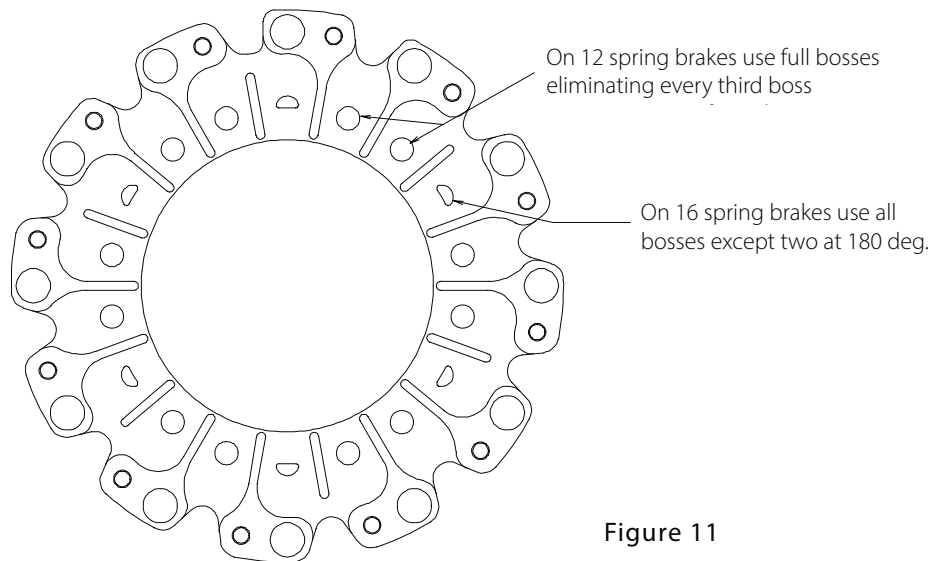

Figure 11

4.5.8 Place a spacer tube (27) in position over each tapped hole in the pressure plate and carefully lower the spring housing/cylinder assembly onto the springs, making sure the springs engage the bosses in the spring housing.

4.5.9 Clean and prepare the threads on the screws (20) with Loctite® Locquic® Primer Grade "T" and install with Loctite® #262, making sure the washers (17) are in place. Using a cross-wise pattern, tighten the screws one turn at a time until the spacer tubes are clamped between the cylinder and the pressure plate. Torque the screws to the value shown on Table 3.

4.5.10 Reassemble per 4.7.

4.6 Bushing Replacement

4.6.1 Remove DBB assembly per section 4.1 and dis-assemble per section 4.2.

4.6.2 Refer to table 4 to determine if the reaction plate bushings (P/N 204114-06) or the pressure plate bushings (P/N 204114-05) require replacement. See figure 12.

4.6.3 Heat up area around bushing to release Loctite® and drive old bushing(s) out.

4.6.4 Clean out bores and remove old Loctite®.

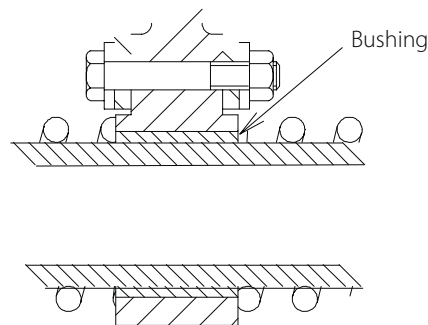

Figure 12

4.6.5 Apply Loctite® #RC601, 635 or 680 to the bushing O.D. and mating hole in the reaction plate using a swab. Apply enough liquid to fill all the space between the parts. Twist the bushing while pushing it down, until it is flush with the casting surface. Inspect to see that the ring of liquid adhesive is visible at the parting line. Allow reaction plate to dry for 15 minutes before moving it.

4.6.6 Re-assemble per 4.7.

4.7 Assembly Procedures

4.7.1 Slide the wear spacers (29) and clamp tubes (12) on of the studs. Reinstall the clamp tubes only, if clearances are larger than .50" (12.7mm) as shown on Figure 7, and friction discs are not fully worn.

NOTE: Install all wear spacers if new friction discs are used.

4.7.2 Place a release spring over every other clamp tube.

4.7.3 Apply a light coat of MOLUB-ALLOY 412 ES grease to the gear teeth and pre fill the groove in the friction disc splines as shown on figure 4.

4.7.4 Slide the friction disc assembly onto the gear, noting the orientation of the heads of the screws attaching the friction disc to the ring gear. The screw heads on the friction discs will face each other.



Warning:

Improper disc/ring gear orientation result in damage to the brake with possible loss of torque.

4.7.5 Slide the reaction plate onto the clamp tubes. Repeat para. 4.7.3 & 4.7.4.

4.7.6 Place a release spring on to every other the clamp tubes and slide the pressure plate/cylinder assembly onto the clamp tubes.

4.7.7 Rig the cylinder/spring housing assembly (Power Pac) onto the studs. Install air line.

4.7.8 With 100 psi air applied to the cylinder (19), lubricate the threads on the ends of the studs with 30 wt. oil or anti-seize compound and install the washers (17), locknuts (18) and wear spacers removed in 4.2.4. The unused wear spacers are "stored" under the locknuts for use only when replacing friction discs. See Figure 14. NOTE: The socket size for locknuts (18) is 1 1/16" x 4" deep.

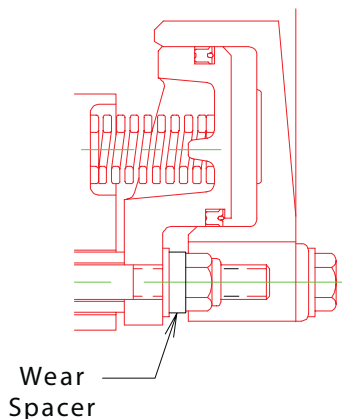

Figure 13

4.7.9 While Supporting the weight of the cylinder/spring housing/pressure plate assembly, tighten the locknuts, ONE TURN AT A TIME and in a crosswise pattern, until the spring housing is seated against the clamp tubes. Torque the locknuts to the appropriate value. See Table 3.



Caution:

The locknuts (18) must be tightened gradually to prevent damage to the brake components.

4.8 Corrosion Protection



Caution:

Do not paint the clamp tubes (12) or the springs (34) as shown on Figure 1, as this may hinder the engagement or disengagement of the tensioner.



Caution:

All previously painted areas must be touched up after maintenance or installation to provide corrosion protection.

- 4.7.1 Clean any contamination, scale, or loose paint from disturbed surfaces.
- 4.7.2 Touch up any disturbed area with an organic zinc primer.
- 4.7.3 Paint areas with two coats of a high solid two part, marine grade epoxy paint as per manufacturers instructions.
- 4.7.4 The following is the original paint specifications and procedures:

GENERAL DESCRIPTION

Dupont[®] Gancin[®] 347-Y-937 (347-Y-A937 liquid and 347-8937 zinc dust) is a two part, one coat epoxy based organic zinc rich primer, applied 3-4 mil dry film thickness with 1.5 hour normal recoat time. NOTE : When mixing one gallon of epoxy and one gallon of zinc, this will yield only one gallon of usable zinc primer.

Dupont[®] 25P (25P base, VF525 activator) high solid epoxy (safety blue color) mastic is a two part, two coat system applied 4-5 mil dry film thickness per coat over zinc primed surfaces with a three hour recoat time. NOTE : When mixing one gallon of paint with one gallon of activator this will yield two gallons of usable cover paint.

READ MANUFACTURES INSTRUCTIONS THOROUGHLY FOR PROPER HANDLING AND SPRAY OF PAINT SYSTEM.

SURFACE PREPARATION

GANCIN[®] 347-Y-937 primer should be applied only to clean, dry metal. Grease, oil and other contaminants should be removed with solvent. Follow instructions in Duponts literature for surface preparations.

MASKING COMPONENTS .

Certain exposed areas of the mounting flange, reaction plate, pressure plate, spring housing, cylinder and assembly must not be painted and need to be masked before painting. The following areas, MUST NOT BE PAINTED, include: All copper wear faces, all bushing bores, all springs, clamp tubes cylinder bore, mounting flange face, spring housing piston and friction discs.

APPLICATION CONDITIONS

Do not apply primer or epoxy if material or ambient temperature is below 35° F (2°C) or above 110° F (43°C). Relative humidity should be below 90%. All necessary precautions must be taken to avoid contamination of the prepared surfaces.

APPLICATION

Handling, mixing, recoat drying times and applications must be in strict accordance with instructions in manufacturers literature.

Within 8 hours after the surface is cleaned and when dry, apply one coat of Dupont[®] Gancin[®] 347-Y-937 organic zinc-rich coating at 3-4 mils dry film thickness.

After the first coat has dried sufficiently for recoat, (normally depending on film thickness, temperature, humidity, and method of application) apply one coat of Dupont[®] 25P epoxy mastic 4-5 mils dry film thickness. After the intermediate coat has dried sufficiently for recoat, (normally depending on film thickness, temperature, humidity and method of application) apply a second coat of Dupont[®] 25P epoxy mastic 4-5 mils dry film thickness to complete three coat paint system for required corrosion resistance.

INSPECTION

Spot check for the following:

Cleanliness and dryness of prepared surfaces.

Wet and dry film thickness after each coat.

Visual inspection for skips, hidings and uniform color, especially after touch-up on the final assembly.

5.0 ORDERING INFORMATION/ TECHNICAL ASSISTANCE

5.1 Equipment Reference

- 5.1.1 In any correspondence regarding Danfoss Equipment, refer to the information on the product nameplate or visit Danfoss.com

6.0 Parts List

Item No.	Description	220 DBB (146300BN)		220 DBB (146300BJ)	
		Quantity	Part Number	Quantity	Part Number
2	Mounting Flange	1	514184	1	514184
6	Stud	12	308139-03	12	308139-03
12	Clamp Tube	12	308207-03	12	308207-03
14	Pressure Plate Sub-assembly	1	416479-02	1	416479-02
16	Spring Housing	1	514016	1	514016
17	Flat Washer	24	000015x1185	24	000015x1185
18	Lock Nut	12	000110x0070	12	000110x0070
19	Cylinder	1	514017	1	514017
20	Hex Head Screw	12	000015x1173	12	000015x1173
21	Polypak Seal	2	000402x0021	2	000402x0021
22	Spring	16	308137	12	308137
23	Polypak Seal	2	000402x0022	2	000402x0022
24	Warning Decal	1	203627	1	203627
25	Name Plate	1	307640	1	307640
26	Drive Screw	8	000153x0644	8	000153x0644
27	Spacer Tube	12	308201-01	12	308201-01
28	Gear	1	308208	1	308208
29	Wear Spacer	12	308208-02	12	308208-02
31	Reaction plate Sub-assembly	1	416479-01	1	416479-01
32	Decal Plate	2	307753	2	307753
34	Release Spring	12	308217	12	308217
53	Spring Retainer	6	415823	6	415823
101	Friction Disc & Ring Gear Sub-assembly	2	416478	2	416478
	Friction Disc	1	514180	1	514180
	Ring Gear	1	514179	1	514179

P/L 146300BN (514208)

P/L 146300BJ (514181)

1 Not included on brake part list.

Products we offer:

- Cartridge valves
- DCV directional control valves
- Electric converters
- Electric machines
- Electric motors
- Gear motors
- Gear pumps
- Hydraulic integrated circuits (HICs)
- Hydrostatic motors
- Hydrostatic pumps
- Orbital motors
- PLUS+1® controllers
- PLUS+1® displays
- PLUS+1® joysticks and pedals
- PLUS+1® operator interfaces
- PLUS+1® sensors
- PLUS+1® software
- PLUS+1® software services, support and training
- Position controls and sensors
- PVG proportional valves
- Steering components and systems
- Telematics

Danfoss Power Solutions is a global manufacturer and supplier of high-quality hydraulic and electric components. We specialize in providing state-of-the-art technology and solutions that excel in the harsh operating conditions of the mobile off-highway market as well as the marine sector. Building on our extensive applications expertise, we work closely with you to ensure exceptional performance for a broad range of applications. We help you and other customers around the world speed up system development, reduce costs and bring vehicles and vessels to market faster.

Danfoss Power Solutions – your strongest partner in mobile hydraulics and mobile electrification.

Go to www.danfoss.com for further product information.

We offer you expert worldwide support for ensuring the best possible solutions for outstanding performance. And with an extensive network of Global Service Partners, we also provide you with comprehensive global service for all of our components.

Local address:

Hydro-Gear

www.hydro-gear.com

Daikin-Sauer-Danfoss

www.daikin-sauer-danfoss.com

**Danfoss
Power Solutions (US) Company**
2800 East 13th Street
Ames, IA 50010, USA
Phone: +1 515 239 6000

**Danfoss
Power Solutions GmbH & Co. OHG**
Krokamp 35
D-24539 Neumünster, Germany
Phone: +49 4321 871 0

**Danfoss
Power Solutions ApS**
Nordborgvej 81
DK-6430 Nordborg, Denmark
Phone: +45 7488 2222

**Danfoss
Power Solutions Trading
(Shanghai) Co., Ltd.**
Building #22, No. 1000 Jin Hai Rd
Jin Qiao, Pudong New District
Shanghai, China 201206
Phone: +86 21 2080 6201