

Clutch/Brake Packages

Section F

CBC Clutch/Brake Combination	203
Dimensional and Technical Data	205
FSPA Packages Description	213
Dimensional and Technical Data	215
AMCB AccuStop Description	223
Dimensional and Technical Data	225
21 DCB Clutch/Brake Description	227
Dimensional and Technical Data	228

CBC Clutch/Brake Combination

Section F

The Airflex® CBC clutch/brake combination consists of an air-actuated disc clutch and a spring-applied disc brake. Its compact design combined with its high thermal capacity and low air consumption makes it ideal for high speed, high cyclic, heavy-duty industrial applications.

The CBC hub is pressed on and keyed to the driven shaft. The clutch disc is fastened to the driving member (a flywheel in most applications). The brake disc is reacted to the machine. Three different means of disc attachment results in five possible mounting arrangements. Operation is simple. When the cylinder is pressurized, the piston clamps the clutch disc to the hub, which transmits torque to the shafts. When the cylinder exhausts, the springs move the piston shaft. Overlapping cannot occur between the clutching and braking. Efficient cooling permits a stable coefficient of friction resulting in reproducible torque control. Minimal torque loss combined with generous friction lining area results in low operating and maintenance costs.

CBC units are available in 6 standard sizes with clutch torque to 1,140,000 lb-in (129,000 N·m) and brake torque to 529,000 lb-in (60,000 N·m).

Where used:

- Automatic Punching Machines
- Press Brakes
- Printing Machines
- Shears
- Stamping and Forming Presses
- Woodworking Machines

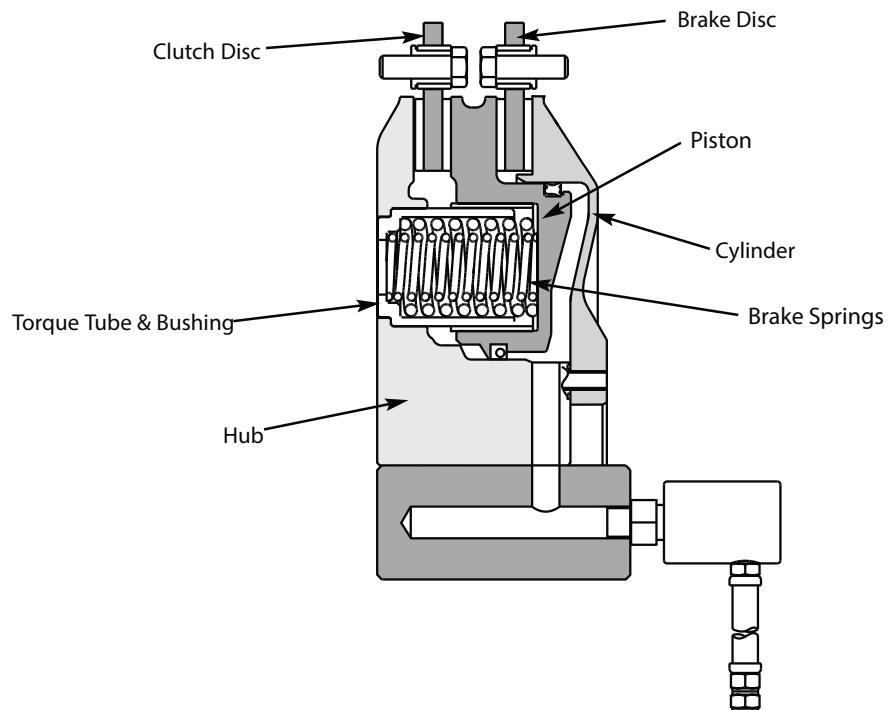

CBC Clutch/Brake Combination Component Parts

Section F

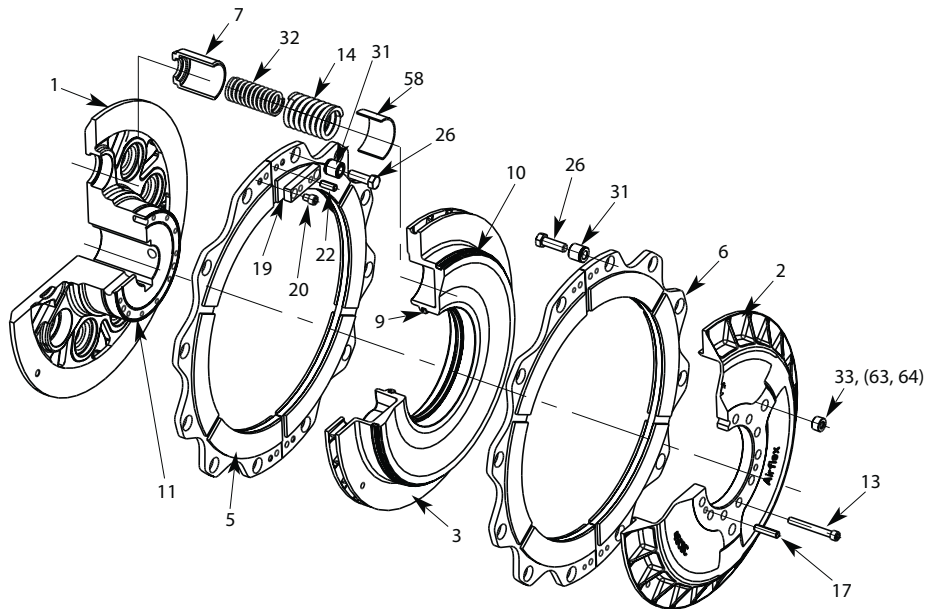

Long Arm Components

Sizes 5-25

Sizes 30-72

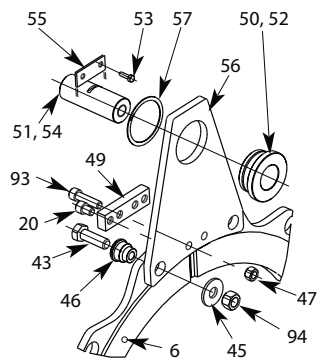
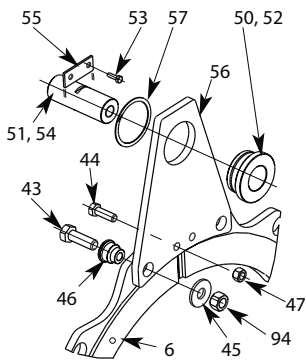

Short Arm Components

Sizes 5-25

Sizes 30-72

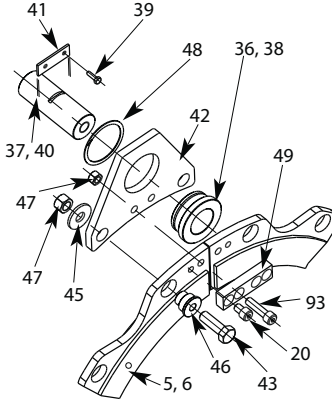
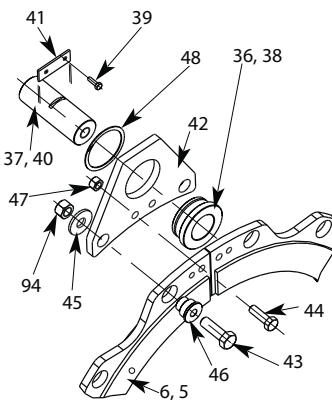

Item	Description
1	Hub
2	Cylinder
3	Piston
5	Clutch Friction Disc
6	Brake Friction Disc
7	Torque Tube
9	Piston Seal (ID)
10	Piston Seal (OD)
11	Face Seal
13	Socket Head Screw
14	Outer Spring
17	Spring Pin
19	Strap
20	Socket Head Screw
22	Spring Pin
26	Hex Head Screw

Item	Description
31	Bushing
32	Inner Spring
33	Plug
36	Short Arm Bushing (round)
37	Short Arm Reaction Pin (round)
38	Short Arm Bushing (rectangular)
39	Hex Head Screw
40	Short Arm Reaction Pin (square)
41	Retaining Plate
42	Short Reaction Arm
43	Hex Head Screw
44	Hex Head Screw
45	Washer
46	Bushing
47	Nut
48	Retaining Ring

Item	Description
49	Strap (sizes 30-72)
50	Long Arm Bushing (round)
51	Long Arm Reaction Pin (round)
52	Long Arm Bushing (rectangular)
53	Hex Head Screw
54	Long Arm Reaction Pin (square)
55	Retaining Plate
56	Long Arm Reaction Arm
57	Retaining Ring
58	Torque Tube Bushing
63	Quick release Valve (not shown)
64	Manual Release Screw (not shown)
93	Socket Head Screw
94	Nut

CBC Clutch/Brake Combination – Dimensional Data: BB Arrangement

Section F

English	Dimensions in inches												
30CBC	2.76	4.06	21.06	7.30	18.248	0.562	1.26	1.03	1.66	19.685	4.921	4.213	0.197
35CBC	3.07	4.06	22.44	7.84	19.606	0.719	1.48	1.07	1.86	21.102	5.512	4.724	0.197
40CBC	3.11	4.25	24.41	8.55	21.378	0.719	1.496	1.05	1.93	22.992	5.710	4.880	0.182
45CBC	3.50	4.57	26.77	9.34	23.346	0.750	1.673	1.20	2.25	25.197	6.300	5.300	0.243
50CBC	4.02	5.63	30.51	10.68	26.700	0.813	1.890	1.40	2.52	28.543	7.280	6.180	0.170
55CBC	4.45	6.30	34.06	11.94	29.850	0.813	2.165	1.63	2.91	31.890	8.070	6.970	0.305
Size	Dmin	Dmax ②	Da	D1	D2	d	G	G1	G2	K ①	L	M	S
30CBC	70	103	536	185	463	14	32	26	42	500	125	107	5
35CBC	78	103	570	199	498	18	37,5	27	48	536	140	120	5
40CBC	79	108	620	217	543	18	38	27	49	584	145	124	5
45CBC	89	116	680	237	593	19	42,5	31	57	640	160	135	6
50CBC	102	143	775	271	678	21	48	35	64	725	185	157	4
55CBC	113	160	865	303	758	21	55	41	74	810	205	177	8
SI	Dimensions in millimeters												

* Dimensions shown are for reference only. Consult factory for specific installation information.

Kit Description	Alpha Designation	CBC Size	Basic Part Number	Basic Kit Part Number
Bushing Kit	AA	30	108033	146487
Short Arm Kit	BB	35	108034	146488
Long Arm Kit	CC	40	108035	146489
Lining Kit	DD	45	108036	146490
Piston Seal Kit	FF	50	108037	146491
		55	108038	146492

Note:

- ① Tolerance: +0.004/-0.004 in.
+0.10/-0.10 mm
- ② Maximum bores are based on two flat English keys. Consult factory for other arrangements.

CBC Clutch/Brake Combination – Dimensional Data: BB Arrangement

Section F

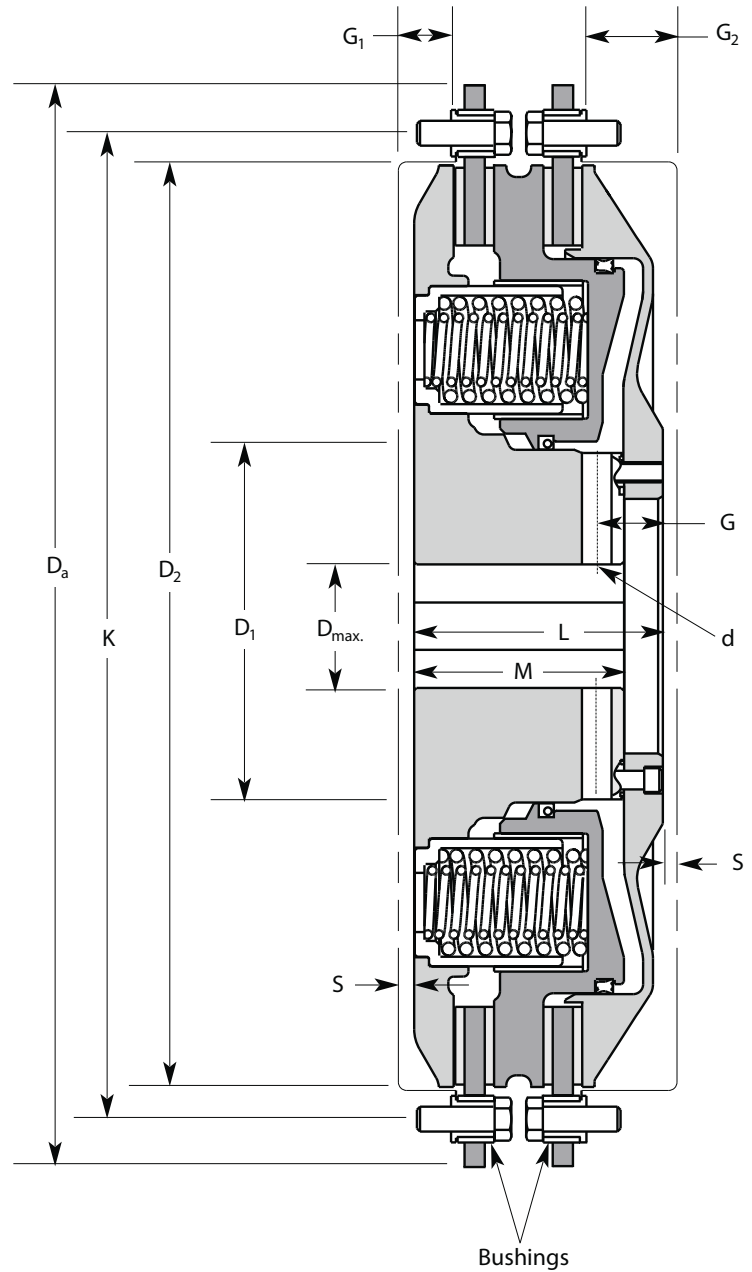
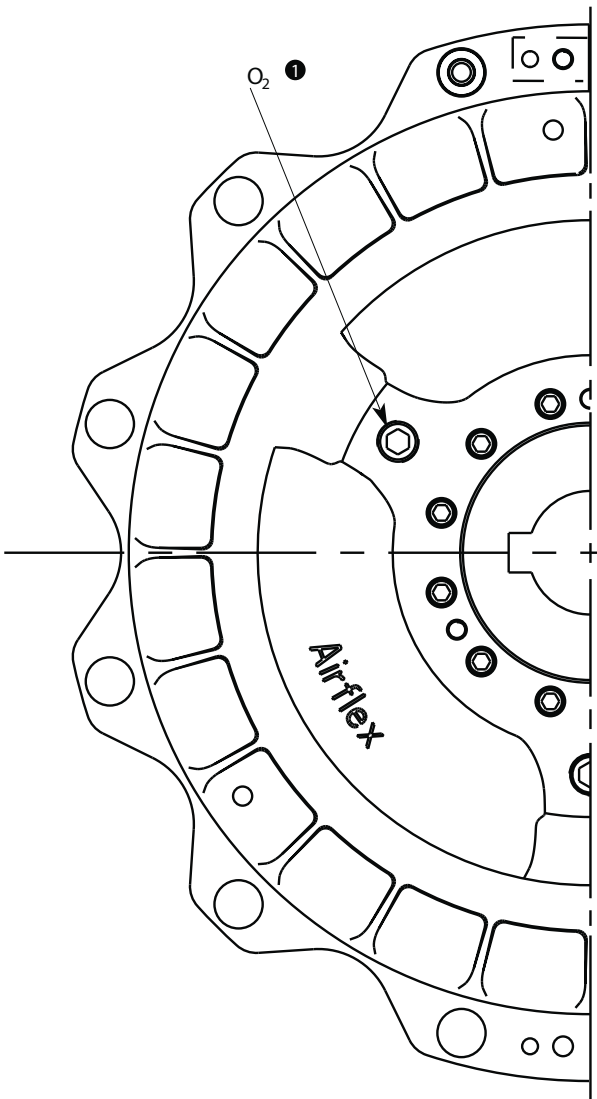

BB Arrangement

Size	Airflex Rotorseal Size
30 thru 45 CBC	1RH
50 & 55 CBC 1	1/4 RH

The standard CBC mounting arrangement utilizes 12 bushings (shown above) to guide each friction disc. The clutch friction disc bushings attach to the driving component. The brake friction disc bushings attach to a stationary reaction member. Optional mounting arrangements using arms and bushings are shown, as well as their mounting dimensions, on the following pages.

Note:

- 1 Consult factory for dimensional data.

CBC Clutch/Brake Combination – Optional Mounting Arrangements*

Section F

English	Dimensions in inches									
30CBC	24.016	31.102	27.36	33.66	19.685	5.16	2.598	4.85	1.25	0.51
35CBC	25.394	32.677	28.74	35.24	21.102	5.50	2.953	5.19	1.57	0.51
40CBC	27.362	34.843	30.71	37.40	22.992	5.98	3.228	5.57	1.77	0.59
45CBC	30.315	38.976	34.25	42.32	25.197	6.40	3.268	6.05	1.72	0.59
50CBC	34.646	44.685	39.37	48.62	28.543	7.28	3.858	6.86	2.04	0.59
55CBC	38.189	48.622	42.91	52.56	31.890	7.92	4.331	7.64	2.42	0.59
Size	A	A ₁	B	B ₁	K	L ₁	L ₂	L ₃	L ₄	O
30CBC	610	790	695	855	500	131	66	123	32	13
35CBC	645	830	730	895	536	140	75	132	40	13
40CBC	695	885	780	950	584	152	82	142	45	15
45CBC	770	990	870	1,075	640	162	83	154	44	15
50CBC	880	1,135	1,100	1,235	725	185	98	174	52	15
55CBC	970	1,235	1,090	1,335	810	201	110	194	61	15

SI Dimensions in millimeters

* Dimensions shown are for reference only. Consult factory for specific installation information.

Kit Description	Alpha Designation	CBC Size	Basic Part Number	Basic Kit Part Number
Bushing Kit	AA	30	108033	146487
Short Arm Kit	BB	35	108034	146488
Long Arm Kit	CC	40	108035	146489
Lining Kit	DD	45	108036	146490
Piston Seal Kit	FF	50	108037	146491
		55	108038	146492

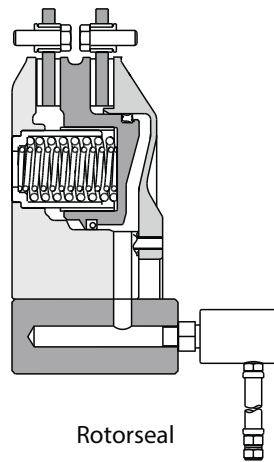

Rotorseal

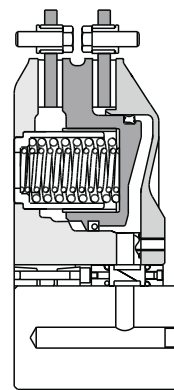

Locking Assembly and Seal

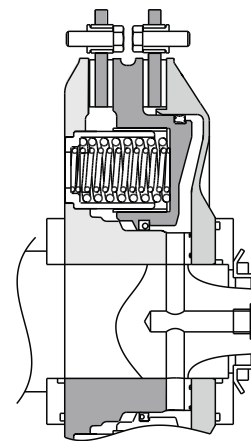

Face Seal

Alternate methods of sealing air supply between the clutch/brake housing and shaft.

CBC Clutch/Brake Combination – Optional Mounting Arrangements

Section F

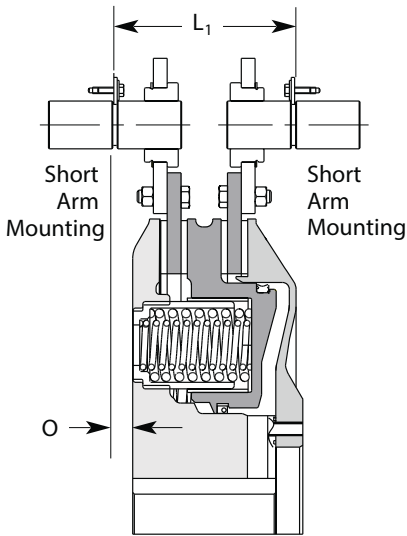

SS Arrangement

The clutch and brake friction discs each use two short arms for mounting. The arms are located 180° apart and are pin reacted.

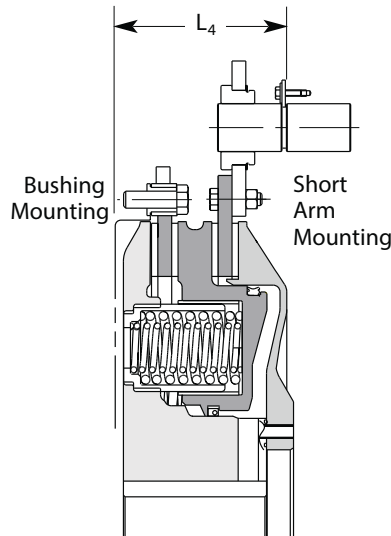

BS Arrangement

In this arrangement, twelve bushings are used for clutch friction disc mounting. Two short arms are used for mounting and reacting the brake friction disc.

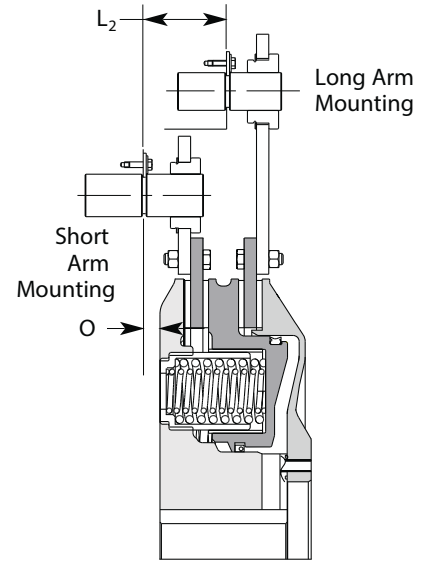

SL Arrangement

In this arrangement, a short pair of arms are used for mounting the clutch friction disc. A longer pair of arms are used for mounting and reacting the brake friction disc.

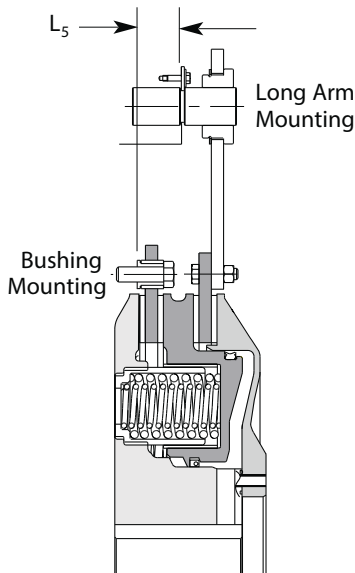

BL Arrangement

This arrangement uses twelve bushings for clutch friction disc mounting and two long arms for mounting and reacting the brake friction disc.

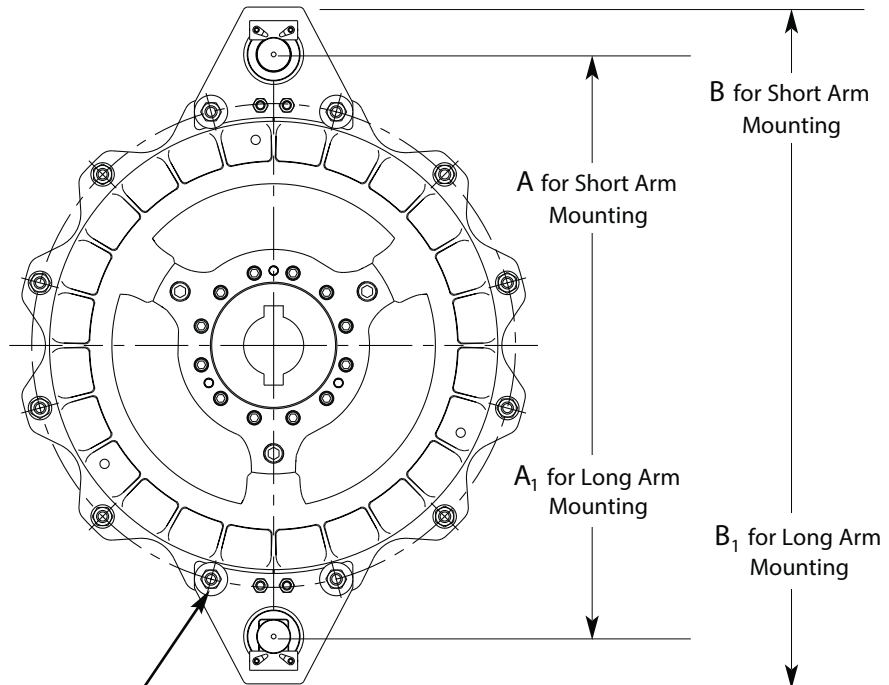

K Bolt Circle for
12 Bushing Mounting

CBC Clutch/Brake Combination – Bushing and Arm Mounting Dimensions*

Section F

Bushing Mounting Dimensions

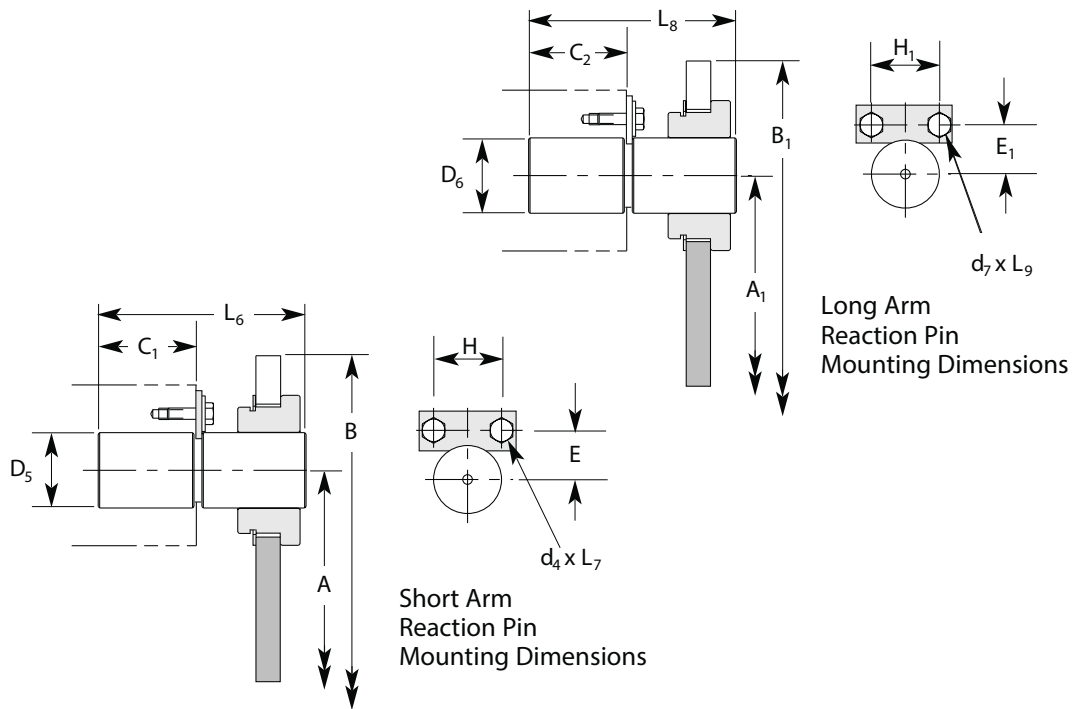
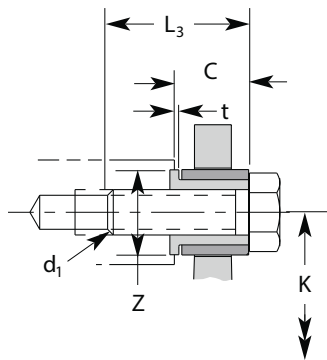

English	Dimensions in inches					
30	0.87	M14	1.58	0.12	19.68	0.99
35 & 40	1.06	M14	1.77	0.12	22.99	0.99
45	1.10	M16	1.97	0.20	25.20	1.19
50	1.38	M20	2.36	0.20	28.54	1.39
55	1.42	M24	2.76	0.20	31.89	1.61
Size	C	d1 ¹	L3	t	K	z
30	22	M14	40	3	500	25
35 & 40	27	M14	45	3	584	25
45	28	M16	50	5	640	30
50	35	M20	60	5	725	35
55	36	M24	70	5	810	41
SI	Dimensions in millimeters					

English	Dimensions in inches						
30-40	1.97	M6	1.57	1.06	1.38	4.33	0.79
45	2.36	M6	1.77	1.16	1.38	4.92	0.79
50 & 55	2.76	M8	2.17	1.52	1.77	5.51	0.98
Size	C1	d4 ¹	D5	E	H	L6	L7
30-40	50	M6	40	27	35	110	20
45	60	M6	45	29,5	35	125	20
50 & 55	70	M8	55	38,5	45	140	25

SI	Dimensions in millimeters						
English	Dimensions in inches						
45	1.97	M6	1.58	1.06	1.38	4.33	0.79
50 & 55	2.36	M6	1.77	1.16	1.38	4.92	0.79
60 & 66	2.76	M8	2.17	1.52	1.77	5.51	0.98
72	3.54	M8	2.56	1.75	1.77	7.68	0.98
Size	C2	d7 ¹	D6	E1	H1	L8	L9
5 & 10	20	M4	14	11	20	45	12
15 & 20	20	M4	14	11	20	45	12
25	35	M5	22	16	25	72	16
30-40	45	M5	30	20	25	90	16
45	50	M6	40	27	35	110	20
50 & 55	60	M6	45	30	35	125	20
SI	Dimensions in millimeters						

* Dimensions shown are for reference only. Consult factory for specific installation information.

Note:

- ¹ Metric Bolts

CBC Clutch/Brake Combination – Technical Data

Section F

English	Housing AllTypes	Clutch Disc BB, BS, BL	SS, SL	rpm	BB	SS	SL	BS	BL
30CBC	30.2	15	29	1200	165	195	196	180	183
35CBC	46	22	38	1100	210	240	245	225	230
40CBC	62	30	50	1000	255	290	290	270	275
45CBC	104	51	83	900	355	395	405	375	385
50CBC	191	95	173	800	530	605	620	570	585
55CBC	332	179	281	700	750	860	875	805	820
Size		Wk2 lb-ft2 J kg·m2		Max. Speed ❶				Weight lb Mass kg	
30CBC	1,3	0,625	1,225	1200	75	88	89	82	83
35CBC	2,0	0,925	1,60	1100	95	109	111	102	104
40CBC	2,75	1,25	2,08	1000	115	130	132	123	125
45CBC	4,63	2,13	3,50	900	160	179	183	170	174
50CBC	8,75	4,0	7,25	800	240	275	282	258	265
55CBC	15,0	7,5	11,8	700	340	390	397	365	372

* Dimensions shown are for reference only. Consult factory for specific installation information.

Note:

- ❶ Maximum speed for non-cyclic operation.
Maximum speed for single stroke operation is dependent upon clutch and brake thermal requirements.

CBC Clutch/Brake Combination – Torque Ratings (English Units)

Section F

CBC Size	No. of PS	No. of SS	Dynamic Brake Torque lb-in ❶	Brake Release Pressure psi	Static Clutch Torques (lb-in) at Various Pressures (psi) ❶						
					85 ❷	80	75	70	65	60	55
30	9	6	29,300	33	55,700	50,200	44,800	39,400	34,000	28,600	23,200
	9	9	32,900	37	51,100	45,700	40,300	34,900	29,500	24,100	18,700
	9	0	21,900	25	64,700	59,300	53,900	48,500	43,100	37,700	32,300
	0	9	10,900	12	78,300	72,900	67,500	62,100	56,700	51,300	45,900
35	9	6	37,500	33	70,500	63,600	56,700	49,900	43,000	36,100	29,200
	9	9	42,100	38	64,700	57,800	50,900	44,100	37,200	30,300	23,400
	9	0	28,100	25	82,100	75,200	68,300	61,500	54,600	47,700	40,800
	0	9	14,000	13	99,500	92,600	85,700	78,900	72,000	65,100	58,200
40	9	6	46,000	33	79,800	72,100	64,300	56,500	48,800	41,000	33,300
	9	9	51,800	37	73,300	65,600	57,800	50,100	42,300	34,600	26,800
	9	0	34,600	25	92,800	85,000	77,300	69,500	61,700	54,000	46,200
	0	9	17,200	12	112,400	104,700	96,900	89,100	81,400	73,600	65,900
45	9	6	66,600	33	115,000	104,000	93,000	81,000	70,000	59,000	48,000
	9	9	75,000	37	106,000	94,000	83,000	72,000	61,000	50,000	38,000
	9	0	50,000	25	134,000	123,000	111,000	100,000	89,000	78,000	66,000
	0	9	25,000	12	162,000	151,000	139,000	128,000	117,000	106,000	95,000
50	9	6	90,000	34	151,000	136,000	121,000	106,000	92,000	77,000	62,000
	9	9	101,300	38	138,000	124,000	109,000	94,000	79,000	64,000	50,000
	9	0	67,600	25	176,000	161,000	146,000	131,000	117,000	102,000	87,000
	0	9	33,600	13	213,000	199,000	184,000	169,000	154,000	140,000	125,000
55	9	6	120,000	33	206,000	186,000	166,000	146,000	126,000	106,000	86,000
	9	9	135,000	38	189,000	169,000	149,000	129,000	109,000	89,000	69,000
	9	0	90,000	25	240,000	220,000	200,000	180,000	160,000	139,000	119,000
	0	9	45,000	13	290,000	270,000	250,000	230,000	210,000	190,000	170,000

❶ Ratings are with new linings. Reduce clutch torque by 10% and brake torque by 15% for fully worn linings. ❷ Maximum allowable pressure 100 psi.

CBC Clutch/Brake Combination – Torque Ratings (Metric Units)

Section F

CBC Size	No. of PS	No. of SS	Dynamic Brake Torque N-m ❶	Brake Release Pressure bar	Static Clutch Torques (N-m) at Various Pressures (bar)						
					6 ❷	5,5	4	4,5	4	3,5	3
30	9	6	3310	2,29	6293	5672	5062	4451	3841	3231	2621
	9	9	3717	2,58	5773	5163	4553	3943	3333	3723	2113
	9	0	2474	1,72	7310	6700	6090	5480	4870	4259	3649
	0	9	1231	0,86	8846	8236	7626	7016	6406	5796	5186
35	9	6	4237	2,30	7965	7186	6406	5638	4858	4079	3299
	9	9	4757	2,59	7310	6530	5751	4982	4203	3423	2644
	9	0	3175	1,73	9276	8496	7717	6948	6169	5389	4610
	0	9	1582	0,86	11242	10462	9683	8914	8135	7355	6576
40	9	6	5197	2,28	9016	8146	7265	6383	5514	4632	3762
	9	9	5852	2,56	8282	7412	6530	5660	4779	3909	2028
	9	0	3909	1,71	10485	9603	8733	7852	6971	6101	5220
	0	9	1943	0,85	12699	11829	10948	10067	9197	8315	7445
45	9	6	7525	2,28	12993	11750	10507	9152	7909	6666	5423
	9	9	8474	2,56	11976	10620	9377	8135	6892	5649	4293
	9	0	5649	1,71	15140	13897	12541	11298	10055	8813	7457
	0	9	2825	0,85	18303	17060	15704	14462	13219	11976	10733
50	9	6	10168	2,33	17060	15365	13671	11976	10394	8700	7005
	9	9	11445	2,63	155591	14010	12315	10620	8926	7231	5649
	9	0	7638	1,75	19885	18190	16495	14801	13219	11524	9829
	0	9	3796	0,87	24065	22483	20789	19094	17399	15817	14123
55	9	6	13558	2,31	23274	21015	18755	16495	14236	11976	9716
	9	9	15253	2,60	21354	19094	16834	14575	12315	10055	7796
	9	0	10168	1,73	27116	24856	22596	20337	18077	15704	13445
	0	9	5084	0,87	32765	30505	28245	25986	23726	21467	19207

❶ Ratings are with new linings. Reduce clutch torque by 10% and brake torque by 15% for fully worn linings. ❷ Maximum allowable pressure 6.9 psi.

Airflex® FSPA Package Description

Section F

Description

The press application flywheel clutch/brake package is designed primarily for stamping press applications. However, it can be easily adapted to other types of flywheel machines requiring cyclic operation. The major components of the package are:

1. An Airflex CB or VC clutch element.
2. An Airflex CS, CSA or CTE spring-applied air-released brake.
3. A flywheel or bullgear with anti-friction bearings.
4. Clutch and brake drums.
5. Airflex quick release valves.
6. An Airflex rotorseal.

The combination or separate clutch and brake drums are keyed to the driven shaft. The bearing mounted flywheel or bullgear rides on the outside diameter of the clutch drum hub. The clutch element is attached to the flywheel or bullgear. The brake is attached to and reacted by the machine frame.

Operating air is introduced through a standard Airflex rotorseal. Air to engage the clutch simultaneously releases the brake, allowing the driven shaft to rotate. When air pressure is released, air from the clutch exhausts through the quick release valves. The spring-applied brake engages, stopping the driven shaft.

The most frequently used mounting arrangement includes a combination clutch and brake drum as illustrated in the components parts figure. An alternate arrangement provides separate drums for the clutch and brake allowing the brake to be mounted at any convenient point along the driven shaft.

The flywheel can be grooved for drive belts and furnished with barring holes to facilitate die set-up for stamping presses. An optional bumping pin can be provided to mechanically connect the flywheel and clutch drum for manually freeing a stuck press die. Gear teeth can be provided in the flywheel blank for crankshaft mounting the package on geared presses.

An Airflex rotorseal is furnished with the standard package. Units are available in a large variety of sizes and mounting arrangements with clutch torques to 320000 lb·in (36200 N·m).

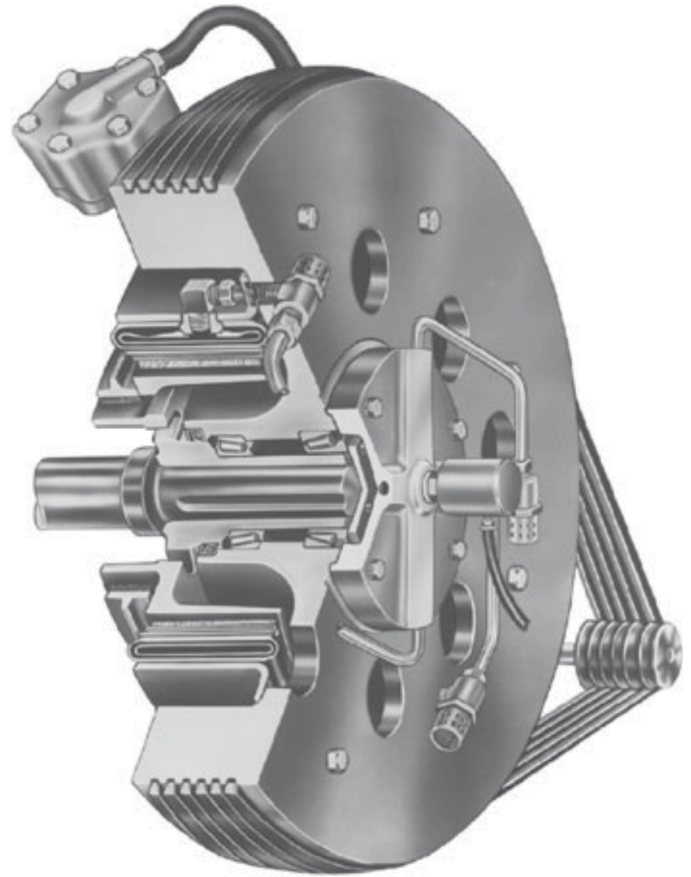

Where Used:

- Can making machines
- Press brakes
- Shears
- Stamping and forming presses

Airflex® Press Application

Section F

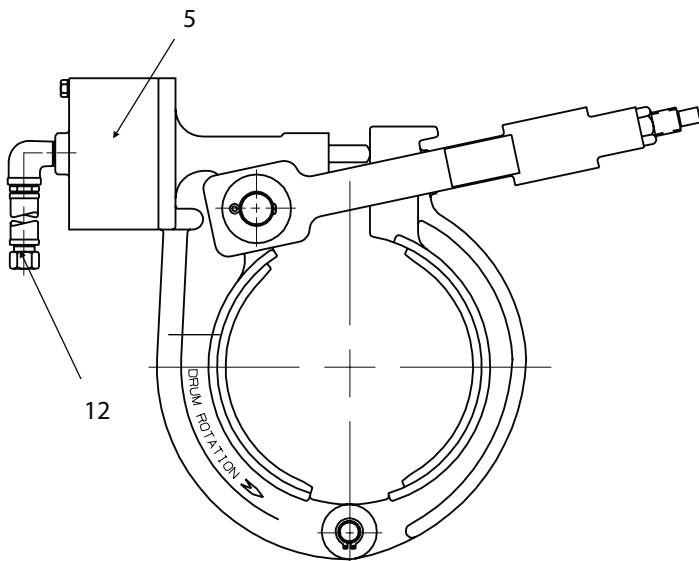
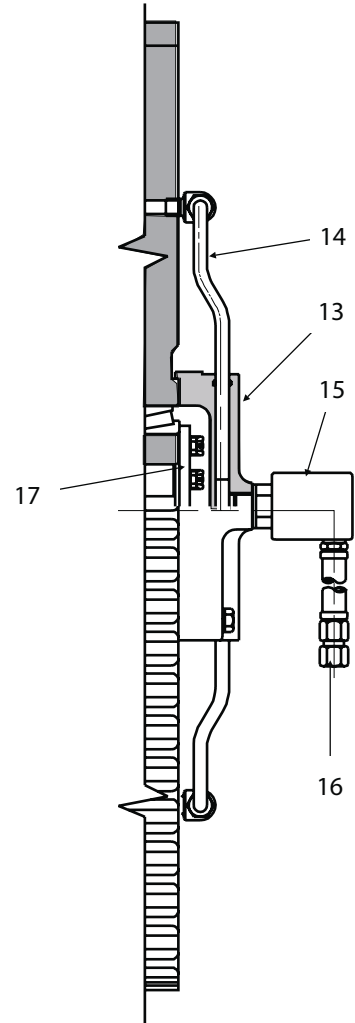
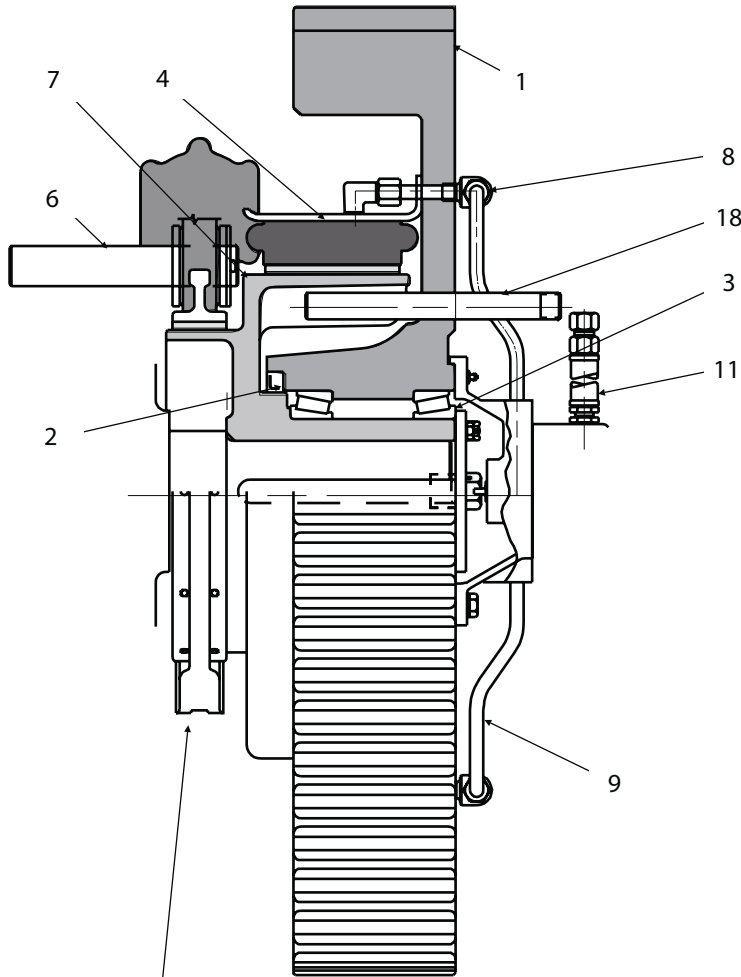

Item	Description
1	Flywheel or Bullgear
2	Oil Seal
3	Bearing
4	Clutch
5	Brake
6	Brake Reaction Pin
7	Clutch and Brake Drum
8	Quick Release Valve
9	Rotorseal Air Tube
11	Rotorseal Air Hose
12	Brake Air Hose
13	Rotorseal Adapter
14	Rotorseal Air Tube
15	Rotorseal
16	Rotorseal Air Hose
17	End Plate
18	Optional Bumping Pin

Airflex® Press Application Packages having CB Clutch Elements

Section F, Form PP 301 — Technical Data

English	lb · ft ²	lb	rpm	lb	in	
L1	9	34	1700	85	2.7	104776
00	18	46	1430	150	3.7	104777
0	41	68	1150	190	3.8	104778
01	41	68	1150	210	3.8	104779
1	106	138	950	350	4.3	104780
2	239	235	850	460	4.3	104781
103	239	235	820	500	4.6	104782
104	424	309	740	620	4.6	104783
105	942	522	640	890	4.6	104784
6	424	309	715	690	5.9	104785
7	942	522	640	950	5.9	104786
8	1604	705	570	1250	5.9	104787
109	942	522	570	1070	5.6	104788
110	1604	705	570	1370	5.6	104789
111	2415	825	510	1450	5.6	104790
112	1604	705	480	1440	5.8	104791
113	2415	825	480	1660	5.8	104792
114	4238	1170	460	2190	5.8	104793
115	2415	825	410	1770	5.6	104794
116	4238	1170	410	2300	5.6	104795
117	6630	1456	410	2750	5.6	104796
118	4238	1170	360	2490	5.8	106995
119	6630	1456	360	2940	5.9	106996
120	11331	2028	360	3690	6.5	106997
121	6630	1456	320	3080	5.4	107000
122	11331	2028	320	3790	6.2	107001
Press Application Size	Flywheel Rim		① Maximum Speed	Weight Mass	D ₃₇	② Part Number w/Rotorseal
	Wk ² J	Weight Mass				
L1	0,38	15	1700	39	69	104776
00	0,76	21	1430	68	94	104777
0	1,72	31	1150	86	97	104778
01	1,72	31	1150	95	97	104779
1	4,45	63	950	159	109	104780
2	10,04	106	850	208	109	104781
103	10,04	106	820	227	117	104782
104	17,81	140	740	281	117	104783
105	39,56	236	640	403	117	104784
6	17,81	140	715	313	150	104785
7	39,56	236	640	430	150	104786
8	67,37	319	570	566	150	104787
109	39,56	236	570	485	142	104788
110	67,37	319	570	621	142	104789
111	101,4	374	510	657	142	104790
112	67,37	319	480	652	147	104791
113	101,4	374	480	752	147	104792
114	178,0	530	460	992	147	104793
115	101,4	374	410	802	142	104794
116	178,0	530	410	1042	142	104795
117	278,5	660	410	1246	142	104796
118	178,0	530	360	1128	147	106995
119	278,5	660	360	1332	150	106996
120	475,9	919	360	1672	165	106997
121	278,5	660	320	1395	137	107000
122	475,9	919	320	1717	157	107001
SI	kg · m ²	kg	rpm	kg	mm	

Airflex® Press Application Packages having CB Clutch Elements

Section F

Form PP 301 — Technical Data

English	lb · in @ 75 psi	lb · in	lb · ft ²	in ²	in ³	Model		
L1	2040	3000	0.4	36	9	30	6CB200	4CS150
00 & 0	4290	6000	1.4	61	20	55	8CB250	6CSA200
01	8150	6000	3	91	20	75	10CB300	6CSA200
1 & 2	13300	13000	8	128	33	105	12CB350	9CSA200
103, 104, 105	19700	13000	13	170	33	95	14CB400	9CSA200
6, 7, 8	35200	18000	28	241	45	165	16CB500	12CSA200
109, 110, 111	53600	22000	61	288	89	210	20CB500	15CS300
112, 113, 114	75000	27000	115	338	108	245	24CB500	18CS300
115, 116, 117	106000	27000	178	430	108	325	28CB525	18CS300
118, 119, 120	137000	111200	365	483	328	410	32CB525	24CTE500
121, 122	172000	111200	451	550	328	450	36CB525	24CTE500
Size	③ Clutch Torque	Forward Brake Torque	Drum	Friction Area	④ Air Volume	Clutch Size	Brake Size	
			Wk ²	Clutch	Brake			
			J	Clutch	Brake			
L1	231	339	0,02	232	58	0,5	6CB200	4CS150
00 & 0	485	678	0,06	393	129	0,9	8CB250	6CSA200
01	921	678	0,13	587	129	1,2	10CB300	6CSA200
1 & 2	1500	1470	0,34	826	213	1,7	12CB350	9CSA200
103, 104, 105	2230	1470	0,55	1097	213	1,6	14CB400	9CSA200
6, 7, 8	3980	2030	1,18	1554	290	2,7	16CB500	12CSA200
109, 110, 111	6060	2490	2,56	1858	574	3,4	20CB500	15CS300
112, 113, 114	8480	3050	4,83	2180	697	4,0	24CB500	18CS300
115, 116, 117	12000	3050	7,48	2774	697	5,3	28CB525	18CS300
118, 119, 120	15500	12600	15,33	3115	2116	6,7	32CB525	24CTE500
121, 122	19400	12600	18,94	3548	2116	7,4	36CB525	24CTE500
Size	N · m @ 5,2 bar	N · m	kg · m ²	cm ²	dm ³	Model		

Notes:

- ① Maximum speed for non-cyclic operation. Maximum speed for single stroke operation is dependent upon clutch and brake thermal requirements.
- ② Basic part number only. Complete part number is dependent upon bore direction of rotation and optional features.
- ③ Clutch torque dependent upon operating pressure and speed. See Section B for torque adjustment.
- ④ Absolute volume required per engagement.

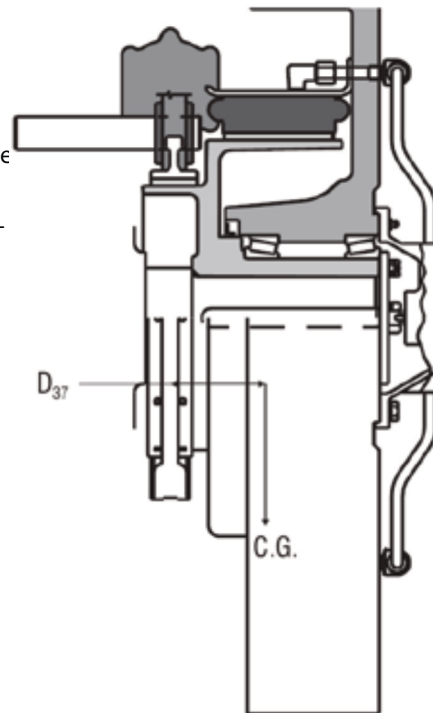

Airflex® Press Application Packages having CB Clutch Elements

Section F, Form PP 301 — Dimensional Data

English	Dimensions in inches												
L1	1.250	1.13	1.50	11.44	6.91	6.13	3.00	6.38	2.31	3.56	13.50	0.749	11.38
00	2.000	1.44	2.00	12.06	8.25	7.38	3.00	5.28	2.25	5.00	16.00	0.999	13.50
0	2.000	1.44	2.00	12.06	8.25	7.38	3.00	5.28	2.25	5.00	20.00	0.999	17.00
01	2.000	1.44	2.00	12.69	8.88	8.00	3.00	5.28	2.88	5.00	20.00	0.999	17.00
1	2.000	1.75	3.00	14.53	9.75	8.88	4.00	5.41	2.63	6.13	23.00	1.249	19.00
2	2.000	1.75	3.00	14.53	9.75	8.88	4.00	5.41	2.63	6.13	27.00	1.249	21.00
103	2.375	1.75	3.00	15.47	10.69	9.81	4.00	5.41	3.06	6.63	27.00	1.249	21.00
104	2.375	1.75	3.00	15.47	10.69	9.81	4.50	5.41	3.06	6.63	31.00	1.249	25.00
105	2.375	1.75	3.00	15.47	10.69	9.81	5.00	5.41	3.06	6.63	36.00	1.249	28.00
6	3.000	2.63	3.75	16.63	11.75	10.75	4.50	6.47	2.25	8.38	31.00	1.499	25.00
7	3.000	2.63	3.75	16.63	11.75	10.75	5.00	6.47	2.25	8.38	36.00	1.499	28.00
8	3.000	2.63	3.75	16.63	11.75	10.75	6.00	6.47	2.25	8.38	40.00	1.499	32.00
109	3.250	3.00	3.50	16.63	13.25	12.13	5.00	6.47	3.50	8.50	36.00	1.499	28.00
110	3.250	3.00	3.50	16.63	13.25	12.13	6.00	6.47	3.50	8.50	40.00	1.499	32.00
111	3.250	3.00	3.50	16.63	13.25	12.13	6.00	6.47	3.50	8.50	45.00	1.499	36.75
112	3.625	3.00	4.00	16.88	13.50	12.38	6.00	6.59	3.50	8.75	40.00	1.499	32.00
113	3.625	3.00	4.00	16.88	13.50	12.38	6.00	6.59	3.50	8.75	45.00	1.499	36.75
114	3.625	3.00	4.00	16.88	13.50	12.38	7.00	6.59	3.50	8.75	50.00	1.499	41.00
115	4.125	3.00	4.25	17.53	14.25	13.13	6.00	6.59	4.25	8.75	45.00	1.499	36.75
116	4.125	3.00	4.25	17.53	14.25	13.13	7.00	6.59	4.25	8.75	50.00	1.499	41.00
117	4.125	3.00	4.25	17.53	14.25	13.13	7.00	6.59	4.25	8.75	56.00	1.499	46.00
118	4.500	3.25	4.75	24.06	17.31	16.69	7.00	7.78	7.38	10.38	50.00	1.998	41.00
119	4.500	3.25	4.75	24.06	17.31	16.69	7.00	7.78	7.38	10.38	56.00	1.998	46.00
120	4.500	3.25	4.75	25.25	18.50	17.88	8.00	7.78	7.38	10.38	62.00	1.998	51.00
121	4.750	3.25	4.75	24.06	17.31	16.69	7.00	7.78	7.38	10.38	56.00	1.998	46.00
122	4.750	3.25	4.75	25.25	18.50	17.88	8.00	7.78	7.38	10.38	62.00	1.998	51.00
Press Application Size	Bore Range			D	D ₁₁	D ₁₂	D ₁₃	D ₁₅	D ₁₉	D ₂₂	H	H ₃	H ₅
	Standard	Min.	Max.										
L1	31,8	29	38	291	175	156	76	162	59	90	343	19,0	289
00	50,8	37	51	306	210	187	76	134	57	127	406	25,4	343
0	50,8	37	51	306	210	187	76	134	57	127	508	25,4	432
01	50,8	37	51	322	225	203	76	134	73	127	508	25,4	432
1	50,8	44	76	369	248	225	102	137	67	156	584	31,7	483
2	50,8	44	76	369	248	225	102	137	67	156	686	31,7	533
103	60,3	44	76	393	271	249	102	137	78	168	686	31,7	533
104	60,3	44	76	393	271	249	114	137	78	168	787	31,7	635
105	60,3	44	76	393	271	249	127	137	78	168	914	31,7	711
6	76,2	67	95	422	298	273	114	164	57	213	787	38,1	635
7	76,2	67	95	422	298	273	127	164	57	213	914	38,1	711
8	76,2	67	95	422	298	273	152	164	57	213	1016	38,1	813
109	82,6	76	89	422	337	308	127	164	89	216	914	38,1	711
110	82,6	76	89	422	337	308	152	164	89	216	1016	38,1	813
111	82,6	76	89	422	337	308	152	164	89	216	1143	38,1	933
112	92,1	76	102	429	343	314	152	167	89	222	1016	38,1	813
113	92,1	76	102	429	343	314	152	167	89	222	1143	38,1	933
114	92,1	76	102	429	343	314	178	167	89	222	1270	38,1	1041
115	104,8	76	108	445	362	333	152	167	108	222	1143	38,1	933
116	104,8	76	108	445	362	333	178	167	108	222	1270	38,1	1041
117	104,8	76	108	445	362	333	178	167	108	222	1422	38,1	1168
118	114,3	83	121	611	440	424	178	198	187	264	1270	50,7	1041
119	114,3	83	121	611	440	424	178	198	187	264	1422	50,7	1168
120	114,3	83	121	641	470	454	203	198	187	264	1575	50,7	1295
121	120,7	83	121	611	440	424	178	198	187	264	1422	50,7	1168
122	120,7	83	121	641	470	454	203	198	187	264	1575	50,7	1295
SI	Dimensions in millimeters												

Airflex® Press Application Packages having CB Clutch Elements

Section F

Form PP 301 — Dimensional Data

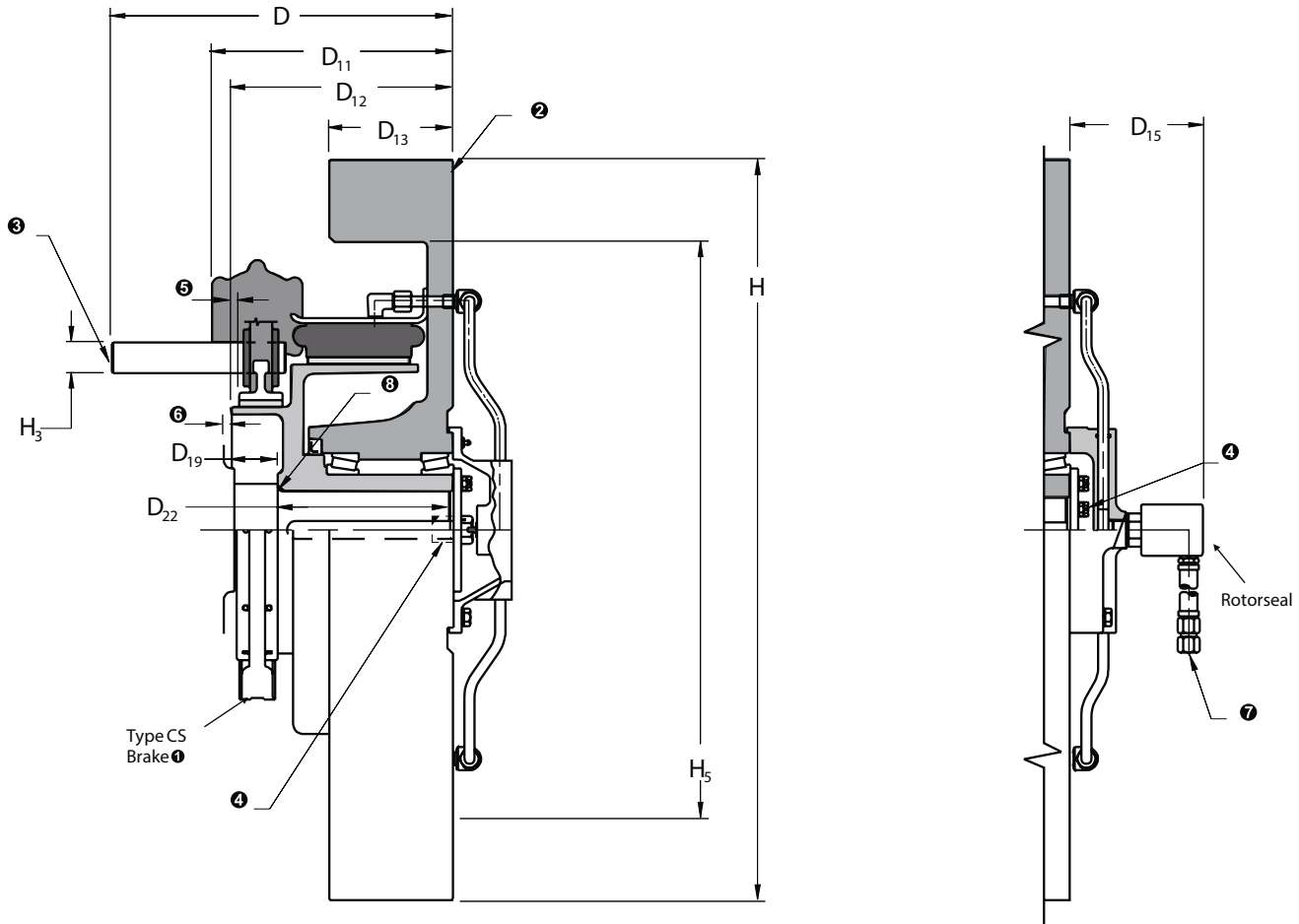

Notes:

- ❶ Refer to Section G for brake dimensional data.
- ❷ Optional belt grooving or gear teeth can be machined in the flywheel rim at additional cost.
- ❸ Customer to locate and mount reaction pin.
- ❹ 0.25 in (6 mm) for size L1. 0.38 in (10 mm) for all other sizes.
- ❺ 0.38 in (10 mm) minimum, all sizes.

- ❻ Shaft radius 0.06 in (1,5 mm) for size L1; 0.25 in (6 mm) for all other sizes.
- ❼ Tolerance +0.001/-0.000 in (+0,03/-0,00 mm).

Airflex® Press Application Packages having VC Clutch Elements

Section F

Form PP 305 — Technical Data

English	lb · ft ²	lb	rpm	lb	in	
1127	239	235	850	525	5.3	104802
1131	424	309	740	650	4.3	104803
1136	942	522	640	915	4.3	104804
1431	424	309	740	765	5.6	104805
1436	942	522	640	1030	5.7	104806
1440	1604	705	570	1320	5.6	104807
1445	2415	825	510	1540	5.8	104808
1636	942	522	640	1080	5.4	104809
1640	1604	705	570	1370	5.5	104810
1645	2415	825	510	1590	5.6	104811
1650	4238	1170	460	2075	5.5	104812
2040	1604	705	570	1425	5.7	104813
2045	2415	825	510	1650	5.9	104814
2050	4238	1170	460	2175	5.8	104815
2056	6630	1456	410	2620	5.9	104816
2445	2415	825	480	1715	5.6	104817
2450	4238	1170	460	2415	5.4	104818
2456	6630	1456	410	2750	5.7	104819
2850	4238	1170	410	2685	6.6	104820
2856	6630	1456	410	3260	6.8	104821
2862	11331	2028	370	4080	6.6	104822
2868	20695	3300	340	4690	6.5	104823
3356	6630	1456	350	3465	6.5	104824
3362	11331	2028	350	4360	6.4	104825
3368	20695	3300	340	5640	6.3	104826
3762	11331	2028	310	4455	6.3	104827
3768	20695	3300	310	5735	6.2	104828

Press Application Size	Flywheel Rim	Wk ²	Weight	Maximum Speed	Weight		Part Number
					Mass	D ₃₇	
		J	Mass				
1127		10,04	106	850	238	135	104802
1131		17,81	140	740	294	109	104803
1136		39,56	236	640	414	109	104804
1431		17,81	140	740	347	142	104805
1436		39,56	236	640	467	145	104806
1440		67,37	319	570	598	142	104807
1445		101,4	374	510	698	147	104808
1636		39,56	236	640	489	137	104809
1640		67,37	319	570	621	140	104810
1645		101,4	374	510	720	142	104811
1650		178,0	530	460	940	140	104812
2040		67,37	319	570	646	145	104813
2045		101,4	374	510	747	150	104814
2050		178,0	530	460	985	147	104815
2056		278,5	660	410	1187	150	104816
2445		101,4	374	480	777	142	104817
2450		178,0	530	460	1094	137	104818
2456		278,5	660	410	1246	145	104819
2850		178,0	530	410	1216	168	104820
2856		278,5	660	410	1477	173	104821
2862		475,9	919	370	1848	168	104822
2868		869,2	1495	340	2125	165	104823

Airflex® Press Application Packages having VC Clutch Elements

Section F

Form PP 305 — Technical Data

FSPA Size	Flywheel Rim	Wk ²		① Maximum Speed	Weight		D ₃₇	② Part Number
		J	Mass		Mass	kg		
3356	278,5	660	350	1570	165	104824		
3362	475,9	919	350	1975	163	104825		
3368	869,2	1495	340	2555	160	104826		
3762	475,9	919	310	2018	160	104827		
3768	869,2	1495	310	2598	157	104828		
SI	kg · m ²	kg	rpm	kg	mm			

English	lb · in	lb · ft ²	in ²	in ³	
1127 thru 1136	27000	8	166	70	11.5VC500
1431 thru 1445	39000	14	205	95	14VC500
1636 thru 1650	65000	28	283	120	16VC600
2040 thru 2056	93000	61	380	140	20VC600
2445 thru 2456	135000	105	466	200	24VC650
2850 thru 2868	182000	180	548	270	28VC650
3356 thru 3368	255000	370	643	360	33VC650
3762 thru 3768	320000	670	720	400	37VC650

Press Application Size	③ Clutch Torque	Drum	Friction Area	④ Air Volume	Clutch Size
1127 thru 1136	3050	0,34	1071	1,15	11.5VC500
1431 thru 1445	4410	0,59	1322	1,56	14VC500
1636 thru 1650	7350	1,18	1825	1,97	16VC600
2040 thru 2056	10500	2,56	2451	2,30	20VC600
2445 thru 2456	15300	4,41	3006	3,28	24VC650
2850 thru 2868	20600	7,56	3535	4,43	28VC650
3356 thru 3368	28800	15,54	4147	5,90	33VC650
3762 thru 3768	36200	28,14	4644	6,56	37VC650
SI	N · m	kg · m ²	cm ²	dm ³	

Notes:

- ① Maximum speed for non-cyclic operation. Maximum speed for single stroke operation is dependent upon clutch and brake thermal requirements.
- ② Basic part number only. Complete part number is dependent upon bore and optional features.
- ③ Clutch torque dependent upon operating pressure and speed. See Section B for torque adjustment.
- ④ Absolute volume required per engagement. Brake releasing volume must be added.

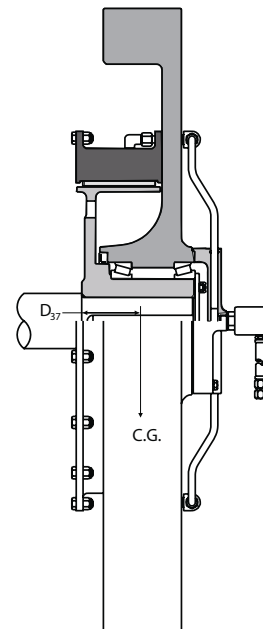

Airflex® Press Application Packages having VC Clutch Elements

Section F, Form PP 305 — Dimensional Data

English	Dimensions in inches										
1127	2.500	2.00	3.00	7.75	1.00	7.38	4.00	5.41	6.63	27.00	21.00
1131	2.500	2.00	3.00	7.88	1.13	7.50	4.50	5.41	6.63	31.00	25.00
1136	2.500	2.00	3.00	8.00	1.25	7.63	5.00	5.41	6.63	36.00	28.00
1431	3.000	1.75	3.00	8.88	0.38	7.56	4.50	6.47	8.38	31.00	25.00
1436	3.000	1.75	3.00	8.88	0.38	7.68	5.00	6.47	8.38	36.00	28.00
1440	3.000	1.75	3.00	8.88	0.38	7.94	6.00	6.47	8.38	40.00	32.00
1445	3.000	1.75	3.00	8.88	0.38	7.94	6.00	6.47	8.38	45.00	36.75
1636	3.500	2.50	3.75	9.31	1.06	8.94	5.00	6.47	8.38	36.00	28.00
1640	3.500	2.50	3.75	9.56	1.31	9.19	6.00	6.47	8.38	40.00	32.00
1645	3.500	2.50	2.50	9.56	1.31	9.19	6.00	6.47	8.38	45.00	36.75
1650	3.500	2.50	2.50	9.69	1.44	9.31	7.00	6.47	8.38	50.00	41.00
2040	4.000	3.00	4.00	9.56	0.69	9.19	6.00	6.44	8.75	40.00	32.00
2045	4.000	3.00	4.00	9.56	0.69	9.19	6.00	6.44	8.75	45.00	36.75
2050	4.000	3.00	4.00	9.81	0.94	9.44	7.00	6.44	8.75	50.00	41.00
2056	4.000	3.00	4.00	9.81	0.94	9.44	7.00	6.44	8.75	56.00	46.00
2445	4.500	3.75	4.75	9.94	1.00	9.56	6.00	7.78	10.00	45.00	36.75
2450	4.500	3.75	4.75	10.19	1.25	9.81	7.00	7.78	10.00	50.00	41.00
2456	4.500	3.75	4.75	10.19	1.25	9.81	7.00	7.78	10.00	56.00	46.00
2850	5.000	4.75	5.50	10.38	0.38	9.81	7.00	12.50	11.88	50.00	41.00
2856	5.000	4.75	5.50	10.38	0.38	10.06	7.00	12.50	11.88	56.00	46.00
2862	5.000	4.75	5.50	10.38	0.38	10.06	8.00	12.50	11.88	62.00	51.00
2868	5.000	4.75	5.50	10.38	0.38	10.06	8.00	12.50	11.88	68.00	51.00
3356	5.500	4.75	6.00	10.53	0.59	10.16	7.00	12.50	11.81	56.00	46.00
3362	5.500	4.75	6.00	10.53	0.59	10.16	8.00	12.50	11.81	62.00	51.00
3368	5.500	4.75	6.00	10.53	0.59	10.16	8.00	12.50	11.81	68.00	51.00
3762	6.000	5.50	6.50	10.53	0.53	10.16	8.00	12.50	11.88	62.00	51.00
3768	6.000	5.50	6.50	10.53	0.53	10.16	8.00	12.50	11.88	68.00	51.00
Press Application Size	Bore Range			D _{min}	D _{ref}	D ₁₂	D ₁₃	D ₁₅	D ₂₂	H	H _s
	Standard	Min.	Max.								
1127	63,5	51	76	197	25	187	102	137	168	686	533
1131	63,5	51	76	200	29	191	114	137	168	787	635
1136	63,5	51	76	203	32	194	127	137	168	914	711
1431	76,2	44	76	225	10	192	114	164	213	787	635
1436	76,2	44	76	225	10	195	127	164	213	914	711
1440	76,2	44	76	225	10	202	152	164	213	1016	813
1445	76,2	44	76	225	10	202	152	164	213	1143	933
1636	88,9	64	95	237	27	227	127	164	213	914	711
1640	88,9	64	95	243	33	233	152	164	213	1016	813
1645	88,9	64	64	243	33	233	152	164	213	1143	933
1650	88,9	64	64	246	37	237	178	164	213	1270	1041
2040	101,6	76	102	243	18	233	152	164	222	1016	813
2045	101,6	76	102	243	18	233	152	164	222	1143	933
2050	101,6	76	102	249	24	240	178	164	222	1270	1041
2056	101,6	76	102	249	24	240	178	164	222	1422	1168
2445	114,3	95	121	252	25	243	152	198	254	1143	933
2450	114,3	95	121	259	32	249	178	198	254	1270	1041
2456	114,3	95	121	259	32	249	178	198	254	1422	1168
2850	127,0	121	140	264	10	249	178	318	302	1270	1041
2856	127,0	121	140	264	10	256	178	318	302	1422	1168
2862	127,0	121	140	264	10	256	203	318	302	1575	1295
2868	127,0	121	140	264	10	256	203	318	302	1727	1295
3356	139,7	121	152	267	15	258	178	318	300	1422	1168
3362	139,7	121	152	267	15	258	203	318	300	1575	1295
3368	139,7	121	152	267	15	258	203	318	300	1727	1295
3762	152,4	140	165	267	13	258	203	318	302	1575	1295
3768	152,4	140	165	267	13	258	203	318	302	1727	1295
SI	Dimensions in millimeters										

Airflex® Press Application Packages having VC Clutch Elements

Section F

Form PP 305 — Dimensional Data

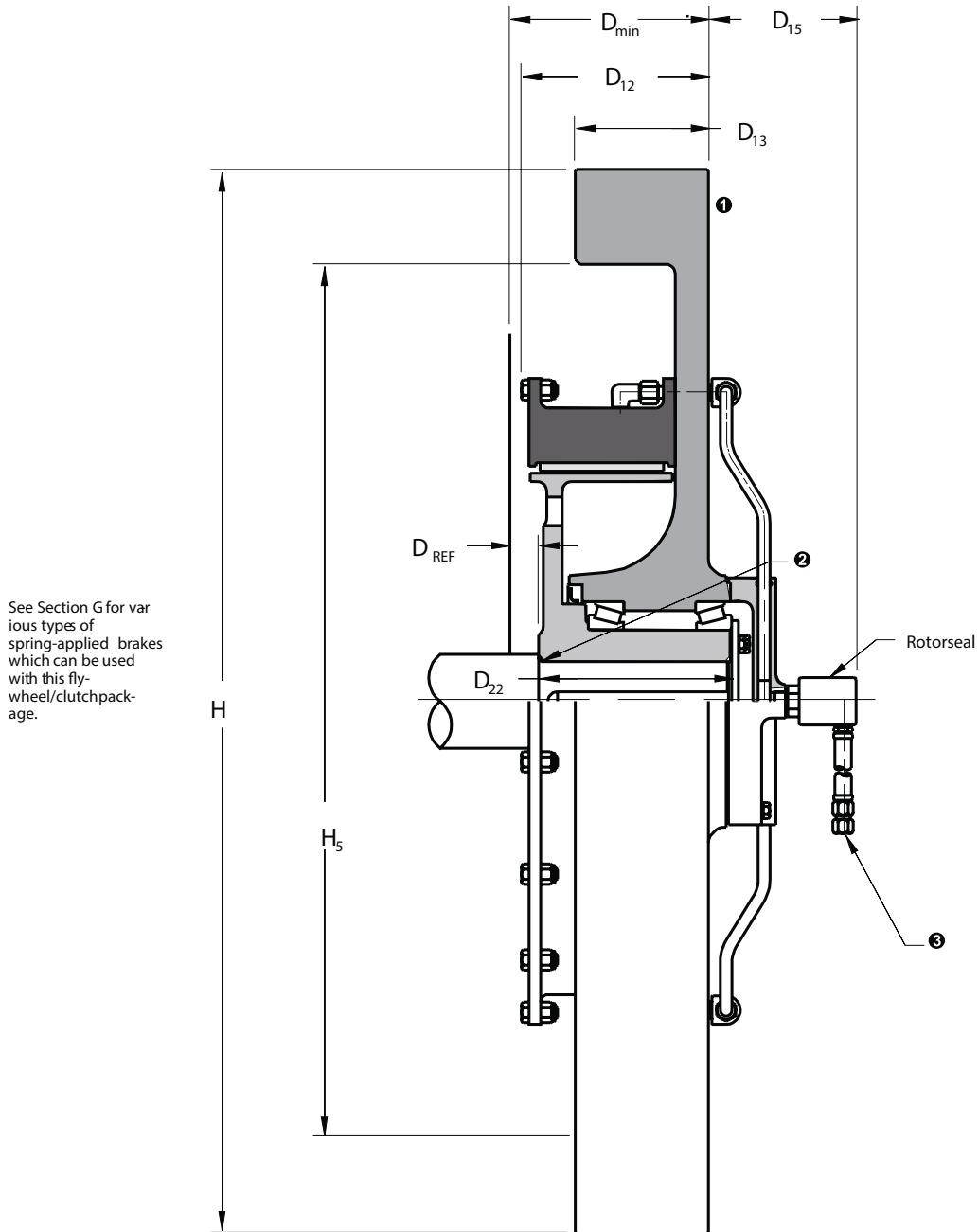

Notes:

- ① Optional belt grooving or gear teeth can be machined in the flywheel rim at additional cost.
- ② Shaft radius 0.25 in (6 mm) for all sizes.

③ American National Pipe Thread

- 1/4-18 for sizes 1127 thru 1136
- 1/2-14 for sizes 1431 thru 2456
- 1-11 1/2 for all other sizes

AMCB AccuStop™

Clutch/Brake Combination

Section F

The Airflex AMCB AccuStop™ clutch/brake combination consists of an air-actuated disc clutch and a spring-applied disc brake. Engineered for small-to-medium tonnage (40 to 400 ton), high speed, high cycle punch presses, the AMCB AccuStop™ unit delivers high torque and low inertia in a compact design.

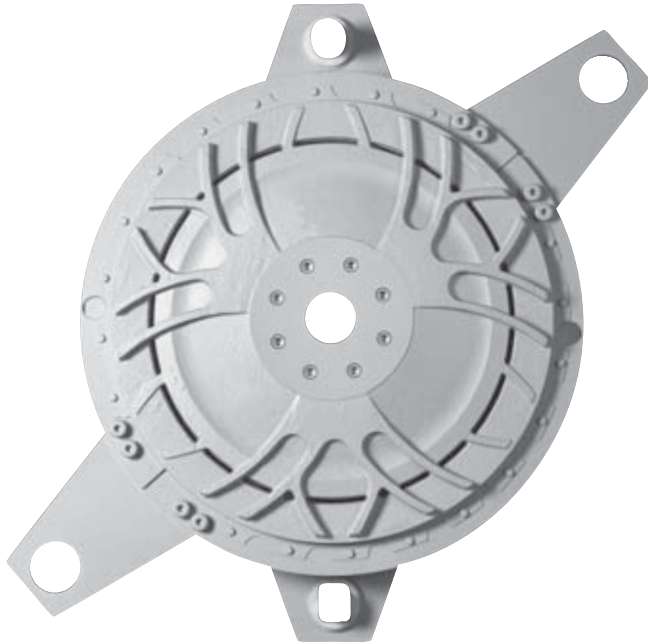

Installation and Operation

The AMCB AccuStop™ clutch/brake unit is adaptable to new or existing flywheel drives. The hub is pressed on and keyed to the drive shaft. The clutch disc is fastened to the flywheel, and the brake disc is reacted to the machine. When the cylinder is pressurized during operation, the piston clamps the clutch disc to the hub, transmitting torque to the shaft. As the cylinder exhausts, the springs move the piston in the opposite direction, clamping the brake disc and stopping the shaft.

A maximum operating pressure of 7.0 bar (100 psi) allows for added torque when needed, and a large torque tube ensures even distribution of torque loads throughout the unit. Efficient air cooling permits a stable coefficient of friction, resulting in reproducible torque control even at maximum wear.

AMCB AccuStop™ units provide clutch torque from 9,830 N·m to 16,140 N·m at 6.0 bar (85 psi) and brake torque of 7,490 N·m.

Standard applications include:

- Automatic punching machines
- Press brakes
- Printing machines
- Shears
- Stamping and forming presses
- Woodworking machines

Features

The AMCB AccuStop™ unit is precision engineered and manufactured from high-performance materials to reduce maintenance time and maintain production. Standard features include:

- Ductile iron cylinder for long cycle life under tough industrial conditions
- Low inertia housing provides less energy per stop
 - maximizes cycle times
 - reduces friction material wear
- Long life friction material results in less downtime, maintenance and replacement cost
- Consistent, stable stopping angle decreases the need for adjustments to the press
- Bolted friction shoes allow for easy replacement without requiring disc removal
- Designed in safety feature provides a signal at the end of friction material life and ensures torque remains to stop the operation
- Engineered, self-lubricating composite bushings for quiet operation
- Danfoss is ISO 9001 certified
- AMCB AccuStop™ design conforms to all relevant portions of ANSI B11.1 standard for metal forming presses

AMCB AccuStop™

Clutch/Brake Combination Component Parts

Section F

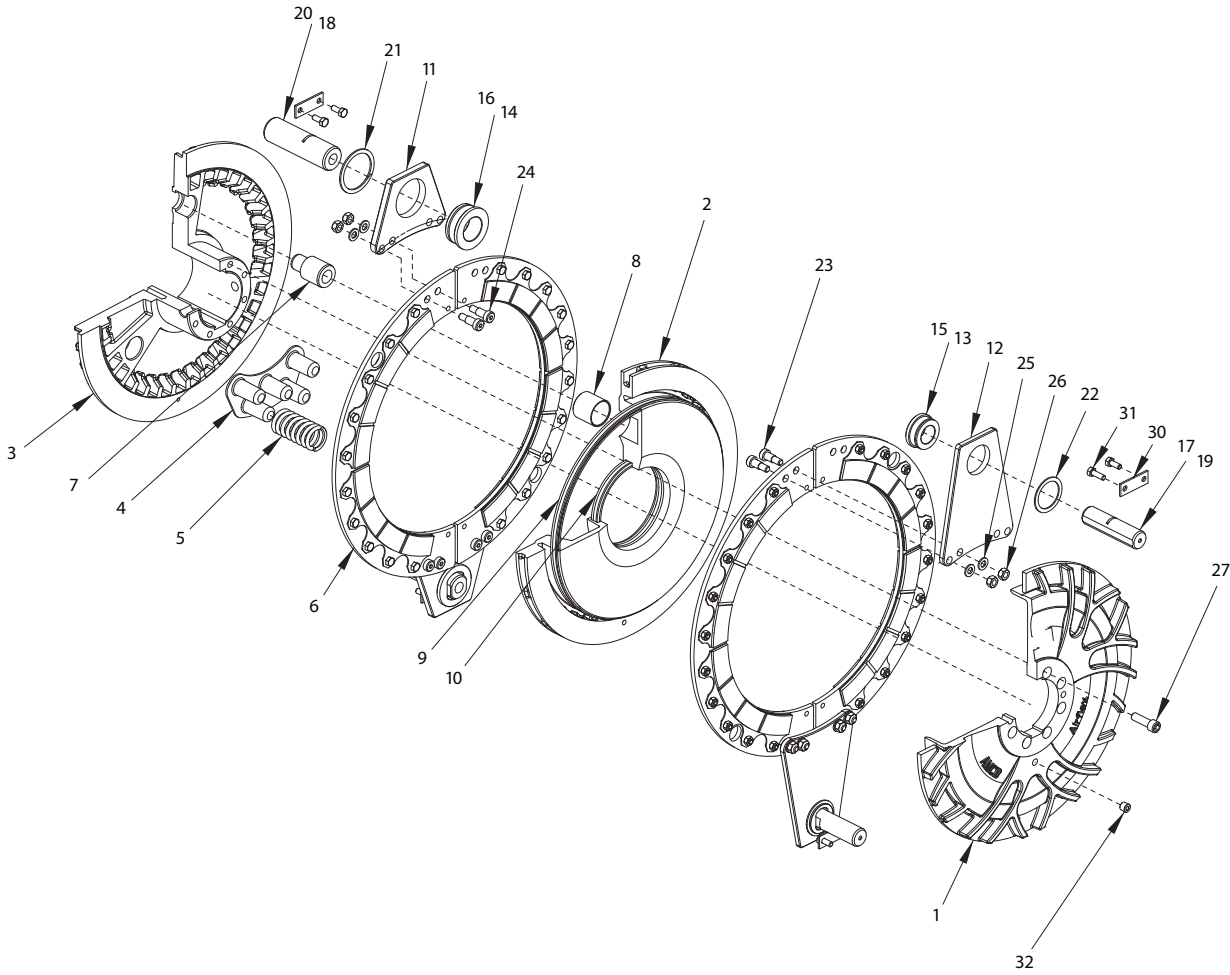

AMCB AccuStop™ Component Parts

Item	Description
1	Cylinder
2	Piston
3	Hub
4	Spring Retainer
5	Compression Spring
6	Friction Disc Assembly
7	Torque Tube
8	Torque Tube Bushing
9	Piston Seal (Outer)
10	Piston Seal (Inner)
11	Short Reaction Arm
12	Long Reaction Arm
13	Long Arm Bushing (Round)
14	Short Arm Bushing (Round)
15	Long Arm Bushing (Rectangular)

Item	Description
16	Short Arm Bushing (Rectangular)
17	Long Arm Reaction Pin (Round)
18	Short Arm Reaction Pin (Round)
19	Long Arm Reaction Pin (Square)
20	Short Arm Reaction Pin (Square)
21	Retaining Ring
22	Retaining Ring
23	Shoulder Bolt
24	Shoulder Bolt
25	Flat Washer
26	Hexagon Nut
27	Socket Head Screw
30	Retaining Plate
31	Hex Head Screw
32	Pipe Plug

AMCB AccuStop™

Clutch/Brake Combination Dimensional Data

Section F

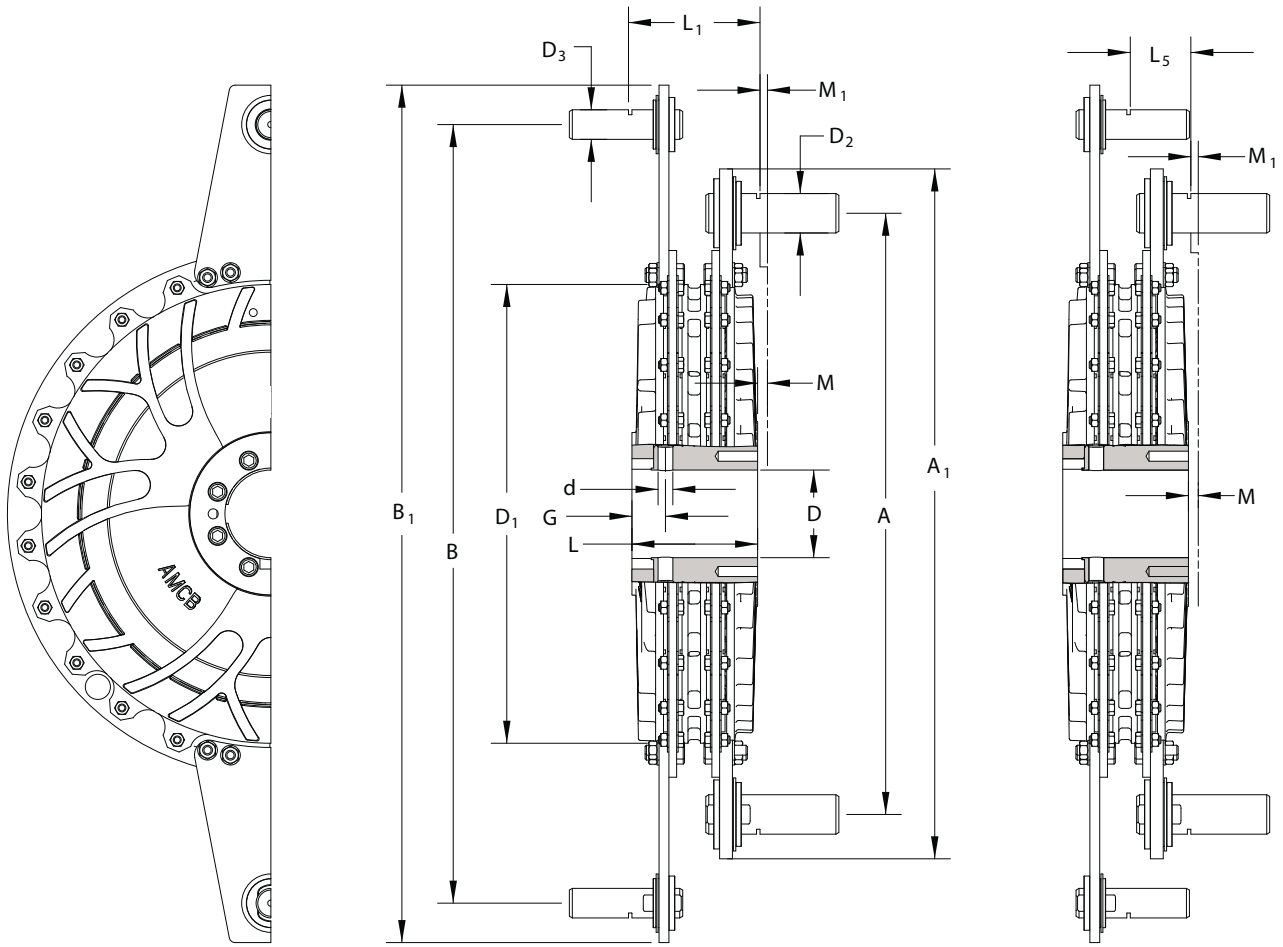

DIMENSIONALS - METRIC UNITS (MM)*																
AMCB AccuStop™ Model	Bore Range (mm)**		A	A ₁	B	B ₁	D ₁	D ₂	D ₃	d	G	L	L ₁	L ₅	M	M ₁
30																
35																
40																
45	72	120	770	880	990	1085	593	45	40	18	42	155	170	102	15	0
50																

This information will be available at a later date.

This information will be available at a later date.

DIMENSIONALS - ENGLISH UNITS (IN)*																
AMCB AccuStop™ Model	Bore Range (in)**		A	A ₁	B	B ₁	D ₁	D ₂	D ₃	d	G	L	L ₁	L ₅	M	M ₁
30																
35																
40																
45	2.835	4.724	30.315	34.646	38.976	42.717	23.346	1.772	1.575	0.709	1.654	6.102	6.693	4.016	0.591	0.000
50																

This information will be available at a later date.

This information will be available at a later date.

* Dimensions shown are for reference only. Consult factory for specific installation information.

** Maximum bores are based on two flat English keys. Consult factory for other arrangements.

AMCB AccuStop™

Clutch/Brake Combination

Section F

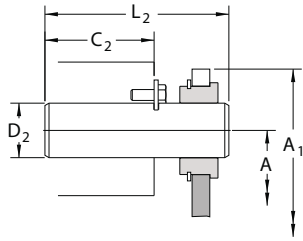

Short Arm Reaction
Pin Mounting Dimensions

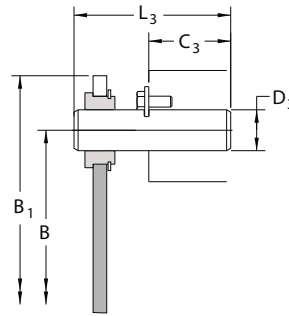

Long Arm Reaction
Pin Mounting Dimensions

ARM MOUNTING DIMENSIONALS - METRIC UNITS (MM)*

AMCB AccuStop™ Model	Short Arm Reaction Pin Mounting Dimension					Long Arm Reaction Pin Mounting Dimension					Screw Size	
	C ₂	D ₂	E ₂	H ₂	L ₂	C ₃	D ₃	E ₃	H ₃	L ₃	d ₄	L ₄
30												
35												
40												
45	90	45	29.5	42	160	80	40	27	42	135	M8	20
50												

This information will be available at a later date.

This information will be available at a later date.

ARM MOUNTING DIMENSIONALS - ENGLISH UNITS (IN)*

AMCB AccuStop™ Model	Short Arm Reaction Pin Mounting Dimension					Long Arm Reaction Pin Mounting Dimension					Screw Size	
	C ₂	D ₂	E ₂	H ₂	L ₂	C ₃	D ₃	E ₃	H ₃	L ₃	d ₄	L ₄
30												
35												
40												
45	3.543	1.772	1.161	1.654	6.299	3.150	1.575	1.063	1.654	5.315	M8	0.787
50												

This information will be available at a later date.

This information will be available at a later date.

* Dimensions shown are for reference only. Consult factory for specific installation information.

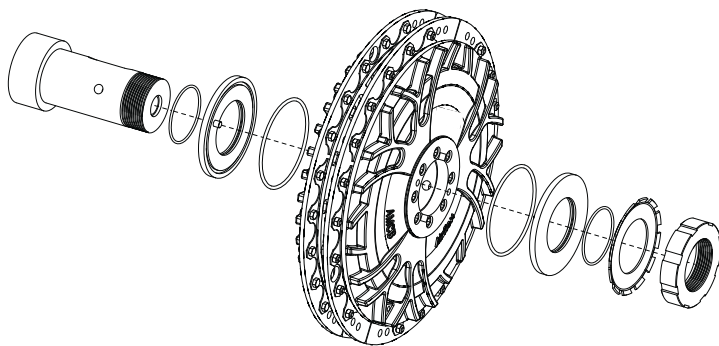

Alternative method of sealing
air supply between the clutch/
brake housing and shaft

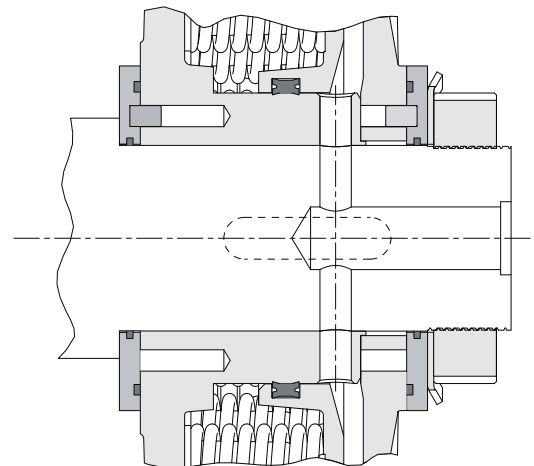

AMCB AccuStop™ Clutch/Brake Combination Technical Data Section F

PERFORMANCE - METRIC UNITS

AMCB AccuStop™ Model	Number of Springs	Dynamic Brake Torque (N-m)	Brake Release Pressure (bar)	Static Clutch Torque (N-m) at Various Pressures (bar)*					
				6.0**	5.5	5.0	4.5	4.0	
30									
35									
40									
45	15	7,490	2.5	9,830	8,790	7,750	6,710	5,660	
	12	5,990	2.0	11,410	10,360	9,320	8,280	7,240	
	9	4,500	1.5	12,980	11,940	10,900	9,850	8,810	
	6	2,990	1.0	14,560	13,510	12,470	11,440	10,400	
	3	1,500	0.5	16,140	15,100	14,060	13,010	11,970	
50									

This information will be available at a later date.

This information will be available at a later date.

PERFORMANCE - ENGLISH UNITS

AMCB AccuStop™ Model	Number of Springs	Dynamic Brake Torque (lb-in)	Brake Release Pressure (psi)	Static Clutch Torque (lb-in) at Various Pressures (psi)*					
				85.0**	80.0	75.0	70.0	65.0	
30									
35									
40									
45	15	66,300	36	87,000	77,800	68,600	59,400	50,100	
	12	53,000	29	101,000	91,700	82,500	73,300	64,100	
	9	39,800	22	114,900	105,700	96,500	87,200	78,000	
	6	26,500	15	128,900	119,600	110,400	101,200	92,000	
	3	13,300	7	142,800	133,600	124,400	115,100	105,900	
50									

This information will be available at a later date.

*Torque Ratings are with new linings. Reduce clutch torque by 10% and brake torque by 15% for fully worn linings.

**Maximum allowable pressure is 7.0 bar / 100 psi.

AMCB AccuStop™

Clutch/Brake Combination

Section F

TECHNICAL DATA - METRIC UNITS					
AMCB AccuStop™ Model	Maximum Speed RPM*	Maximum Air Pressure (Bar)	Brake Release Air Pressure (Bar) 15 Spring Configuration	AMCB AccuStop™ Total Weight (Kg) Includes friction disc/arms	AMCB Housing Inertia (Kg-m²)
30					
35					
40					
45	900	7.0	2.5	160	4.8
50					

This information will be available at a later date.

This information will be available at a later date.

TECHNICAL DATA - ENGLISH UNITS					
AMCB AccuStop™ Model	Maximum Speed RPM*	Maximum Air Pressure (psi)	Brake Release Air Pressure (psi) 15 Spring Configuration	AMCB AccuStop™ Total Weight (lb) Includes friction disc/arms	AMCB Housing Inertia (lb-ft²)
30					
35					
40					
45	900	100	36	352.7	114.4
50					

This information will be available at a later date.

This information will be available at a later date.

*Maximum speed for non-cyclic operation. Maximum speed for single stroke operation is dependent upon clutch and brake thermal requirements.

AMCB AccuStop™ Assembly Numbers

AMCB AccuStop™ Model	BASIC PART NUMBER	BASIC KIT PART NUMBER
30		
35		
40		
45	146512	146512##
50		

This information will be available at a later date.

This information will be available at a later date.

AMCB AccuStop™ Kits

KIT DESCRIPTION	ALPHA DESIGNATION
Lining Kit	KA
Element Seal Kit	KB
Short Arm Kit	KC
Long Arm Kit	KD

Rotorseal Size

AMCB AccuStop™ Model	AIRFLEX ROTORSEAL SIZE
30	
35	
40	
45	1 RH
50	

This information will be available at a later date.

This information will be available at a later date.

Airflex® 21 DCB Clutch/Brake

Section F

Description and Technical Data

Description

The 21DCB combination clutch/brake package was specifically designed for the can making industry to withstand the cyclic impact loads associated with high speed can extruding machinery. A patented quick release air manifold provides fast clutch/brake response; stopping the ram to prevent die damage due to material misfeed.

The unit is ideally suited for high speed continuously running machinery requiring an extremely fast stop.

The package consists of an air-actuated disc clutch and a spring-applied disc brake. The clutch disc is guided axially at its outside diameter by a series of bushings which attach to the driving flywheel. The brake disc is reacted to the machine frame by two reaction arms. The housing hub is pressed on and keyed to the driven shaft.

When the cylinder is pressurized, the piston clamps the clutch disc to the hub, transmitting torque to the shaft. When the cylinder exhausts, springs move the piston in the opposite direction, clamping the brake disc and stopping the shaft. Overlapping cannot occur between clutching and braking.

Technical Data

Torque Rating M_r at 85 psi (5,9 bar)

Clutch static torque: 75000 lb-in (8475 N-m)

Brake dynamic torque: 55000 lb-in (6215 N-m)

Operating Pressure

Maximum allowable pressure p_r : 85 psi (5,9 bar)

Brake releasing pressure p_s : 38 psi (2,6 bar)

Maximum Speed \bullet

1000 rpm

Inertia

Housing : 90 lb-ft² (3,8 kg-m²)

Clutch disc : 18 lb-ft² (0,76 kg-m²)

Weight

Housing and manifold: 290 lb (130 kg)

Each friction disc : 52 lb (24 kg)

Air Cylinder Volume \bullet

With new linings : 55 in³ (0,8 dm³)

With worn linings: 80 in³ (1,3 dm³)

Brake Response to Full Torque

With new linings : 0.035 sec

With worn linings: 0.045 sec

Thermal Capacity

Non-Cyclic: 400000 ft-lb (542400 J)

Cyclic:

100 rpm: 1.5 HP (1,1 kW)

300 rpm: 2.1 HP (1,6 kW)

500 rpm: 2.6 HP (1,9 kW)

700 rpm: 3.1 HP (2,3 kW)

900 rpm: 3.4 HP (2,5 kW)

Notes:

- ① Ratings are for worn in new linings. Decrease ratings 12% for worn linings.
- ② Maximum speed for non-cyclic operation. Maximum speed for single stroke operation is dependent upon thermal requirements. Dynamic balancing required for operating speeds over 750 rpm.
- ③ Absolute volume required per engagement.

Airflex® 21 DCB Clutch/Brake

Section F

Dimensional Data

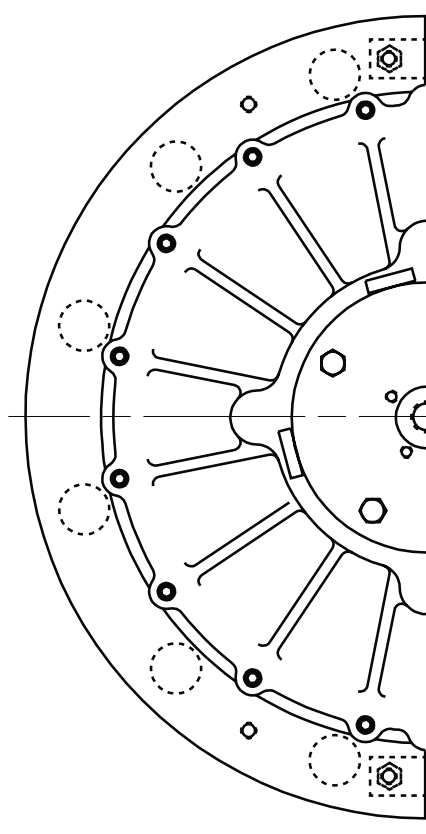
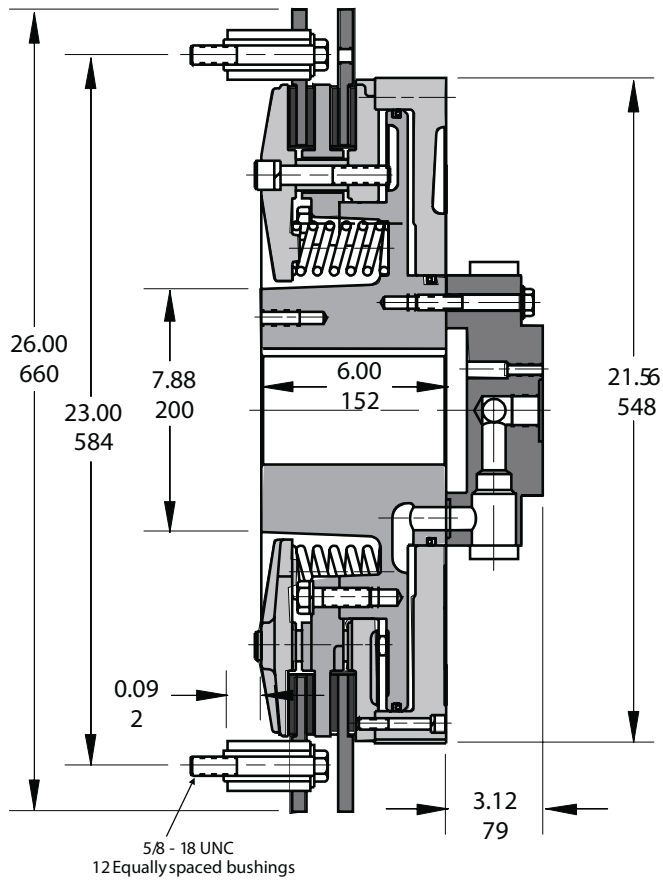

Maximum bore - 5.50 (140mm)

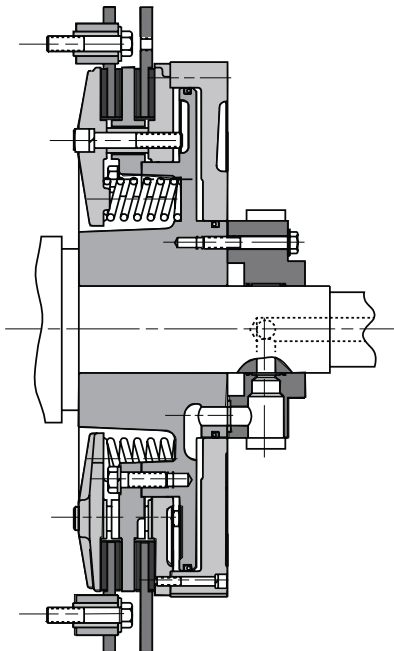

Typical through shaft mounting

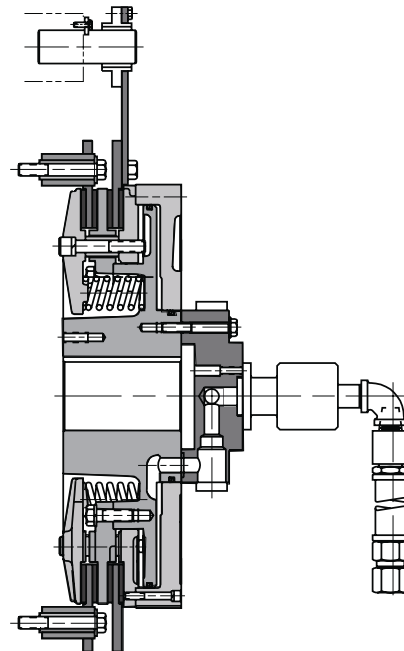

Typical shaft end mounting

Products we offer:

- Cartridge valves
- DCV directional control valves
- Electric converters
- Electric machines
- Electric motors
- Gear motors
- Gear pumps
- Hydraulic integrated circuits (HICs)
- Hydrostatic motors
- Hydrostatic pumps
- Orbital motors
- PLUS+1® controllers
- PLUS+1® displays
- PLUS+1® joysticks and pedals
- PLUS+1® operator interfaces
- PLUS+1® sensors
- PLUS+1® software
- PLUS+1® software services, support and training
- Position controls and sensors
- PVG proportional valves
- Steering components and systems
- Telematics

Danfoss Power Solutions is a global manufacturer and supplier of high-quality hydraulic and electric components. We specialize in providing state-of-the-art technology and solutions that excel in the harsh operating conditions of the mobile off-highway market as well as the marine sector. Building on our extensive applications expertise, we work closely with you to ensure exceptional performance for a broad range of applications. We help you and other customers around the world speed up system development, reduce costs and bring vehicles and vessels to market faster.

Danfoss Power Solutions – your strongest partner in mobile hydraulics and mobile electrification.

Go to www.danfoss.com for further product information.

We offer you expert worldwide support for ensuring the best possible solutions for outstanding performance. And with an extensive network of Global Service Partners, we also provide you with comprehensive global service for all of our components.

Local address:

Hydro-Gear

www.hydro-gear.com

Daikin-Sauer-Danfoss

www.daikin-sauer-danfoss.com

**Danfoss
Power Solutions (US) Company**
2800 East 13th Street
Ames, IA 50010, USA
Phone: +1 515 239 6000

**Danfoss
Power Solutions GmbH & Co. OHG**
Krokamp 35
D-24539 Neumünster, Germany
Phone: +49 4321 871 0

**Danfoss
Power Solutions ApS**
Nordborgvej 81
DK-6430 Nordborg, Denmark
Phone: +45 7488 2222

**Danfoss
Power Solutions Trading
(Shanghai) Co., Ltd.**
Building #22, No. 1000 Jin Hai Rd
Jin Qiao, Pudong New District
Shanghai, China 201206
Phone: +86 21 2080 6201

Danfoss can accept no responsibility for possible errors in catalogues, brochures and other printed material. Danfoss reserves the right to alter its products without notice. This also applies to products already on order provided that such alterations can be made without subsequent changes being necessary in specifications already agreed. All trademarks in this material are property of the respective companies. Danfoss and the Danfoss logotype are trademarks of Danfoss A/S. All rights reserved.