



WCSB tensioner / brake with ORB coolant ports

General information

Warning

Forward this manual to the person responsible for Installation, Operation and Maintenance of the product described herein. Without access to this information, faulty Installation, Operation or Maintenance may result in personal injury or equipment damage.

Note: Part lists in this manual specifically for WCSB assemblies that have cooling ports threaded to accept SAE O-ring boss type fittings. If you are maintaining a WCSB assembly that has cooling ports threaded to accept NPT fittings, refer to manual WSB 11200 for the appropriate part lists or contact the factory for additional information.

Caution

Use Only Genuine Airflex Replacement Parts
Danfoss's Airflex division recommends the use of genuine Airflex replacement parts. The use of non-genuine Airflex replacement parts could result in substandard product performance, and may void your Danfoss warranty. For optimum performance, contact Airflex.

Table of contents

Section	Description	Page No.
	Cutaway Drawing	4
1.0	INTRODUCTION	5
1.1	Description	5
1.2	How It Works	6
2.0	INSTALLATION	6
2.1	Preparation	7
2.2	Mounting	7
2.3	Air S ystem	9
2.4	Coolant S ystem	10
3.0	OPERATION	13
3.1	Conditions of Operation	13
3.2	Pressure and Speed Limits	13
3.3	Wear-in Procedures	14
3.4	Operational Sequence	14
3.5	Periodic Maintenance	15
4.0	MAINTENANCE	16
4.1	Wear Limits	17
4.2	Wear Adjustment	17
4.3	Disassembly P rocedures	21
4.4	Friction Material Replacement	22
4.5	WC Wear Plate Replacement	23
4.6	Cylinder Seal Replacement	26
4.7	Spring R eplacement	27
4.8	Assembly Procedures	28
4.9	Assembly Procedures	29
5.0	ORDERING INFORMATION / TECHNICAL ASSISTANCE	31
5.1	Equipment R eference	31
6.0	PARTS	32
6.1	Basic Assemblies 24WCSB Parts	32
6.2	Basic Assemblies 36WCSB Parts	33
6.3	Basic Assemblies 48WCSB Parts	34
6.4	Sub-A ssemblies (Standard)	35
7.0	KITS	37
7.1	End Plate & P ressure Plate Wear Plate Kits	37
7.2	Reaction Plate Wear Plate Kits	37
7.3	Cylinder Seal Kits (Spring Apply)	37
7.4	Cylinder Seal Kits (Air Apply)	37
7.5	Friction Disc Kits (Standard Water Cooled)	38
7.6	Friction Disc Kits (Standard Air Cooled)	38
7.7	Friction Disc Kits (Corrosion Resistant)	38
7.8	AC Friction Disc Kit (Crossion Resistant)	38
8.0	REVISION PAGE	39

WCSB tensioner / brake with ORB coolant ports

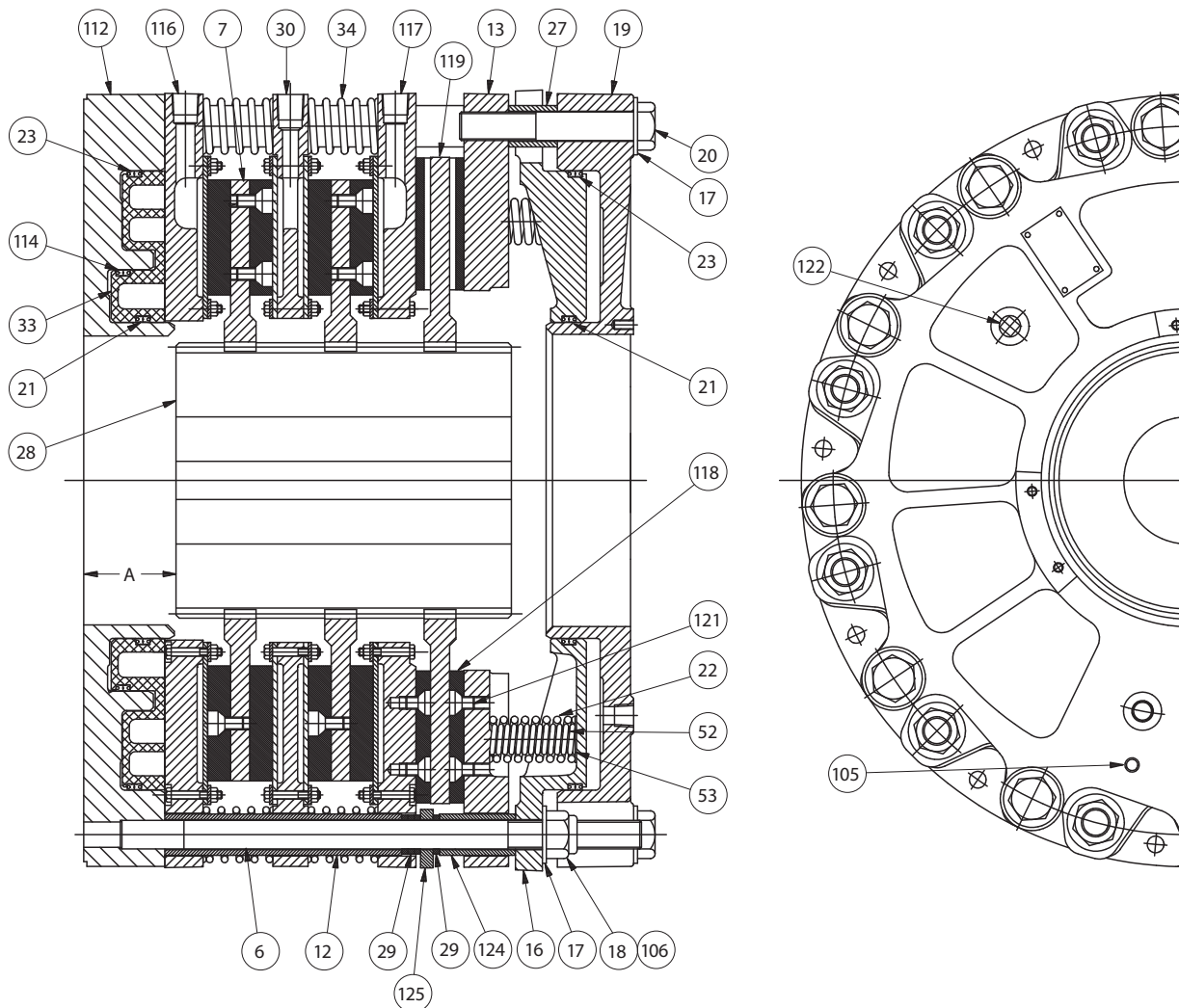

Figure 1

Item Description

Item	Description	Item	Description	Item	Description
6	Stud	23	Seal	112	Mounting Flange / Cylinder
7*	Friction Disc Assembly	27	Spacer Tube	114	Seal
12	Clamp Tube	28	Gear	116*	Pressure Plate S/A
13	Pressure Plate S/A	29	Wear Spacer	117*	End Plate S/A
16	Spring Housing	30*	Reaction Plate S/A	118	Friction Disc
17	Flat Washer	33	Dual Piston	119	Disc
18	Locknut	34	Reaction Spring	121	Flat Head Screw
19	Cylinder	52	Inner Spring	122	Pipe Plug
20	Hex Head Screw	53	Spring Retainer	124	Clamp Tube
21	Seal	105	Pipe Plug	125	Stop Plate
22	Outer Spring	106	Sleeve Nut	127	Pipe Plug

* See Section 6.4 for sub-assembly illustrated part lists and component descriptions.

WCSB tensioner / brake with ORB coolant ports

1.0 INTRODUCTION

Throughout this manual there are a number of HAZARD WARNINGS that must be read and adhered to in order to prevent possible personal injury and/or damage to the equipment. Three signal words "DANGER", "WARNING", and "CAUTION" are used to indicate the severity of the hazard, and are preceded by the safety alert symbol .



Danger

Denotes the most serious injury hazard, and is used when serious injury or death WILL result from misuse or failure to follow specific instructions.



Warning



Used when serious injury or death MAY result from misuse or failure to follow specific instructions.



Caution

Used when injury or product / equipment damage may result from misuse or failure to follow specific instructions.

It is the responsibility and the duty of all personnel involved in the installation, operation and maintenance of the equipment on which this device is used to fully understand the

 Danger,  Warning, and,  Caution procedures by which hazards are to be avoided.

1.1 Description

1.1.1 The Airflex WCSB water-cooled tensioner/ brake assembly is designed for constant tension applications. It is exceptionally well suited for high inertia stop ping and rapid heat dissipation. The WCSB tensioner / brake assembly incorporates both an air applied water-cooled tensioner and an air cooled spring set brake into one relatively compact unit. The water-cooled section is used for high energy, constant slip tensioning, while the spring set brake serves as an emergency stopping or parking brake. The design of the WCSB tensioner / brake assembly permits mid-shaft or end-shaft mounting. The rugged construction ensures long, trouble free service.

1.1.2 WCSB tensioner / brake assemblies are available in various sizes and quantities of friction discs. The model number identifies the number of discs and the nominal disc diameter. For example, 324WCSB indicates three 24" diameter discs. Note that the air-cooled disc is typically larger in diameter by 2" when compared to the water-cooled disc, therefore, the model number will refer to the diameter of the water-cooled discs only. Additional notations are made in describing the model number to indicate the number of water-cooled (WC) disc assemblies and number of air cooled (AC) discs. For example, a 436WCSB (3WC/1AC) would indicate three water-cooled discs and one air cooled disc, whereas a 436WCSB (2WC/2AC) would indicate two water-cooled and two air-cooled discs.

1.1.3 When size, such as 36WCSB, is referred to in this manual, it means that the information given applies to all models using the 36" diameter water-cooled disc assembly; i.e., 236WCSB, 336WCSB, etc.

1.1.4 All WCSB tensioner / brake assemblies referred to in this IOM have SAE O-ring Boss (ORB) ports for the coolant inlets and outlets. These ports utilize a straight thread and appropriately installed fittings have an O-ring for sealing versus the NPT tapered thread used previously and referred to in IOM WSB11200. The ORB ports provide superior sealing properties and reduce the risk of damage to the brake during fitting installation.

1.1.5 The air applied pistons in the WCSB tensioner / brake assemblies are available in either single or dual piston designs. The WCSB tensioner / brake assemblies dual mounting flange/cylinder (112) and dual piston (33) assembly (112) offers precise tensioning control by dividing the piston / cylinder into inner and outer chambers that are isolated by intermediate seals (114). Also, for light tensioning loads, the inner chamber is used, not the outer chamber. See Figure 1. This provides the ability to improve fine modulation of clamping pressure on the tensioner discs and improved control over our standard single chamber design. For very light tensioning loads, the outer piston can be used solely, with no pressure applied to the inner piston. For the largest tensioning loads, both pistons can be used together. If it is desirable to operate the WCSB tensioner / brake assembly at maximum tensioning load and not utilize the precise tensioning feature, the WCSB tensioner / brake assembly can be ordered without the intermediate piston seal (114).

WCSB tensioner / brake with ORB coolant ports

1.1.6 WCSB tensioner / brake assemblies can be used with either closed loop or open loop water systems.

1.1.7 This manual includes metric equivalents usually shown in () following the U.S. measurement system value. Be sure to use the correct value.

1.2 How It Works

1.2.1 Referring to Figure 1, the gear (28) is mounted on the shaft which is to be stopped and the tensioner assembly is attached to the machine frame or a reaction bracket.

Air pressure is first applied through the ports in the mounting flange/cylinder (112) causing the piston (33) to apply force to the pressure plate assembly (116). As air pressure is applied through the ports in the cylinder (19) on the spring set section of the unit, the cylinder and pressure plate (13), which are attached to each other with screws (20), flat washers (17) and spacer tubes (27), move away from the mounting flange (112), which is connected to the machine frame or reaction bracket. The pressure plate compresses the springs (22) and (53) against the stationary spring housing (16). As the pressure plate moves, the end plate subassembly (117) also moves away from the mounting flange/cylinder until it rests against the stop plates (125) which are axially fixed. The pressure plate (13) then continues to move away from the end plate subassembly and the clamp force is removed from the disc (119) that rides on the gear.

As the end plate subassembly (117) moves towards the stop plates, the piston (33) and friction disc subassemblies (7) also move by means of the air pressure initially applied. Relieving the air pressure within the mounting flange/cylinder reduces the clamp force applied to the friction discs, allowing the shaft to be free to rotate. Modulation of the air pressure then controls applied torque of WCSB tensioner / brake assembly .

As air pressure is exhausted from both the mounting flange/cylinder (112) and the cylinder (19), the springs force the pressure plate (13) toward the mounting flange, clamping the disc (119) between the pressure plate and the end plate subassembly (117). As the piston (33) retracts, the endplate subassembly continues to move towards the mounting flange / cylinder, pressing against the friction disc assemblies (7), reaction plate (30) and pressure plate subassembly (116). As the pressure plate (116) comes to rest against the mounting flange, the spring force clamps all discs between adjacent surfaces, applying stopping torque to the shaft.

High heat dissipation within the tensioner section in the WCSB tensioner / brake assembly is accomplished by passing water through a special cavity behind copper alloy wear plates (3).

2.0 INSTALLATION



Warning

Only qualified maintenance personnel should install, adjust or repair these units. Faulty workmanship will result in unreasonable exposure to hazardous conditions or personal injury.



Caution

Read these instructions thoroughly and review until you fully understand the installation sequence before proceeding with the work described in this section. Failure to follow these instructions will result in unreasonable exposure to hazardous conditions or personal injury.



Caution

Do not paint the clamp tubes (12), (124), wear spacers (29), or the springs (34), as this may hinder the engagement or disengagement of the WCSB tensioner / brake assembly.

WCSB tensioner / brake with ORB coolant ports

2.1 Preparation

2.1.1 Refer to the appropriate assembly drawing (available upon request) for appropriate envelope dimensions, mounting register diameters, mounting bolt circles and positions, and stud support bracket recommendations for each specific WCSB tensioner / brake assembly.

2.1.2 The WCSB tensioner / brake assembly's reaction member should have a machined register to allow for mounting and alignment control of the WCSB tensioner / brake assembly and allow for full support of the face of the mounting flange/cylinder (112).

2.1.3 For proper operation and service life, the WCSB tensioner / brake assembly reaction member must be aligned to the shaft within the limits shown in Table 1.



Caution

Proper alignment is necessary to ensure that the friction discs track properly. Improper alignment will result in excessive wear to the friction material and mating surfaces, plus the gear and splined bore of the friction disc assemblies. See Figure 2.

Table 1
Alignment Requirements

Size	Concentricity (Parallel, TIR) of Shaft and Tensioner Inches (mm) Shaft*	Perpendicularity (Angular, TIR) of Mounting Flange to Inches (mm)
24WCSB	0.010 (0,25)	0.012 (0,30)
36WCSB	0.010 (0,25)	0.019 (0,48)
48WCSB	0.010 (0,25)	0.025 (0,64)

*Perpendicularity measured near the outside diameter of the mounting flange

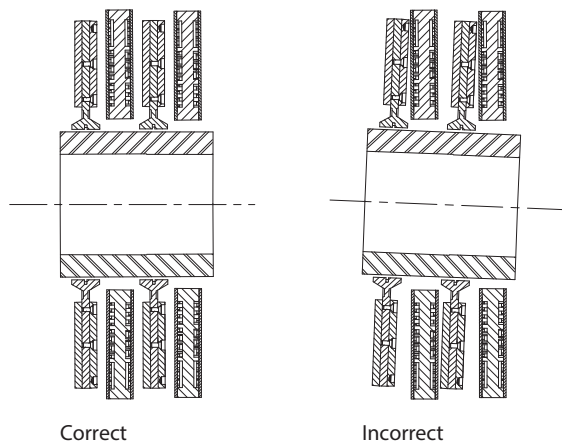

Figure 2

2.1.4 Refer to the appropriate assembly drawing for the setup dimension between the tensioner mounting surface and the end of the gear (dimension "A" on Figure 1). Gears should be positioned to ensure that when the tensioner is mounted the disc splines will not overhang the end of the gear when components are in both new and worn conditions. The gear is typically bored and keyed for a resulting Class FN2S interference fit for inch shafting and ISO System S7h6 for metric shafting. Contact Airflex Application Engineering for specific recommendations.

2.2 Mounting

2.2.1 The WCSB tensioner / brake assembly must be mounted to a clean, rigid surface with hardened flat washers and screws of the grade, quantity, and size as listed in Table 2. Mounting to a properly aligned, rigid surface that fully supports the face of the mounting flange minimizes any deflection during operation and helps to ensure that the friction discs will track properly on the copper wear plates.

Note: Before installing the gear (28) onto the shaft, slide it into the brake assembly to align the splines in the friction disc assemblies. Air pressure must be applied to the brake cylinder (19) to release the friction disc assemblies for alignment. Once the gear passes through all friction disc assemblies, exhaust the air to clamp them into position and remove the gear.



Danger

Use only the proper number and grade fasteners shown in Table 2. Use of commercial grade (Grade 2) fasteners where Grade 8 fasteners are specified may result in failure of the fasteners and a sudden and drastic reduction in brake torque.



Caution

Water inlets and outlets must be located as close as possible to the 6 o'clock and 12 o'clock positions, respectively. This will prevent air pockets in the water cavity, which would allow the WCSB tensioner / brake assembly to overheat.

2.2.2 Ensure that the shaft is free of nicks or burrs and the key fits properly in the shaft and gear.

2.2.3 Apply a light coat of anti-seizing compound to the shaft and key. Tap the key into the shaft keyway.

WCSB tensioner / brake with ORB coolant ports

2.2.4 Heat the gear uniformly to 250 °F (121 °C) to expand the bore and ease assembly. Press the gear onto the shaft, making sure that the dimension between the gear and the tensioner mounting surface ("A") is maintained. See Figure 1. Allow the gear to cool.

2.2.5 Apply a thin coat of MOLUB-ALLOY 936 SF Heavy or equivalent grease to the splines of the gear.

⚠ Caution
Excessive lubricant may contaminate friction material, resulting in erratic response or loss of torque.

⚠ Caution
The use of anti-seize or bearing greases on the gear splines may result in premature gear and disc spline wear.

2.2.6 Pre-fill the grease channel in the friction disc splines (if applicable) with MOLUB-ALLOY 936 SF Heavy or equivalent grease, as shown on Figure 3.

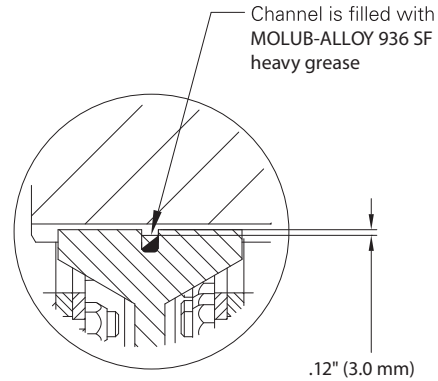

Figure 3

2.2.7 Rig the WCSB tensioner / brake assembly into position and slide it over the gear. Avoid placing lifting straps or cables directly on the release springs (34).

Table 2
Fastener Description and Assembly Torque - ft.-lb. (Nm)

Item	Description	Specification	24WCSB	36WCSB	48WCSB
4	Wear Plate Screw	Size	5/16-18 NC Gr. 8	3/8-16-NC2 Gr. 8	3/8-16-NC2 Gr. 8
5	Locknut	Quantity	90	108	120
		Torque, Dry	21 (28)	40 (54)	40 (54)
18	Locknut	Size	1 1/8-7 NC Gr. 8	1 3/8-6 NC Gr. 8	1 3/8-6 NC Gr. 8
106		Quantity	12	16	16
		Torque, Lubed	500 (677)	750 (1016)	750 (1016)
20	Hex Head Screw	Size	1 1/8-7 NC Gr. 8	1 3/8-6 NC Gr. 8	1 3/8-6 NC Gr. 8
		Quantity	12	16	16
		Torque, Lubed	500 (677)	750 (1016)	750 (1016)
57	WC Friction Disc Screw	Size	1/2-13 NC Class 3	1/2-13 NC Class 3	1/2-13 NC Class 3
		Quantity	36	144	224
		Torque, Loctite # 262	15 (20)	15 (20)	15 (20)
121	Dry Friction Disc Screw	Size	1/2-13 NC Class 3	1/2-13 NC Class 3	1/2-13 NC Class 3
		Quantity	48	72	90
		Torque, Loctite # 262	20 (27)	20 (27)	20 (27)
Customer Supplied	Mounting Screw	Size	5/8-11NC-2 Gr. 8	1-8 NC Gr. 8	1 3/8-6NC Gr. 5
		Quantity	10	14	14
		Torque, Lubed	150 (203)	660 (895)	1100 (1490)
Customer Supplied	SAE Coolant Fittings	Size	SAE-12	SAE-20	SAE-20
		Quantity*	4	4	4
		Torque, O-Ring Lube	68-78 (92-105)	146-171 (198-231)	146-171 (198-231)

*Note: Increase the quantity of SAE coolant fittings by 4 for each Reaction Plate S/A (30) in the WCBD tensioner/brake assembly.

WCSB tensioner / brake with ORB coolant ports

2.2.8 While supporting the WCSB tensioner / brake assembly, connect an air supply to the cylinder (19) and apply adequate pressure to release the WCSB tensioner / brake assembly. Attach the mounting flange (2) to the mounting surface using the appropriate fasteners. Tighten the fasteners to the specified torque value. See Table 2. Exhaust the air from the cylinder after tightening the fasteners.

 **Caution**
Maximum allowable air pressure in the cylinder (19) is 150 psig (10.2 bar).

2.2.9 Some WCSB tensioner / brake assembly (typically 3 and 4 disc assemblies) require an additional support bracket to minimize torsional deflection during operation. Refer to the appropriate assembly drawing for bracket recommendations. The bracket, when required, will fit over the sleeve nuts (106) located on the studs (6) closest to the 6 o'clock position. Secure the bracket onto the sleeve nuts with flat washers (17) and locknuts (18). Tighten the locknuts to the value listed in Table 2. Shim the base of the support bracket as required. Install and tighten fasteners as required to secure the bracket into position.

 **Warning**
Ensure that the support bracket does not interfere with or bind on the cylinder (19). Interferences could prevent the WCSB tensioner / brake assembly from properly engaging or releasing.

2.2.10 WCSB tensioner / brake assembly tensioners should be covered to protect the unit from dirt, rain, overspray, and other sources of external contamination. In extreme environments the use of a sealed enclosure with internal strip heater is recommended to prevent moisture from collecting on the unit.

2.3 Air System

 **Warning**
Operation of the WCSB tensioner / brake assembly at pressures exceeding those specified in Section 3.2 may result in damage to components.

 **Caution**
Minimum releasing pressure for the spring set brake should be observed. Operation at pressures below minimum will result in WCSB tensioner / brake assembly drag, excessive heat and wear, and damage to brake components.

 **Caution**
When applying operating pressure to only one of two ports on units with dual pressure pistons (33), the second piston pressure port must be open and

vented to atmosphere. Porting should be filtered to avoid contamination of the piston / cylinder during single piston actuation.

2.3.1 Maximum allowable pressure is 150 psig (10.2 bar) in the spring set brake cylinder (19), and 150 psig (10.2 bar) in the air applied mounting flange/cylinder (112). See Section 3.2 for other limitations.

2.3.2 Use only clean, filtered air (a 50 micron filter or better is recommended) which is free of excess moisture. Exhaust porting in dual pressure piston/cylinders should also be filtered to avoid contamination when open to atmosphere during single port actuation.

2.3.3 Air inlet sizes are shown in Table 3. Air inlets for the spring set brake are on the face of the cylinder (19). Air inlets for the air applied tensioner (radially located in the mounting flange) should be located at or near the 6 o'clock position to facilitate purging of moisture that may accumulate in the air system.

Table 3
Actuation Port Sizes

Size	Cylinder (3 ports)	Mounting Flange (Small Piston)	Mounting Flange (Large Piston)
24WCSB	1/2"-14 NPT	1/4"-18 NPT	1/2"-14 NPT
36WCSB	3/4"-14 NPT	3/8"-18 NPT	3/4"-14 NPT
48WCSB	1"-11.5 NPT	1/2"-14 NPT	1"-11.5 NPT

2.3.4 All pipes should be free of metal chips, cutting compound and any other foreign matter. Pipe ends should be reamed after cutting to eliminate possible restrictions. For optimum air system response, a minimum number of bends and elbows should be used.

2.3.5 The final connection to the brake inlet ports on the cylinder (19) must be made with flexible hose. If using only one inlet, connect the hose to the lowest position.

2.3.6 The WCSB tensioner / brake assembly does not require lubricated air; however associated control valves may. Consult the valve manufacturer for appropriate recommendations.

WCSB tensioner / brake with ORB coolant ports

2.4 Coolant System

2.4.1 An ORB port can be identified by the machined spot face and a chamfer (for sealing of the O-ring). See Figure 4. See Table 2 for the torque to values and the ORB fitting size associated with each WCSB tensioner / brake assembly.

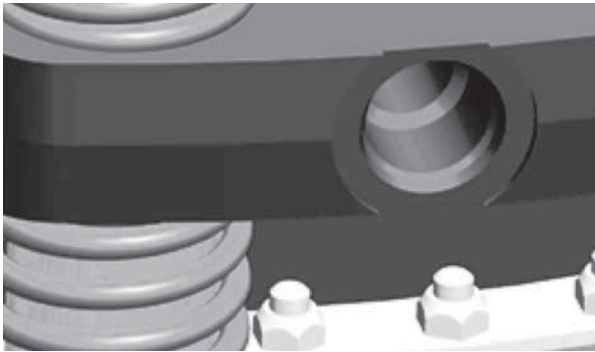

ORB Port

Figure 4



Caution

Make sure that the water inlets and outlets are positioned as close as possible to the 6 o'clock and 12 o'clock positions, respectively. This will help to minimize the formation of air pockets in the water cavity during operation, which could contribute to overheating of the WCSB tensioner / brake assembly.



Caution

Installation of NPT or other incompatible threaded piping or fittings into ORB ports will damage the ports, resulting in leakage or other failure.

2.4.2 Installation of straight SAE fittings.

2.4.2.1 Inspect the SAE fittings for damage and contamination.

2.4.2.2 Apply Molykote[®] 55 O- ring lubricant to the O- ring on the SAE fitting.

2.4.2.3 Turn the SAE fitting into ORB port until finger tight, then apply the respective assembly torque. Refer to Table 2.

2.4.3 Installation of adjustable SAE fittings.

2.4.3.1 Inspect the SAE fittings for damage and contamination.

2.4.3.2 Apply Molykote[®] 55 O- ring lubricant to the O- ring on the SAE fitting.

2.4.3.3 Ensure the O-ring and back up washer on the SAE fitting are in the proper position on non-threaded section of the SAE fitting nearest to locknut.

2.4.3.4 Tighten the SAE fitting by hand into the threads of the ORB port until the back-up washer contacts the face of the ORB port.

2.4.3.5 To position the SAE fitting, unscrew the SAE fitting up to one full turn then hold the SAE fitting in desired position and tighten locknut so that the back-up washer contacts face of ORB port and forces the O-ring on the SAE fitting within the boss cavity. Tighten to the torque listed in Table 2.



Caution

When installing SAE fittings male NPT fittings are very similar in size to SAE threads and will engage in the female SAE threaded ports. If this is done the WCSB tensioner/brake assembly may be damaged! Only use SAE fittings in the coolant ports of the WCSB tensioner/brake assemblies.

2.4.4 Maximum allowable coolant pressure is 40 psig (3.1 Bar) for size 36WCSB and 48WCSB units and 45 psig for the 24WCSB. The use of an accumulator or pressure relief valve may be desirable to reduce the effect of pressure spikes in the coolant system during operation.



Warning

Maximum allowable water pressure is dependent upon WCSB tensioner / brake assembly model. Applied pressure or surges exceeding maximum allowable may result in damage to the WCSB tensioner / brake assembly.

2.4.5 The coolant supply and discharge hose, pipe and fitting sizes, along with minimum flow rates for the WCSB tensioner / brake assembly's rated horsepower, are listed in Table 4.

2.4.6 Coolant supply connections to the tensioner should provide a parallel flow through each section of the tensioner. Series flow is not recommended, as it can lead to overheating of the WCSB tensioner/brake assembly.

2.4.7 Inlet and outlet coolant manifolds must be provided. Manifolds should be constructed to allow for even flow through all ports.

WCSB tensioner / brake with ORB coolant ports

Table 4
Coolant Supply Data

Model	Thermal Rating HP (kW) ₁	Water Inlet and Outlet Pipe Size (Minimum piping I.D.)	Min Flow Rate GPM (dm ³ /min) 100% Water ₂	Min Flow Rate GPM (dm ³ /min) 70% Water, 30% Ethylene Glycol by vol. ₃	Min Flow Rate GPM (dm ³ /min) 60% Water, 40% Ethylene Glycol by vol. ₄	Min Flow Rate GPM (dm ³ /min) 50% Water, 50% Ethylene Glycol by vol. ₅
124	270 (201)	SAE-12 (3/4")	27 (102)	32 (121)	35 (132)	40 (151)
224	540 (402)	SAE-12 (3/4")	54 (204)	64 (242)	70 (265)	80 (303)
324	810 (603)	SAE-12 (3/4")	81 (305)	96 (361)	105 (395)	120 (451)
424	1080 (805)	SAE-12 (3/4")	108 (406)	128 (481)	140 (526)	160 (602)
136	650 (485)	SAE-20 (1")	65 (246)	76 (288)	84 (318)	98 (371)
236	1300 (969)	SAE-20 (1")	130 (489)	152 (572)	168 (632)	196 (737)
336	1950 (1454)	SAE-20 (1")	195 (738)	228 (863)	253 (958)	294 (1113)
436	2600 (1937)	SAE-20 (1")	260 (978)	304 (1143)	336 (1263)	392 (1474)
148	1300 (969)	SAE-20 (1-1/4")	130 (489)	152 (572)	168 (632)	196 (737)
248	2600 (1937)	SAE-20 (1-1/4")	260 (978)	304 (1143)	336 (1263)	392 (1474)
348	3900 (2906)	SAE-20 (1-1/4")	390 (1467)	456 (1715)	504 (1895)	588 (2211)
448	5200 (3874)	SAE-20 (1-1/4")	520 (1956)	608 (2286)	672 (2526)	784 (2948)

1. Thermal rating based on a 70°F (21°C) water inlet temperature and a 50°F (28°C) temperature rise between inlet and outlet.

2. 10HP/GPM, (1.97kw/(dm³/min))

3. 8.55HP/GPM, (1.68kw/(dm³/min))

4. 7.74HP/GPM, (1.53kw/(dm³/min))

5. 6.63HP/GPM, (1.31kw/(dm³/min))

Note: Minimum Flow Rates listed above to achieve thermal rating. Lower flow rates are acceptable provided satisfy peak thermal requirement.

2.4.8 Use flexible connecting hose to each WCSB tensioner / brake assembly coolant section to allow axial travel of the pressure plate, reaction plate, and end plate during WCSB tensioner / brake assembly operation. Hose lengths running between the manifold and the inlet or outlet ports should be equal in length, if possible. Reductions in the recommended line diameter should be avoided to prevent excessive line pressures.

2.4.9 Avoid the use of sharp bends and elbows that will restrict water flow. Loops and bends in the lines may create air pockets, which substantially reduce the flow of coolant and can contribute to overheating.

2.4.10 Coolant and coolant supply lines should be free of foreign material (a 500 micron water filter is recommended). In the event that contaminated water is used as a coolant (not generally recommended), use of a multistage filter/strainer may be desirable to avoid the need for frequent cleaning of fine mesh filters.

2.4.11 Figure 5 illustrates a typical closed loop liquid to liquid coolant system. The heat exchanger and temperature control would be replaced with a radiator, fan and motor in a liquid to air system.

2.4.12 The coolant supply temperature at the inlet should be 100°F (38 °C) or lower. The coolant outlet temperature should not exceed the values given in Table 5. However, in no event should there be more than a 50°F (28 °C) temperature rise between inlet and outlet. See Table 5 for maximum allowable outlet coolant temperature with various water / ethylene glycol mixtures and other cooling media.

Table 5
Maximum Inlet & Outlet Coolant Temperature

Water/Ethylene Glycol Mixture % by volume	Maximum Allowable Coolant Inlet Temperature °F (°C)*	Maximum Allowable Coolant Outlet Temperature °F (°C)	Maximum Allowable Coolant Temperature Rise °F (°C)
100/0	100 (38)	150 (66)	50 (28)
70/30	115 (46)	165 (74)	50 (28)
60/40	115 (46)	165 (74)	50 (28)
50/50	120 (49)	170 (77)	50 (28)

* Provided that temperature rise is no greater than 50°F (28C)

WCSB tensioner / brake with ORB coolant ports

2.4.13 Open Loop Systems

For efficient operation of the WCSB tensioner/brake assembly, an adequate supply of filtered fresh water is required. (See section 2.4.1 - 2.4.2). Excessive water hardness promotes the formation of scale deposits, which, in time, will affect the service life of the WCSB tensioner / brake assembly. Water of high acidity or high in corrosive salts may cause electrolytic corrosion between the dissimilar metals used in the water cavities. Water treatment should be considered if the properties of the water exceed the following: Equivalent calcium carbonate content hardness): Maximum 100 p.p.m. pH value: 7.0 to 9.0.



Caution

Open loop systems should be thoroughly flushed with clean fresh water after operation to reduce the corrosive effects of contaminants on internal components.

2.4.14 Closed Loop Systems

For efficient operation of the WCSB tensioner/brake assembly in a closed loop system, ethylene glycol coolant conforming to SAE Standard J1034 should be used. For preparation of the proper concentration of a water / ethylene glycol mixture, use make-up water which is low in corrosive ions such as chlorides and sulfates. Recommended pH value of the water / ethylene glycol mixture: 7.5. to 10.5.

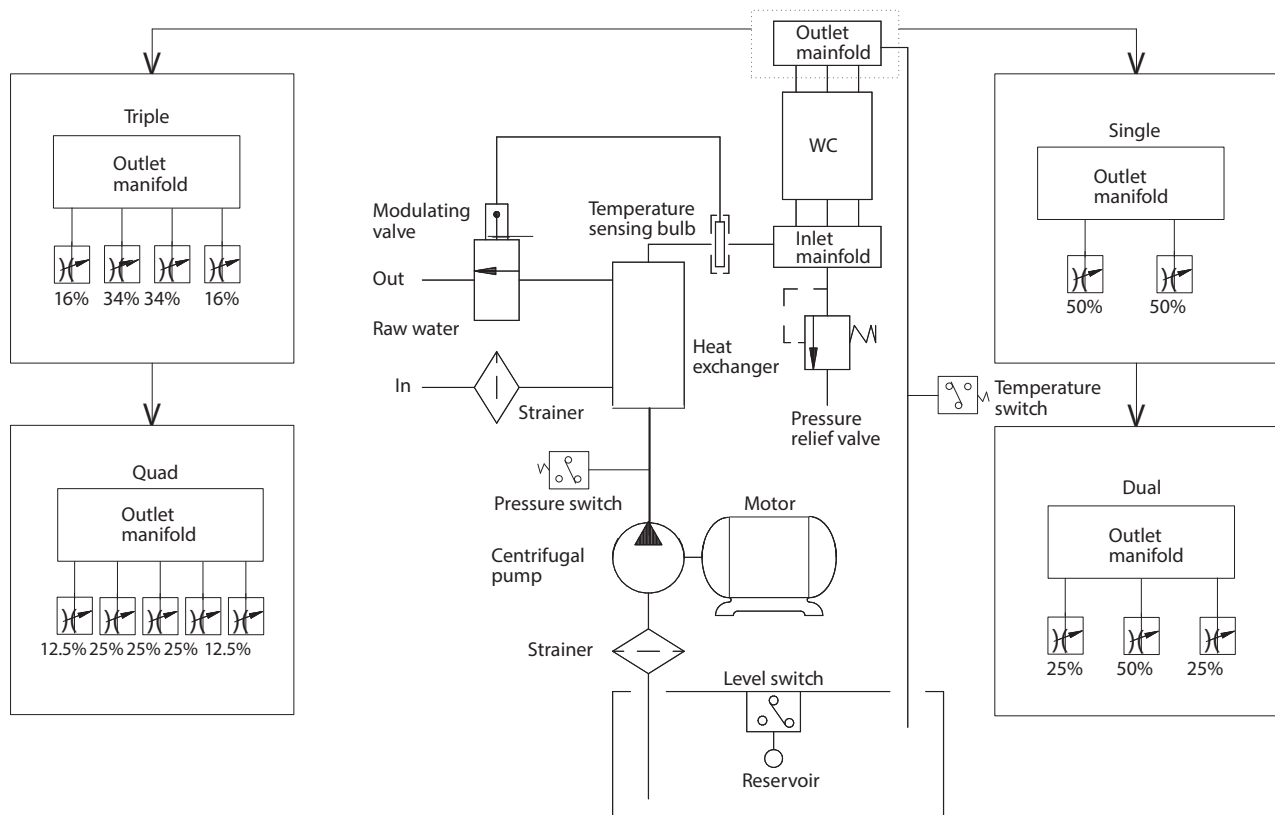

Figure 5

WCSB tensioner / brake with ORB coolant ports

3.0 OPERATION

3.1 Conditions of Operation

The following Hazard Warnings are to be followed for proper WCSB functioning:



Warning

Friction material must be worn in to achieve product torque rating. Verify proper operation before putting the product into service. See Section 3.3 for additional burnishing procedures.



Warning

Protective means must be used to prevent oil, grease, dirt or coolant from coming into contact with the surfaces of the friction discs (8), (118), disc (119) or the wear plates (3). Oil or grease on these parts will significantly reduce the torque capacity of the WCSB tensioner / brake assembly. Dirt or coolant will produce erratic torque. Do not risk personal injury or damage to the equipment!



Warning

Maximum free-wheeling speed must not exceed the speeds listed in Table 6. Exposure to speeds in excess of these values may cause the friction discs (8) to burst and result in extensive damage to the tensioner and / or cause personal injury.



Caution

For proper cooling of the WCSB tensioner / brake assembly, it is required that the coolant inlet is located as close as possible to the 6 o'clock position and the outlet is located near the 12 o'clock position. This will help to assure that all coolant cavities are water-filled to help avoid over-heating.



Caution

For operation in subfreezing temperatures, ethylene glycol antifreeze must be added to the water. The antifreeze content of the mixture is critical and should not exceed 50% by volume. Excessive amounts of antifreeze will reduce cooling capacity and can cause coolant leakage due to overheating. Refer to Table 5.



Caution

Maximum ambient temperature is 110 °F (43 °C). Minimum ambient temperature for closed loop systems using ethylene glycol antifreeze is 0 °F (-18°C). For open loop systems using water, the minimum temperature is 45 °F (7 °C).

Table 6

Maximum Disc Speeds

Size	Maximum Slip Speed RPM	Maximum Free Wheeling Speed RPM
24WCSB	715	1200
36WCSB	475	700
48WCSB	360	600

3.2 Pressure and Speed Limits

3.2.1 Maximum allowable coolant pressure is 40 psig (2.8 bar) for the 36WCSB and 48WCSB tensioner / brake assemblies and 45psig (3.1 bar) for the 24WCSB tensioner / brake assembly. The use of an accumulator or pressure relief valve may be desirable to reduce the effect of pressure spikes in the coolant system during operation.



Warning

Maximum allowable water pressure is dependent upon WCSB tensioner / brake assembly model. Applied pressure or surges exceeding maximum allowable may result in damage to the WCSB tensioner / brake assembly.

3.2.2 Maximum slip speeds and free-wheeling disc speeds are shown in Table 6.



Caution

Excessive slip speeds will result in rapid friction material wear. For good life, the values in Table 9 should not be exceeded.

3.2.3 Maximum allowable pressure is 150 psig (10.2 bar) in the spring set brake cylinder (19). Refer to the assembly drawing (available on request) for minimum pressure required for full release of the spring set brake. Release pressure is dependent upon the quantity of springs (22) (52) used in the specific brake.

3.2.4 Maximum allowable pressure within the air applied tensioner mounting flange/cylinder (112) is 150 psig (10.2 bar). Maximum operating pressure is specified on the assembly drawing mentioned in section before 3.2.3.

WCSB tensioner / brake with ORB coolant ports

3.3 Wear-in Procedures

3.3.1 In order to improve initial operation and brake torque, it is suggested that the non-asbestos friction material used in WCSB tensioner / brake assembly be worn-in prior to normal operation to improve contact of the mating friction surfaces.



Caution

Machine operation should be monitored closely until the friction material wears in.

3.3.2 The shaft on which the brake discs are mounted should be free to rotate to allow for run-in. On drawworks applications, disconnect the wire rope from the drawworks drum to allow operation as described in the following paragraphs.

3.3.3 Ensure that the coolant system is operating prior to dynamic operation of the WCSB tensioner / brake assembly. Verify that coolant temperature, pressure and flow values are within required settings or limits during operation.



Caution

Dynamic operation of the WCSB tensioner / brake assembly including while in the fully released condition is not recommended without proper coolant flow in the WCSB tensioner/brake assembly. Heat generated during operation could result in damage to WCSB tensioner / brake assembly components.

3.3.4 Release the brake by applying full release pressure through the ports in the cylinder (19) to allow the brake to freely rotate. Apply no pressure to the tensioner pressure ports in the mounting flange/cylinder (112).

3.3.5 Run the motor to achieve a brake disc speed listed in Table 6. Exhaust the air pressure in the brake rapidly to 90 psig (6.1 Bar). Slip the brake for the time specified in Table 7, but **DO NOT ALLOW THE BRAKE TO SLIP FOR MORE THAN THE TIME SPECIFIED.**



Caution

Slipping the WCSB tensioner / brake assembly at increased time intervals, speeds or pressures other than specified will result in damage to WCSB tensioner / brake assembly components.

3.3.6 After the WCSB tensioner / brake assembly has engaged / slipped for upto the maximum slip time specified in Table 7, quickly apply full air pressure to completely release the WCSB tensioner / brake assembly. Smoke rising from the brake should be expected. Freewheel the brake discs at the speed listed in Table 7, allowing the brake disc (119) to cool to a temperature below 120 °F (48 °C). The use of fans or clean, dry compressed air can be used to accelerate the cooling process.



Caution

Use proper safety precautions when using forced ventilation.

Table 7
Wear-in Parameters

Size	Operating Speed (RPM)	SlipT ime (S econds)	Wear-in Cycles Req uired
24WCSB	120	16	30
36WCSB	60	20	30
48WCSB	30	20	30

3.3.7 Monitor the brake disc (119) temperature after slipping and cooling. Do not allow the brake disc temperature to exceed 180 °F (82.2 °C).

3.3.8 Repeat steps 3.3.4 thru 3.3.7 for the number of cycles shown in Table 7 to allow for adequate wear-in of the air-cooled brake. Allow the brake disc to completely cool to ambient temperature prior to testing the torque capacity of the brake or returning it to service.

3.4 Operational Sequence

3.4.1 Ensure that the coolant system is operating prior to dynamic operation of the WCSB tensioner / brake assembly. Verify that coolant temperature, pressure and flow values are within required settings or limits during operation.



Caution

Dynamic operation of the WCSB tensioner / brake assembly including while in the fully released condition is not recommended without proper coolant flow in the tensioner. Heat generated during operation could result in damage to brake components.

WCSB tensioner / brake with ORB coolant ports

3.4.2 Air pressure is first applied through the ports in the mounting flange/cylinder (112) to apply force to the piston (33) in the WCSB tensioner / brake assembly. Adequate pressure should be applied to support the load the WCSB tensioner / brake assembly is controlling. Air pressure is then applied through the ports in the cylinder (19) on the spring set section of the WCSB tensioner / brake assembly, until it is fully released.



Caution
Observe all pressure and speed limits while operating the WCSB tensioner / brake assembly. See Section 3.2.

3.4.3 After release of the spring set brake, slowly relieve the air pressure within the mounting flange/ cylinder (112) to reduce the clamp force applied to the friction disc assemblies (7), allowing the shaft to rotate. Modulation of the air pressure will vary the applied torque of the WCSB tensioner / brake assembly. Modulation control is dependent upon the specific pneumatic control system used. Refer to the manufacturers information for operation of control valves or feedback systems.

3.4.4 WCSB tensioner / brake assembly with dual pressure pistons (33) provide a more finite range of control. Each chamber within the dual pressure piston can be pressurized independently or simultaneously.



Caution
When applying or exhausting operating pressure to only one of two ports on units with dual pressure pistons (33), the second piston pressure port must be open/vented to atmosphere. Open ports should be filtered to avoid contamination of the piston and cylinder during piston operation.

3.4.5 Exhausting air pressure from the cylinder (19) of the spring set brake allows it to engage. Air pressure within the mounting flange/cylinder (112) can be exhausted simultaneously with that in the cylinder (19). For more rapid brake response, exhaust the air pressure in the mounting flange/cylinder (112) after engaging the spring set brake.

Note: The spring set brake is intended for parking or emergency braking only.



Warning
Dynamic braking with the air cooled, spring set brake is not recommended except for emergency stopping situations or during initial wear-in. High heat generated during dynamic braking can result in damage or failure of the WCSB tensioner / brake assembly's components.



Caution
Rapid engagement of a fully released WCSB tensioner / brake assembly could result in pressure spikes within the coolant cavities and subsequent leakage.

3.5 Periodic Maintenance

3.5.1 As the friction material wears, adjustment of the brake may be required to keep pistons and cylinders within the proper stroke range. See the MAINTENANCE section for wear adjustment procedures and component wear limits.

3.5.2 Periodically check for external air leakage in the area of the piston seals (21) (23), and internal leakage across the dual pressure piston seals (114). For replacement, refer to procedures in Section 4.6, Maintenance.

3.5.3 Moisture that may accumulate in the brake cylinder can be purged on size all WCSB tensioner / brake assemblies. With air pressure exhausted from the cylinder, remove the pipe plug (105) at the 6 o'clock position on the cylinder, and apply low air pressure to assist in expelling any excess moisture. After draining the cylinder, reinstall the pipe plug, applying a pipe thread sealant on the threads prior to installation.



Caution
Applied air pressure greater than 10 psig (.69 Bar) should not be used when draining the cylinder. Use adequate shielding to avoid contact with direct spray from moisture being purged from the cylinder.

3.5.4 Periodically observe the discs while the brake or tensioner is fully released. Dragging discs may be caused by wear or contamination of the gear or disc splines, disc imbalance, warped discs, or misalignment. Correct as required.

3.5.5 Pneumatic and electrical control interlocks should be periodically checked for proper settings and operation.

WCSB tensioner / brake with ORB coolant ports

3.5.6 If leakage or blockage of any water-cooled chamber is suspected, a static or dynamic test may be performed as follows:

3.5.6.1 Static Pressure Test

(a) Release the spring set brake by applying the proper air pressure,

 **Warning**
Ensure that the machinery will remain in a safe position prior to releasing the WCSB tensioner / brake assembly.

(b) Bleed all air from within the coolant cavity. Air bleeding must be accomplished by running coolant through the cavity with the tensioner secured in its proper operating position.

Note: Avoid contaminating the friction material with coolant or water.

 **Warning**
Contamination of the friction material could result in erratic or loss of torque.

(c) After the air has been removed, install a pipe plug(s) in the outlet(s) and apply maximum allowable coolant pressure measured at the inlet to the water cavity. Maximum allowable is 40 psig (2.7 bar) for size 36WCBS and 48WCSB tensioner / brake assemblies, and 45 psig (3.0 bar) for the 24WCSB tensioner / brake assembly. Maintain this pressure for 30 minutes. Check for leakage at O.D. and I.D. sealing areas.

 **Caution**
Be sure to apply and retain air pressure to the cylinder (19) of the WCSB tensioner / brake assembly to release the spring pressure on the WCSB tensioner / brake assembly during static coolant pressure testing. Engagement of the brake during testing could develop surge pressures exceeding the maximum allowable within the coolant cavities resulting in possible damage to the seals.

3.5.6.2 Dynamic Flow Test

(a) Dynamic flow testing of the WCSB tensioner/brake assembly should be conducted at the required flow rate for the rated HP dissipation and coolant quality, as given in Table 4. Inlet pressure for the appropriate WCSB tensioner / brake assembly model is not to be exceeded.

(b) There should be no restrictions on the outlet side of the WCSB tensioner / brake assembly to cause any backpressure to the unit. Coolant inlet and outlet sizes are listed in Table 4. Full size hoses and piping should be used. Check for low flow and/or leakage at the O.D. and I.D. seal areas.

4.0 MAINTENANCE

 **Warning**
Before doing any maintenance work on the WCSB tensioner / brake assembly, make sure that the machinery will remain in a safe position. Failure to do so could result in serious injury or possibly death.

 **Warning**
Only qualified maintenance personnel should install, adjust or repair these WCSB tensioner / brake assembly. Faulty workmanship will result in unreasonable exposure to hazardous conditions or personal injury.

 **Caution**
Read these instructions thoroughly and review until you fully understand the parts replacement steps before proceeding with the work described in this section. Failure to follow these instructions can result in unreasonable exposure to hazardous conditions or personal injury.

WCSB tensioner / brake with ORB coolant ports

4.1 Wear Limits



Warning

Periodically examine the WCSB tensioner / brake assembly for wear of friction material, discs and wear plates. Failure to perform this examination will result in excessive wear, a significant reduction in torque, and may result in personal injury and / or damage to the machinery.

4.1.1 Wear limits for the WCSB tensioner / brake assembly's components are shown in Table 8. If any wear limit has been reached or exceeded, that component must be repaired or replaced.

4.2 Wear Adjustment

Wear adjustment is periodically required as the friction material and mating surfaces wear. Wear adjustment reduces the running clearances between these surfaces to help maintain the holding force of the brake (for the spring applied feature), and to maintain the responsiveness of the brake by limiting the travel of components. Mechanical limits within the brake design require that the brake be adjusted when the adjustment points listed in Table 8 have been reached.



Warning

Failure to perform adjustments when required may result in loss of adequate brake torque and potential injury to personnel or damage to equipment. Be certain to inspect the brake periodically to evaluate for wear, and adjust as necessary.

4.2.1 WCSB tensioner / brake assembly Inspection and Evaluation

To determine when WCSB tensioner / brake assembly adjustment is required, the WCSB tensioner / brake assembly should be evaluated as follows:

4.2.1.1 Visually inspect for friction material wear.

The friction material is fully worn when the wear has reached the bottom of the wear groove or notch as shown in Figure 6.

Note: Friction blocks for the air cooled brake in 48WCSB tensioner / brake assemblies have a step on the outer edge of the friction material rather than a wear groove. The material is fully worn when wear has reached the step on the outer edge of the friction material. See Figure 6a.

Note: If fully worn replace the material and evaluate the condition of the mating wear surface.

Note: If the wear limits of any of the friction discs or blocks have not been reached, determine if brake adjustment is required by proceeding to the next steps.

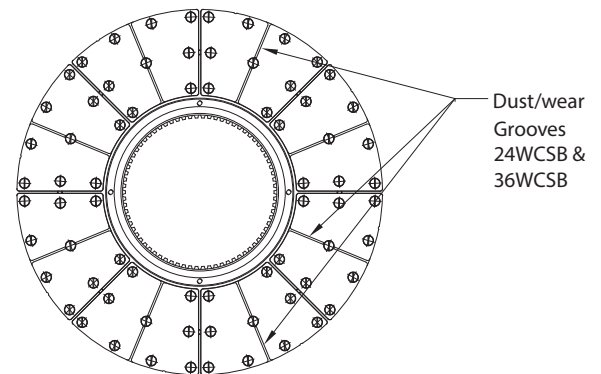

Figure 6

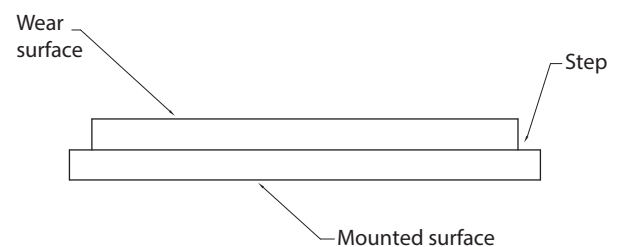

Figure 6A
48WCSB

WCSB tensioner / brake with ORB coolant ports

Table 8
Wear Limits for WCSB Components - inches (mm)

Item	Component	Description	Wear Limit/Remarks		Original Sizes/Remarks	
3	Wear Plate	Friction Wear Signature	Brake Size: 24WCSB 36WCSB 48WCSB	Maximum Wear: 0.045 (1,14) 0.050 (1,27) 0.060 (1,52)	Wear will be in the form of even wear or circular grooves in the copper surface.	
8	Friction Disc	Friction Material	Fully worn at the bottom of the dust groove or wear notch on the 48WCSB.		Brakes have adjustment provision. See Section 4.2	
9 28 119	Friction Disc Core & Gear, and Disc	Gear Backlash	Maximum total backlash is 0.060 (1.5).		If step is worn in gear, gear must be replaced.	
12	Clamp Tube	Reaction Area	Maximum wear is 0.015 (0.38).		Wear will be in the form of notch or step on the side of tube.	
31 14 117a	Reaction Plate Pressure Plate End Plate	Reaction Holes	Wear will be in the form of elongation of the holes. Maximum wear is 0.031 (0.80).		Original Reaction Hole and Bushing Sizes: Brake Size: Bore Size: 24WCSB 1.668 (42,88) 36WCSB 2.065 (52,45) 48WCSB 2.375 (60,33)	
19	Cylinder	Seal Area	Maximum wear is 0.005 (0.13).		Wear will be in form of grooves where the seals contact the cylinder wall.	
22	Spring	Spring Free Height	Springs must be replaced in complete sets. WCSB Brake Size:	Minimum Free Height:	WCSB Brake Size:	Original Free Height:
			24	4.90 (124,46)	24	5.18 (131,57)
			36	6.37 (161,8)	36	6.65 (168,91)
			48	8.75 (222,25)	48	9.00 (228,6)
34	Spring	Spring Free Height	WCSB Brake Size:	Minimum Free Height:	WCSB Brake Size:	Original Free Height:
			24	3.88 (98,55)	24	4.00 (101,6)
			36	3.88 (98,55)	36	4.00 (101,6)
			48	4.85 (123,19)	48	5.00 (127,6)
52	Spring	Spring Free Height	WCSB Brake Size:	Minimum Free Height:	WCSB Brake Size:	Original Free Height:
			24	4.95 (125,73)	24	4.00 (101,6)
			36	6.5 (165,1)	36	4.00 (101,6)
119	Friction Disc	Friction Material	Maximum wear is 0.045 (1,12) per surface. (0.09 (2,24)Total)		WCSB Brake Size:	Original Thickness:
					24	1.00 (25,4)
					36	1.25 (31,7)
					48	1.25 (31,7)

4.2.1.2 Measure for WCSB tensioner / brake assembly wear:

(a) Ensure that the load that the WCSB tensioner / brake assembly supports will be properly secured from possibility of movement when no pressure is being applied to the brake(s) being inspected.

(b) Exhaust all air pressure from the pressure chambers on both ends of the WCSB tensioner / brake assembly being evaluated. Pressurized areas are located in the Cylinder (19) and Mounting Flange (112).

If more than one WCSB tensioner / brake assembly is used in the driveline, exhaust all air pressure from those brakes also.

Note: Follow the recommendations of the control system manufacturer to ensure that no air pressure is trapped in the brake or control system, and that the control system has been safely isolated from the WCSB tensioner / brake assembly while performing inspections.

(c) Verify that the air pressure has been fully exhausted from these chambers by checking any in-line gauges (they should read zero pressure), and also by inspecting specific gaps between components as noted below. Refer to Figures 6 and 6A for the corresponding gap locations.

Pressure in the cylinder (19) has been exhausted if the measured gap Z is greater than zero, and there is no clearance between each side of the disc (119) and the corresponding friction material.

Pressure in the mounting flange (112) has been exhausted if gap Z-2, located between the mounting flange and the pressure plate (116) is closed and gap W is greater than zero.

WCSB tensioner / brake with ORB coolant ports

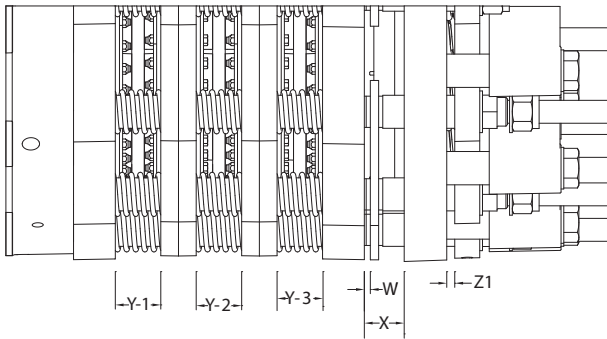

Figure 7

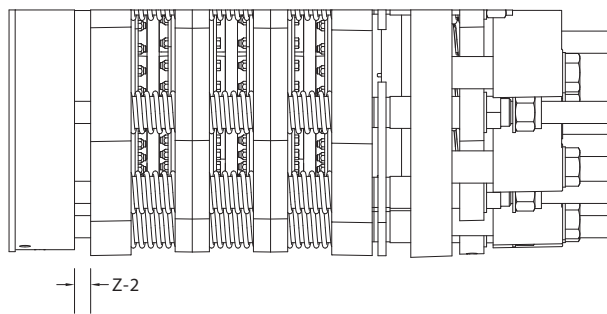

Figure 7A

- (d) Measure gaps between the components at positions W, X, Y-1, and if applicable, Y-2, and Y-3. See Figures 6, and 6a for the location of those gap positions.

For reference:

The W-gap is the measurement between the end plate (117) and the stop plates (125) and is used to determine when adjustment of the water-cooled section of the WCSB tensioner / brake assembly is required. This gap will increase as the WCSB tensioner / brake assembly wears.

The X-gap is the measurement between the end plate (117) and the pressure plate sub-assembly (13) and is used to determine when adjustment of the air-cooled section of the WCSB tensioner / brake assembly is required. This gap will decrease as the WCSB tensioner / brake assembly wears.

The Y gaps are measurements between the various wear plate sub-assemblies and are used to help evaluate the wear of the water-cooled friction discs and wear plates. These gaps will decrease as the WCSB tensioner / brake assembly wears. The wear limit for each of the Y gaps is the same for Y-1, Y-2 or Y-3.

Y-1 is the measurement between the mounting flange (116) and the reaction plate (30).

Y-2 is the measurement between the reaction plate (30) and the adjacent reaction plate. The Y-2 gap is found only on WCSB tensioner / brake assembly that have three or more 'water-cooled' discs.

Y-3 is the measurement between the reaction plate (30) and the end plate (117).

- e) Record the W, X, Y-1, Y-2, and Y-3 values measured for each of the gaps, and compare them against the values listed in Table 9.
- f) If the value measured for any Y gap (Y-1, Y-2, Y3) is equal to or less than the Y min value, the WCSB tensioner / brake assembly should be removed from service and repaired with new wear components.
- g) If the value measured for all Y gaps (Y-1, Y-2 or Y-3) is greater than the Y min value, proceed to evaluate the measurement for gap W as follows:
- h) If the measurement for gap W is equal to or greater than the Wadjust value shown on Table 8, wear adjustment is required. Adjust the WCSB tensioner / brake assembly per the procedures listed in section 4.2.2. If it is found that no wear spacers (29) exist between the clamp tube (12) and stop plate (125) before adjustment is attempted, all wear adjustments have been previously performed in the water-cooled section of the WCSB tensioner / brake assembly and brake overhaul is required.
- i) If the gap measured for gap X is equal to or less than the Xadjust value, wear adjustment is required. Adjust the WCSB tensioner / brake assembly per the procedures listed in section 4.2.2. If it is found that no wear spacers (29) exist between the clamp tube (124) and stop plate (125), all wear adjustments have been previously performed in the air-cooled section of the brake and replacement of the friction discs (118) and disc (119) may be required. Remove the WCSB tensioner / brake assembly from service and evaluate the condition of those components, using Table 9 as a reference.

WCSB tensioner / brake with ORB coolant ports

Table 9
Wear Measurements W, X, Y, & Z Gaps – Inches (mm)

Model	W - New	W - Adjust	X - New	X - Adjust	X - Min	Y - Min	Z-1 - New	Z - 2
224	.070/.110 (1,78/2,79)	.340 (8,64)	2.142 (54,40)	1.892 (48,06)	1.642 (41,71)	2.37 (60,20)	.140/.220 (3,56/5,59)	
324	.140/.220 (3,56/5,59)	.430 (10,92)	2.142 (54,40)	1.892 (48,06)	1.642 (41,71)	2.19 (55,63)	.210/.330 (5,38/8,38)	
424	.210/.330 (5,33/8,38)	.520 (13,20)	2.142 (54,40)	1.892 (48,06)	1.642 (41,71)	* 2.19 (55,63)	.280/.440 (7,11/11,18)	
236	.100/.140 (2,54/3,56)	.370 (9,40)	2.392 (60,75)	2.142 (54,40)	1.892 (48,06)	2.25 (57,15)	.200/.280 (5,08/7,11)	
336	.200/.280 (5,08/7,11)	.490 (12,45)	2.392 (60,75)	2.142 (54,40)	1.892 (48,06)	2.25 (57,15)	.300/.420 (7,62/10,67)	
436	.300/.420 (7,62/10,67)	.610 (15,50)	2.392 (60,75)	2.142 (54,40)	1.892 (48,06)	2.25 (57,15)	.400/.560 (10,16/14,22)	
248	.136/.176 (3,45/4,47)	.406 (10,31)	2.392 (60,75)	2.142 (54,40)	1.892 (48,06)	2.86 (72,62)	.272/.352 (6,91/8,94)	
348	.272/.352 (6,91/8,94)	.562 (14,27)	2.392 (60,75)	2.142 (54,40)	1.892 (48,06)	2.86 (72,62)	.408/.528 (10,36/13,41)	
448	.408/.528 (10,36/13,41)	.718 (18,24)	2.392 (60,75)	2.142 (54,40)	1.892 (48,06)	2.86 (72,62)	.544/.704 (13,82/17,88)	
If recorded value is	Equal or greater than W adjust		Equal or less than X adjust		Greater than Y min		Greater than Zero	Equal to Zero
Then	Adjust		Adjust		Inspect friction disc condition Note: If measured value is less than Y min, rebuild the brake.		Check Z - 2	OK to for wear

* Y-2 Min gap is 2.03" (51,56)

4.2.2 Adjustment Procedure

Wear adjustment can be conducted without full disassembly of the WCSB tensioner / brake assembly.



Warning
Before performing any maintenance work on the WCSB tensioner / brake assembly, make sure that the machinery will remain in a safe position. Failure to do so could result in serious injury or possibly death.

4.2.2.1 Wear spacers should be removed in complete sets only (one from each stud location). Mark the spacers to be removed to avoid confusion during removal.

Note: For wear adjustment of the spring set brake (gap X), remove spacers closest to the short clamp tubes (124). For adjustment of the water-cooled tensioner (gap W), remove spacers closest to the long clamp tubes (12).



Warning
Removal of spacers in quantities other than complete sets (layers) will result in severe damage to WCSB tensioner / brake assembly's components during re-assembly, and could cause the brake to not function properly.

4.2.2.2 If so equipped, remove the support bracket from the cylinder (19) end of the WCSB tensioner / brake assembly.

4.2.2.3 Loosen the locknuts (18) and sleeve nuts (106) if applicable ONE TURN AT A TIME and in an alternating (cross wise) pattern. Loosen each locknut only two or three turns.



Caution
The locknuts (18) must not be loosened unless the hex head screws (20) are in place.

4.2.2.4 Wear spacers are slotted to allow for in-place removal. Using a narrow chisel wedged between the stud and the spacer, as shown in Figure 8, wedge/pry the wear spacer until it fractures and is clear to be removed from the stud. Repeat for the remaining spacers in the set that is to be removed.



Warning
Be sure to collect all wear spacers when removed. Spacers lodging in between WCSB tensioner / brake assembly components could prevent the WCSB tensioner / brake assembly from properly engaging or releasing.

WCSB tensioner / brake with ORB coolant ports

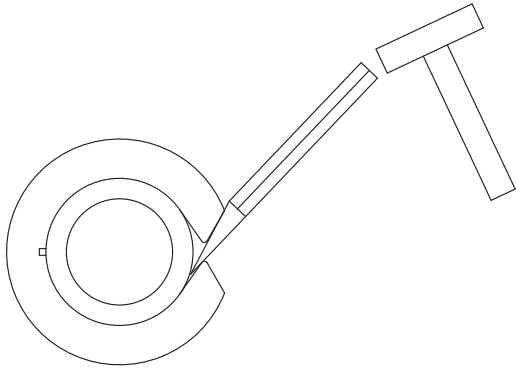

Figure 8

- 4.2.2.5 While supporting the weight of the cylinder / spring housing/pressure plate assembly, tighten the locknuts (18) and sleeve nuts (106) if applicable ONE TURN AT A TIME and in a crosswise pattern, until the spring housing is seated tightly against the clamp tubes. Torque the locknuts and sleeve nuts to the appropriate value. See Table 2.



Caution

The locknuts (18) and sleeve nuts (106) must be tightened gradually and evenly to prevent damage to the WCSB tensioner / brake assembly components.

- 4.2.2.6 Reinstall the support bracket if required. Secure the bracket onto the sleeve nuts using flat washers (17) and locknuts (18). Tighten the locknuts to the value listed in Table 2. Shim the base of the support bracket as required. Install and tighten fasteners as required to secure the bracket into position.



Warning

Ensure that the support bracket does not interfere with or bind on the cylinder (19). Interferences could prevent the brake from properly engaging or releasing.

- 4.2.2.7 Restore any piping or covers removed prior to operating the WCSB tensioner / brake assembly.

4.3 Disassembly Procedures



Warning

Ensure that the machinery is and will remain in a safe position prior to loosening fasteners or removing the WCSB tensioner / brake assembly.

- 4.3.1 Disconnect the air supply lines and water lines from the WCSB tensioner / brake assembly.

- 4.3.2 Remove the fasteners that secure the brake and support bracket to the mounting structure.

- 4.3.3 Using soft slings, rig the WCSB tensioner / brake assembly and slide the WCSB tensioner / brake assembly off of the gear. Avoid placing slings or straps directly on the release springs (34).

- 4.3.4 Transport the WCSB tensioner / brake assembly to a clean working area and position the unit on a flat surface with the mounting flange (112) facing down.

- 4.3.5 If the gear (28) requires replacement, remove it from the shaft with a portable jack, using the threaded holes in the end of the gear for puller holes. Heating may be required to ease removal. Replace the gear and install per Section 2.2.

- 4.3.6 Match-mark the mounting flange (112), pressure plate (116), reaction plates (30), end plate (117), pressure plate (13), spring housing (16), and cylinder (19) to one another prior to disassembly to adequately show the proper orientation of components to one another.

- 4.3.7 Loosen the locknuts (18) or sleeve nuts (106) ONE TURN AT A TIME and in sequence until the release spring force is relieved.



Caution

The locknuts (18) must not be loosened unless the screws (20) are in place retaining brake spring tension.

- 4.3.8 Lift the cylinder, spring housing, and pressure plate off of the studs as an assembly. Set the assembly aside on a clean, level area, making sure to avoid damaging the friction material surface.

- 4.3.9 Continue removing the remaining components if required.

- 4.3.10 Inspect all components using the wear limits in Table 8 as a reference.

- 4.3.11 For friction material replacement refer to Section 4.4.





- 4.3.12 For wear plate replacement refer to Section 4.5.

- 4.3.13 For seal replacement refer to Section 4.6.

- 4.3.14 For spring replacement refer to Section 4.7.

- 4.3.15 Assemble the tensioner per Section 4.9.

WCSB tensioner / brake with ORB coolant ports

- | | | |
|--|---|--|
| <p>4.4 Friction Material Replacement</p> <p>Note: When replacing friction material, it is recommended that the mating wear surface be replced or machined flat to ensure good contact between the mating surfaces. See Table 7 for wear limits.</p> |  | <p>Warning
Loctite[®] may cure prior to properly tightening the screw if not tightened to the proper torque value immediately after installation.</p> |
| <p>4.4.1 Refer to Section 6.0 for the appropriate friction disc replacement part numbers.</p> <p>Caution
Use only genuine Airflex friction material. Use of material not of Airflex origin may result in unpredictable performance.</p> |  | <p>Caution
Use only Airflex-supplied screws.</p> |
| <p>4.4.2 Disassemble the WCSB tensioner / brake assembly per Section 4.3.</p> |  | <p>Caution
Loctite[®] #262 must be shaken prior to application.</p> |
| <p>4.4.3 Remove old screws and remove and discard the old friction material.</p> <p>Note: Use of a pinpoint torch to heat the screws and soften the Loctite[®] will ease removal of the screws.</p> |  | <p>Caution
Loctite[®] #262 may irritate sensitive skin. Refer to the product label for proper safety precautions.</p> |
| <p>4.4.4 Clean all burrs, corrosion etc. from the friction disc core or mounting surface.</p> | | <p>4.4.6 36WCSB and 48WCSB friction disc assemblies (7) require that the friction material be machined flat after assembly, to allow for even contact and minimize wear-in. Attach the friction blocks (8) to one side of the disc core (9) and machine the to 748" (19 mm) +/- .010" (.25 mm). Install the friction blocks to the opposite side of the disc core and machine those friction blocks to make a thickness of 2.25" (57,15 mm) for the entire friction disc assembly. The flatness specification is 0.010" (0,25 mm) and the parallelism specification is 0.010" (0,25 mm) for the entire friction disc assembly. The perpendicularity specification is 0.010" (0,25 mm) from the disc blocks to the spline of the disc core.</p> |
| <p>4.4.5 Position the friction material to align the screw holes. Apply Loctite[®] #262 to the screw threads and tighten the screws to the proper torque value. For water-cooled disc assemblies, tighten screws to 15 ft.-lb (20 nm). Screws securing the air cooled brake friction discs (118) or blocks mounted on the pressure plate (13) and end plate subassembly (117) should be tightened to 20 ft-lb (27 nm) after application of Loctite[®] #262 to the screw threads. Install the screws in an even, cross- wise pattern. Screws in friction blocks should be installed from the centermost position in the block, then progressing towards the outer edges of the block. One at a time, install and torque each screw immediately after application of Loctite[®] , then proceed to the next screw.</p> |  | <p>Warning
Use appropriate safety equipment and dust collection systems when machining friction material.</p> |
| | | <p>4.4.7 After replacement of friction material, re-assemble the WCSB tensioner / brake assembly per Section 4.9. Observe wear-in procedures during start-up per Section 3.0, Operation.</p> |

WCSB tensioner / brake with ORB coolant ports

4.5 WC Wear Plate Replacement

Note: As of July, 2014 Wear plate replacement kits for the 24WCSB and 36WCSB are supplied with sealant tape. This is now the preferred method of sealing the water cavity. Wear plate replacement kits for the 24WCSB and 36WCSB prior to July, 2014 used Loctite Superflex® #596 Sealant. Should the wear plate replacement kit being used contain Loctite Superflex® #596 Sealant, refer to capitalize section 4.5.6 for assembly procedures.

Note: When replacing wear surfaces, it is recommended that the mating friction material be replaced or machined flat to ensure good contact between the mating surfaces. See Table 7 for wear limits.

4.5.1 Disassemble WCSB tensioner / brake assembly per Section 4.3.

4.5.2 Remove the screws and locknuts holding the wear plates and remove the wear plates. If the wear plates cannot be easily lifted off, gently tap the O.D. to break the gasket seal.

 **Caution**
Do not attempt to break the gasket seal by prying between the wear plate and housing. Damage to the sealing surfaces may occur.

4.5.3 Inspect the water passages and, if necessary, use a wire brush to clean them. If re-painting is necessary, sand blast the water passages and paint the surfaces with PLASITE® Epoxy #9052 Polyimine coating. Dry film thickness should be 8 to 12 mils (0,2 to 0,3 mm). Be careful not to allow the paint to get into the seal grooves or onto the face of the support nubs.

 **Caution**
Follow manufacturer's instructions and proper safety precautions for application of epoxy coatings.

 **Caution**
If nubs are severely corroded, wear plates may not be properly supported. Replace pressure plate, reaction plate or end plate, if necessary.

4.5.4 For wear plate replacement kits that contain Loctite Superflex® #596 Sealant proceed to section 4.5.6 for assembly instructions.

4.5.5 Assembly with Gasket Tape for sizes 24" and 36"

Note: The End Plate (117a), Pressure Plate (14), and Reaction Plate(s) (31) will be referred to as IRON in the following paragraphs. Refer to Figure 22 for item number references shown in parenthesis (#).

4.5.5.1 Preparation and cleaning the IRON:

Ensure that the IRON surface is smooth and free of paint scale, burrs and corrosion. Thoroughly clean both the inner and outer lands which will receive the gasket. Use a solvent based cleaner such as acetone, mineral spirits or a general-purpose wax / oil / grease remover turning the wipe until it is free of new dark debris. Finish the cleaning process by blowing off lint on the sealing surface.

Caution
Use only clean, dry air for blow-off.

 **Caution**
Follow manufacturer's instructions and proper safety precautions for the use of solvent based cleaners (acetone, mineral spirits or general purpose) for oil/grease remover.

4.5.5.2 Preparation and cleaning the Copper Wear Plate

Ensure that the wear plate surface is smooth and free of burrs and corrosion. Thoroughly clean both the outer and inner areas which will be in contact with the gasket tape. Use a solvent based cleaner such as acetone, mineral spirits, or a general-purpose wax/oil/grease remover. Finish the cleaning process by blowing off lint on the sealing surface.

 **Caution**
Use only clean, dry air for blow-off.

 **Caution**
Follow manufacturer's instructions and proper safety precautions for the use of solvent based cleaners (acetone, mineral spirits or general-purpose) for oil/grease remover.

4.5.5.3 Preparation of the Gasket Tape Ends

Cut the leading and trailing ends of the gasket tape at 45 degrees per Figure 9. This initial step is required to insure a smooth transition of the leading and trailing ends of the tape when it is overlapped per section 4.5.5.4 (b).



Figure 9

WCSB tensioner / brake with ORB coolant ports

4.5.5.4 Applying the Gasket Tape to the IRON.

- (a) Start with the sealing area nearest to the inner diameter on the IRON. Remove the adhesive backing on the gasket tape a little at a time to prevent the adhesive from picking up dirt during installation. Start by positioning one end of the tape at the center-line of a bolt hole as shown in Figure 10, using the edge of the water cavity as a guide as shown in Figure 11. Proceed to apply the tape on the sealing surface following a smooth circular path, being sure to press the tape in place.

Note: The tape will cover the machined groove that is located between the water cavity and the bolt holes.

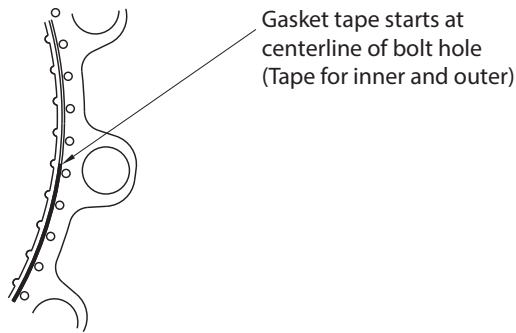

Start location of Gasket Tape

Figure 10

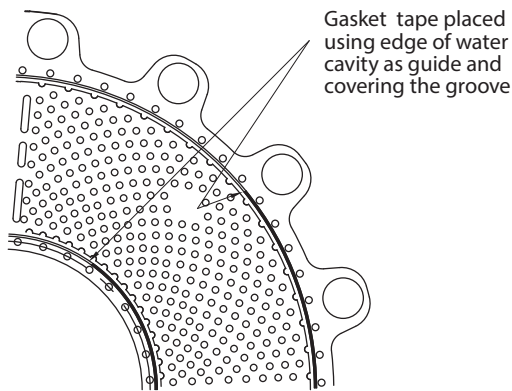

Placement of Gasket Tape

Figure 11

- (b) After the gasket tape has been placed around the entire circumference, overlap the starting end of the tape by a minimum of 0.44" (11,2 mm). See Figure 9. Be sure to smooth the tape at the overlap transition in order to get a good seal. No air gaps or bubbles should be present.
- (c) Repeat steps (a) and (b) in Section 4.5.5.4 for the outer sealing area nearest to the outer diameter of the IRON, again using the edge of the water cavity as a guide.

- 4.5.5.5 Proceed to Section 4.5.7 to complete the wear plate (3) replacement.



Caution

Before the gasket tape is covered with the wear plate, the sealing surface should be protected to prevent contamination from dust, dirt or oils. No additional cleaning or liquid should be applied to the surface of the IRON or gasket tape.

- 4.5.6 Assembly with Loctite Superflex® #596 Sealant

- 4.5.6.1 Clean and completely dry the sealing surfaces at the I.D. and O.D. on the pressure plate (14), reaction plate(s) (31) and end plate (117). These surfaces should be free of nicks and scratches to prevent leaks. Minor nicks and scratches may be filled with Loctite Superflex® #596 Sealant during assembly.

- 4.5.6.2 Apply a uniform bead of Loctite Superflex® #596 Sealant in the grooves of the pressure plate, reaction plate(s) and / or end plate. Recommended bead diameter is 0.060" - 0.090" (1,5 mm - 2,3 mm) for all sizes 24" and 36". For the 48" size, refer to procedure 4.5.6.3 for proper sealant application procedure. For the 24" and 36", skip to capitalize section 4.5.7 after application of sealant.



Caution

Loctite Superflex® #596 Silicon Sealant will begin to set up and skin over in approximately 10 minutes. The wear plate must be fastened to the mating component within 10 minutes of applying the sealant.

- 4.5.6.3 The 48WCSB tensioner / brake assembly incorporates a dual groove for both the Loctite Superflex® #596 Sealant and an O-ring. An initial bead of sealant 0.030" - 0.060" (0,7 mm - 1,5 mm) in size must be applied to the bottom of the deep groove in order to hold the O-ring in place. See Figure 12.

WCSB tensioner / brake with ORB coolant ports

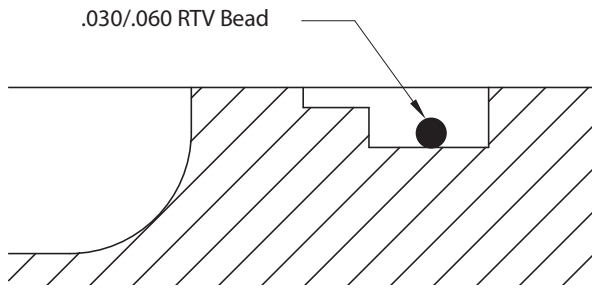

Figure 12

4.5.6.4 Install the O-rings (I.D. and O.D.) on top of the sealant, working them into position so that they lay flat in the bottom of the groove. See Figure 13. A second bead of sealant 0.060" - 0.090" (1,5 mm - 2,3 mm) in size should then be applied in the shallow groove. See Figure 14.

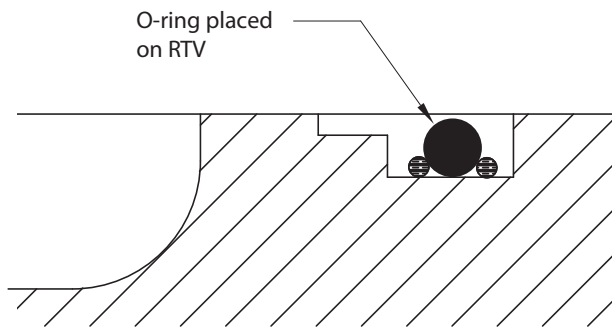

Figure 13

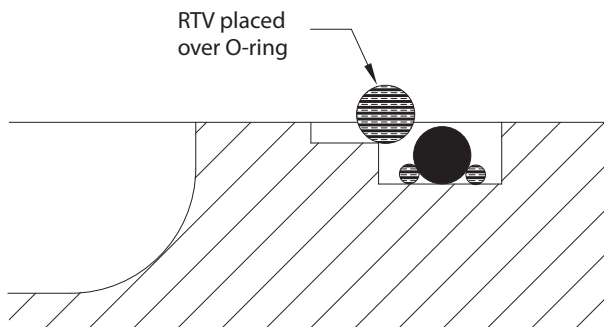

Figure 14

4.5.7 Inspect the new wear plates (3) and remove any scratches or raised edges with very fine sandpaper or steel wool. Position the smoothest side of the wear plate on the sealing surface, being careful to align the holes with those in the IRON.

4.5.8 Position the support rings (50) & (51) over the holes in the wear plates (3) and install the new hex head screws (4) and locknuts (5) provided, securing them finger tight.



Caution

To prevent excessive warping of the wear plate and to endure a good seal, the following torque tightening procedure must be followed.

4.5.9 For each wear plate being replaced, the torque tightening instructions are as follows:

Note: The torque of the screws & nuts (4) (5) that attach the wear plate (3) to the mounting flange (1), reaction plate (30) & pressure plate (13) is a four step process.

(a) For the first 16 screws, bring the initial torque of each screw up to 33% of the torque value shown in Table 2 using the tightening sequence shown in Figure 15. Install and torque the remaining screws in any reasonable crosswise pattern to 33% of the torque value shown in Table 2.

(b) Repeat the sequence of torque tightening on the first 16 screws as shown in Figure 15 and bring each screw up to 66% of the torque value shown in Table 2. Torque the remaining screws in any reasonable crosswise pattern to 66% of the torque value shown in Table 2.

(c) Repeat the sequence of torque tightening on the first 16 screws as shown in Figure 15 and bring each screw up to 100% of the torque value shown in Table 2. Torque the remaining screws in any reasonable crosswise pattern to 100% of the torque value shown in Table 2

(d) Finish torque tightening by selecting a starting position (usually at the 12 o'clock position) and check the 100% torque of each screw going in a sequential clockwise or counterclockwise rotation. Mark or highlight screw head or nut & shank after final torque check as a visual indication that the screw/nut has been tightened to specification shown in Table 2.



Caution

Allow the Loctite Superflex #596 Sealant 24 hours to completely cure before performing the following leak test procedure

WCSB tensioner / brake with ORB coolant ports

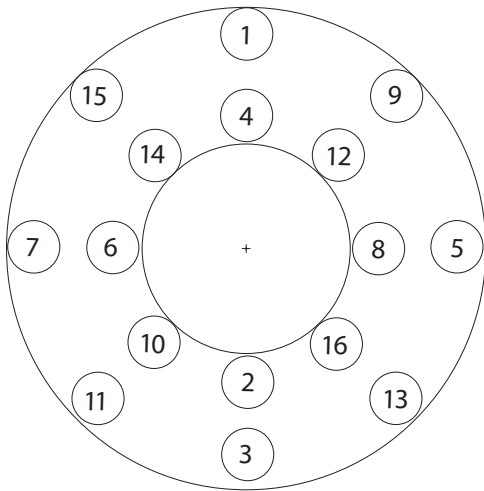

Figure 15

4.5.10 After completion of the assembly, each water cavity should be checked for leaks.

4.5.11 Using lifting straps, suspend each assembly with the water outlet port at the 12 o'clock position. Connect a water supply line to the inlet port (at 6 o'clock position). In reaction plates, plug the remaining inlet port. See Table 4 for water port sizes.

4.5.12 Slowly fill with water to purge all air from water cavities.

Table 10
Inlet and Outlet Water Port Sizes

Size	Size
24WCB2	SAE-12
36WCB2	SAE-20
48WCB2	SAE-20

4.5.13 Install pipe plug(s) in the outlet port(s) and apply appropriate water pressure 40 psig (2.7 bar) for the 36WCSB and 48WCSB and 45 psig (3.1 bar) for the 24WCSB measured at the inlet. Maintain this pressure for a minimum of 30 minutes.

4.5.14 Check for leakage at O.D. and I.D. seal areas. NO leakage is allowed.

4.5.15 If the assembly leaks, check the torque on each screw and re-test. If leaks still occur, the wear plate(s) or sealant groove may be damaged. Repeat procedure from section in front of 4.5.1.

4.5.16 Follow steps in Section 4.9 to reassemble the WCSB tensioner / brake assembly.

4.5.17 Machining of the wear surfaces is required for the 36WCSB and 48WCSB tensioner / brake assemblies after replacement of the wear plates or the adjoining friction material. See Figure 16 for machining specification. Clean all wear surfaces after machining to remove any residual contaminants.

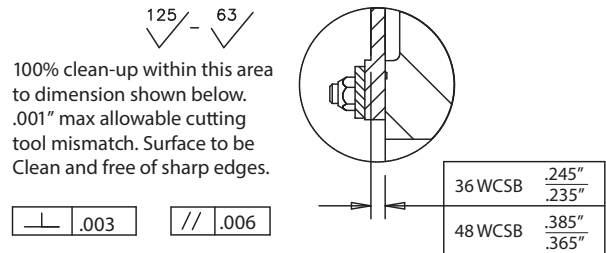

Figure 16

4.6 Cylinder Seal Replacement

Note: If seals in the mounting flange/cylinder (112) require replacement, full disassembly of the WCSB tensioner / brake assembly is required. See Section 4.3.

4.6.1 Disconnect the air supply lines and remove the screws (20), washers (17) and spacer tubes (27) attaching the cylinder (19) to the pressure plate (13).

4.6.2 Carefully slide the cylinder off of the spring housing (16) or piston (33) out of the mounting flange/cylinder (112).



Caution

Do not use compressed air to remove the cylinder from the spring housing.

4.6.3 Remove the cylinder seals from the spring housing (16) or piston (33) and thoroughly clean the seal grooves in the spring housing or spring housing.

4.6.4 Insert new seals into the grooves, noting the orientation of the seals per Figure 17.

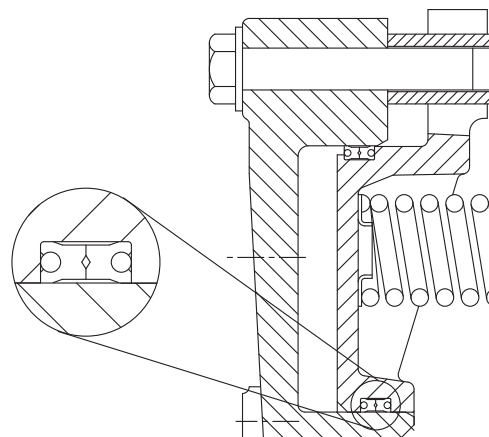

Figure 17

WCSB tensioner / brake with ORB coolant ports

- 4.6.5 Carefully examine the seal surfaces in the cylinder or mounting flange/cylinder. If the surfaces have worn to point as indicated on Table 8, the cylinder must be replaced. Small nicks or scratches must be sanded smooth to prevent air leakage.

Note: If the WCSB tensioner / brake assembly was completely removed and disassembled to replace seals, refer to Section 4.9 to assemble.

- 4.6.6 Lubricate the seal surfaces in the cylinder with Molykote[®] 55 O-ring lubricant and carefully slide the cylinder onto the spring housing. Take special care to avoid damaging the seal lips.

- 4.6.7 Attach the cylinder to the pressure plate with the screws, washers and spacer tubes removed in 4.6.1. Use Loctite[®] Locquic[®] Primer Grade "T" to clean and prepare the screw threads and install with Loctite[®] #262. Using a crosswise pattern, torque the screws to the value shown on Table 2.

 **Warning**
Loctite[®] Primer "T" contains harmful vapors. Refer to the product label for proper safety precautions.

 **Caution**
Loctite[®] #262 must be shaken prior to application.

 **Caution**
Loctite[®] #262 may irritate sensitive skin. Refer to the product label for proper safety precautions.

- 4.6.8 If mounting flange/cylinder seals have been replaced, re-assemble the WCSB tensioner / brake assembly per Section 4.9.

- 4.6.9 Install air lines and air test the assembly for seal leakage per the following:

Apply 120 psig (8.3 bar) to an open port in the cylinder (19) to disengage the spring-set brake and check for release cylinder leakage. Apply 120 psig (8.3 bar) to the larger of the two ports in the mounting flange/cylinder (112) and check for large cylinder seal leakage. Allow the smaller port in the mounting flange/cylinder to remain open to check for potential leakage from the large cylinder to the small cylinder in the mounting flange/cylinder. Shut off the air supply and check for pressure drop from the cylinders. If air pressure does not drop below 100 psig (6.9 bar) within 10 minutes, the seals have been properly installed.

Continue the test by releasing the air pressure in the larger port in the mounting flange cylinder, and applying 120 psig (8.3 bar) to the smaller of the two ports in the mounting flange. The larger port should remain open to atmosphere. Apply 120 psig (8.3 bar) to the cylinder (19) to disengage the spring set brake. Check for leakage from the small cylinder to the large cylinder in the mounting flange/cylinder. Shut off the air supply and check for pressure drop from the cylinders. If air pressure does not drop below 100 psig (6.9 bar) within 10 minutes, the seals have been properly installed.

4.7 Spring Replacement

- 4.7.1 Remove the WCSB tensioner / brake assembly, and disassemble per Section 4.3.

- 4.7.2 Match mark the cylinder (19), spring housing (16), and pressure plate subassembly (13) to one another, to ease reassembly.

- 4.7.3 With the cylinder (19) facing up, disassemble the cylinder/spring housing subassembly by loosening the hex head screws (20) ONE TURN AT A TIME, following a crosswise sequence, until the spring force is relieved. Remove the hex head screws and washers.

 **Caution**
Failure to loosen the screws (20) evenly and in small increments as described may cause the screws or cylinder to bind.

- 4.7.4 Lift and set aside the spring housing (16) and cylinder (19) as a subassembly to expose the springs. Note the locations of the springs and spring retainers (53) refer to Table 17 for 24", Table 18 for 36", and Table 19 for 48" if applicable for reassembly purposes.

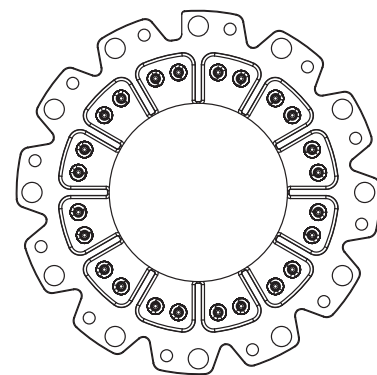

Spring arrangement for 24WCSB

Figure 18

WCSB tensioner / brake with ORB coolant ports

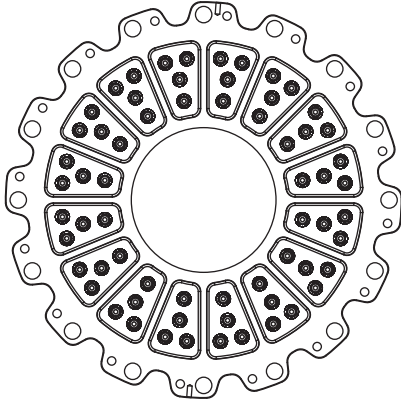

Spring arrangement for 36WCSB

Figure 19

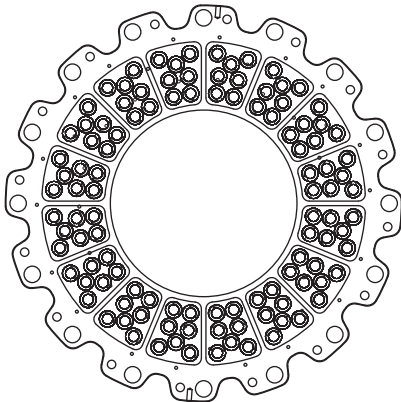

Spring arrangement for 48WCSB

Figure 20

- 4.7.5 Inspect the springs for distortion and check the free height. If the free height of any spring is less than the value shown on Table 7, the entire set of springs must be replaced.
- 4.7.6 Reassemble the WCSB tensioner / brake assembly by following the procedures in Section 4.9., beginning with Section 4.9.20.
-  **Caution**
The cylinder, spring housing and end plate, should not be re-assembled as a separate subassembly. Improper assembly procedures may result in uneven contact of the friction material with the disc (119), resulting in low stopping torque.
- 4.8 Reaction Plate Bushing Replacement (size 36 only)
- 4.8.1 Disassemble the WCSB tensioner / brake assembly per Section 4.3.
- 4.8.2 Refer to Table 8 to determine if the reaction plate bushings (54) require replacement.
- 4.8.3 Heat up the area around each bushing to soften the Loctite[®]. Drive out the old bushings.
- 4.8.4 Clean the bores in the mating component, removing any residual Loctite[®].
- 4.8.5 Apply Loctite[®] #RC601, 635 or 680 to the bushing O.D. and mating hole in the reaction plate using a swab. Apply enough liquid to entirely fill the space between the parts. Install the bushings by twisting the bushing while pushing it down, until it is flush with the casting surface. Inspect to see that a ring of liquid adhesive is visible at the parting line. Reapply Loctite if required. Allow the Loctite to cure for 15 minutes before moving the sub assembly.
- 4.8.6 Assemble the tensioner per Section 4.9, as required.

WCSB tensioner / brake with ORB coolant ports

4.9 Assembly Procedures

4.9.1 Position the mounting flange/cylinder (112) on a flat, level surface, mounting face down. Note the location of the cylinder inlets in the mounting flange as the "6 o'clock" position.

4.9.2 Lubricate the seals (21)(23)(114) with Molykote[®] 55M O-ring lubricant, and install them into the seal grooves on the piston (33). Note the orientation of the seal lips, per Figure 21. Lubricate the seal surfaces in the mounting flange/cylinder (112) and evenly insert the piston into the mounting flange/cylinder.

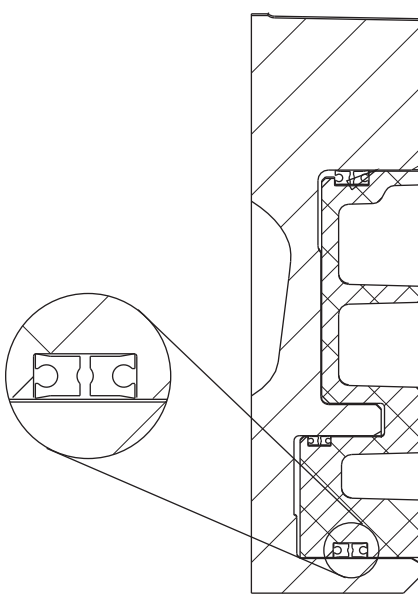

4.9.3 Install the studs (6) into the mounting flange (112). The stud end with the shorter length of threads is to be assembled into the mounting flange. Clean the stud end to be assembled by applying Loctite[®] Loc-Quic[®] Primer Grade "T" to the threads. After the threads have dried, apply Loctite[®] #271 to the threads and assemble the stud until it bottoms in the threaded hole in the mounting flange. Repeat for the remaining studs.



Warning

Loctite[®] Primer "T" contains harmful vapors. Refer to the product label for proper safety precautions

4.9.4 Install a clamp tube (12) over each stud.

4.9.5 With the wear plate facing up, lower the pressure plate subassembly (116) over the clamp tubes, noting the position of the water inlet in relation to the ports in the mounting flange/cylinder. The inlet ports should be as close as possible to the "6 o'clock" position noted in 4.9.1.

4.9.6 Pre-fill the grease channel in the friction disc subassembly (7) splines with MOLUB-ALLOY[®] 936 SF Heavy grease, or equivalent, as shown on Figure 3.

4.9.7 Lower a friction disc subassembly (7) onto the pressure plate wear surface. Center the friction disc on the pressure plate (116).

4.9.8 Place a release spring (34) over every clamp tube. For single disc WCSB tensioner / brake assemblies, proceed to Section 4.9.12.

4.9.9 On multiple disc assemblies, lower a reaction plate subassembly (30) over the clamp tubes, noting the position of the water inlet in relation to the ports in the pressure plate (116).

4.9.10 Assemble a release spring (34) over every clamp tube, and lower a friction disc subassembly (7) onto the reaction plate. Align the disc splines with those in the previous disc assembled to ease installation after assembly.

4.9.11 Repeat Sections 4.9.9 through 4.9.10 until all reaction plates, friction disc assemblies and reaction springs are installed.

4.9.12 Lower the end plate subassembly (117) over the clamp tubes, noting the orientation of the water inlets.

4.9.13 Assemble the wear spacers (29) over the studs (6). Refer to Table 11 for the quantity required at this location (adjacent to clamp tubes (12)) on each stud.

Table 11
Tensioner Wear Spacers

Model	Quantity Required
324WCSB	3
424WCSB	5
336WCSB	3
436WCSB	4
348WCSB	3
448WCSB	4

WCSB tensioner / brake with ORB coolant ports

4.9.14 Assemble the friction discs or blocks (118) to the end plate subassembly (117) and pressure plate (13) per the following: Position the friction material to align the screw holes. Apply Loctite[®] #262 to the screw threads and tighten the screws (121) to 20 ft-lb. (27 nm) Install the screws in an even, cross-wise pattern. Screws in friction blocks should be installed from the centermost position in the block, then progressing towards the outer edges of the block. One at a time, install and torque each screw immediately after application of Loctite[®], then proceed to the next screw.



Warning

Loctite[®] may cure prior to properly tightening the screw if not tightened to the proper torque value immediately after installation.



Caution

Use only Airflex-supplied screws.



Caution

Loctite[®] #262 must be shaken prior to application.



Caution

Loctite[®] #262 may irritate sensitive skin. Refer to the product label for proper safety precautions.

4.9.15 Lower the disc (119) onto the friction material on the end plate subassembly (117), centering it on the friction blocks or disc. Align the splines with those in the tensioner friction disc subassemblies (7).

4.9.16 Assemble the stop plates (125) over adjoining pairs of studs so that they rest against the end plate or wear spacers.

4.9.17 Install the remaining wear spacers (29) over the studs. One spacer should be placed over each stud. See Figure 1

4.9.18 Slide the clamp tubes (124) over the studs.

4.9.19 Lower the pressure plate (13) over the clamp tubes (124), resting the friction material face against the disc (119).

4.9.20 Install the springs in a symmetrical pattern on the pressure plate subassembly (13), distributing them as evenly as possible. Locate the springs over bosses or in the spring pockets in the pressure plate, as shown in Figure 18 for 24WCSB tensioner / brake assemblies, Figure 19 for 36WCSB tensioner / brake assemblies and Figure 20 for 48WCSB tensioner / brake assemblies. If applicable, position the spring retainers (53) on top of the springs to hold the springs into position.

4.9.21 Lower the spring housing and cylinder over the springs and spring retainers, if applicable, aligning the match marks made during disassembly. Be sure to not overlap spring retainers such that they interfere with the ribs in the spring housing (16) when assembled.



Caution

Interference of the spring retainers with the casted ribs in the spring housing will damage the spring retainers and may prevent proper positioning of the springs.

4.9.22 Lubricate the ends of the studs (6) with 30 weight oil or an anti-seize compound, and assemble the locknuts (18) and flat washers (17) onto the studs. Tighten the nuts in an even crosswise pattern ONE TURN AT A TIME to evenly compress the springs. Tighten the nuts to the final tightening torque listed on Table 2

Note: If sleeve nuts (106) are used to accommodate a support bracket, install the sleeve nuts onto the studs in place of the locknuts at or near the "6 o'clock" position, tightening them as required.

4.9.23 Lubricate the seals (21)(23) with Molykote[®] 55M O-ring lubricant, and install them into the seal grooves on the spring housing (16). Note the orientation of the seal lips, per Figure 16.

4.9.24 Lubricate the seal surfaces in the mounting cylinder (19) and lower the cylinder onto the spring housing. Orient the cylinder so that the Danfoss logo is near the "12 o'clock" position, in-line with the water outlets.

4.9.25 Position the spacer tubes (27) in-line with the bolt holes in the cylinder, and install the hex head screws (20) and lock washers (17). Tighten the screws in a crosswise pattern ONE TURN AT A TIME until the spacer tubes are clamped between the cylinder and pressure plate. Make sure the cylinder slides over the seals properly, to avoid damaging the seal lips.

WCSB tensioner / brake with ORB coolant ports

- 4.9.26 Remove the screws (20) one at a time, apply Loctite #262 to the screw threads, and reinstall the screw, tightening to the value shown in Table 2. Repeat for the remaining screws.



Warning
Loctite[®] may cure prior to properly tightening the screw if not tightened to the proper torque value immediately after installation.



Caution
Loctite[®] #262 must be shaken prior to application.



Caution
Loctite[®] #262 may irritate sensitive skin. Refer to the product label for proper safety precautions.



Caution
The locknuts (18) and sleeve nuts (106) must be tightened gradually to prevent damage to the brake components.

- 4.9.27 After assembly, check gaps "W" and "Z-1" to ensure that the brake will have adequate running clearances when released. Refer to Figure 7 and Table 9. Additional machining of friction discs or wear plates may be required to achieve proper running clearances if gaps W_{new} and Z_{new} are not found to be within the ranges shown on Table 8. Correct as required.

- 4.9.28 Prior to installation, air test the cylinder seals for leakage per Section 4.6.9.

- 4.9.29 Install the WCSB tensioner per Section 2.0.

5.0 ORDERING INFORMATION / TECHNICAL ASSISTANCE

5.1 Equipment Reference

- 5.1.1 In any correspondence regarding Airflex equipment, refer to the information on the product nameplate and call or write:

Loctite, Locquic, and Superflex are registered trademarks of Henkle Corporation.

Molykote[®] is a registered trademark of Dow Corning

PLASITE Epoxy #9052 is a registered trademark of The Carbolite Company.

MOLUB-ALLOY is a trademark of Castrol Industrial Lubricants.

WCSB tensioner / brake with ORB coolant ports

6.0 PART LISTS

6.1 Basic Assemblies 24WCSB Parts

Item	Description	224 WCSB	Qty	324 WCSB	Qty	424 WCSB	Qty
		146452T Part Number		146453T Part Number		146477T Part Number	
6	Stud	000245X0116	12	000245X0113	12	000245X0115	12
7	Friction Disc Assembly	513964-03	1	513964-03	2	513964-03	3
12	Clamp Tube	308206-11	12	308206-06	12	308206-10	12
13	Pressure Plate	513335	1	513335	1	513335	1
16	Spring Housing	513268	1	513268	1	513268	1
17	Flat Washer	000153X0641	24	000153X0641	24	000153X0641	24
18	Self Locking Nut	000110X0073	12	000110X0073	12	000110X0073	12
19	Cylinder	513264	1	513264	1	513264	1
20	Hex Head Screw	000197X1035	12	000197X1035	12	000197X1035	12
21	Seal	000402X0023	4	000402X0023	4	000402X0023	4
22	Spring	416751-09	24	416751-09	24	416751-09	24
23	Seal	000402X0024	4	000402X0024	4	000402X0024	4
27	Spacer Tube	308206-09	12	308206-09	12	308206-09	12
28	Gear (Not Included)	410970-####	-	412433-####	-	413195-####	-
29	Wear Spacer	308348	24	308348	48	308348	72
30	Reaction Plate Sub-Assembly	-	-	515661-02	1	515661-02	2
33	Dual Piston	514545	1	514545	1	514545	1
34	Release Spring	416751-02	12	416751-02	24	416751-02	36
52	Inner Spring	416751-10	24	416751-10	24	416751-10	24
53	Spring Retainer	307969	24	307969	24	307969	24
105	Pipe Plug	000077X0021	1	000077X0021	1	000077X0021	1
112	Mounting Flange / Cylinder	514509	1	514509	1	514509	1
114	Seal	000402X0041	2	000402X0041	2	000402X0041	2
116	Pressure Plate Sub-Assembly	515661-03	1	515661-03	1	515661-03	1
117	End Plate Sub-Assembly	514676	1	514676	1	514676	1
118	Friction Disc / Block	513307	2	513307	2	513307	2
119	Disc	514348	1	514348	1	514348	1
121	Flat Head Screw	000294X0405	48	000294X0405	48	000294X0405	48
122	Pipe Plug	000076X0006	5	000076X0006	5	000076X0006	5
124	Clamp Tube	308206-07	12	308206-07	12	308206-07	12
125	Stop Plate	308349	6	308349	6	308349	6
127	Pipe Plug	000076X0006	3	000076X0006	3	000076X0006	3

WCSB tensioner / brake with ORB coolant ports

6.2 Basic Assemblies 36WCSB Parts

Item	Description	236 WCSB 146436T Part Number	Qty	336 WCSB 146477T Part Number	Qty	436 WCSB 146402T Part Number	Qty
6	Stud	307111-18	16	307111-17	16	307111-15	16
7	Friction Disc Assembly	514766	1	514766	2	514766	3
12	Clamp Tube	308246-12	16	308246-11	16	308246-05	16
13	Pressure Plate	513985-03	1	513985-03	1	513985-03	1
16	Spring Housing	514125	1	514125	1	514125	1
17	Flat Washer	000067X0042	32	000067X0042	32	000067X0042	37
18	Self Locking Nut	000110X0075	16	000110X0075	16	000110X0075	16
19	Cylinder	513988	1	513988	1	513988	1
20	Hex Head Screw	417178-01	16	417178-01	16	417178-01	16
21	Seal	000402X0005	4	000402X0005	4	000402X0005	4
22	Outer Spring	416751-07	64	416751-07	64	416751-07	64
23	Seal	000402X0006	4	000402X0006	4	000402X0006	4
27	Spacer Tube	308150-06	16	308150-06	16	308150-06	16
28	Gear (Not Included)	416821-####	---	416842-####	---	416676-####	---
29	Wear Spacer	308313	32	308313	64	308313	80
30	Reaction Plate Sub-Assembly	---	---	515617-01	1	515617-01	2
33	Dual Piston	514485	1	514485	1	514485	1
34	Release Spring	416751-01	16	416751-01	32	416751-01	48
52	Inner Spring	416751-08	64	416751-08	64	416751-08	64
53	Spring Retainer	416504	16	416504	16	416504	16
105	Pipe Plug	000077X0021	1	000077X0021	1	000077X0021	1
106	Sleve Nut	---	---	---	---	308242	5
112	Mounting Flange / Cylinder	514507	1	514507	1	514507	1
114	Seal	000402X0040	2	000402X0040	2	000402X0040	2
116	Pressure Plate Sub-Assembly	515616-01	1	515616-01	1	515616-01	1
117	End Plate Sub-Assembly	515616-02	1	515616-02	1	515616-02	1
118	Friction Disc / Block	513396	2	513396	2	513396	2
119	Disc	515336	1	515336	1	515336	1
121	Flat Head Screw	000294X0405	72	000294X0405	72	000294X0405	72
122	Pipe Plug	000076X0007	5	000076X0007	5	000076X0007	5
124	Clamp Tube	308246-06	16	308246-06	16	308246-06	16
125	Stop Plate	308312	8	308312	8	308312	8
127	Pipe Plug	000076X0006	3	000076X0006	3	000076X0006	3

WCSB tensioner / brake with ORB coolant ports

6.3 Basic Assemblies 48WCSB Parts

Item	Description	248 WCSB	Qty	348 WCSB	Qty	448 WCSB	Qty
		146478T Part Number		146400T Part Number		146479T Part Number	
6	Stud	307111-12	16	307111-16	16	307111-19	16
7	Friction Disc Assembly	514767	1	514767	2	514767	3
12	Clamp Tube	308440-09	16	308440-01	16	308440-04	16
13	Pressure Plate	514330	1	514330	1	514330	1
16	Spring Housing	514506	1	514506	1	514506	1
17	Flat Washer	67 x 0042	32	67 x 0042	37	67 x 0042	37
18	Self Locking Nut	000110X0075	16	000110X0075	16	000110X0075	16
19	Cylinder	514516	1	514516	1	514516	1
20	Hex Head Screw	197X1347	16	197X1347	16	197X1347	16
21	Seal	000402X0042	4	000402X0042	4	000402X0042	4
22	Spring	416751-03	112	416751-03	112	416751-03	112
23	Seal	000402X0044	4	000402X0044	4	000402X0044	4
27	Spacer Tube	308440-03	16	308440-03	16	308440-03	16
28	Gear (Not Included)	416795-####	---	416688-####	---	416797-####	---
29	Wear Spacer	308315	32	308315	64	308315	80
30	Reaction Plate Sub-Assembly	---	---	515601-02	1	515601-02	2
33	Dual Piston	514484	1	514484	1	514484	1
34	Release Spring	416751-04	16	416751-04	32	416751-04	48
53	Spring Retainer	416674	16	416674	16	416674	16
105	Pipe Plug	000077X0021	1	000077X0021	1	000077X0021	1
106	Sleeve Nut	---	---	308242	5	308242	5
112	Mounting Flange / Cylinder	514332	1	514332	1	514332	1
114	Seal	000402X0043	2	000402X0043	2	000402X0043	2
116	Pressure Plate Sub-Assembly	515601-01	1	515601-01	1	515601-01	1
117	End Plate Sub-Assembly	515601-03	1	515601-03	1	515601-03	1
118	Friction Disc / Block	416691	18	416691	18	416691	18
119	Disc	514511	1	514511	1	514511	1
121	Flat Head Screw	000294X0405	90	000294X0405	90	000294X0405	90
122	Pipe Plug	000076X0005	5	000076X0005	5	000076X0005	5
124	Clamp Tube	308440-02	16	308440-02	16	308440-02	16
125	Stop Plate	308314	8	308314	8	308314	8
127	Pipe Plug	000076X0006	3	000076X0006	3	000076X0006	3

WCSB tensioner / brake with ORB coolant ports

6.4 Sub-Assemblies (Standard)

6.4.1 Parts Breakdown of WCSB Reaction Plate Sub-Assemblies (Item 30). Reference: Figure 22.

Size Sub-Assembly Part Number Item Description	24 WCSB 51 5661-02 Part Number	Qty	36 WCSB 51 5617-01 Part Number	Qty	48 WCSB 51 5601-02 Part Number	Qty
31 Reaction Plate	515663	1	515609	1	515603	1
3 Wear Plate	508459	2	416527	2	416690	2
4 Wear Plate Screw	000153X0685	90	000153X0842	108	000153X1224	120
5 Locknut	000153X0642	90	000153X0844	108	000153X0844	120
50 Inner Support Ring	413107	6	414032-01	12	416618	10
51 Outer Support Ring	413108	10	414033-01	18	416673	20
I Inner O-ring	N/A	N/A	N/A	N/A	000073X0410	2
O Outer O-ring	N/A	N/A	N/A	N/A	000073X0411	2

6.4.2 Parts Breakdown of WCSB Pressure Plate Sub-Assemblies (Item 116). Reference: Figure 22.

Size Sub-Assembly Part Number Item Description	24 WCSB 51 5661-03 Part Number	Qty	36 WCSB 51 5616-01 Part Number	Qty	48 WCSB 51 5601-01 Part Number	Qty
14 Pressure Plate	515664	1	515611	1	515602	1
3 Wear Plate	508459	1	416527	1	416690	1
4 Wear Plate Screw	000153X0685	90	000153X0842	72	000153X1223	120
4a Wear Plate Screw	N/A	N/A	000153X1216	36	N/A	N/A
5 Locknut	000153X0642	90	000153X0844	108	000153X0844	120
50 Inner Support Ring	413107	3	414032-01	6	416618	5
51 Outer Support Ring	413108	5	414033-01	9	416673	10
I Inner O-ring	N/A	N/A	N/A	N/A	000073X0410	1
O Outer O-ring	N/A	N/A	N/A	N/A	000073X0411	1

6.4.3 Parts Breakdown of WCSB End Plate Sub-Assemblies (Item 117). Reference: Figure 22.

Size Sub-Assembly Part Number Item Description	24 WCSB 51 4676 Part Number	Qty	36 WCSB 51 5616-02 Part Number	Qty	48 WCSB 51 5601-03 Part Number	Qty
3 Wear Plate	508459	1	416527	1	416690	1
4 Wear Plate Screw	000153X0685	90	000153X0842	72	000153X1225	80
4a Wear Plate Screw	N/A	N/A	000153X1216	36	000153X0842	40
5 Locknut	000153X0642	90	000153X0844	108	000153X0844	120
50 Inner Support Ring	413107	3	414032-01	6	416618	5
51 Outer Support Ring	413108	5	414033-01	9	416673	10
117a End Plate	515677	1	515610	1	515604	1
I Inner O-ring	N/A	N/A	N/A	N/A	000073X0410	1
O Outer O-ring	N/A	N/A	N/A	N/A	000073X0411	1

6.4.4 Parts Breakdown of WCSB Friction Disc Sub-Assemblies (Item 7). Reference: Figure 22.

Size Sub-Assembly Part Number Item Description	24 WCSB 51 3964-03 Part Number	Qty	36 WCSB 51 4766 Part Number	Qty	48 WCSB 51 4767 Part Number	Qty
8 Friction Disc	514711	2	514707	16	514708	16
9 Friction Disc Core	510745	1	513667	1	514287	1
57 Screw	000421X0407	36	000294X0407	144	000042X0407	224

WCSB tensioner / brake with ORB coolant ports

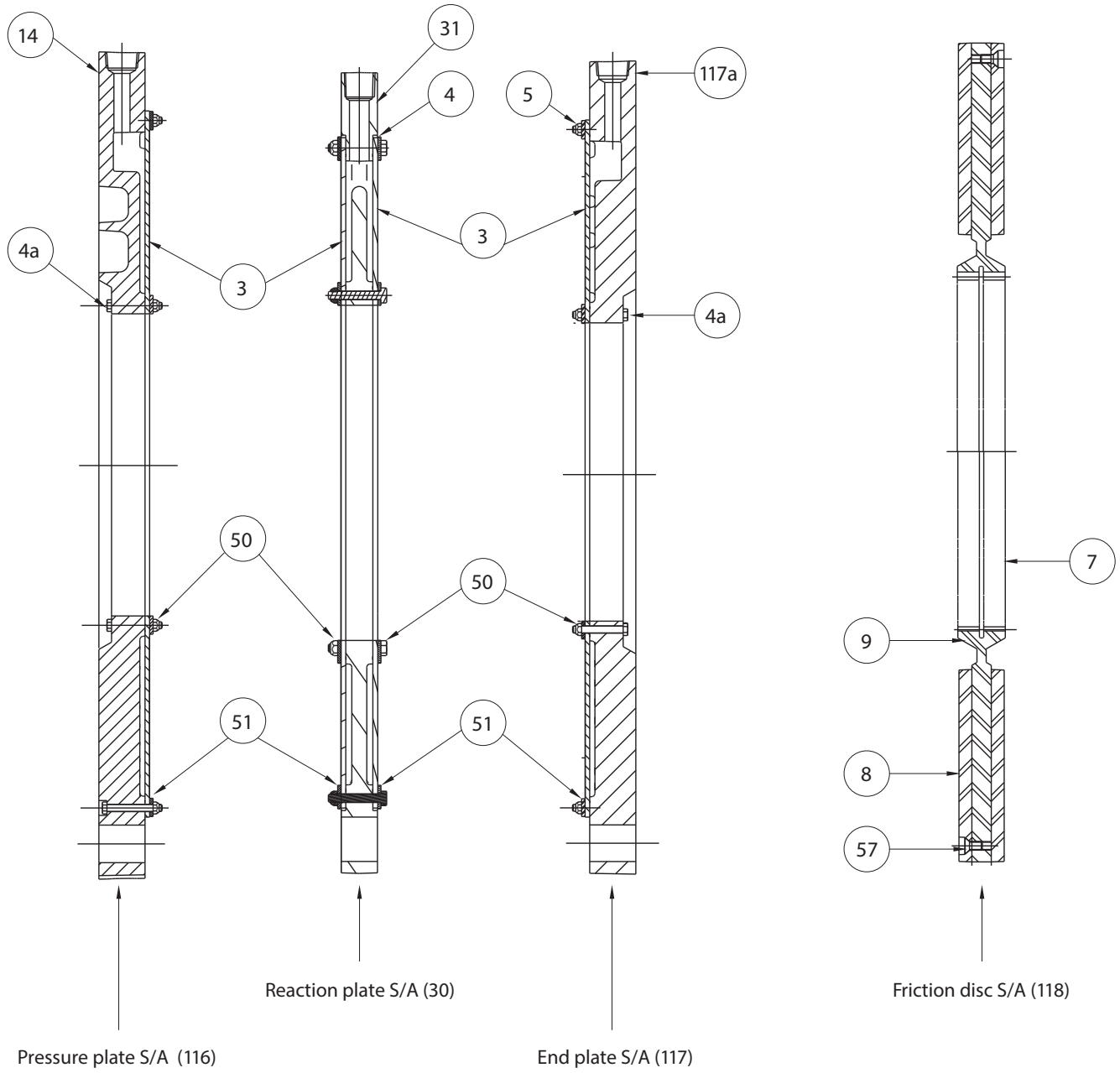

Figure 22

WCSB tensioner / brake with ORB coolant ports

7.0 KITS

7.1 Wear Plate Kit for End Plate and Pressure Plate

Parts Included in Kit

Size	Kit P/N	Description	Screw (4)	Screw (4a)	Lock Nut (5)	Wear Plate (3)	Inner Support Ring (50)	Outer Support Ring (51)	PTFE Gasket (O.D.)	PTFE Gasket (I.D.)	Instruction Sheet
24WCSB	107727A	Part No. Quantity	000153X0642 180	N/A N/A	000153X0685 180	508459 2	413107 6	413108 10	308581-01 2	308581-02 2	204063 1
36WCSB	108059A	Part No. Quantity	000153X0842 144	000153X1216 72	000153X0844 216	416527 2	414032-01 12	414033-01 18	308581-01 2	308581-02 2	204063 1

Size	Kit P/N	Description	Screw Pressure Plate (4)	Screw End Plate (4)	Screw End Plate (3)	Lock Nut (5)	Wear Plate (3)	Inner Support Ring (50)	Outer Support Ring (51)	Inner O-Ring (I)	Outer O-Ring (O)	Loctite #596	Instruction Sheet
48WCSB	108046A	Part No. Quantity	000153X1223 120	000153X1225 80	000153X0842 40	000153X0844 240	416690 2	416618 10	416673 20	000073X0410 2	000073X0411 2	000153X1071 3	204063 1

7.2 Wear Plate Kit for Reaction Plate

Parts Included in Kit

Size	Kit P/N	Description	Screw (4)	Lock Nut (5)	Wear Plate (3)	Inner Support Ring (50)	Outer Support Ring (51)	PTFE Gasket (O.D.)	PTFE Gasket (I.D.)	Instruction Sheet
24WCSB	107727E	Part No. Quantity	000153X0642 90	000153X0685 90	508459 2	413107 6	413108 10	308581-01 2	308581-02 2	204063 1
36WCSB	107662E	Part No. Quantity	000153X0843 108	000153X0844 108	416527 2	414032-01 12	414033-01 18	308581-01 2	308581-02 2	204063 1

Size	Kit P/N	Description	Screw (4)	Lock Nut (5)	Wear Plate (3)	Inner Support Ring (50)	Outer Support Ring (51)	Inner O-Ring (I)	Outer O-Ring (O)	Loctite #596	Instruction Sheet
48WCSB	108855E	Part No. Quantity	000153X1224 120	000153X0844 120	416690 2	416618 10	416673 20	000073X0410 2	000073X0411 2	000153X1071 3	204063 1

7.3 Cylinder Seal Kit (Spring Apply)

Parts Included in Kit

Size	Kit P/N	Description	Lip Seal (Inner) (21)	Lip Seal (Outer) (23)	Seal Lubricant	Instruction Sheet
24WCSB	107727C	Part No. Quantity	000402X0023 2	000402X0024 2	000153X1239 1	204067 1
36WCSB	107662C	Part No. Quantity	000402X0005 2	000402X0006 2	000153X1239 1	204067 1
48WCSB	108055C	Part No. Quantity	000402X0042 2	000402X0044 2	000153X1239 1	204067 1

7.4 Cylinder Seal Kit (Air Apply)

Parts Included in Kit

Size	Kit P/N	Description	Lip Seal (Inner) (21)	Lip Seal (Intermediate) (114)	Lip Seal (Outer) (23)	Seal Lubricant	Instruction Sheet
24WCSB	107727CD	Part No. Quantity	000402X0023 2	000402X0041 2	000402X0024 2	000153X1239 1	204183 1
36WCSB	107662CD	Part No. Quantity	000402X0005 2	000402X0040 2	000402X0006 2	000153X1239 1	204183 1
48WCSB	108055CD	Part No. Quantity	000402X0042 2	000402X0043 2	000402X0044 2	000153X1239 1	204183 1

WCSB tensioner / brake with ORB coolant ports

7.5 WC Friction Disc Kit (Standard)

Parts Included in Kit

Model	Kit P/N	Description	Friction Disc (8)	Wear Spacer (29)	Flat Head S crew (57)	Loctite * #262 Sealant	Instruction Sheet
224WCSB	108056B	Part No. Quantity	514711 2	308348 12	000294X0407 36	000153X1016 1	204097 1
324WCSB	108056BA	Part No. Quantity	514711 4	308348 36	000294X0407 72	000153X1016 2	204097 1
424WCSB	108056BB	Part No. Quantity	514711 6	308348 60	000294X0407 108	000153X1016 3	204097 1
236WCSB	108059B	Part No. Quantity	514707 16	308313 16	000294X0407 144	000153X1168 1	204097 1
336WCSB	108059BA	Part No. Quantity	514707 32	308313 48	000294X0407 288	000153X1168 2	204097 1
436WCSB	108059BB	Part No. Quantity	514707 48	308313 64	000294X0407 432	000153X1168 3	204097 1
248WCSB	108046B	Part No. Quantity	514708 16	308315 16	000294X0407 224	000153X1168 2	204097 1
348WCSB	108046BA	Part No. Quantity	514708 32	308315 48	000294X0407 448	000153X1168 3	204097 1
448WCSB	108046BB	Part No. Quantity	514708 48	308315 64	000294X0407 672	000153X1168 5	204097 1

7.6 AC Friction Disc Kit (Standard)

Parts Included in Kit

Size	Kit P/N	Description	Friction Disc (8)	Wear Spacer (29)	Flat Head S crew (57)	Loctite * #262 Sealant	Installation, Operation, & Maintenance Manual
24WCSB	108057B	Part No. Quantity	513307 2	308348 12	000294X0407 36	000153X1168 1	204170 1
36WCSB	108047B	Part No. Quantity	513396 2	308313 16	000294X0405 72	000153X1168 1	204170 1
48WCSB	108048B	Part No. Quantity	416691 18	308315 16	000294X0405 90	000153X1168 2	204170 1

7.7 WC Friction Disc Kit (Crossion Resistant)

Parts Included in Kit

Model	Kit P/N	Description	Friction Disc (8)	Wear Spacer (29)	Flat Head S crew (57)	Loctite * #262 Sealant	936SF MOLUB-ALL OY	Instruction Sheet
236WCSB	108059C	PartNo. Quantity	514707 16	308313 16	000421X0407 144	000153X1168 1	000153X1182 1	204130 1
336WCSB	108059CA	PartNo. Quantity	514707 32	308313 48	000421X0407 288	000153X1168 2	000153X1182 1	204130 1
436WCSB	108059CB	PartNo. Quantity	514707 48	308313 64	000421X0407 432	000153X1168 3	000153X1182 1	204130 1
248WCSB	108046C	PartNo. Quantity	514708 16	308315 16	000421X0407 224	000153X1168 2	000153X1182 1	204130 1
348WCSB	108046CA	PartNo. Quantity	514708 32	308315 48	000421X0407 448	000153X1168 3	000153X1182 1	204130 1
448WCSB	108046CB	PartNo. Quantity	514708 48	308315 64	000421X0407 672	000153X1168 5	000153X1182 1	204130 1

7.8 AC Friction Disc Kit (Crossion Resistant)

Parts Included in Kit

Size	Kit P/N	Description	Friction Disc (8)	Wear Spacer (29)	Flat Head S crew (57)	Loctite * #262 Sealant	936SF MOLUB-ALL OY	Installation, Operation, & Maintenance Manual
36WCSB	108047C	PartNo. Quantity	513396 2	308313 16	000421X0407 72	000153X1168 1	000153X1182 1	204170 1
48WCSB	108048C	PartNo. Quantity	416691 18	308315 16	000421X0407 90	000153X1168 2	000153X1182 1	204170 1

WCSB tensioner / brake with ORB coolant ports

8.0 REVISIONS

Original Publication Date: August 2014

Re vision Date	Change
----------------	--------

Products we offer:

- Cartridge valves
- DCV directional control valves
- Electric converters
- Electric machines
- Electric motors
- Gear motors
- Gear pumps
- Hydraulic integrated circuits (HICs)
- Hydrostatic motors
- Hydrostatic pumps
- Orbital motors
- PLUS+1® controllers
- PLUS+1® displays
- PLUS+1® joysticks and pedals
- PLUS+1® operator interfaces
- PLUS+1® sensors
- PLUS+1® software
- PLUS+1® software services, support and training
- Position controls and sensors
- PVG proportional valves
- Steering components and systems
- Telematics

Hydro-Gear

www.hydro-gear.com

Daikin-Sauer-Danfoss

www.daikin-sauer-danfoss.com

Danfoss Power Solutions is a global manufacturer and supplier of high-quality hydraulic and electric components. We specialize in providing state-of-the-art technology and solutions that excel in the harsh operating conditions of the mobile off-highway market as well as the marine sector. Building on our extensive applications expertise, we work closely with you to ensure exceptional performance for a broad range of applications. We help you and other customers around the world speed up system development, reduce costs and bring vehicles and vessels to market faster.

Danfoss Power Solutions – your strongest partner in mobile hydraulics and mobile electrification.

Go to www.danfoss.com for further product information.

We offer you expert worldwide support for ensuring the best possible solutions for outstanding performance. And with an extensive network of Global Service Partners, we also provide you with comprehensive global service for all of our components.

Local address:

**Danfoss
Power Solutions (US) Company**
2800 East 13th Street
Ames, IA 50010, USA
Phone: +1 515 239 6000

**Danfoss
Power Solutions GmbH & Co. OHG**
Krokamp 35
D-24539 Neumünster, Germany
Phone: +49 4321 871 0

**Danfoss
Power Solutions ApS**
Nordborgvej 81
DK-6430 Nordborg, Denmark
Phone: +45 7488 2222

**Danfoss
Power Solutions Trading
(Shanghai) Co., Ltd.**
Building #22, No. 1000 Jin Hai Rd
Jin Qiao, Pudong New District
Shanghai, China 201206
Phone: +86 21 2080 6201

Danfoss can accept no responsibility for possible errors in catalogues, brochures and other printed material. Danfoss reserves the right to alter its products without notice. This also applies to products already on order provided that such alterations can be made without subsequent changes being necessary in specifications already agreed. All trademarks in this material are property of the respective companies. Danfoss and the Danfoss logotype are trademarks of Danfoss A/S. All rights reserved.