



# DBBS Brakes

## General Information

### Warning

Forward this manual to the person responsible for Installation, Operation and Maintenance of the product described herein. Without access to this information, faulty Installation, Operation or Maintenance may result in personal injury or equipment damage.

### Caution

#### Use Only Genuine Airflex Replacement Parts

The Airflex Division of Danfoss Power Solutions recommends the use of genuine Airflex replacement parts. The use of non-genuine Airflex replacement parts could result in substandard product performance, and may void your Danfoss warranty. For optimum performance, contact Airflex:

# DBBS Brakes

## Table of Contents

1.0	INTRODUCTION .....	06
1.1	Description .....	06
1.2	How It Works .....	06
2.0	INSTALLATION .....	06
2.1	Alignment .....	06
2.2	Mounting .....	07
2.3	Air Supply System .....	08
3.0	OPERATION .....	09
3.1	Pressure and Speed Limits .....	09
3.2	Initial Operation .....	09
3.3	Periodic Inspection .....	11
4.0	MAINTENANCE .....	11
4.1	Wear Limits .....	11
4.2	Wear Adjustment .....	11
4.3	Friction Disc Replacement .....	17
4.4	Cylinder Seal Replacement .....	19
4.5	Spring Replacement .....	20
5.0	ORDERING INFORMATION / TECHNICAL ASSISTANCE .....	22
6.0	PARTS LISTS .....	23
6.1	Basic Assemblies .....	23

# DBBS Brakes

## Index of Tables

Table No.	TableTitle	Page No.
1	Item Descriptions	5
2	Alignment Requirements	7
3	Brake Sizes Requiring Rigid Support	7
4	Fastener Description and Assembly Torque	8
5	Maximum Disc Speeds	9
6	Wear-in Parameters	9
7	Wear Limits for DBBS Components	13
8	Wear Gap Values	14
9	Power Head Weights	14

## Index of Figures

Figure No.	FigureTitle	Page No.
1	DBBS Cross Section and Item Numbers	5
2	Proper vs Improper Alignment of DBBS	7
3	Clutch/Brake Overlap	11
4	Dust/Wear Grooves & Wear Step in Friction Discs	12
5	Wear Adjustment Gap Location	14
6	DBBS Single Disc	15
7	DBBS Two Disc	15
8	DBBS Three Disc	15
9	DBBS Four Disc	15
10	Solid Wear Spacer (stored) Location	16
11	Split Wear Spacer (removal)	17
12	Cylinder Seal Orientation	19

# DBBS Brakes

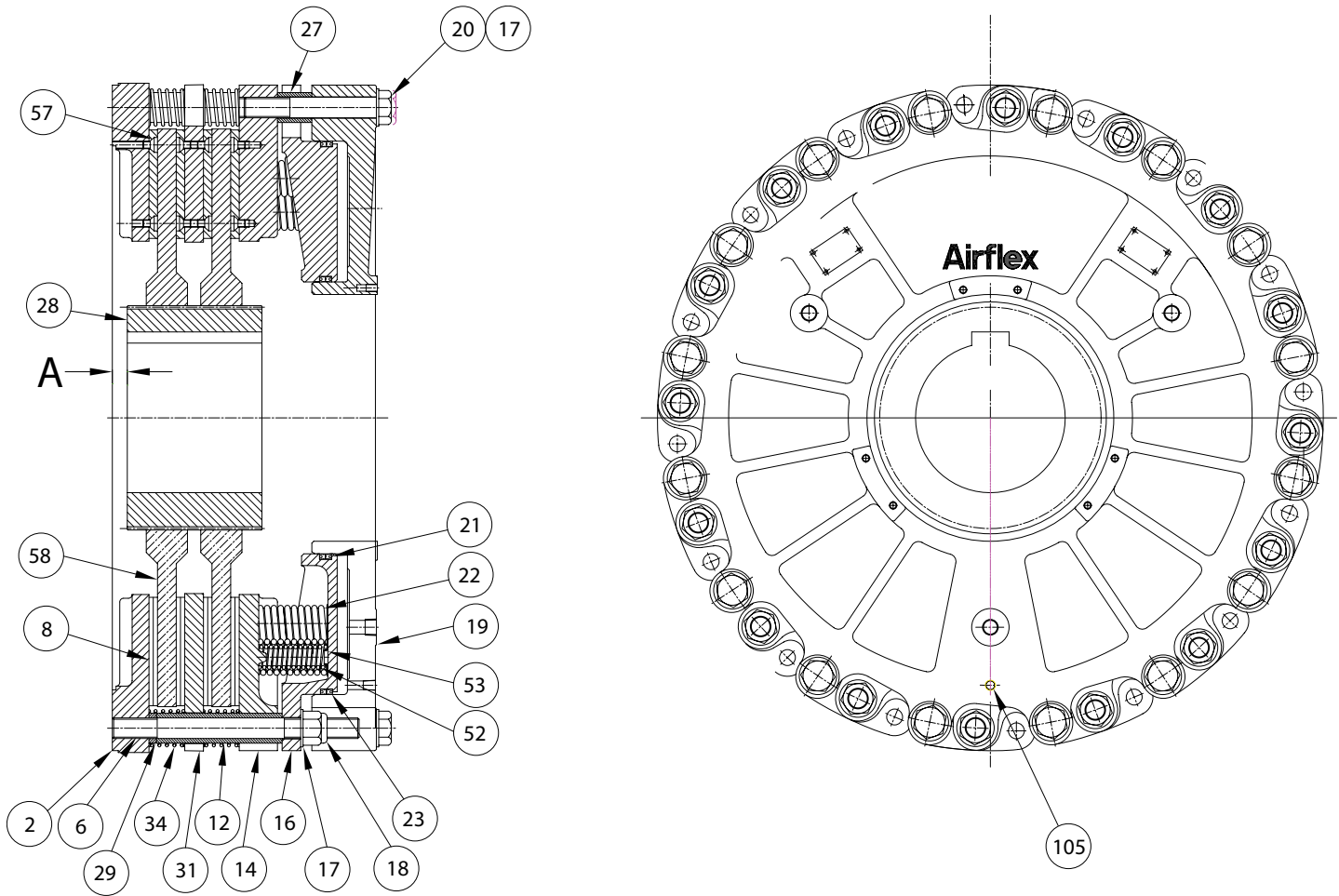

Figure 1 (2 Disc DBBS)

Table 1  
Item Description

ITEM	DESCRIPTION
2	Mounting Flange
6	Stud
8	Friction Disc
12	Clamp Tube
14	Pressure Plate
16	Spring Housing
17	Flat Washer
18	Locknut
19	Cylinder
20	Hex Head Screw
21	Inner Lip Seal
22	Spring

Item Description

ITEM	DESCRIPTION
23	Outer Lip Seal
27	Spacer Tube
28	Gear
29	Wear Spacer
31	Reaction Plate
34	Release Spring
52	Inner Spring
53	Spring Retainer
57	Flat Head Screw
58	Disc
105	Brass Pipe Plug

# DBBS Brakes

## 1.0 Introduction

Throughout this manual there are a number of HAZARD WARNINGS that must be read and adhered to in order to prevent possible personal injury and/or damage to equipment. Three signal words "DANGER", "WARNING", and "CAUTION" are used to indicate the severity of a hazard, and are preceded by the safety alert symbol . 



### Danger

Denotes the most serious hazard, and is used when serious injury or death WILL result from misuse or failure to follow specific instructions.



### Warning

Used when serious injury or death MAY result from misuse or failure to follow specific instructions.



### Caution

Used when injury or product / equipment damage may result from misuse or failure to follow specific instructions.

It is the responsibility and duty of all personnel involved in the installation, operation, and maintenance of the equipment on which this device is used to fully understand the ! Danger ! Warning and ! Caution procedures by which hazards are to be avoided.

## 1.1 Description

1.1.1 The Airflex Model DBBS brakes were designed for heavy-duty industrial applications where spring set (power off) braking is required.

1.1.2 All Airflex DBBS brakes are supplied with long wearing, Non-Asbestos Friction material and solid cast, rotating discs.

1.1.3 Airflex DBBS brakes are available in four basic sizes and can be supplied as single, dual, triple or quadruple disc units. The model number identifies the number of discs and the disc diameter. For example, 225DBBS indicates the brake uses two 25 inch diameter discs. When size, such as 25DBBS is referred to in this manual, it means that the information given applies to all DBBS models using 25 inch diameter discs; i.e. 125DBBS, 225DBBS, etc...

1.1.4 This manual includes metric equivalents usually shown in parentheses ( ) following the U.S. measurement system value. Be sure to use the correct value.

## 1.2 How It Works

1.2.1 Referring to Figure 1 and Table 1, the gear (28) is mounted on the shaft which is to be stopped. The brake assembly is attached to the machine frame or reaction bracket. As air pressure is applied through the ports in the cylinder (19), the cylinder and pressure plate (14), which are attached to each other with screws (20), flat washers (17) and spacer tubes (27), move away from the mounting flange (2), which is connected to the machine frame or reaction bracket. The pressure plate compresses the springs (22) (52) against the stationary spring housing (16) and the clamp force is removed from the discs (58) which ride on the gear. The shaft is then free to rotate.

1.2.2 As air pressure is exhausted, the springs (22) force the pressure plate (14) toward the mounting flange (2), clamping the rotating discs (58) between the stationary friction discs (8) which are attached to the pressure plate (14) and mounting flange (2). On two, three and four disc models, a reaction plate (31), to which friction discs are mounted, and an additional disc are clamped between the pressure plate and mounting flange.

## 2.0 Installation



### Danger

Prior to installation of the DBBS brake, make sure that the machinery will remain in a secured position. Failure to do so could result in serious personal injury or possibly death.

## 2.1 Alignment

2.1.1 For proper operation and service life, the DBBS brake must be mounted concentric and at right angles to the shaft within the limits shown on Table 2.



### CAUTION

Proper alignment is necessary to assure that the discs (58) will track properly. Improper alignment will result in excessive wear to the friction discs (8), discs (58) and gear (28). See Figure 2.

# DBBS Brakes

TABLE 2  
Alignment Requirements

Size	Concentricity (Parallel, TIR) of Shaft and Element (Inches (mm))	Perpendicularly (Angular, TIR) of Mounting Flange to shaft* (Inches (mm))
20DBBS	0.010 (0,25)	0.010 (0,25)
25DBBS	0.010 (0,25)	0.012 (0,30)
38DBBS	0.010 (0,25)	0.019 (0,48)
50DBBS	0.010 (0,25)	0.025 (0,64)

\*Perpendicularity measured near the O.D. of the mounting flange.

2.1.2 To aid in obtaining accurate readings, a rigid bracket should be fabricated for mounting a dial indicator when checking alignment.

2.1.3 Bearing or machinery manufacturers may require different alignment tolerances. Use the tightest of those recommended.

## 2.2 Mounting



### Warning

Support brackets for external stud support may be required for specific brake models. See Table 3 for models requiring support brackets. Consult Danfoss Airflex Engineering for design parameters.



### Warning

Failure to properly support studs as noted in Table 3 may result in drastic loss of torque, brake damage and brake failure.

TABLE 3  
Brake Sizes Requiring Rigid Support Bracket \*

No. of Discs	20DBBS	25DBBS	38DBBS	50DBBS
3				x
4	x	x	x	x

\* Customer must provide a RIGID support on the cylinder end of the brake. Consult Danfoss Airflex Engineering for design parameters.

2.2.1 Ensure that the shaft is clean and free of nicks or burrs and that the key fits properly in the shaft and gear. Tap the key into the shaft keyway.

2.2.2 On multiple disc brakes, before installing the gear onto the shaft, slide it into the brake assembly to align the splines on the discs. Air pressure must



### Warning

Maximum allowable air pressure is 120 psig (8.2 bar) for sizes 20DBBS, 25DBBS and 38DBBS. Maximum allowable air pressure is 150 psig (10.3 bar) for the 50DBBS. Application of pressure exceeding maximum allowable may result in damage to the brake.

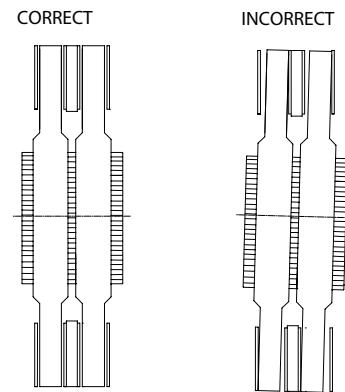

Figure 2

2.2.3 Apply a light coat of anti-seizing compound to the shaft.

2.2.4 To install the gear, heat uniformly to approximately 250°F (121°C), prior to pressing the gear onto the shaft. Making sure the dimension between the gear and brake mounting surface ("A") is held at 1.00" (25.4) for sizes 20DBBS, 25DBBS and 38DBBS and 2.00" for size 50DBBS. See Figure 1.



### Caution

Do not allow the gear temperature to exceed 350°F (176°C). Overheating the gear will adversely affect the hardness and wear life.

2.2.5 Apply a light coat of Castrol Molub-Alloy 936SF Heavy grease or equivalent to the gear teeth and slide the brake assembly onto the gear.

### Note

For reference, Danfoss Airflex part number for the specified grease is 000153X1182.

# DBBS Brakes

TABLE 4  
Fastener Description and Assembly Torque, lubed, ft.-lb. (Nm)

Item No. & Description	Specification	20DBBS	25DBBS*	38DBBS	50DBBS
18	Size	3/4-10NC-3	1-1/8 7NC-3	1-3/8 - 6NC3	1-3/8 - 6NC3
Self Locking Nut	Torque	150 (203)	500 (677)	750 (1015)	750 (1015)
20	Size	3/4 - 10NC-2 Gr. 8	1-1/8 - 7NC-2 Gr. 8	1-3/8 - 6NC-2 Gr. 8	1-3/8 - 6NC-2 Gr. 8
Hex Head Screw	Torque	150 (203)	500 (677)	750 (1015)	750 (1015)
Mounting Screw*	Size	5/8 - 11NC-2 Gr. 8	5/8 - 11NC-2 Gr. 8	1-8 NC-2 Gr. 8	1-3/8 - 6NC-2 Gr. 8
	Torque	170 (230)	170 (230)	680 (920)	1780 (2409)

\* The 325DBBS and the 425DBBS require larger mounting screws. The mounting screw required for both sizes is a 3/4"-10NC-2. Tightening torque is 280 lb-ft (380 Nm) lubed.

2.2.6 While supporting the brake, connect an air supply and apply enough pressure to release the brake. Attach the mounting flange (2) to the brake mounting surface using the appropriate fasteners. Torque the fasteners to the specified value. See Table 4.

#### Note

Mounting holes in the 325DBBS and 425DBBS brakes are larger than the 125DBBS and 225DBBS sizes. Be sure to use the correct size fasteners.



#### Danger

Use only the proper number and grade fasteners shown in Table 4. Use of commercial grade fasteners where Grade 8 fasteners are specified may result in failure of the fasteners and a sudden and drastic reduction in brake torque.

## 2.3 Air Supply System



#### Warning

Maximum allowable air pressure is 120 psig (8.2 bar) for sizes 20DBBS, 25DBBS and 38DBBS. Maximum allowable air pressure is 150 psig (10.3 bar) for the 50DBBS. Application of pressure exceeding maximum allowable may result in damage to the brake components.

2.3.1 Cylinder port size is 1/2"-14 NPT for sizes 20 and 25DBBS brakes, 3/4"-14 NPT for size 38DBBS brakes and 1"-11-1/2 NPT for size 50DBBS brakes.

2.3.2 Since the air control arrangement will vary from one application to the next, a specific description cannot be presented here. Following are some general guidelines for installing the air control components.

2.3.2.1 Use full size piping consistent with the control valve size. All piping should be free of metal chips, cutting compound, and any other foreign matter. Pipe ends should be reamed after cutting to eliminate possible restrictions.

2.3.2.2 Keep the number of elbows to a minimum to ensure consistent response.

2.3.2.3 Spool type solenoid valves are not recommended. Use poppet type valves and locate them as close as possible to the brake.



#### Warning

If the DBBS brake is being used on a mechanical power press, special valving may be required.

2.3.2.4 If the DBBS is being used on a cyclic application, an air receiver tank should be installed in the air supply line and isolated (check valve) from other air consuming equipment.

2.3.2.5 The final connection to the brake inlet ports must be made with flexible hose.

2.3.2.6 The DBBS brake does not require lubricated air; however the solenoid valve may. Consult the valve manufacturer.

2.3.2.7 A pressure switch should be located in the air supply line to the brake and interlocked with the equipment electrical controls.



#### Caution

Before modifying air supply lines, adding inline components or adding pressure switch interlocks, ensure brake will function in a safe manner.

# DBBS Brakes

## 3.0 Operation

### 3.1 Pressure and Speed Limits

3.1.1 Maximum allowable pressure is 120 psig (8.2 bar) for sizes 20DBBS, 25DBBS and 38DBBS. Maximum allowable air pressure is 150 psig (10.3 bar) for the 50DBBS.



#### Warning

Maximum applied pressure is 120 psig (8.2 bar) for sizes 20DBBS, 25DBBS and 38DBBS. Maximum allowable air pressure is 150 psig (10.3 bar) for the 50DBBS. Operation at pressures exceeding maximum may result in damage to the DBBS components.

3.1.2 Maximum freewheeling disc speeds are shown on Table 5.



#### Warning

Operation at disc speeds exceeding the maximum allowable, as shown on Table 5, may result in personal injury or product/equipment damage.

TABLE 5  
Maximum Disc Speeds

Size	Max. Free Wheeling Speed RPM
20DBBS	2200
25DBBS	1700
38DBBS	950
50DBBS	600

### 3.2 Initial Operation

#### 3.2.1 Wear-in/Burnishing

3.2.1.1 In order to improve initial operation and brake torque, it is suggested that the non-asbestos friction material used in the DBBS brakes be worn-in prior to normal operation to improve contact of the mating friction surfaces.



#### Caution

Machine operation should be monitored closely until the friction couple wears in.

3.2.1.2 The shaft on which the brake discs are mounted should be free to rotate to allow for run-in. On drawworks applications, disconnect the wire rope from the drawworks drum to allow operation as described in the following paragraphs.

TABLE 6  
DBBS Wear-in Parameters

Brake Size	Number of Discs	Slip Speed (rpm)	Brake Pressure psi (bar)	Slip Time (sec)	Maximum Free Wheeling Speed (rpm)	Maximum Temp at Start of Slip °F (°C)	Maximum Temp at End of Slip °F (°C)	Wear-in Cycles Required	Standard Quantity of Power Springs	Power Target HP (Kw)	Brake Torque Target in-lb (N-m)
20DBBS	1	120	60 (4.1)	60	2,200	120 (49)	250 (121)	15	18	29 (22)	15318 (1 730)
	2									58 (44)	30636 (3461)
	3									87 (65)	45954 (5192)
	4									116 (87)	61272 (6923)
25DBBS	1	120	65 (4.5)	60	1,700	120 (49)	250 (121)	15	24	52 (39)	27450 (3101)
	2									104 (78)	54900 (6202)
	3									156 (117)	82350 (9304)
	4									208 (156)	109800 (12405)
38DBBS	1	60	60 (4.1)	60	950	120 (49)	250 (121)	15	48	116 (87)	121848 (13 766)
	2									231 (173)	242646 (2 7415)
	3									347 (259)	364495 (41182)
	4									463 (346)	486343 (54949)
50DBBS	1	60	88 (6.1)	60	600	120 (49)	250 (121)	15	112	169 (120)	178000 (20111)
	2									338 (252)	356000 (40222)
	3									507 (378)	534000 (60333)
	4									676 (504)	712000 (80445)

# DBBS Brakes

- 3.2.1.3 Release the brake by applying full release pressure through the ports in the cylinder (19) to allow the brake to freely rotate.



## Caution

Maximum applied pressure is 120 psig (8.2 bar) for sizes 20DBBS, 25DBBS and 38DBBS. Maximum allowable air pressure is 150 psig (10.3 bar) for the 50DBBS. Minimum releasing pressure for low pressure brakes is 60 psig (4.1 bar).

- 3.2.1.4 Run the motor to achieve a brake disc speed listed in Table 6. Rapidly exhaust the air pressure in the brake to the pressure listed in Table 6. Slip the brake for the time specified in Table 6, but **DO NOT ALLOW THE BRAKE TO SLIP FOR MORE THAN THE TIME SPECIFIED.**



## Caution

Slipping the brake at increased time intervals, speeds, pressure or temperatures other than specified may result in damage to brake components.



## Caution

Brake pressures listed in Table 6 are for the standard compliment of power springs in the DBBS brake. The standard quantity is listed in Table 6. If a brake contains less than the standard compliment of springs, consult Danfoss/Airflex engineering for proper brake pressure to wear-in the brake and spring quantity if unknown for the specific brake.

- 3.2.1.5 After the brake has engaged/slipped for up to the maximum slip time specified in Table 6, quickly apply full air pressure to completely release the brake. Smoke rising from the brake should be expected. Freewheel the brake discs at speeds up to the maximum freewheeling speed in Table 6 to allow the brake discs to cool to a temperature at or below 120°F (49°C) use of fans or clean, dry compressed air can be used to accelerate the cooling process.



## Caution

Use proper safety precautions when using forced ventilation.

## Note

The brake pressure listed in Table 6 should provide a dynamic torque target value as listed and resultant power target at the brake speed listed. Since new friction torque will be lower at the start of wear-in procedure, pressure may need to be lowered to achieve the target torque. An adequate control and torque monitoring system must be used if pressure values less than those listed are used for wear-in. Target torque should be monitored to correspond to values listed.

- 3.2.1.6 Monitor the brake discs temperature during slipping and cooling. Do not allow the brake discs temperature to exceed 250°F (121°C).

- 3.2.1.7 Repeat steps 3.2.1.3 through 3.2.1.6 for the number of cycles shown in Table 6 to allow for adequate wear-in of the brake. Allow the brake disc to completely cool to ambient temperature prior to testing the torque capacity of the brake or returning it to service.

- 3.2.2 If the brake engagement appears harsh, a flow control valve may be installed in the brake air supply line. When using a flow control valve, install so free flow is to the brake and restricted flow is away from the brake.



## Caution

Excessive restriction of the brake exhaust air will result in long stopping times and inconsistent stopping position. Consult Danfoss Airflex Engineering with questions.

- 3.2.3 If the DBBS brake is used in combination with a clutch, clutch/brake overlap may occur which will result in excessive heat generation and motor overload. Overlap may be detected by monitoring the drive motor current at the beginning and end of each machine cycle. A current surge at the beginning of the cycle usually indicates clutch overlap which can be corrected by restricting the air flow to the clutch or increasing the air pressure to the brake. A current surge at the end of the machine cycle usually indicates brake overlap (see Figure 3) which can be corrected by installing and adjusting a flow control valve in the brake air supply line, as indicated in 3.2.2.

# DBBS Brakes

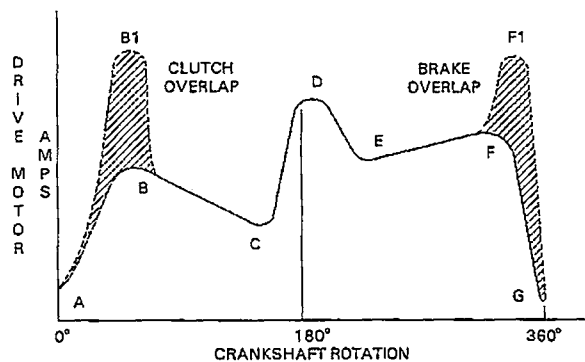

- A-B Normal Motor Amp Surge - During Acceleration
- A-B1 Abnormal Surge Indicates Clutch Overlap
- B-C Ram on Downstroke - Motor Amps Drop
- C-D Ampere Surge as Dies Make Contact
- E-F Ram Moving up Back Stroke
- F-G Clutch Release, Brake Set - Normal Drop to No Load Amps
- F-F1-G Ampere Surge Indicates Brake Overlap

Figure 3

## 3.3 Periodic Inspection

- 3.3.1 As the friction material wears, the brake torque will be reduced somewhat and adjustment of the stopping position controls (flow control or limit switch) will be necessary. See the Maintenance section for the friction material wear limit and replacement procedure.
- 3.3.2 Periodically inspect the brake for proper operation particularly if excessive heating of the disc (58) has been experienced or is suspected of having occurred. See 'WARNING' below. Excessive heating of brake components can be caused by disc dragging, excessive E-Stops, low air pressure, warping of the discs, or operating the brake beyond its designed capability.



### Warning

If the brake is subjected to heat, the discs (58) may shrink causing a condition whereby the discs will get stuck to the gear, limiting the axial movement. This condition will cause failure of the brake to develop full torque.



### Warning

Failure to develop full torque can cause drastic equipment failure, personal injury and/or death.

- 3.3.3 Periodically check for air leakage in the area of the piston seals (21, 23). For replacement, refer to the Maintenance section.
- 3.3.4 Periodically observe the discs with the brake

released. Causes of dragging discs may include wear or contamination of the gear or disc splines, disc imbalance, warped discs, or excessive shaft float.

3.3.5 Pneumatic and electrical control interlocks should be periodically checked for correct settings and operation.

3.3.6 Periodically remove the brass drain plug (105) and purge condensation from the cylinder. Replace the brass drain plug with sealant and check for air leaks.

## 4.0 Maintenance



### Warning

Prior to performing any maintenance on the DBBS brake, make sure the equipment is in, and will remain in, a safe condition. Never service a brake supporting a load.

## 4.1 Wear Limits

4.1.1 Wear limits for the DBBS components are shown on Table 7. If any wear limit has been reached or exceeded, that component must be repaired or replaced.

## 4.2 Wear Adjustment

### Note

Refer to Figure 4 for illustration of the friction material wear groove for the size 20DBBS, 25DBBS and 38DBBS brakes and friction material wear step in the size 50DBBS brakes. Refer to Figure 6, Figure 7, Figure 8 & Figure 9 for an illustration of the wear gaps on all DBBS sizes. On single and multiple disc units, the friction material must be replaced when worn to the bottom of the groove on the friction material or to the bottom of the step on the friction lining on the size 50 brakes. Multiple disc brakes, however, are manufactured with wear spacers that allow for wear adjustment when the 'Gap Required for Adjustment' has been reached per the values in Table 8. Typically, multiple disc brakes have a quantity of wear spacers equal to the number of discs minus 1. For example: a 450DBBS brake has 4 discs and 3 wear spacers. The exception to this rule is the 420DBBS that has additional 'thinner' spacers that will require four (4) adjustments. The number of wear spacers will dictate the number of adjustments before the brake requires complete disassembly for friction disc replacement. Spacers are removed to correct for wear. One set of spacers is removed for each wear adjustment.

# DBBS Brakes

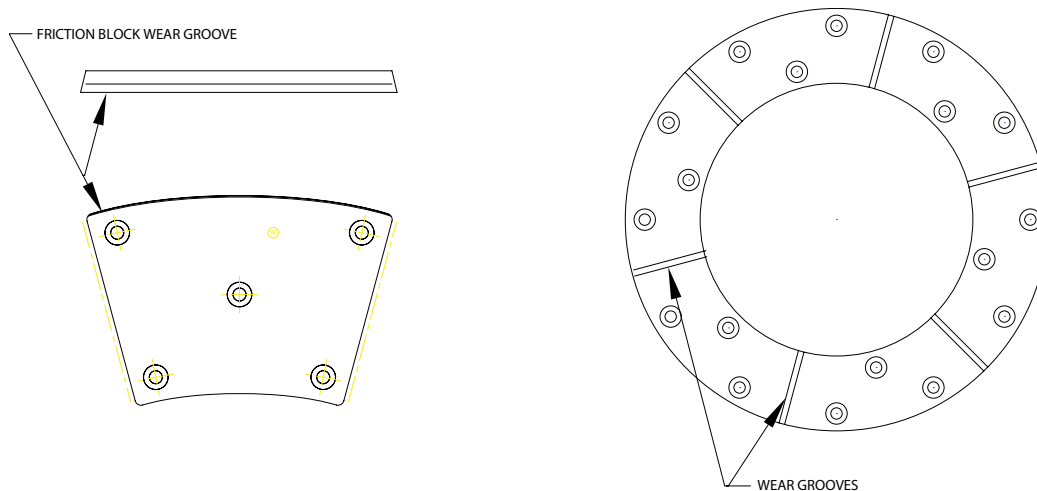

Figure 4

4.2.1 To determine when adjustment is required, make sure the brake is engaged then measure the gap between the spring housing (16) and the pressure plate (14) as shown in Figure 5. Measure the 'Y' gap between the pressure plate (14) and the reaction plate (31), the 'Y' gap between the reaction plate (31) and the mounting flange (2) and the 'Y' gap between the reaction plates (31) as shown in Figure 5, 6, 7, 8 and 9. If the measured gaps meet or be outside (larger or smaller) the limits shown on Table 8 AND none of the friction discs are worn to the bottom of the wear groove or the step on size 50 brakes, adjust the brake. It is also recommended to check the DBBS components for wear as shown in Table 7. If any wear limit has been reached or exceeded, that component must be repaired or replaced.



## Warning

If a wear adjustment is not made, the brake torque may deteriorate to the point where the equipment will not stop properly.



## Caution

Remove, retain or support discs as needed so that they do not fall off the gear during maintenance.

## Note

Prior to August 2012, multiple disc DBBS units were manufactured with solid wear spacers (29), requiring brakes to be fully disassembled in order to make wear adjustments. Multiple disc units manufactured from August 2012 and later, use the split wear spacers and adjustment can be conducted without full disassembly. Check the date code on your brake to verify the date of manufacture.

4.2.2 Wear Adjustment with Solid Wear Spacers

## Note

A Procedures for adjusting a two disc brake are listed below as an example.

4.2.2.1 Disconnect the air supply lines from the brake. Wipe down the brake and match mark all components from the mounting flange (2) to the cylinder (19) prior to disassembly. Match marking all components will ensure that the components are reinstalled in the orientation and location from which they were removed.

4.2.2.2 While supporting the cylinder (19), loosen the locknuts (18) ONE TURN AT A TIME and in an alternating (crosswise) pattern to prevent binding of the cylinder on the studs. Continue to loosen the locknuts until the force of the release springs (34) is relieved, allowing for access to the wear spacers (29). It may be necessary to push the reaction plate(s) (31) away from the mounting flange so that the release springs can be moved to gain access to the wear spacers.

## Note

Once the assembly is loose, the wear spacers (29) can be rotated to confirm that they are the 'Solid Wear Spacers' and the disassembly can proceed per 4.2.2.3 below. The split spacers are identified by the presence of a slot running across the thickness of the spacer. If the wear spacers have the slot, then they have been replaced with a split spacer kit and the DBBS can be adjusted without complete disassembly. See Section 4.2.3 for wear adjustment with split wear spacers. See figure 11 for an illustration of the split wear spacer.

# DBBS Brakes

TABLE 7  
Wear Limits for DBBS Components (Ref. Figs. 1 & 2 and Section 4.2)

Item	Description	Wear Limit	Remarks
#8 Friction Disc	Friction Material	Fully Worn at Bottom of dust groove. See Figure #4. Friction Material must also be replaced if contaminated with oil or grease.	Brake has adjustment provision See Section 4.2
#14 Pressure Plate and #31 Reaction Plate	Reaction Holes	Maximum wear is 0.031 in. (0.80 mm)	Wear will be in the form of elongation of the holes. Original hole diameters are shown on the table below
#12 Clamp Tube	Reaction Area	Maximum wear is 0.015 in. (0.38mm)	Wear will be in the form of notch or step on the side of tube.
#12Clamp Tube	Reaction Area	Maximum wear is 0.015 in. (0.38mm)	Wear will be in the form of notch or step on the side of tube.
#19 Cylinder	Seal Area	Maximum wear is 0.005 in. (0.13mm)	Wear will be in the form of grooves where the seals contact the cylinder wall.
#19 Cylinder	Seal Area	Maximum wear is 0.005 in. (0.13mm)	Wear will be in the form of grooves where the seals contact the cylinder wall.
#22, 34, & 52 Spring	Spring Free Height	Maximum free height shown on the table below.	Original free height shown on the table below. Springs must be replaced on complete sets.
#28 & 58 Gear & Disc	Gear Backlash	Maximum total backlash is 0.060 in. (1,5mm).	Backlash is measured at the pitch diameter. Replace the disc and gear together. If step is worn in gear, gear must be replaced.
#58 Disc	Friction Wear Surfaces	Maximum wear is 0.045 in. (1,12mm) per surface 0.090 in. (2,24mm) total	Original thickness for sizes 20 and 25 is 1.00 in (25,4mm), for size 38 and 50 it is 1.25 in. (31, 75mm). Wear will be in the form of circular grooves on the iron surface.

Item Reference	Description	Element Size			
		20DBBS	25DBBS	38DBBS	50DBBS
14 & 31	Original Reaction Hole Diameters in Pressure Plate and Reaction Plate	1.34 (34,11)	1.69 (42,9)	2.06 (54,4)	2.38 (60,33)
34	Original Free Height inch/(mm)	2.84 (72,1)	2.57 (65,3)	3.64 (92,4)	4.25 (108,0)
	Minimum Free Height inch/(mm)	2.65 (67,3)	2.40 (61,0)	3.40 (86,4)	4.12 (104, 7)
22	Original Free Height inch/(mm)	4.56 (115,8)	5.18 (131,6)	6.65 (168,9)	9.00 (228,6)
	Minimum Free Height inch/(mm)	4.25 (108,0)	4.90 (125,5)	6.37 (161,8)	8.75 (222,3)
52	Original Free Height inch/(mm)	n/a	5.23 (132,8)	6.78 (172,2)	n/a
	Minimum Free Height inch/(mm)	n/a	4.95 (125, 7)	6.50 (165,1)	n/a

# DBBS Brakes

TABLE 8  
Wear Gap Values, - Inches (mm)

Disc Size Inches	Qty. of Discs	*X-Gap New Gap inch (mm)	(X-Gap) Gap Required for Adjustment inch (mm)	Y-Gap New Gap inch (mm)	(Y-Gap) gap required for Adjustment inch (mm)
20DBBS	1	-	-	-	-
	2	0.14 (3,6)	0.64 (16,3)	2.14(54,4)	1.64 (41, 7)
	3	0.21 (5,3)	0.71 (18,0)	2.14 (54,4)	1.64 (41, 7)
	4	0.28 ( 7,1)	0.66 (16,6)	2.14 (54,4)	1.64 (41, 7)
25DBBS	1	-	-	-	-
	2	0.18 (4,6)	0.68 (1 7,3)	2.14(54,4)	1.64 (41, 7)
	3	0.27 (6,8)	0.77 (19,5)	2.14 (54,4)	1.64 (41, 7)
	4	0.36 (9,1)	0.86 (21,8)	2.14 (54,4)	1.64 (41, 7)
38DBBS	1	-	-	-	-
	2	0.23 (5,9)	0.65 (16,5)	2.39 (60, 7)	1.97 (50,1)
	3	0.30 ( 7,6)	0.72 (18,2)	2.39 (60, 7)	1.97 (50,1)
	4	0.40 (10,1)	0.82 (20,8)	2.39 (60, 7)	1.97 (50,1)
50DBBS	1	-	-	-	-
	2	0.31 ( 7,9)	0.732 (18,6)	2.39 (60, 7)	1.97 (50,1)
	3	0.47 (11,9)	0.888 (22,5)	2.39 (60, 7)	1.97 (50,1)
	4	0.62(15,8)	1.044 (26,5)	2.39 (60, 7)	1.97 (50,1)

\* Value shown is GAP after wear adjustment. New or rebuilt brakes may vary slightly from this value due to tolerances.

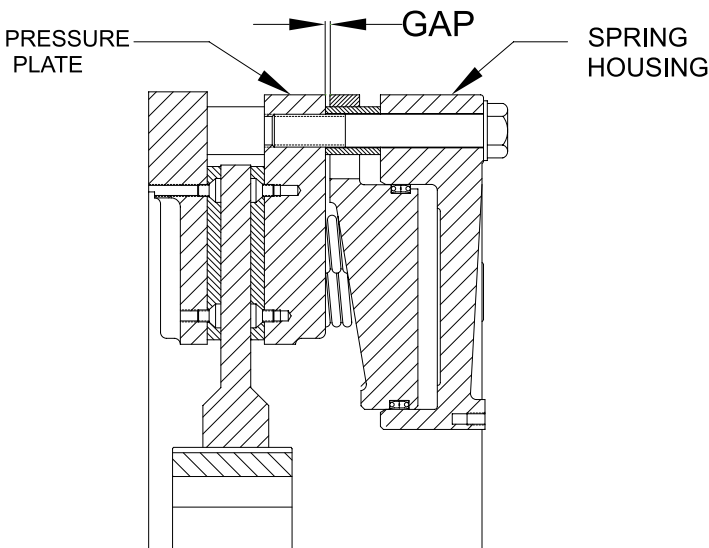

Figure 5

4.2.2.3 Remove the locknuts (18) and washers (1 7) and slide the cylinder (19), spring housing (16) and pressure plate (14) off of the studs (6) as an assembly. Set aside in a clean area making sure not to damage the friction disc (8) or friction block on size 50 brake, on the pressure plate. See TABLE 9 for weight of sub assembly.

TABLE 9  
POWER HEAD WEIGHTS

Brake Size	Approximate Total Weight Lbs (kg)
20DBBS	271 (59 7)
25DBBS	543 (1195)
38DBBS	1585 (348 7)
50DBBS	3994 (8 787)

**Note**

If a stud (6) should happen to come loose, remove it completely and clean the threads on the stud and the threads in the mounting flange. Apply Loctite ® Loc-Quic ® Primer Grade "T" to the stud threads. After the threads have dried, assemble to the mounting flange using Loctite #262. The end of the stud must not extend past the mounting surface on the mounting flange.



**CAUTION**

The locknuts (18) must be loosened gradually to prevent damage to the brake components.

# DBBS Brakes

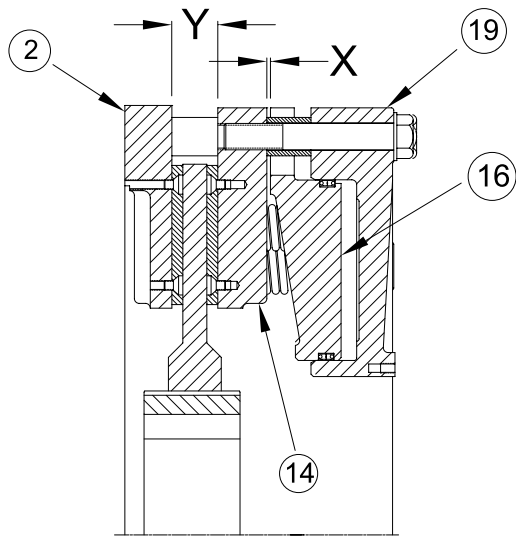

Figure 6

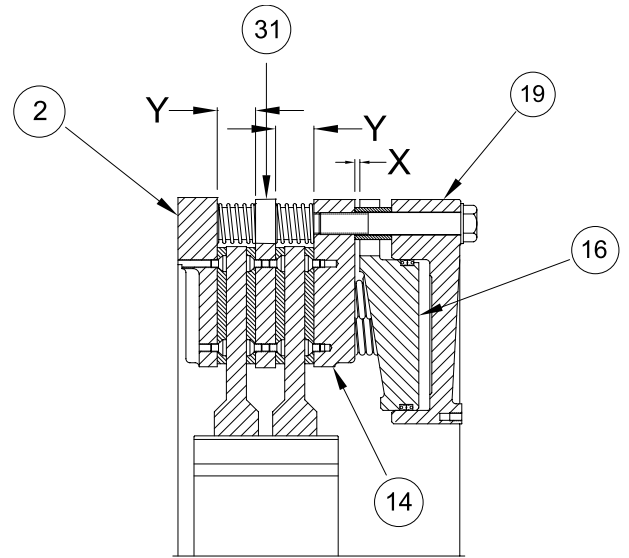

Figure 7

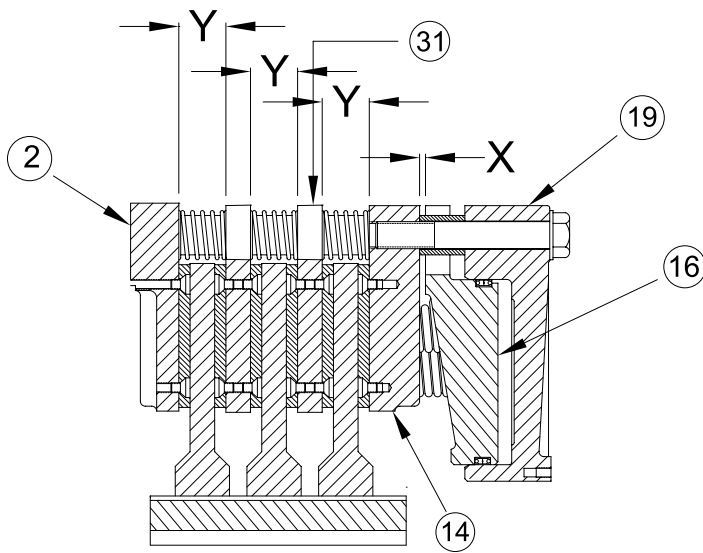

Figure 8

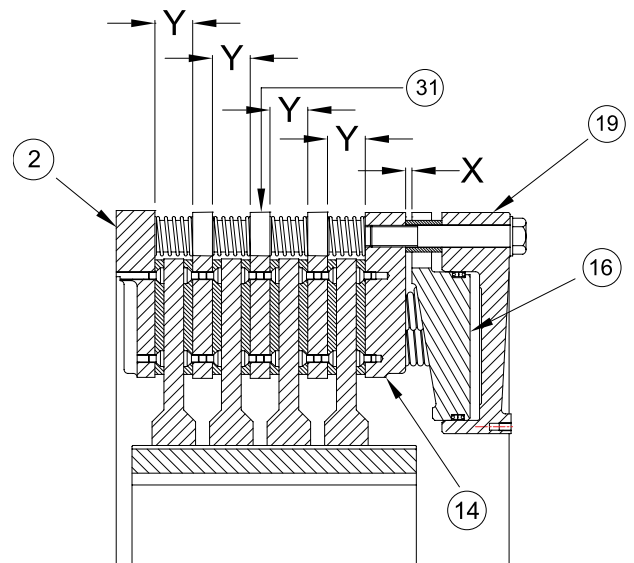

Figure 9

# DBBS Brakes



## Caution

Loctite#262 must be shaken prior to application.



## Caution

Loctite #262 may irritate sensitive skin. Refer to the product label for safety precautions.

- 4.2.2.4 Remove the outboard disc (58), the reaction plate (31) and the release springs (34) and set aside.

## Note

For 3 disc brakes remove one additional disc, reaction plate and set of springs during disassembly.

## Note

For 4 disc brakes remove two additional disc, reaction plate and set of springs during disassembly.

- 4.2.2.5 Slide the clamp tubes (12) and one set (layer) of wear spacers (29) off of the studs. Reinstall the clamp tubes only. For all sizes of DBBS brakes clamp tubes (12) are placed over every stud (6).

- 4.2.2.6 Place the release springs (34) onto the clamp tubes (12) and slide the reaction plate (31) onto the clamp tubes.

## Note

For 2,3 & 4 disc brakes, sizes 20, 25 & 38 DBBS, release springs (12) are equally spaced on 4 clamp tubes.

## Note

For 2,3 & 4 disc brakes, size 50DBBS, release springs (12) are placed on every clamp tube.

- 4.2.2.7 Slide the second disc onto the gear.

- 4.2.2.8 Place the release springs (34) onto the clamp tube (12) and slide the pressure plate/cylinder assembly onto the clamp tubes.

- 4.2.2.9 Lubricate the threads on the ends of the studs with 30 wt. oil or anti-seizing compound and install the locknuts (18), washers (17) and the wear spacers (29) removed in 4.2.2.5. The wear spacers are "stored" under the locknuts for use after replacing friction discs (8). See Figure 10.

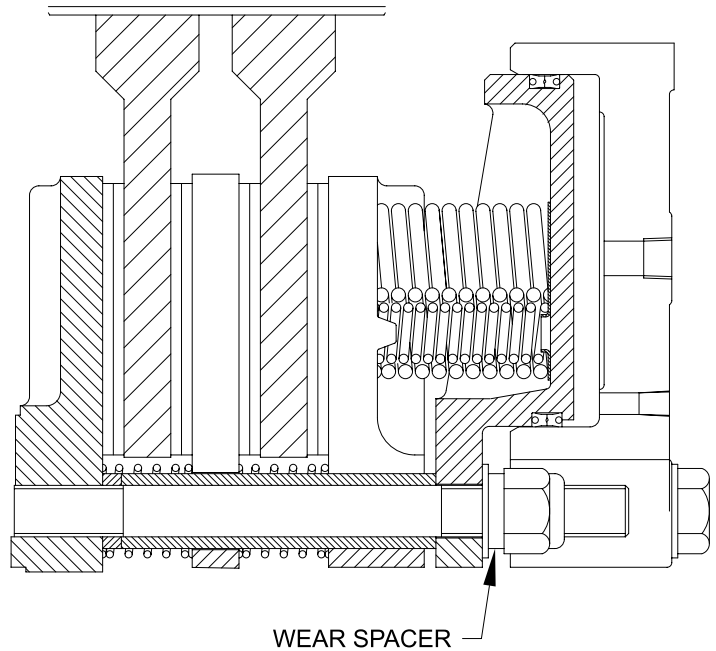

Figure 10

## Note

It is recommended to dispose of the solid wear spacers and use split spacers when replacing the friction discs.

- 4.2.2.10 While supporting the weight of the cylinder/spring housing/pressure plate assembly, tighten the locknuts (18), ONE TURN AT A TIME and in a crosswise pattern, until the spring housing is seated against the clamp tubes. Torque the locknuts to the appropriate value. See Table 4.



## Caution

The locknuts (18) must be tightened gradually to prevent damage to the brake components.

- 4.2.3 Wear Adjustment with Split Wear Spacers

## Note

To determine the type of wear spacers (29) installed in the brake, refer to section 4.2.3.4 that directs to loosen the locknuts (18) until the force of the release springs is relieved. Once the assembly is loose, the wear spacers can be rotated to confirm that they are the 'Split Spacers'. The split wear spacers are identified by the presence of a slot running across the thickness of the spacer. If the wear spacers do

# DBBS Brakes

not have the slot then they are solid wear spacers and the DBBS must be disassembled per 4.2.2 in order to make adjustments.



## Caution

Be sure to follow 4.2.3.4 instructions complete to prevent damage to the brake components

4.2.3.1 Disconnect the air supply lines from the brake. Wipe down the brake and match mark all components from the mounting flange (2) to the cylinder (19) prior to disassembly. Match marking all components will ensure that the components are reinstalled in the orientation and location from which they were removed.

4.2.3.2 Wear adjustment can be conducted without full disassembly of the Multi-disc DBBS brake. The wear adjustment spacers are slotted to allow for easy removal with a chisel. See Figure 11.

4.2.3.3 Wear spacers shall be removed in complete sets only (one from each stud location). Mark the spacers to be removed to avoid confusion during removal.



## Warning

Removal of spacers in quantities other than complete sets (layers) will result in severe damage to DBBS components during reassembly and could cause the brake to not function properly.

4.2.3.4 Loosen the locknuts (18) one at a time and in an alternating (crosswise) pattern to prevent binding of the cylinder on the studs. Continue to loosen the locknuts until the force of the release springs is relieved, allowing for access to the wear spacers. It may be necessary to push the reaction plate(s) away from the mounting flange so that the release springs can be moved to gain access to the wear spacers.



## Caution

The locknuts (18) must be loosened gradually to prevent damage to the brake components.



## Caution

Remove discs as needed so that they do not fall off the gear during maintenance.

4.2.3.5 Using a narrow chisel wedged into the slot in the wear spacer, pry the wear spacer until it fractures and is clear to be removed from the stud. Repeat for the remaining spacers in the set that is to be removed (one spacer from each stud position). See Fig 11.

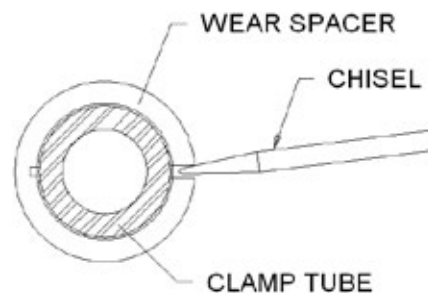

Figure 11

## Removing Split Wear Spacers with Chisel



## Warning

Be sure to collect all wear spacers when removed. Spacers lodging in between brake components could prevent the brake from properly engaging or releasing.

4.2.3.6 While supporting the weight of the cylinder/piston assembly, tighten the locknuts (18) ONE TURN AT A TIME and in a crosswise pattern until the cylinder is seated firmly against the clamp tubes. Torque the locknuts to the appropriate value. See Table 4.



## Caution

The locknuts (18) must be tightened gradually and evenly to prevent damage to the brake components.

4.2.3.7 Restore any piping or covers removed prior to operating the brake.

## 4.3 Friction Disc Replacement



## Caution

Use only genuine, Airflex friction material. Use of material not of Airflex origin may result in unpredictable brake performance and/or excessive wear of the brake components.

# DBBS Brakes

Friction disc replacement is required when the friction material is worn to the bottom of the wear groove or step for size 50 brake, as indicated in Figure 4, or if oil or grease has contaminated the surface. In Figure 4 note the location of the wear grooves on the friction disc on sizes 20, 25 & 38 versus the step on the edge of the friction block for size 50 brakes.

- 4.3.1 Reference section 6.3 for Friction Disc Kit part numbers.
- 4.3.2 Disconnect the air supply lines from the brake.
- 4.3.3 Remove the brake and place it on a level working surface, with the mounting flange facing down.
- 4.3.4 Loosen the locknuts (18) ONE TURN AT A TIME and in an alternating (crosswise) pattern until the spring force is relieved. Remove the locknuts, washers (1 and wear spacers (if stored). 7)



#### Caution

The locknuts (18) must be loosened gradually to prevent damage to the brake components.



#### Caution

Refer to Table 9 for power head weights before lifting the power head. Provide properly rated lifting devices. Failure to use the properly sized and rated lifting devices can cause equipment damage and personal injury.

#### Note

The term 'power head' refers to the subassembly consisting of the spring housing, cylinder, and pressure plate.

- 4.3.5 Lift the cylinder, spring housing, and pressure plate off of the studs as an assembly. Set the assembly aside on a level working surface, with the cylinder facing down.

#### Note

If a stud (6) should happen to come loose, remove it completely and clean the threads on the stud and the threads in the mounting flange. Apply Loctite Primer Grade "T" to the stud Threads. After the threads

have dried, assemble to the mounting flange using Loctite #262. The end of the stud must not extend past the mounting surface on the mounting flange.



#### Caution

Loctite #262 must be shaken prior to application.



#### Caution

Loctite #262 may irritate sensitive skin. Refer to the product label for safety precautions.

- 4.3.6 On multiple disc brakes, remove the reaction plate (31), release springs (34), clamp tubes (12) and the remaining disc(s)(58).
- 4.3.7 Inspect the brake components for wear or damage. Replace as required. For wear limits of components, see Table 7.
- 4.3.8 Remove the socket head screws and friction discs or blocks and discard.

#### Note

It may be necessary to use heat to soften the Loctite to ease screw removal. Use a pinpoint torch, heating only the socket area of the screw.

- 4.3.9 Smooth the friction mounting surfaces of any burrs or raised areas with a course, flat polishing stone, and clean the tapped holes of any residual Loctite or other contamination. Check screw fit and chase the threads if necessary being sure to final clean the tapped holes of any residual contamination.



#### Caution

Before installing screws, make sure that the screw threads and threaded holes are clean to ensure that the new screws will lock properly.

- 4.3.10 Position the new friction discs (friction blocks on the 50DBBS) on the mounting surfaces. Apply Loctite #262 to the threads of the screws (5 7), install and torque the screws to 20 ft.-lb.



#### Caution

Loctite #262 must be shaken prior to application.

# DBBS Brakes



## Caution

Loctite #262 may irritate sensitive skin. Refer to the product label for safety precautions.

## Note

When replacing friction material, it is suggested that discs (58) also be replaced to ensure good surface contact.

- 4.3.11 Position a disc (58) on the mounting flange/friction disc assembly. Center the disc on the friction material.
- 4.3.12 On multiple disc units, install wear spacers (29), clamp tubes (12), release springs (34), the reaction plate, and remaining reaction springs over the studs. Position the remaining disc (58) on the reaction plate/friction disc assembly. Center the disc on the friction material and align the disc splines with those on the first disc.

## Note

It is suggested that the Wear Spacers (29) be the Split Wear Spacer type.

- 4.3.12.1 Wear Spacers (29) are installed in sets onto each stud. The number of wear spacers must be equal on each stud.
- 4.3.12.2 Clamp tubes (12) are installed onto each stud and rest upon the wear spacers (29).
- 4.3.12.3 Release springs (34) are installed over the clamp tubes (12) as outlined in Section 4.2.2.6



## Caution

The position of the release springs can vary with different brake sizes. If unsure of assembly position, consult Danfoss Airflex Engineering. The springs on either side of the reaction plate must be assembled on the same stud, over the clamp tubes. Improper assembly will result in cocking of the reaction plate and uneven brake release. Refer to section 4.2 and 6.1 for wear spacer quantity.

- 4.3.13 Lubricate the threads on the ends of the studs with 30 wt. oil or Never Seez<sup>®</sup> anti-seizing compound.

- 4.3.14 Hoist the cylinder, spring housing and pressure plate assembly into position. Noting the position of the air inlets to the mounting flange, lower the assembly over the studs and clamp tubes.

- 4.3.15 Assemble the washers (1-7) and locknuts (18) onto the studs. Tighten the locknuts, ONE TURN AT A TIME and in a crosswise pattern, until the spring housing is seated against the clamp tubes. Torque the locknuts to the appropriate value. See Table 4.



## Caution

The locknuts (18) must be tightened gradually to prevent damage to the brake components.

- 4.3.16 Re-install the brake per 2.0, 'Installation'.

## 4.4 Cylinder Seal Replacement

- 4.4.1 Reference section 6.2 for Cylinder Seal Kit part numbers.

- 4.4.2 Disconnect the air supply lines and remove the screws (20), washers (1-7) and spacer tubes (2-7) attaching the cylinder (19) to the pressure plate (14).

- 4.4.3 Carefully slide the cylinder (19) off of the spring housing (16).



## Caution

Do not use compressed air to remove the cylinder (19) from the spring housing.

- 4.4.4 Remove the cylinder seals (21, 23) from the spring housing (16) and thoroughly clean the seal grooves in the spring housing.

- 4.4.5 Insert new seals (21) (23) into the grooves, noting the orientation of the seals per Figure 12.

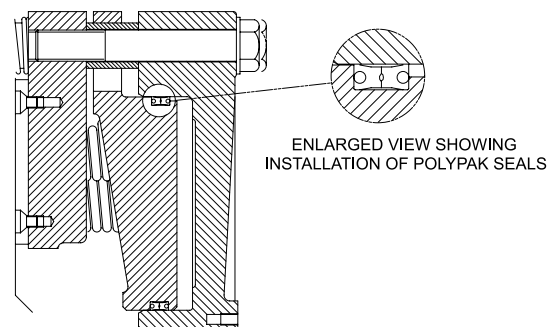

Figure 12

# DBBS Brakes

4.4.6 Carefully examine the seal surfaces in the cylinder (19). If the surfaces have worn to the point as indicated on Table 7, the cylinder must be replaced.

4.4.7 Lubricate the seal surfaces in the cylinder (19) with Molykote<sup>®</sup> 55M Grease and carefully slide the cylinder onto the spring housing (16). Take special care to avoid damaging the seal lips.

4.4.8 Attach the cylinder (19) to the pressure plate (14) with the screws (20), washers (1-7) and spacer tubes (27) removed in 4.4.2. Use Loctite Loc-Quic Primer Grade "T" to clean and prepare the screw threads and install with Loctite #262. Using a crosswise pattern, torque the screws to the value shown on Table 4.



#### Caution

Loctite #262 must be shaken prior to application.



#### Caution

Loctite #262 may irritate sensitive skin. Refer to the product label for safety precautions.

## 4.5 Spring Replacement

### 4.5.1 Spring Replacement for 20 DBBS & 25 DBBS Brakes

#### Warning

Make sure that the machinery and related loads are properly secured or supported to prevent shaft rotation prior to releasing, removing or performing maintenance on the DBBS brake assembly.

4.5.1.1 Disconnect the air supply lines and loosen the locknuts (18), ONE TURN AT A TIME and in a crosswise pattern, until the spring force has been relieved.

4.5.1.2 Match mark the pressure plate and spring housing to one another.

4.5.1.3 Remove the locknuts (18) and washers (1-7) and carefully remove the cylinder/spring housing/pressure plate assembly. Transport to a clean work area.



#### Caution

The locknuts (18) must be loosened gradually to prevent damage to the brake components.

4.5.1.4 Loosen the screws (20) gradually ONE TURN AT A TIME, following a crosswise pattern until the remaining spring force is relieved. Remove the screws and washers (17).

4.5.1.5 Carefully lift the cylinder and spring housing off of the pressure plate, exposing the springs (22).

#### Note

If the cylinder (20) is removed from the spring housing (16), refer to Section 4.4 for inspection of the seals, replacement (if necessary) and reassembly of the cylinder/spring housing/pressure plate assembly.

#### Note

Before removing the old springs, make note of the number used and the position that they are in so that the new springs may be installed similarly for proper brake functioning.

4.5.1.6 Noting their orientation, remove the spring retainer plates (53), exposing the springs.

4.5.1.7 Remove the springs and check the free height. If the free height of any spring is less than the value shown on Table 7, or any springs are cracked or broken, the entire complement of springs must be replaced.

4.5.1.8 Re-install the springs into the pockets in the pressure plate.



#### Caution

No spring retainer plate (53) should cross over the ribs in the spring housing (16).

4.5.1.9 Place a spacer tube (2-7) in position over each tapped hole in the pressure plate (14), align the match marks and carefully lower the spring housing/cylinder assembly onto the springs, making sure the springs engage the bosses in the spring housing.

4.5.1.10 Clean the threads on the hex head screws (20) and install the hex head screws and flat washers (1-7). Using a crosswise pattern, tighten the screws one turn at a time until the spacer tubes are clamped between the cylinder and pressure plate.

4.5.1.11 Remove the hex head screws (20) one at a time. Clean and prepare the screw threads and apply Loctite LocQuic<sup>®</sup> Primer "T" to the screw threads.

# DBBS Brakes

Apply Loctite #262 to the screw threads and reinstall the hex head screw. Immediately torque the hex head screw to the value shown on Table 4.

## Note

When removing and reinstalling the hex head screw (20), spray the cleaned bolt threads with Locquic Primer "T". Let parts dry and then apply Loctite #262 on the same surface. Install the hex head screw and immediately torque as stated in 4.5.2.11.



## Warning

Loctite #262 may cure prior to properly tightening the hex head screw (20) if not tightened to the proper torque value immediately after installation.



## Caution

Loctite #262 must be shaken prior to application.



## Caution

Loctite #262 may irritate sensitive skin. Refer to the product label for safety precautions.

4.5.1.12 Hoist the cylinder/spring housing/pressure plate subassembly into position and align the holes in the spring housing with the studs and slide the assembly until it is positioned against the face of the disc. Assemble a flat washer and locknut on each stud, tightening until it just begins to make contact with the spring housing.

4.5.1.13 While supporting the weight of the cylinder/spring housing/pressure plate assembly, tighten the locknuts, ONE TURN AT A TIME and in a crosswise pattern, until the spring housing is seated against the clamp tubes. Torque the locknuts to the appropriate value. See Table 4.



## Caution

The locknuts (18) must be tightened gradually to prevent damage to the brake components.

4.5.2 Spring Replacement for 38 DBBS & 50 DBBS Brakes



## Warning

Make sure that the machinery and related loads are properly secured or supported to prevent shaft rotation prior to releasing, removing or performing maintenance on the DBBS brake assembly.

4.5.2.1 Disconnect the air supply lines from the brake.

4.5.2.2 Remove the fasteners that secure the brake and support brackets (if applicable) to the mounting structure

4.5.2.3 Using soft slings, rig the brake and slide the brake off of the gear. Avoid placing slings or straps directly on the release springs (34).

4.5.2.4 Transport the brake to a clean working area and position the assembly on a flat surface with the mounting flange (2) facing down.

4.5.2.5 Wipe the brake clean of oils, dirt and grease or other contamination.

4.5.2.6 Match-mark the mounting flange (2), reaction plate(s) (31), pressure plate (14), spring housing (16) and cylinder (19) to one another prior to disassembly to adequately show the proper orientation of components to one another.

4.5.2.7 With the brake still fully assembled and the cylinder (19) facing up, loosen the hex head screws (20) ONE TURN AT A TIME, following a crosswise sequence. Remove the hex head screws and washers (1 7).



## Caution

Failure to loosen the screws (20) evenly and in small increments as described may cause the screws or cylinder (19) to bind.

4.5.2.8 Loosen the locknuts (18) –ONE TURN AT A TIME– and in sequence until the spring force is relieved.

4.5.2.9 Carefully lift the spring housing (16) and cylinder (19) subassembly off of the studs to expose the springs (22) (52) and spring retainers (53). Note the locations of the springs and spring retainers for reassembly purposes.

## Note

If the cylinder (20) is removed from the spring housing (16), refer to Section 4.4 for inspection of the seals, replacement (if necessary) and reassembly of the cylinder/spring housing assembly.



## Caution

Before removing the old springs (22) (52), make note of the number used and the position that they are in

# DBBS Brakes

so that the new springs may be installed similarly for proper brake functioning.

4.5.2.10 Inspect the springs (22) (52) for distortion and check the free height. If the free height of any spring is less than the value shown on Table 7, the entire set of springs must be replaced.

4.5.2.11 Install the springs (22) (52) in a symmetrical pattern on the pressure plate (16) distributing them as evenly as possible. Locate the springs over bosses or in the spring pockets in the pressure plate (14). If applicable, position the spring retainers (53) on top of the springs to hold the springs into position.

## Note

If unknown, contact the factory for specific information showing locations of springs and spring retainers for your specific brake configuration.



## Warning

Loctite may cure prior to properly tightening the hex head screw (20) if not tightened to the proper torque value immediately after installation.



## Caution

Loctite #262 must be shaken prior to application.



## Caution

Loctite #262 may irritate sensitive skin. Refer to the product label for safety precautions.



## Caution

No spring retainer (53) should cross over the ribs in the spring housing (16).

4.5.2.12 Aligning match-marks, carefully lower the spring housing and cylinder subassembly (16) (19) onto the springs (22) (52) and spring retainers (53), making sure the springs engage the bosses in the spring housing if applicable.

4.5.2.13 Lubricate the ends of the studs (6) with a 30 weight oil or an anti-seize compound, and assemble the flat washers (1 7) and locknuts (18) onto the studs. Tighten the nuts in an even crosswise pattern –ONE TURN AT A TIME- to evenly compress the springs. Tighten the nuts to the final tightening torque listed in Table 4.



## Caution

The locknuts (18) must be tightened gradually to prevent damage to the brake components.

4.5.2.14 Position the spacer tubes (2 7) in-line with the bolt holes of the cylinder and install the hex head screws (20) and lock washers (17). Tighten the screws in a crosswise pattern –ONE TURN AT A TIME- until the spacer tubes are clamped between the cylinder (19) and the pressure plate (16).

4.5.2.15 Remove the hex head screws (20) one at a time. Clean and prepare the screw threads and apply Loctite Locquic Primer "T" to the screw threads. Apply Loctite #262 to the screw threads and reinstall

the hex head screw. Immediately torque the hex head screw to the value shown on Table 4.

## Note

When removing and reinstalling the hex head screw (20), spray the cleaned bolt threads with Locquic Primer "T". Let parts dry and then apply Loctite #262 on the same surface. Install the hex head screw and immediately torque as stated in 4.5.2.15.

5.0 Ordering Information/Technical Assistance

5.1 Equipment Reference

5.1.1 In any correspondence regarding Danfoss Airflex Equipment, refer to the information on the product nameplate and call or write:

**Danfoss  
Power Solutions (US) Company**  
2800 East 13th Street  
Ames, IA 50010, USA  
Phone:+1 515 239 6000

Loctite and Loc-Quic are registered trademarks of Henkel Corporation.

Never-Seez is a registered trademark of Snap-On Tool Corporation.

Castrol Molub-Alloy 936SF Heavy is a registered trademark of Castrol Limited.

Molykote is a registered trademark of Dow Corning Corp.

# DBBS Brakes

## 6.0 PARTS LISTS

### 6.1 Basic Assemblies

Item	Description	120DBBS 146323A		220DBBS 146322A		320DBBS 146373A		420DBBS 146374A	
		Part Number	Qty	Part Number	Qty	Part Number	Qty	Part Number	Qty
2	Mounting Flange	513331	1	513331	1	513331	1	513331	1
6	Stud	000245 x 0066	12	000245 x 0063	12	000245 x 0083	12	000245 x 0098	12
8	Friction Disc	513326	2	513326	4	513326	6	513326	8
12	Clamp Tube	306956-14	12	306956-15	12	306956-28	12	306956-29	12
14	Pressure Plate	513332	1	513332	1	513332	1	513332	1
16	Spring Housing	512639	1	512639	1	512639	1	512639	1
17	Flat Washer	000153 x 0 727	24	000153 x 0 727	24	000153 x 0 727	24	000153 x 0 727	24
18	Locknut	000110 x 0030	12	000110 x 0030	12	000110 x 0030	12	000110 x 0030	12
19	Cylinder	512693	1	512693	1	512693	1	512693	1
20	Hex Head Screw	000197 x 0 723	12	000197 x 0 723	12	000197 x 0 723	12	000197 x 0 723	12
21	Inner Lip Seal	000402 x 0021	2	000402 x 0021	2	000402 x 0021	2	000402 x 0021	2
22	Outer Spring	307947	18	307947	18	307947	18	307947	18
23	Outer Lip Seal	000402 x 0022	2	000402 x 0022	2	000402 x 0022	2	000402 x 0022	2
27	Spacer Tube	308155-06	12	308155-06	12	308155-06	12	308155-06	12
28	Gear (not included with assembly)	415900-####	1	416059-####	1	416471-####	1	416472-####	1
29	Wear Spacer	N/A	N/A	308155-02	12	308155-02	24	308155-04	48
31	Reaction Plate	N/A	N/A	513330	1	513330	2	513330	3
34	Release Spring	N/A	N/A	307629	6	307629	9	307629	12
52	Inner Spring	N/A	N/A	N/A	N/A	N/A	N/A	N/A	N/A
53	Spring Retainer	415823	6	415823	6	415823	6	415823	6
57	Flat Head Screw	000294 x 0405	36	000294 x 0405	72	000294 x 0405	108	000294 x 0405	144
58	Disc	513328	1	513328	2	513328	3	513326	4
105	Brass Pipe Plug	000077 x 0021	1	000077 x 0021	1	000077 x 0021	1	000077 x 0021	1

Item	Description	125DBBS 146320A		225DBBS 146330A		325DBBS 146382A		425DBBS 146383A	
		Part Number	Qty	Part Number	Qty	Part Number	Qty	Part Number	Qty
2	Mounting Flange	513334	1	513334	1	514198	1	514198	1
6	Stud	000245 x 0068	12	000245 x 00 77	12	000245 x 008 7	12	000245 x 0094	12
8	Friction Disc	513307	2	513307	4	513307	6	513307	8
12	Clamp Tube	306542-1 7	12	306542-18	12	306542-3 7	12	306542-36	12
14	Pressure Plate	513335	1	513335	1	513335	1	513335	1
16	Spring Housing	513268	1	513268	1	513268	1	513268	1
17	Flat Washer	000153 x 0641	24	000153 x 0641	24	000153 x 0641	24	000153 x 0641	24
18	Locknut	000110 x 00 73	12	000110 x 00 73	12	000110 x 00 73	12	000110 x 00 73	12
19	Cylinder	513264	1	513264	1	513264	1	513264	1
20	Hex Head Screw	000197 x 1035	12	000197 x 1035	12	000197 x 1035	12	000197 x 1035	12
21	Inner Lip Seal	000402 x 0023	2	000402 x 0023	2	000402 x 0023	2	000402 x 0023	2
22	Outer Spring	307970	24	307970	24	307970	24	307970	24
23	Outer Lip Seal	000402 x 0024	2	000402 x 0024	2	000402 x 0024	2	000402 x 0024	2
27	Spacer Tube	308170-02	12	308170-02	12	308170-02	12	308170-02	12
28	Gear (not included with assembly)	416073-####	1	416074-####	1	416477-####	1	416470-####	1
29	Wear Spacer	N/A	N/A	308170-01	12	308170-01	24	308170-01	36
31	Reaction Plate	N/A	N/A	513333	1	513333	2	513333	3
34	Release Spring	N/A	N/A	306909	6	306909	9	306909	12
52	Inner Spring	307969	24	307969	24	307969	24	307969	24
53	Spring Retainer	307971	12	307971	12	307971	12	307971	12
57	Flat Head Screw	000294 x 0405	48	000294 x 0405	96	000294 x 0405	144	000294 x 0405	192
57	Disc	513304	1	513304	2	513304	3	513304	4
105	Brass Pipe Plug	000077 x 0021	1	000077 x 0021	1	000077 x 0021	1	000077 x 0021	1

# DBBS Brakes

Item	Description	138DBBS 146328A		238DBBS 146329A		338DBBS 146384A		438DBBS 146385A	
		Part Number	Qty	Part Number	Qty	Part Number	Qty	Part Number	Qty
2	Mounting Flange	513391	1	513391	1	513391	1	513391	1
6	Stud	000245 x 00 73	16	000245 x 00 75	16	000245 x 0106	16	000245 x 0105	16
8	Friction Disc	513396	2	513396	4	513396	6	513396	8
12	Clamp Tube	307941-03	16	307941-04	16	307941-11	16	307941-10	16
14	Pressure Plate	513392	1	513392	1	513392	1	513392	1
16	Spring Housing	512811	1	512811	1	513764	1	513764	1
17	Flat Washer	00006 7 x 0042	32	00006 7 x 0042	32	00006 7 x 0042	32	00006 7 x 0042	32
18	Locknut	000110 x 00 75	16	000110 x 00 75	16	000110 x 00 75	16	000110 x 00 75	16
19	Cylinder	513988	1	513988	1	513988	1	513988	1
20	Hex Head Screw	00019 7 x 1338	16	00019 7 x 1338	16	00019 7 x 1338	16	00019 7 x 1338	16
21	Inner Lip Seal	000402 x 0005	2	000402 x 0005	2	000402 x 0005	2	000402 x 0005	2
22	Outer Spring	308035	48	308035	48	308035	48	308035	48
23	Outer Lip Seal	000402 x 0006	2	000402 x 0006	2	000402 x 0006	2	000402 x 0006	2
27	Spacer Tube	308150-01	16	308150-01	16	308150-01	16	308150-01	16
28	Gear (not included with assembly)	416068-####	1	416069-####	1	416414-####	1	416461-####	1
29	Wear Spacer	N/A	N/A	308150-05	16	308150-05	32	308150-05	48
31	Reaction Plate	N/A	N/A	513393	1	513393	2	513393	3
34	Release Spring	N/A	N/A	307992	8	307992	12	307992	16
52	Inner Spring	308034	48	308034	48	308034	48	308034	48
53	Spring Retainer	415635	16	415635	16	415635	16	415635	16
57	Flat Head Screw	000294 x 0405	72	000294 x 0405	144	000294 x 0405	216	000294 x 0405	288
57	Disc	513395	1	513395	2	513395	3	513395	4
105	Brass Pipe Plug	0000 77 x 0021	1	0000 77 x 0021	1	0000 77 x 0021	1	0000 77 x 0021	1

Item	Description	150DBBS 146524A		250DBBS 146525A		350DBBS 146526A		450DBBS 146527A	
		Part Number	Qty	Part Number	Qty	Part Number	Qty	Part Number	Qty
2	Mounting Flange	515316	1	515316	1	515316	1	515316	1
6	Stud	307111-28	16	307111-27	16	307111-26	16	307111-25	16
8	Friction Block	416691	18	416691	36	416691	54	416691	72
12	Clamp Tube	308440-13	16	308440-12	16	308440-11	16	308440-10	16
14	Pressure Plate	514330	1	514330	1	514330	1	514330	1
16	Spring Housing	514506	1	514506	1	514506	1	514506	1
17	Flat Washer	00006 7 x 0042	32	00006 7 x 0042	32	00006 7 x 0042	32	00006 7 x 0042	32
18	Locknut	000110 x 00 75	16	000110 x 00 75	16	000110 x 00 75	16	000110 x 00 75	16
19	Cylinder	514516	1	514516	1	514516	1	514516	1
20	Hex Head Screw	00019 7 x 134 7	16	00019 7 x 134 7	16	00019 7 x 134 7	16	00019 7 x 134 7	16
21	Inner Lip Seal	000402 x 0042	2	000402 x 0042	2	000402 x 0042	2	000402 x 0042	2
22	Outer Spring	416751-11	112	416751-11	112	416751-11	112	416751-11	112
23	Outer Lip Seal	000402 x 0044	2	000402 x 0044	2	000402 x 0044	2	000402 x 0044	2
27	Spacer Tube	308440-03	16	308440-03	16	308440-03	16	308440-03	16
28	Gear (not included with assembly)	417277-####	1	417278-####	1	417279-####	1	417280-####	1
29	Wear Spacer	N/A	N/A	308546	16	308546	32	308546	48
31	Reaction Plate	N/A	N/A	515314	1	515314	2	515314	3
34	Release Spring	N/A	N/A	416751-12	32	416751-12	48	416751-12	64
52	Inner Spring	N/A	N/A	N/A	N/A	N/A	N/A	N/A	N/A
53	Spring Retainer	4166 74	16	4166 74	16	4166 74	16	4166 74	16
57	Flat Head Screw	000294 x 0405	90	000294 x 0405	180	000294 x 0405	270	000294 x 0405	360
57	Disc	514511	1	514511	2	514511	3	514511	4
105	Brass Pipe Plug	0000 77 x 0021	1	0000 77 x 0021	1	0000 77 x 0021	1	0000 77 x 0021	1

# DBBS Brakes

## 6.2 DBBS Cylinder Seal Kits

Parts included in Kit		Seal Lubricant	Inner Lip Seal (21)	Outer Lip Seal (23)	Instruction Sheet
Model	Kit P/N	Part No. (qty)	Part No. (qty)	Part No. (qty)	Part No. (qty)
20DBBS	107726C	000153 x 1239 (1)	000402x0021 (2)	000402x0022 (2)	20406 7 (1)
25DBBS	107727C	000153 x 1239 (1)	000402x0023 (2)	000402x0024 (2)	20406 7 (1)
38DBBS	107662C	000153 x 1239 (1)	000402x0005 (2)	000402x0006 (2)	20406 7 (1)
50DBBS	108055C	000153 x 1239 (1)	000402x0042 (2)	000402x0044 (2)	20406 7 (1)

## 6.3 DBBS Friction Disc Kits

Model	Kit P/N	Loctite Sealant	Qty	Flat Head Screw	Qty	Wear Spacer	Qty	Friction Disc	Qty	Locknut	Qty	Instruction Sheet	Qty
120	107747B	000153x1016	1	000294x0405	36	N/A	0	513326	2	000110x0030	12	204066	1
220	107747BA	000153x1016	2	000294x0405	72	308155-02	12	513326	4	000110x0030	12	204066	1
320	107747BB	000153x1016	3	000294x0405	108	308155-02	24	513326	6	000110x0030	12	204066	1
420	107747BC	000153x1016	4	000294x0405	144	308155-04	48	513326	8	000110x0030	12	204066	1
125	107748B	000153x1016	1	000294x0405	48	N/A	0	51330 7	2	000110x00 73	12	204066	1
225	107748BA	000153x1016	2	000294x0405	96	3081 70-01	12	51330 7	4	000110x00 73	12	204066	1
325	107748BB	000153x1016	3	000294x0405	144	3081 70-01	24	51330 7	6	000110x00 73	12	204066	1
425	107748BC	000153x1016	4	000294x0405	192	3081 70-01	36	51330 7	8	000110x00 73	12	204066	1
138	107749B	000153x1016	2	000294x0405	72	N/A	0	513396	2	000110x00 75	16	204066	1
238	107749BA	000153x1016	4	000294x0405	144	308150-05	16	513396	4	000110x00 75	16	204066	1
338	107749BB	000153x1168	2	000294x0405	216	308150-05	32	513396	6	000110x00 75	16	204066	1
438	107749BC	000153x1168	2	000294x0405	288	308150-05	48	513396	8	000110x00 75	16	204066	1
150	108155B	000153x1016	3	000294x0405	90	N/A	0	416691	18	000110x00 75	16	204066	1
250	108155BA	000153x1168	1	000294x0405	180	308546	16	416691	36	000110x00 75	16	204066	1
350	108155BB	000153x1168	2	000294x0405	270	308546	32	416691	54	000110x00 75	16	204066	1
450	108155BC	000153x1168	2	000294x0405	360	308546	48	416691	72	000110x00 75	16	204066	1



### Products we offer:

- Cartridge valves
- DCV directional control valves
- Electric converters
- Electric machines
- Electric motors
- Gear motors
- Gear pumps
- Hydraulic integrated circuits (HICs)
- Hydrostatic motors
- Hydrostatic pumps
- Orbital motors
- PLUS+1® controllers
- PLUS+1® displays
- PLUS+1® joysticks and pedals
- PLUS+1® operator interfaces
- PLUS+1® sensors
- PLUS+1® software
- PLUS+1® software services, support and training
- Position controls and sensors
- PVG proportional valves
- Steering components and systems
- Telematics

**Danfoss Power Solutions** is a global manufacturer and supplier of high-quality hydraulic and electric components. We specialize in providing state-of-the-art technology and solutions that excel in the harsh operating conditions of the mobile off-highway market as well as the marine sector. Building on our extensive applications expertise, we work closely with you to ensure exceptional performance for a broad range of applications. We help you and other customers around the world speed up system development, reduce costs and bring vehicles and vessels to market faster.

Danfoss Power Solutions – your strongest partner in mobile hydraulics and mobile electrification.

### Go to [www.danfoss.com](http://www.danfoss.com) for further product information.

We offer you expert worldwide support for ensuring the best possible solutions for outstanding performance. And with an extensive network of Global Service Partners, we also provide you with comprehensive global service for all of our components.

Local address:

### Hydro-Gear

[www.hydro-gear.com](http://www.hydro-gear.com)

### Daikin-Sauer-Danfoss

[www.daikin-sauer-danfoss.com](http://www.daikin-sauer-danfoss.com)

**Danfoss  
Power Solutions (US) Company**  
2800 East 13th Street  
Ames, IA 50010, USA  
Phone: +1 515 239 6000

**Danfoss  
Power Solutions GmbH & Co. OHG**  
Krokamp 35  
D-24539 Neumünster, Germany  
Phone: +49 4321 871 0

**Danfoss  
Power Solutions ApS**  
Nordborgvej 81  
DK-6430 Nordborg, Denmark  
Phone: +45 7488 2222

**Danfoss  
Power Solutions Trading  
(Shanghai) Co., Ltd.**  
Building #22, No. 1000 Jin Hai Rd  
Jin Qiao, Pudong New District  
Shanghai, China 201206  
Phone: +86 21 2080 6201

Danfoss can accept no responsibility for possible errors in catalogues, brochures and other printed material. Danfoss reserves the right to alter its products without notice. This also applies to products already on order provided that such alterations can be made without subsequent changes being necessary in specifications already agreed. All trademarks in this material are property of the respective companies. Danfoss and the Danfoss logotype are trademarks of Danfoss A/S. All rights reserved.