



# DAM SAFETY INSPECTION REPORT

Upper Shaker Lake Dam

File Number: 1314-002

Class I

Cuyahoga County, City Of Shaker Heights

Inspection Date: September 30, 2014



In accordance with Ohio Revised Code Section 1521.062, the owners of dams must monitor, maintain, and operate their dams safely. Negligence of owners in fulfilling these responsibilities can lead to the development of extremely hazardous conditions to downstream residents and properties. In the event of a dam failure, owners can be subject to liability claims.

The Chief of the Division of Soil and Water Resources has the responsibility to ensure that human life, health, and property are protected from the failure of dams. Conducting periodic safety inspections and working with dam owners to maintain and improve the overall condition of Ohio dams are vital aspects of achieving this purpose.

Representatives of the Chief conducted this inspection to evaluate the condition of the dam and its appurtenances under authority of Ohio Revised Code Section 1521.062. In accordance with Ohio Administrative Code Rule 1501:21-21-03, the owners of dams must implement all remedial measures listed in the enclosed report.

*Division of Soil and Water Resources • 2045 Morse Road, Bldg. B-2 • Columbus, Ohio 43229-6693*

*In July 2010, the Ohio Department of Natural Resources, Division of Water, was merged with the Division of Soil and Water Conservation to become the Division of Soil and Water Resources.*

# **Table of Contents**

## **Section 1**

Required Remedial Measures

Discussion Items

Fact Sheets

## **Section 2**

Sketch of Dam

Photographs

Dam Classification Checklist

Flood Routing Summary

Dam History

## **Section 3**

Location Map

Dam Inventory Sheet

Dam Safety Inspection Checklist

# Section 1

## Required Remedial Measures

The requirements listed below are based on observations made during inspection, calculations performed, and requirements of the Ohio Administrative Code (OAC). A checklist noting all observations made during the inspection has been enclosed in Section 3. References to right and left in this report are oriented as if you were standing on the dam crest and looking downstream.

**Engineer Repairs and Investigations:** The owner must retain the services of a professional engineer to address the following items. Plans, specifications, investigative reports, and other supporting documentation, as necessary, must be submitted to the Division of Soil and Water Resources for review and approval prior to construction. **These items have been noted previously and the appropriate time period for completion has already been exceeded. A record of all repairs should be included in the operation, maintenance, and inspection manual.**

- 1. This dam must have emergency action plan (EAP) in accordance with OAC Rule 1501:21-21-04. A registered professional engineer must prepare the inundation map and Section IV (Emergency Detection, Evaluation, and Classification) of the EAP.** It is recommended that your engineer contact the Division of Soil and Water Resources prior to undertaking the engineering study for the inundation map. See additional information in the "Owner Dam Safety Program" portion of this report for additional information.
- 2. The dam's discharge/storage capacity must be sufficient to safely pass the required design flood. Prepare plans and specifications as necessary to increase the discharge/storage capacity to pass the required design flood.** In accordance with OAC Rule 1501:21-13-02, the minimum design flood for Class I dams is 100 percent of the Probable Maximum Flood or the critical flood. See Discussion Item 1 in this section of this report the Flood Routing Summary in Section 2 of this report for additional information.
- 3. This dam must have an emergency spillway in accordance with OAC Rule 1501:21-13-04. Prepare plans and specifications for the installation of an emergency spillway.** This item should be completed in coordination with Item 2 above. See Discussion Item 1 included in this section for additional information.
- 4. The lake drain must be accessible for operation and inspection.** Prepare plans and specifications for installation of a lake drain access structure. See Discussion Item 1 in this section of this report.
- 5. The embankment crest alignment must be uniform. Investigate the vertical alignment of the crest to the left of the spillway and at the right end of the dam and, as necessary, prepare plans and specifications for the correction of any problems.** This item should be completed in coordination with Item 2 above. See Discussion Item 1 in this section of this report.
- 6. The stability of the masonry upstream retaining wall and principal spillway system must be maintained. An engineer must investigate the cracks, missing stones, and eroded stones in these areas. Prepare plans and specifications, as necessary, for the repair of the retaining wall and the principal spillway system. As part of this investigation, your engineer must investigate the seepage on the downstream slope to determine if it is related to problems with the principal spillway outlet. The overall stability of these areas must be monitored weekly regardless of the results of the investigation. See Discussion Item 2 included in this section for additional information.**

7. Investigate the operability of the lake drain valve. If it is found that it no longer functions safely, the owner must install a device to permit draining of the reservoir within a reasonable period of time in accordance with OAC Rule 1501:21-13-06. Prepare plans and specifications for the installation of such a device. See Discussion Item 1 and the "Lake Drains" fact sheet included in this section for additional information.

**Owner Repairs:** The owner must address the following items. The owner may hire a contractor or perform the work him or herself. Repair activities should be documented in the operation, maintenance, and inspection manual.

1. This dam must have a satisfactory trashrack and anti-vortex device in accordance with OAC Rule 1501:21-13-04. Install a trashrack and an anti-vortex device at the inlet of the principal spillway. See the "Design and Maintenance of Trashracks" fact sheet included in this section for additional information.

2. It is highly recommended that a staff gauge be installed at this dam. Please note that the graduations should extend below the normal pool level to allow monitoring during drawdowns. See Discussion Item 3 in this section for additional information.

3. Remove the trees and brush from the upstream and downstream slopes. Seed all disturbed areas to establish a proper grass cover. See the "Trees and Brush" fact sheet included in this section for additional information.

4. Repair the erosion on the right and left ends of the upstream slope and install upstream slope protection. See the "Upstream Slope Protection" fact sheet included in this section for additional information.

**Owner Dam Safety Program:** In accordance with Ohio Revised Code (ORC) Section 1521.062, the owner of a dam shall maintain a safe structure and appurtenances through inspection, maintenance, and operation. A dam, like any other part of the infrastructure, will change and deteriorate over time. Appurtenances such as gates and valves must be routinely exercised to ensure their operability. Inspection and monitoring of the dam identify changing conditions and problems as they develop, and maintenance prevents minor problems from developing into major ones. Dams must have these procedures documented in an operation, maintenance, and inspection manual.

Despite efforts to provide sufficient structural integrity and to perform inspection and maintenance, dams can develop problems that can lead to failure. Early detection and appropriate response are crucial for maintaining the safety of the dam and downstream people and property. The ORC requires the owner to fully and promptly notify the Dam Safety Program of any condition which threatens the safety of the structure. A rapidly changing condition may be an indication of a potentially dangerous problem. The Dam Safety Program can be contacted at 614/265-6731 during business hours or at 614/799-9538 after business hours. Dam owners must have emergency preparedness procedures documented in an emergency action plan.

The owner must address the following items.

1. This dam must have an operation, maintenance, and inspection manual (OMI) and an emergency action plan (EAP) in accordance with OAC Rule 1501:21-21-04. Prepare an OMI and an EAP including an inundation map. Guidelines for the preparation of these documents are included with this report. A registered professional engineer must prepare the inundation map and Section IV (Emergency Detection, Evaluation, and Classification) of the EAP. It is recommended that your engineer contact the Division of Water prior to undertaking the engineering study for the inundation map.
2. Monitor the condition of all masonry stone until an engineer can investigate its condition and make repairs.
3. Monitor the seepage on the left downstream slope of the dam until an engineer can investigate its cause and make repairs.
4. Monitor the bare footpath on the right downstream slope for further damage to the ground cover. A wearing surface may need to be installed in this area if damage of the ground surface continues. See the "Ground Cover" fact sheet included in this section for additional information.

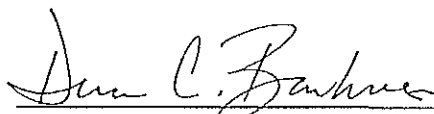
 3-20-15  
\_\_\_\_\_  
Dena C. Barnhouse, P.E. Date  
Project Manager  
Dam Safety Program  
Division of Soil and Water Resources

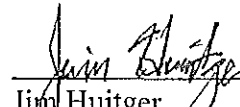
 2/17/2015  
\_\_\_\_\_  
Jim Huitger Date  
Construction Specialist  
Dam Safety Program  
Division of Soil and Water Resources

---

This inspection was performed pursuant to the authority granted to the Chief of the Division of Soil and Water Resources in ORC Section 1521.062.

\_\_\_\_\_  
Keith R. Banachowski, P.E. Date  
Program Manager  
On behalf of Michael D. Bailey, Chief  
Division of Soil and Water Resources

---

## Discussion Items

1. Plans and specifications to repair this dam were submitted by CT Consultants. The proposed repair consisted of installing roller compacted concrete (RCC) on the crest and downstream slope, removing and re-installing the masonry wall on the upstream slope, installing a new lake drain valve, and installing a new trashrack on the principal spillway inlet. These plans were approved by the Division of Soil and Water Resources in 2012. These repairs have not been implemented. Had the plans been implemented, Engineer Items 2, 3, 4, 5 and 7 of this report would no longer be required. Please note that the plans did not include any measures to investigate or control seepage through the dam or the spillway conduit as was required in the 2009 Dam Safety Inspection Report. In addition, the spillway conduit was reinforced with steel I-beams in 2013. To date, no engineering plans have been submitted that show how the spillway conduit was reinforced. Before proceeding with any other construction, please reassess the existing repair plans and include any other required items then submit the plans to this office for review and approval.
2. Based on the condition of the principal spillway conduit and the seepage on the downstream slope, you are encourage to carefully check for any sinkholes on the dam or any increase in seepage. These occurrences could indicate a serious problem for the dam. The concrete on the crest should be regularly sounded for any hollow areas, and the downstream slope above the principal spillway outlet structure should also be closely checked for any sinkholes.
3. A staff gauge helps the owner more accurately document pool levels during flood events and during routine inspections. It is very helpful to correlate seepage through drains to pool level. Please note that the graduations/numbers should extend beneath the lake level so that lowering of the pool (should it be needed or desired) can be monitored. It should be positioned to allow easy reading from a safe location. An example of a staff gauge is shown below.

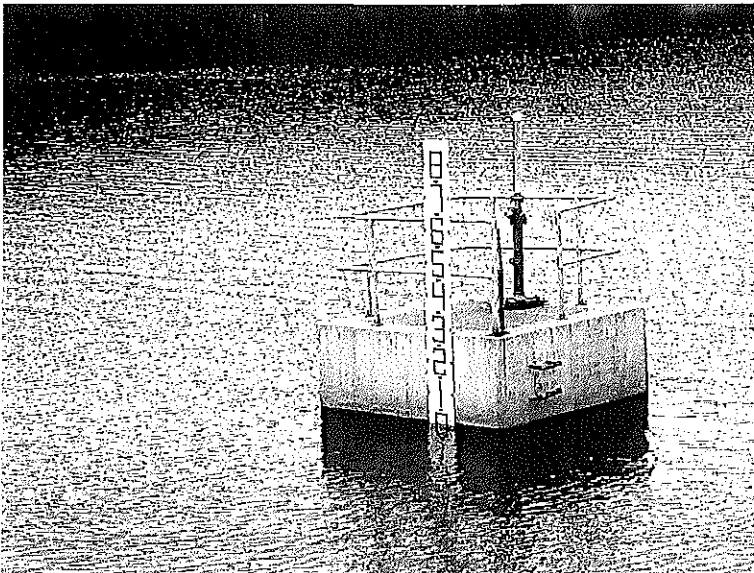



## Dam Safety: Lake Drains

A lake drain is a device to permit draining a reservoir, lake or pond. Administrative Rule 1501:21-13-06 requires that all Class I, Class II and Class III dams include a lake drain.

### Types of Drains

Common types of drains include the following:

- ◆ A valve located in the spillway riser.
- ◆ A conduit through the dam with a valve at either the upstream or downstream end of the conduit.
- ◆ A siphon system (Often used to retrofit existing dams).
- ◆ A gate, valve or stoplogs located in a drain control tower.

### Uses of Drains

The following situations make up the primary uses of lake drains:

**Emergencies:** Should serious problems ever occur to threaten the immediate safety of the dam, drains may be used to lower the lake level to reduce the likelihood of dam failure. Examples of such emergencies are as follows: clogging of the spillway pipe which may lead to high lake levels and eventually dam overtopping, development of slides or cracks in the dam, severe seepage through the dam which may lead to a piping failure of the dam, and partial or total collapse of the spillway system.

**Maintenance:** Some repair items around the lake and dam can only be completed or are much easier to perform with a lower than normal lake level. Some examples are: slope protection repair, spillway repairs, repair and/or installation of docks and other structures along the shoreline, and dredging the lake.

**Winter Drawdown:** Some dam owners prefer to lower the lake level during the winter months to reduce ice damage to structures along the shoreline and to provide additional flood storage for upcoming spring rains. Several repair items are often performed during this winter drawdown period. Periodic fluctuations in the lake level also discourage muskrat and beaver habitation along the shoreline. Muskrat burrows in earthen dams can lead to costly repairs.

### Common Maintenance Problems

Common problems often associated with the maintenance and operation of lake drains include the following:

- ◆ Deteriorated and bent control stems and stem guides.
- ◆ Deteriorated and separated conduit joints.
- ◆ Leaky and rusted control valves and sluice gates.
- ◆ Deteriorated ladders in control towers.
- ◆ Deteriorated control towers.
- ◆ Clogging of the drain conduit inlet with sediment and debris.
- ◆ Inaccessibility of the control mechanism to operate the drain.
- ◆ Seepage along the drain conduit.
- ◆ Erosion and undermining of the conduit discharge area because the conduit outlets significantly above the elevation of the streambed.
- ◆ Vandalism.
- ◆ Development of slides along the upstream slope of the dam and the shoreline caused by lowering the lake level too quickly.

### Operation and Maintenance Tips

- A. All gates, valves, stems and other mechanisms should be lubricated according to the manufacturer's specifications. If you do not have a copy of the specifications and the manufacturing company can not be determined, then a local valve distributor may be able to provide assistance.
- B. The lake drain should be operated at least twice a year to prevent the inlet from clogging with sediment and debris, and to keep all movable parts working easily. Most manufacturers recommend that gates and valves be operated at least four times per year. Frequent operation will help to ensure that the drain will be operable when it is needed. All valves and gates should be fully opened and closed at least twice to help flush out debris and to obtain a proper seal. If the gate gets stuck in a partially opened position, gradually work the gate in

*Continued on back!*

each direction until it becomes fully operational. Do not apply excessive torque as this could bend or break the control stem, or damage the valve or gate seat. With the drain fully open, inspect the outlet area for flow amounts, leaks, erosion and anything unusual.

- C. All visible portions of the lake drain system should be inspected at least annually, preferably during the periodic operation of the drain. Look for and make note of any cracks, rusted and deteriorated parts, leaks, bent control stems, separated conduit joints or unusual observations.
- D. A properly designed lake drain should include a headwall near the outlet of the drain conduit to prevent undermining of the conduit during periods of flow. A headwall can be easily retro-fitted to an existing conduit if undermining is a problem at an existing dam. A properly designed layer of rock riprap or other slope protection will help reduce erosion in the lake drain outlet area.
- E. Drain control valves and gates should always be placed upstream of the centerline of the dam. This allows the drain conduit to remain depressurized except during use, therefore reducing the likelihood of seepage through the conduit joints and saturation of the surrounding earth fill.
- F. For accessibility ease, the drain control platform should be located on shore or be provided with a bridge or other structure. This becomes very important during emergency situations if high pool levels exist.
- G. Vandalism can be a problem at any dam. If a lake drain is operated by a crank, wheel or other similar mechanism, locking with a chain or other device, or off-site storage may be beneficial. Fences or other such installations may also help to ward off vandals.
- H. The recommended rate of lake drawdown is one foot or less per week, except in emergencies. Fast draw-down causes a build-up of hydrostatic pressures in the upstream slope of the dam which can lead to slope failure. Lowering the water level slowly allows these pressures to dissipate.

### Monitoring

Monitoring of the lake drain system is necessary to detect problems and should be performed at least twice a year or more frequently if problems develop. Proper ventilation and confined space precautions must be considered when entering a lake drain vault or outlet pipe. Items to be considered when monitoring a lake drain system include the stem, valve, outlet pipe and related appurtenances. Monitoring for surface deterioration (rust), ease of operation, and leakage is important to maintain a working lake drain system. If the stem or valve appears to be inoperable because of deterioration or if the operability of the lake drain system is in question, because the valve does not completely close (seal) and allows an excessive amount of leakage, then a registered professional engineer or manufacturer's representative should be contacted. Photographs along with written records of the monitoring items performed provide invaluable information. For further information on evaluating the condition of the lake drain system see the "Spillway Conduit System Problems", "Problems with Metal Materials", "Problems with Plastic (Polymer) Materials", and "Problems with Concrete Materials" fact sheets.

### Conclusion

An operable lake drain accomplishes the following:

1. Makes for a safer dam by providing a method to lower the lake level in an emergency situation.
2. Allows the dam owner to have greater control of the lake level for maintenance, winter drawdown and emergency situations.
3. Meets the requirements of the Ohio Dam Safety Laws.

Any other questions, comments concerns, or fact sheet requests, should be directed to the Division of Water at the following address:

Ohio Department of Natural Resources  
Division of Soil and Water Resources  
Dam Safety Engineering Program  
2045 Morse Road  
Columbus, Ohio 43229-6693  
Voice: (614) 265-6731 Fax: (614) 447-9503  
E-mail: [dswc@dnr.state.oh.us](mailto:dswc@dnr.state.oh.us)  
Website: <http://ohiodnr.gov/soilandwater>  
**Emergency 24hr hotline: 614-799-9538**





## Dam Safety: Design and Maintenance of Trashracks for Pipe and Riser Spillways

The principal spillway for dams in the State of Ohio can be one of several designs. The proper operation of these spillways is an important part of maintaining the overall safety of the dam. Pipe and riser, drop inlet, and slant pipe spillways are susceptible to obstruction and damage by floating debris such as leaves, branches, and logs. One device used to ensure that these spillways operate correctly is a trashrack. Trashracks are designed to keep trash and other debris from entering the spillway and causing damage.

### Common problems

Trashracks usually become plugged because the openings are too small or the head loss at the inlet causes material and sediment to settle out and accumulate. Small openings will cause debris such as twigs and leaves to accumulate on the trashrack bars. This buildup will cause progressively larger debris to accumulate against the trashrack bars. Ultimately, this will result in the complete blockage of the spillway inlet.

Pipe and riser spillways can also become blocked by a build up of debris in the spillway. This type of blockage occurs when no trashrack is in place, or if the openings are too large.

In many spillway systems, the size of the outlet conduit is smaller than the size of the inlet. Therefore, it is incorrect to assume that debris which passes through the inlet will not obstruct the flow through the outlet. Large debris, such as logs and tree limbs, can become lodged in the transitions in the spillway. This reduces the capacity of the spillway and could cause damage. An obstructed outlet pipe can be a major problem because removal of large debris from inside the spillway can be very difficult.

A partially blocked spillway reduces the capacity of the spillway and may also create a higher than normal pool level. The combination of these two factors can dramatically reduce the discharge/storage capacity of the dam. A reduction in the discharge/storage capacity of a dam increases the likelihood that the dam will be overtopped during a severe storm event. Overtopping for even a short period of time can cause damage to the embankment and possibly failure of the dam. If the dam has an emergency spillway, a blocked principal spillway will cause more frequent flows in the emergency spillway. Since emergency spillways are usually grass lined channels designed for infrequent flows of short duration, serious damage is likely to result.

### Trashrack design

A well-designed trashrack will stop large debris that could plug the conduit but allow unrestricted passage of water and smaller debris. The larger the outlet conduit, the larger the trashrack opening should be. In the design of a trashrack the openings should be sized so that they measure one-half the nominal dimension of

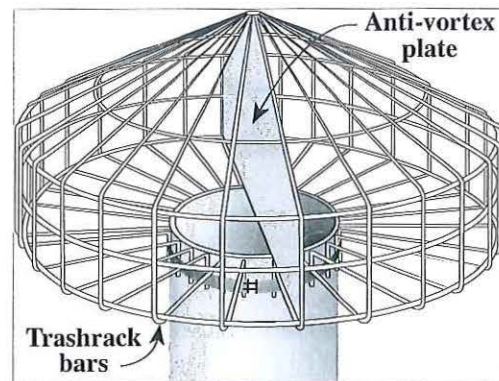

the outlet conduit. For example, if the outlet pipe is 18 inches in diameter, the trashrack openings should be the effective equivalent of 9 inches by 9 inches; if the outlet conduit is 3 feet by 5 feet, the trashrack openings should be the effective equivalent of 18 inches by 18 inches. This rule applies up to a maximum trashrack opening of two feet by two feet. For an outlet conduit with a nominal dimension of 12 inches or less, the trashrack openings should be at least 6 inches by 6 inches. This prevents large debris from passing through the inlet and blocking the outlet conduit while allowing smaller debris (leave, sticks, etc.) to flush through the spillway system. Another important design criteria is that the trashrack should be securely fastened to the inlet. The connection must be strong enough to withstand the hydrostatic and dynamic forces exerted on the trashrack during periods of high flow.

### Fish protection

Many owners are concerned about losing fish through trashracks that have large openings. If this is a concern, a metal plate surrounding the riser or drop inlet which extends above and below the normal pool level should be installed. See Figure on back of sheet. On the bottom of the plate, a metal screen should be attached and connected to the riser pipe. The solid plate at the water level will prevent the fish and floating debris from passing over the crest of the riser. The underwater screen will keep the fish from moving under the metal plate and through the spillway. The underwater screen will not become blocked because most of the debris floats

*Continued on back!*

on the water surface. If this design is used, the area between the inside of the cylinder and the outside of the riser must be equal to or greater than the area inside the riser.

### Anti-vortex devices

An anti-vortex device can easily be incorporated into most trashrack designs. A common anti-vortex device is a flat metal plate which is placed on edge and attached to the inlet of the spillway. See Figure below. The capacity of the spillway will be

**Basic Anti-vortex Plate Design**

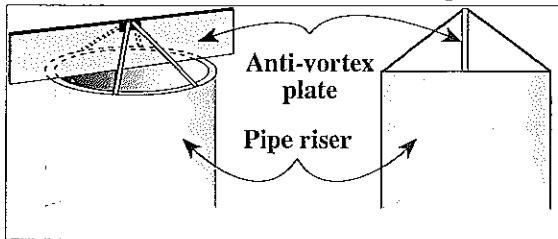

increased by equipping the trashrack with an anti-vortex plate. The anti-vortex plate increases capacity by preventing the formation of a flow inhibiting vortex during periods of high flow.

### Maintenance

Maintenance should include periodic checks of the trashrack for rusted and broken sections and repairing as needed. Trashracks should be checked frequently during and after storm events to ensure they are functioning properly and to remove accumulated

debris. Extreme caution should be used when attempting to remove accumulated debris during periods of high flow.

### Conclusion

The benefits of a properly designed and maintained trashrack include the following:

1. Efficient use of the existing spillway system that will maintain the design discharge/storage capacity of the dam and prevent overtopping.
2. Prevention of costly maintenance items such as the removal of debris from the spillway, repair or replacement of damaged spillway components, and the repair of erosion in emergency spillway.
3. A reduction in the amount of fish lost through the spillway system if a fish screen is used.

Any questions, comments, concerns, or fact sheet requests should be directed to:

Ohio Department of Natural Resources  
 Division of Soil and Water Resources  
 Dam Safety Engineering Program  
 2045 Morse Road  
 Columbus, Ohio 43229-6693  
 Voice: (614) 265-6731 Fax: (614) 447-9503  
 E-mail: dswc@dnr.state.oh.us  
 Website: <http://ohiodnr.gov/soilandwater>  
 Emergency 24hr hotline: 614-799-9538

**Trash Rack Design With Fish Protector Screen**

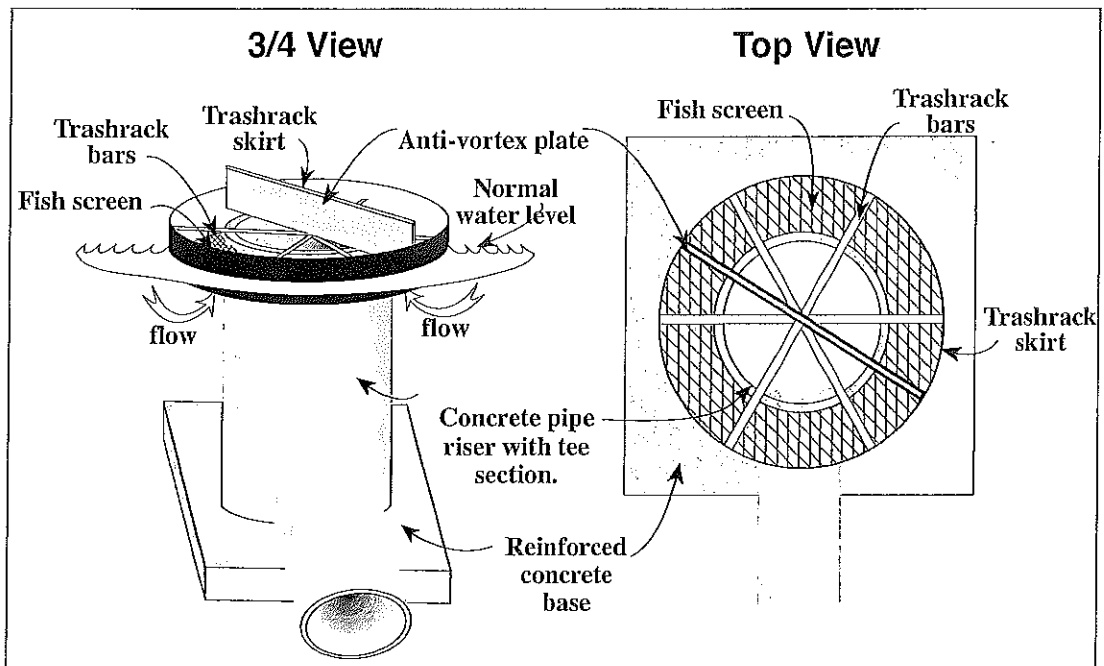



Ohio Department of Natural Resources  
**Division of Soil and Water Resources**  
Fact Sheet

Fact Sheet 94-28

## Dam Safety: Trees and Brush

**T**he establishment and control of proper vegetation is an important part of dam maintenance. Properly maintained vegetation can help prevent erosion of embankment and earth channel surfaces, and aid in the control of groundhogs and muskrats. The uncontrolled growth of vegetation can damage embankments and concrete structures and make close inspection difficult.

### Trees and Brush

Trees and brush should not be permitted on embankment surfaces or in vegetated earth spillways. Extensive root systems can provide seepage paths for water. Trees that blow down or fall over can leave large holes in the embankment surface that will weaken the embankment and can lead to increased erosion. Brush obscures the surface limiting visual inspection, provides a haven for burrowing animals, and retards growth of grass vegetation. Tree and brush growth adjacent to concrete walls and structures may eventually cause damage to the concrete and should be removed.

### Stump Removal & Sprout Prevention

Stumps of cut trees should be removed so vegetation can be established and the surface mowed. Stumps can be removed either by pulling or with machines that grind them down. All woody material should be removed to about 6 inches below the ground surface. The cavity should be filled with well-compacted soil and grass vegetation established.

Stumps of trees in riprap cannot usually be pulled or ground down, but can be chemically treated so they will not continually form new sprouts. Certain herbicides are effective for this purpose and can even be used at water supply reservoirs if applied by licensed personnel. For product information and information on how to obtain a license, contact the Ohio Department of Agriculture at the following address:

Ohio Department of Agriculture  
Pesticide Regulation  
8995 E. Main Street  
Reynoldsburg, Ohio 43068  
Telephone Number (614) 728-6987

These products should be painted, not sprayed, on the stumps. Other instructions found on the label should be strictly followed when handling and applying these materials. Only a few commercially available chemicals can be used along shorelines or near water.

### Embankment Maintenance

Embankments, areas adjacent to spillway structures, vegetated channels, and other areas associated with a dam require continual maintenance of the vegetal cover. Grass mowing, brush cutting, and removal of woody vegetation (including trees) are necessary for the proper maintenance of a dam, dike, or levee. All embankment slopes and vegetated earth spillways should be maintained with a maximum grass height of 12 inches. Aesthetics, unobstructed viewing during inspections, maintenance of a non-erodible surface, and discouragement of groundhog habitation are reasons for proper maintenance of the vegetal cover.

Methods used in the past for control of vegetation, but are now considered unacceptable, include chemical spraying, and burning. More acceptable methods include the use of weed whips or power brush-cutters and mowers. Chemical spraying to first kill small trees and brush is acceptable if precautions are taken to protect the local environment.

It is important to remember not to mow when the embankment is wet. It is also important to use proper equipment for the slope and type of vegetation to be cut. Also, always follow the manufacturer's recommended safe operation procedures.

Any other questions, comments, concerns, or fact sheet requests, should be directed to the Division of Water at the following address:

Ohio Department of Natural Resources  
Division of Soil and Water Resources  
Dam Safety Engineering Program  
2045 Morse Road  
Columbus, Ohio 43229-6693  
Voice: (614) 265-6731 Fax: (614) 447-9503  
E-mail: [dswc@dnr.state.oh.us](mailto:dswc@dnr.state.oh.us)  
Website: <http://ohiodnr.gov/soilandwater>  
**Emergency 24hr hotline: 614-799-9538**





Ohio Department of Natural Resources  
**Division of Soil and Water Resources**  
Fact Sheet

Fact Sheet 99-52

## Dam Safety: Upstream Slope Protection

**S**lope protection is usually needed to protect the upstream slope against erosion due to wave action. Without proper slope protection, a serious erosion problem known as “beaching” can develop on the upstream slope.

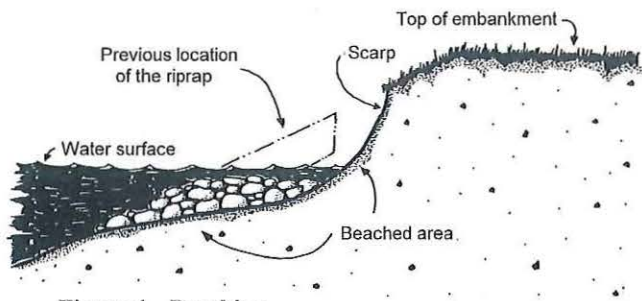

Figure 1 - Beaching

The repeated action of waves striking the embankment surface erodes fill material and displaces it farther down the slope, creating a “beach.” The amount of erosion depends on the predominant wind direction, the orientation of the dam, the steepness of the slope, water level fluctuations, boating activities, and other factors. Further erosion can lead to cracking and sloughing of the slope which can extend into the crest, reducing its width. When erosion occurs and beaching develops on the upstream slope of a dam, repairs should be made as soon as possible. However, an erosion scarp less than 1 foot high may be stable and not require repair.

The upstream face of a dam is commonly protected against wave erosion by placement of a layer of rock riprap over a layer of bedding and a filter material. Other material such as concrete facing, soil-cement, fabri-form bags, slush grouted rocks, steel sheet piling, and articulated concrete blocks can also be used. Vegetative protection combined with a berm on the upstream slope can also be effective.

### Rock Riprap

Rock riprap consists of a heterogeneous mixture of irregular shaped rocks placed over gravel bedding and a sand filter or geotextile fabric. The smaller rocks help to fill the spaces between the larger pieces forming an interlocking mass. The filter prevents soil particles on the embankment surface from being washed out through the spaces (or voids) between the rocks. The maximum rock

size and weight must be large enough to break up the energy of the maximum anticipated wave action and hold the smaller stones in place. If the rock size is too small, it will eventually be displaced and washed away by wave action. If the riprap is sparse or if the filter or bedding material is too small, the filter material will wash out easily, allowing the embankment material to erode. Once the erosion has started, beaching will develop if remedial measures are not taken. Technical Release No. 69 developed by the USDA, Natural Resources Conservation Service can be used to help design engineers develop a preliminary or detailed design for riprap slope protection.

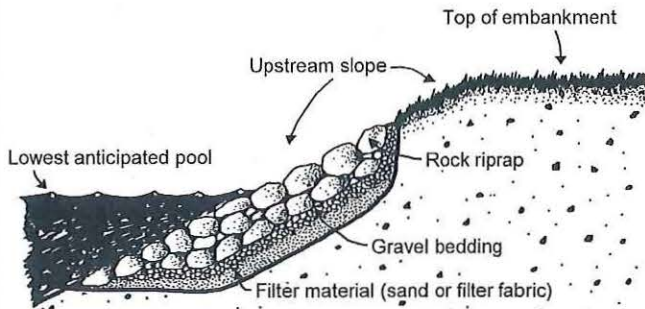

Figure 2 - Rock Riprap

The dam owner should expect some deterioration (weathering) of riprap. Freezing and thawing, wetting and drying, abrasive wave action, and other natural processes will eventually break down the riprap. Its useful life varies with the characteristics of the stone used. Stone for riprap should be rock that is dense and well cemented. In Ohio, glacial cobbles or boulders, most limestone, and a few types of sandstone are acceptable for riprap. Most sandstones and shales found in Ohio do not provide long-term protection. Due to the high initial cost of rock riprap, its durability should be determined by appropriate testing procedures prior to installation. Vegetative growth within the slope protection is undesirable because it can displace stone and disturb the filter material. Heavy undergrowth prevents an adequate inspection of the upstream slope and may hide potential problems. For additional information, see the “Trees and Brush” fact sheet.

*Continued on back!*

Sufficient maintenance funds should be allocated for the addition of riprap and the removal of vegetation. Severe erosion or reoccurring problems may require a registered professional engineer to design a more effective slope protection.

### Vegetated Wave Berm

Vegetated wave berms dissipate wave energy and protect the slope from erosion. Berms are constructed on the upstream slope at the normal pool level and should be no less than 20 feet wide. This method of slope protection will not work well where the water surface fluctuates regularly from normal pool. If improper or sparse vegetation is present, the wave berm may not adequately dissipate the wave energy, allowing erosion and beaching to develop on the upstream slope. Technical Release No. 56 developed by the USDA, Natural Resources Conservation Service provides design and layout information.

The vegetation on the wave berm should be monitored regularly to verify adequate growth. Sufficient funds should be allocated for the regular maintenance of the vegetation. Severe erosion or reoccurring problems may require a registered professional engineer to design a more effective slope protection.

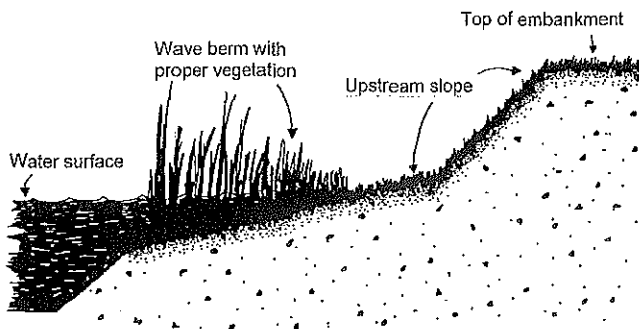

Figure 3 - Vegetated wave berm

### Concrete Facing

Concrete facing can be used if severe wave action is anticipated, however, settlement of the embankment must be insignificant to insure adequate support for the concrete facing. A properly designed and constructed concrete facing can be expensive. This slope protection should extend several feet above and below the normal pool level. It should terminate on a berm or against a concrete curb or header. Granular filter or filter fabric (geotextile) is required under the concrete facing to help reduce the risk of undermining.

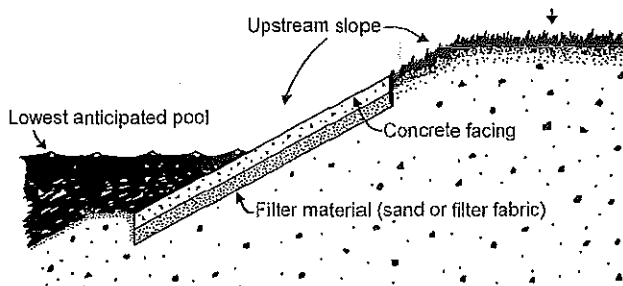

Figure 4 - Concrete facing

As with any type of slope protection, problems will develop if the concrete facing has not been properly designed or installed. Concrete facing often fails because the wave action washes soil particles from beneath the slabs through joints and cracks. This process is known as undermining, which will continue until large voids are created. Detection of voids is difficult because the voids are hidden. Failure of the concrete facing may be sudden and extensive. Concrete facing should be monitored for cracks and open joints. Open joints should be sealed with plastic fillers and cracks should be grouted and sealed. For additional information, see the "Problems with Concrete Materials" fact sheet.

### Inspection and Monitoring

Regular inspection and monitoring of the upstream slope protection is essential to detect any problems. It is important to keep written records of the location and extent of any erosion, undermining, or deterioration of the riprap, wave berm or other slope protection. Photographs provide invaluable records of changing conditions. A rapidly changing condition may indicate a very serious problem, and the Dam Safety Engineering Program should be contacted immediately. All records should be kept in the operation, maintenance, and inspection manual for the dam.

Any other questions, comments concerns, or fact sheet requests, should be directed to:

Ohio Department of Natural Resources  
 Division of Soil and Water Resources  
 Dam Safety Engineering Program  
 2045 Morse Road  
 Columbus, Ohio 43229-6693  
 Voice: (614) 265-6731 Fax: (614) 447-9503  
 E-mail: [dswc@dnr.state.oh.us](mailto:dswc@dnr.state.oh.us)  
 Website: <http://ohiodnr.gov/soilandwater>  
**Emergency 24hr hotline: 614-799-9538**





Ohio Department of Natural Resources  
**Division of Soil and Water Resources**  
Fact Sheet

Fact Sheet 99-54

## Dam Safety: Ground Cover

**T**he establishment and control of proper vegetation are an important part of dam maintenance. Properly maintained vegetation can help prevent erosion of embankment and earth channel surfaces, and aid in the control of groundhogs and muskrats. The uncontrolled growth of vegetation can damage embankments and concrete structures and make close inspection difficult.

Grass vegetation is an effective and inexpensive way to prevent erosion of embankment surfaces. If properly maintained, it also enhances the appearance of the dam and provides a surface that can be easily inspected. Roots and stems tend to trap fine sand and soil particles, forming an erosion-resistant layer once the plants are well established. Grass vegetation may not be effective in areas of concentrated runoff, such as at the contact of the embankment and abutments, or in areas subjected to wave action.

### Common Problems

#### Bare Areas

Bare areas on an embankment are void of protective cover (e.g. grass, asphalt, riprap etc.). They are more susceptible to erosion which can lead to localized stability problems such as small slides and sloughs. Bare areas must be repaired by establishing a proper grass cover or by installing other protective cover. If using grass, the topsoil must be prepared with fertilizer and then scarified before sowing seed. Types of grass vegetation that have been used on dams in Ohio are bluegrass, fescue, ryegrass, alfalfa, clover, and redtop. One suggested seed mixture is 30% Kentucky Bluegrass, 60% Kentucky 31 Fescue, and 10% Perennial Ryegrass. Once the seed is sown, the area should be mulched and watered regularly.

#### Erosion

Embankment slopes are normally designed and constructed so that the surface drainage will be spread out in a thin layer as "sheet flow" over the grass cover. When the sod is in poor condition or flow is concentrated at one or more locations, the resulting erosion will leave rills and gullies in the embankment slope. The erosion will cause loss of material and make maintenance of the embankment difficult. Prompt repair of the erosion is required to prevent more serious damage to the embankment. If

erosion gullies are extensive, a registered professional engineer may be required to design a more rigid repair such as riprap or concrete. Minor rills and gullies can be repaired by filling them with compacted cohesive material. Topsoil should be a minimum of 4 inches deep. The area should then be seeded and mulched. Not only should the eroded areas be repaired, but the cause of the erosion should be addressed to prevent a continued maintenance problem.

#### Footpaths

Paths from animal and pedestrian traffic are problems common to many embankments. If a path has become established, vegetation in this area will not provide adequate protection and a more durable cover will be required unless the traffic is eliminated. Gravel, asphalt, and concrete have been used effectively to cover footpaths. Embedding railroad ties or other treated wood beams into an embankment slope to form steps is one of the most successful and inexpensive methods used to provide a protected pathway.

#### Vehicle Ruts

Vehicle ruts can also be a problem on the embankment. Vehicular traffic on the dam should be discouraged especially during wet conditions except when necessary. Water collected in ruts may cause localized saturation, thereby weakening the embankment. Vehicles can also severely damage the vegetation on embankments. Worn areas could lead to erosion and more serious problems. Ruts that develop in the crest should be repaired by grading to direct all surface drainage into the impoundment. Bare and eroded areas should be repaired using the methods mentioned in the above sections. Constructed barriers such as fences and gates are effective ways to limit access of vehicles.

#### Improper Vegetation

Crown vetch, a perennial plant with small pink flowers, has been used on some dams in Ohio but is not recommended (see Figure 1). It hides the embankment surface, preventing early detection of cracks and erosion. It is not effective in preventing erosion.

*Continued on back!*



**Figure 1: Crown Vetch**  
(Source: <http://www.vg.com>)

Vines and woody vegetation such as trees and brush also hide the embankment surface preventing early detection of cracks and erosion. Tall vegetation also provides a habitat for burrowing animals. All improper vegetation must be removed from the entire embankment surface. Any residual roots that are larger than 3 inches in diameter must be removed. All roots should be removed down to a depth of at least 6 inches and replaced with a compacted clay material; then 4 inches of topsoil should be placed on the disturbed areas of the slope. Finally, these areas must be seeded and mulched to establish a proper grass cover.

## Maintenance

Embankments, areas adjacent to spillway structures, vegetated channels, and other areas associated with a dam require continual maintenance of the vegetal cover. Removal of improper vegetation is necessary for the proper maintenance of a dam, dike or levee. All embankment slopes and vegetated earth spillways should be maintained with a maximum grass height of 12 inches. Reasons for proper maintenance of the vegetal cover include unobstructed viewing during inspection, maintenance of a non-erodible surface, discouragement of burrowing animal habitation, and aesthetics.

Common methods for control of vegetation include the use of weed trimmers or power brush-cutters and mowers. Chemical spraying to kill small trees and brush is acceptable if precautions are taken to protect the local environment. Some chemical spraying may require proper training prior to application. Additional information can be found on the Trees and Brush Fact Sheet.

Any other questions, comments concerns, or fact sheet requests, should be directed to:

Ohio Department of Natural Resources  
Division of Soil and Water Resources  
Dam Safety Engineering Program  
2045 Morse Road  
Columbus, Ohio 43229-6693  
Voice: (614) 265-6731 Fax: (614) 447-9503  
E-mail: [dswc@dnr.state.oh.us](mailto:dswc@dnr.state.oh.us)  
Website: <http://ohiodnr.gov/soilandwater>  
**Emergency 24hr hotline: 614-799-9538**

