

**Seamless  
Data Center Interconnect options using  
EVPN & various tunnel stitching  
ID 4469**





Michal Styszynski

October 18<sup>th</sup>, 2022 – NANOG 86, Hollywood, CA

# Agenda

- Why 'Seamless EVPN-VxLAN stitching' ?
- L2 and L3 DCI Overlay design options
- Seamless EVPN-VxLAN stitching – packet walk
  - EVPN-VXLAN to EVPN-VXLAN EVPN Type-2 & Type-5
  - EVPN-VXLAN to EVPN-MPLS

# Why seamless tunnel stitching in DC and DCI use-case ?

	Multi-pod or DCI evpn-vxlan tunnel scale control	The vxlan-to-vxlan stitching allows to reduce and control the number of vxlan tunnels between DC rooms and sites, when running EVPN-VXLAN fabric
	Easier architecture extensions when workloads are growing	Adding another pod into the existing DC architecture is simpler with no impact on the existing pod leaf operation
	More efficient Ethernet flooding	Better flooding between DC rooms or sites when just selected L2& L3 domain are extended
	Additional virtualization & security option	Each DC site can have different set of VNIs to secure tenant while still deliver same broadcast domain
	Improved operations	The operator/admin can decide which workloads get extended

# Main use-case for tunnel stitching

Seamless  
tunnel  
stitching

1

## multi-pod L2 / L3 DC

- larger dc fabrics with selective L2 VNI and RVNI stretch

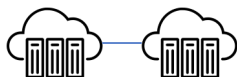

Multi-Pod L2/L3  
Data Center

- EVPN-VXLAN to EVPN-VXLAN
- Server overlays gateway to the fabric

2

## L2 / L3 DCI

- multiple DC sites (2 or more)
- medium/large DC

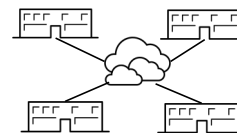

Multi-site L2/L3 DCI

- EVPN-VXLAN to EVPN-VXLAN
- EVPN-VXLAN to EVPN-MPLS
- EVPN-VXLAN to EVPN-SRv6

# Simplified DCI design options

## Option 1

Decoupled Interconnect model using L2 VLAN handoff – L2 DCI

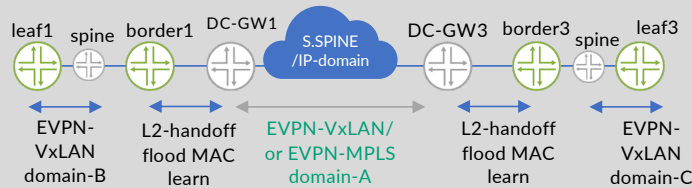

- Harder to manage - more devices/equipment
- Traditional demarcation points
- Flood based MAC learning

## Option 2

OTT – over the top full-mesh interconnect – L2 DCI

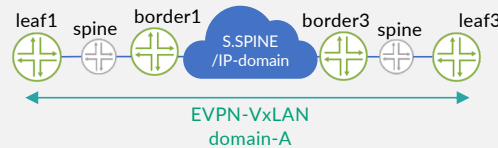

- Intermediate scale and control
- Lack of clear demarcation points
- One EVPN-VXLAN domain between DC sites

## Option 3

Seamless EVPN-VxLAN to EVPN-VXLAN seamless stitching - L2 DCI

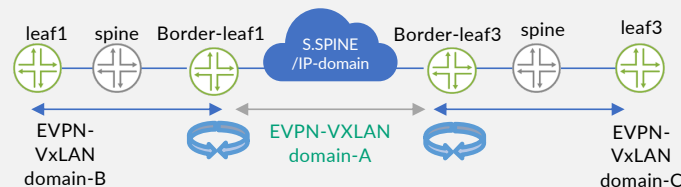

- Unified EVPN layer 2 solution
- Pure overlay with controlled scaling
- Higher scale—more DC sites and pods
- rfc9014



# Simplified DCI design options

## Option 4

Seamless EVPN-VxLAN to EVPN-MPLS seamless stitching - L2 DCI

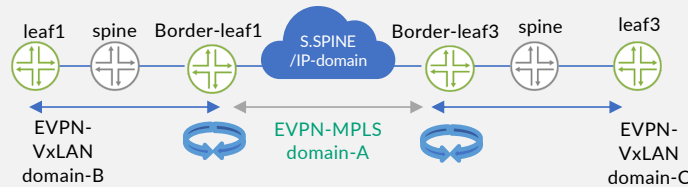

- Unified EVPN layer 2 solution
- Pure overlay with controlled scaling
- Higher scale—more DC sites and pods
- MPLS direct connect from border-leaf



## Option 5

EVPN Type-5 to EVPN Type-5 VxLAN to VxLAN stitching L3 DCI

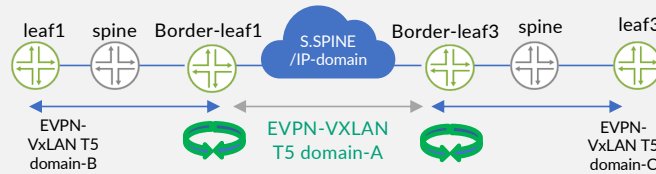

- Unified EVPN layer 3 solution
- Pure overlay with controlled scaling
- Higher scale—more DC sites and pods
- VXLAN for IP only DCI



## Option 6

EVPN-VXLAN Type-5 to IPVPN MPLS - L3 DCI

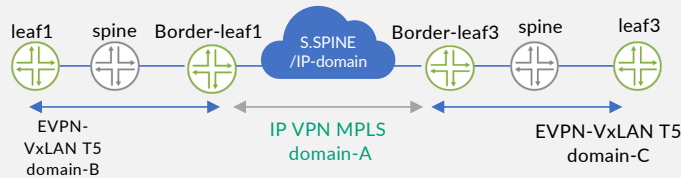

- Unified EVPN layer 3 solution
- Pure overlay with controlled scaling
- Higher scale—more DC sites and pods
- MPLS IPVPN using IP only DCI



# **EVPN-VXLAN to EVPN-VXLAN tunnel stitching - EVPN T2/T2 & T5/T5**

# SEAMLESS EVPN-VXLAN STITCHING - USING BORDER SPINE

- By default, the NH of the MAC@ is changed in case of seamless stitching overlay DCI
- RT/RD rewrite operation for RT1-->RT3

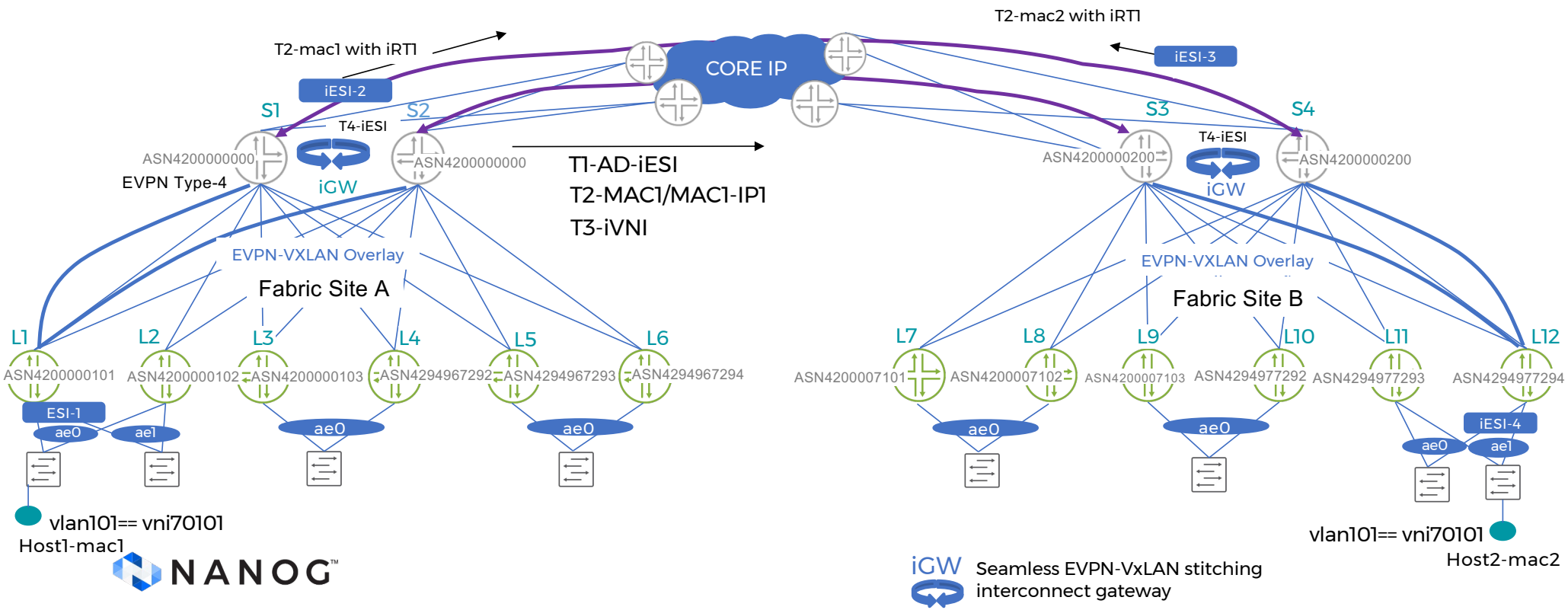



# SEAMLESS EVPN-VXLAN STITCHING - USING BORDER-LEAF

- By default, the NH of the MAC@ is changed in case of seamless stitching overlay DCI
- RT/RD rewrite operation for RT1-->RT3
- RT4 for DF/nDF election per iESI

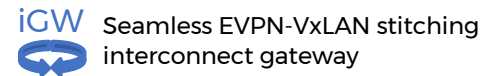
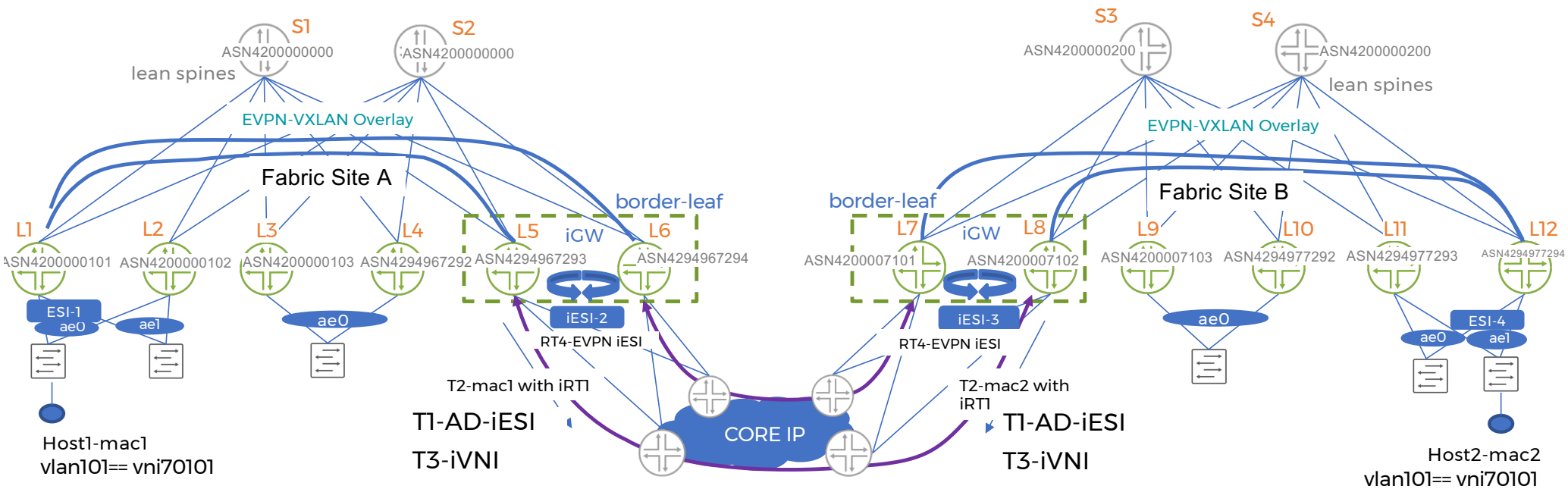

# SEAMLESS EVPN-VXLAN STITCHING - PURE TYPE-5 EVPN

- By default, the NH of the IP prefix is changed in case of seamless stitching overlay DCI
- RT/RD rewrite operation for EVPN RT5
- No local IFL interfaces creations

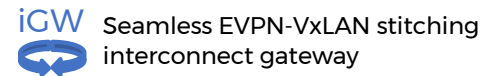
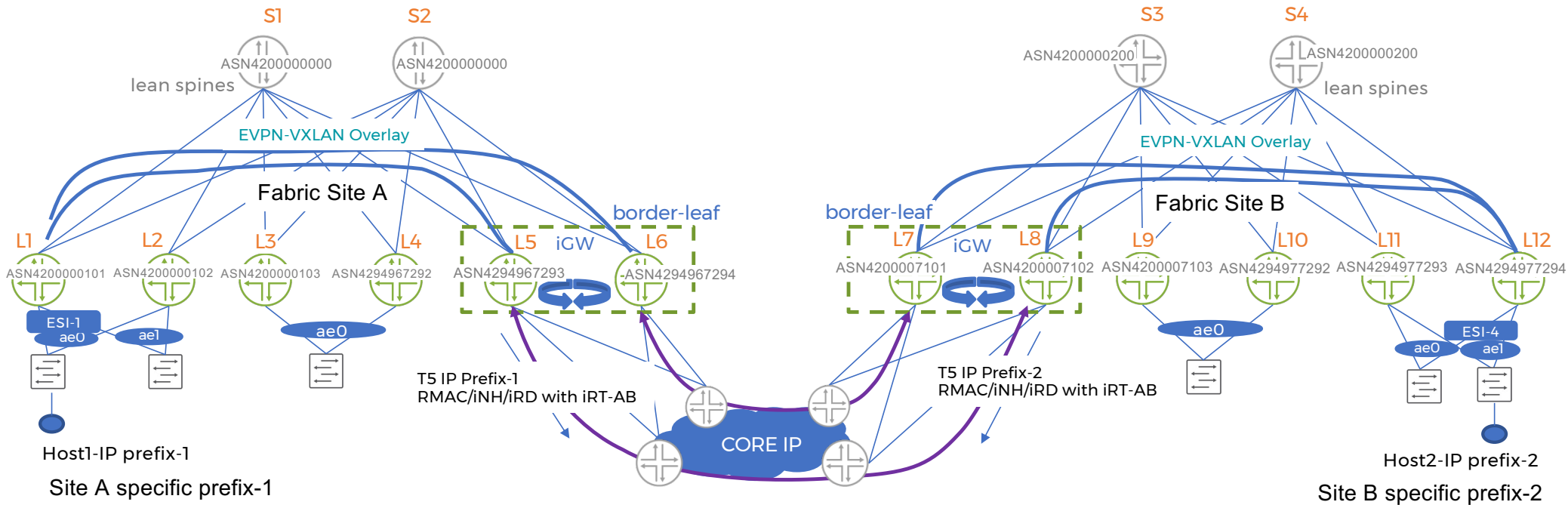

# MAC-VRF and Seamless tunnel stitching



# MAC-VRF ISOLATION and SEAMLESS TUNNEL STITCHING

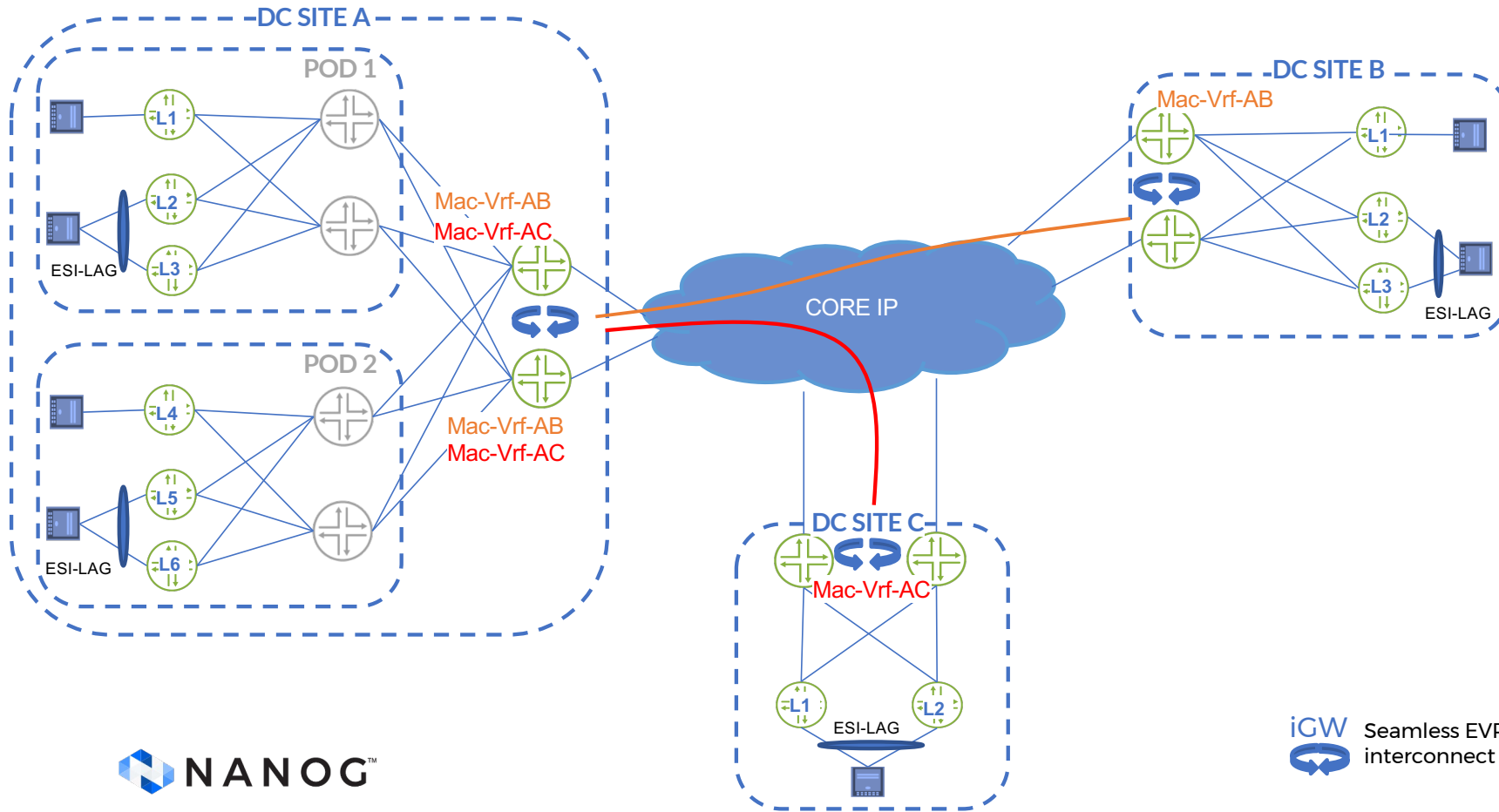

iGW Seamless EVPN-VxLAN stitching  
interconnect gateway

# Type-2 to Type-2 EVPN-VXLAN stitching implementation example inside MAC-VRF (EVI)

```
macvrfAB-vlan-aware {  
  instance-type mac-vrf;  
  protocols {  
    evpn {  
      encapsulation vxlan;  
      default-gateway no-gateway-community;  
      extended-vni-list [ 5055 5056 ];  
      interconnect {  
        vrf-target target:1:55;  
        route-distinguisher 172.16.7.11:55;  
        esi {  
          00:00:99:99:99:99:55:55;  
          all-active;  
        }  
        interconnected-vni-list [ 6055 ];  
      }  
    }  
  }  
  vtep-source-interface lo0.0;  
  service-type vlan-aware;  
  route-distinguisher 172.16.7.11:155;  
  vrf-target target:1:155;  
  vlans {  
    vlan55 {  
      vlan-id 55;  
      vxlan {  
        vni 5055;  
        translation-vni 6055;  
      }  
    }  
    vlan56 {  
      vlan-id 56;  
      vxlan {  
        vni 5056;  
      }  
    }  
  }  
}
```

New tunnel stitching configuration block

VNI translation specific to interconnect function



# Type-5 to Type-5 EVPN-VXLAN stitching implementation example inside Type-5 IP VRF

```
root@border-leaf1> show configuration routing-instances T5-VRF1
```

```
instance-type vrf;  
routing-options {  
  static {  
    route 10.10.100.113/32 discard;  
  }  
  multipath;  
}  
protocols {  
  evpn {  
    interconnect {  
      vrf-target target:102:102;  
      route-distinguisher 172.16.7.113:102;  
    }  
    ip-prefix-routes {  
      advertise direct-nexthop;  
      encapsulation vxlan;  
      vni 1100;  
      export my-t5-export-vrf1;  
    }  
  }  
}  
interface lo0.1;  
route-distinguisher 172.16.7.113:100;  
vrf-target target:1100:1100;  
vrf-table-label;
```

```
root@border-leaf1>
```



```
root@border-leaf2> show configuration routing-instances T5-VRF1
```

```
instance-type vrf;  
routing-options {  
  static {  
    route 10.10.100.114/32 discard;  
  }  
  multipath;  
}  
protocols {  
  evpn {  
    interconnect {  
      vrf-target target:102:102;  
      route-distinguisher 172.16.7.114:102;  
    }  
    ip-prefix-routes {  
      advertise direct-nexthop;  
      encapsulation vxlan;  
      vni 1100;  
      export my-t5-export-vrf1;  
    }  
  }  
}  
interface lo0.1;  
route-distinguisher 172.16.7.114:100;  
vrf-target target:1100:1100;  
vrf-table-label;
```

```
root@border-leaf2>
```

DCI new dedicated block in Type-5 instance

# EVPN-VXLAN stitching – MAC origin and Endpoint type

```
root@border-leaf4> show evpn database instance macvrf101 origin dci-remote
```

```
Instance: macvrf101
```

VLAN	DomainId	MAC address	Active source	Timestamp	IP address
61001		00:00:01:01:01:01	00:00:11:11:11:11:11:11:11:11	Sep 09 11:59:42	10.10.0.1
61001		00:50:56:ab:01:01	00:00:11:11:11:11:11:11:11:11	Sep 09 11:59:42	10.10.0.101
61001		00:50:56:ab:01:02	00:00:11:11:11:11:11:11:11:11		
61001		00:50:56:ab:01:03	00:00:11:11:11:11:11:11:11:11		
61002		00:00:01:01:01:02	00:00:11:11:11:11:11:11:11:11		
61002		c0:03:80:1c:7e:e0	00:00:11:11:11:11:11:11:11:11		
61002		c0:03:80:1c:b5:e0	00:00:11:11:11:11:11:11:11:11	Sep 09 11:59:42	10.10.1.1

All remote-DC MAC@  
behind same remote iESI

Interconnect ESI enabled on remote-site

```
root@border-leaf4>
```

```
root@border-leaf4# run show mac-vrf forwarding vxlan-tunnel-end-point remote summary
```

Logical System Name	Id	SVTEP-IP	IFL	L3-Idx	SVTEP-Mode	ELP-SVTEP-IP	
<default>	0	172.16.7.216	lo0.0	0			
RVTEP-IP	IFL-Idx	Interface	NH-Id	RVTEP-Mode	ELP-IP	Flags	
172.16.7.113	19309	vtep.32773	55058	Wan-VTEP			
172.16.7.114	19308	vtep.32772	55043	Wan-VTEP			
172.16.7.206	19307	vtep.32771	55022	RNVE			
172.16.7.215	19312	vtep.32774	55063	I-ESI-Peer			
RVTEP-IP	L2-RTT	IFL-Idx	Interface	NH-Id	RVTEP-Mode	ELP-IP	Flags
172.16.7.114	macvrf-techfest22	671547396	vtep-56.32772	55043	RNVE		
172.16.7.215	macvrf-techfest22	671547398	vtep-56.32774	55063	I-ESI-Peer		
172.16.7.113	macvrf101	671555589	vtep-57.32773	55058	Wan-VTEP		
172.16.7.114	macvrf101	671555588	vtep-57.32772	55043	Wan-VTEP		
172.16.7.206	macvrf101	671555587	vtep-57.32771	55022	RNVE		
172.16.7.215	macvrf101	671555590	vtep-57.32774	55063	I-ESI-Peer		

shows which VTEP is for DCI

```
[edit]
```

```
root@border-leaf4#
```



## What are the main differences between the T5 and T2 tunnel stitching ?

- Type-5 stitching is not creating local IFL interfaces
- There's no interconnect ESI concept in pure Type-5
- Configuration is done inside the T5 IPVPN instance
- Load balancing is done using IP ECMP overlay in pure Type-5 (aka ipvrf-to-ipvrf / interface-less model – rfc9136)



# Seamless tunnel stitching - D-PATH new BGP attribute



# DCI EVPN & routing loops – problem statement

- EVPN routing loop may occur when routes originated in the interconnect domain are learned back from LAN side and advertised back to the interconnect (WAN) side
- Sub-optimal path forwarding may be created in consequence
- Managing the problem at the community level and policy is too complex to manage from implementation point of view

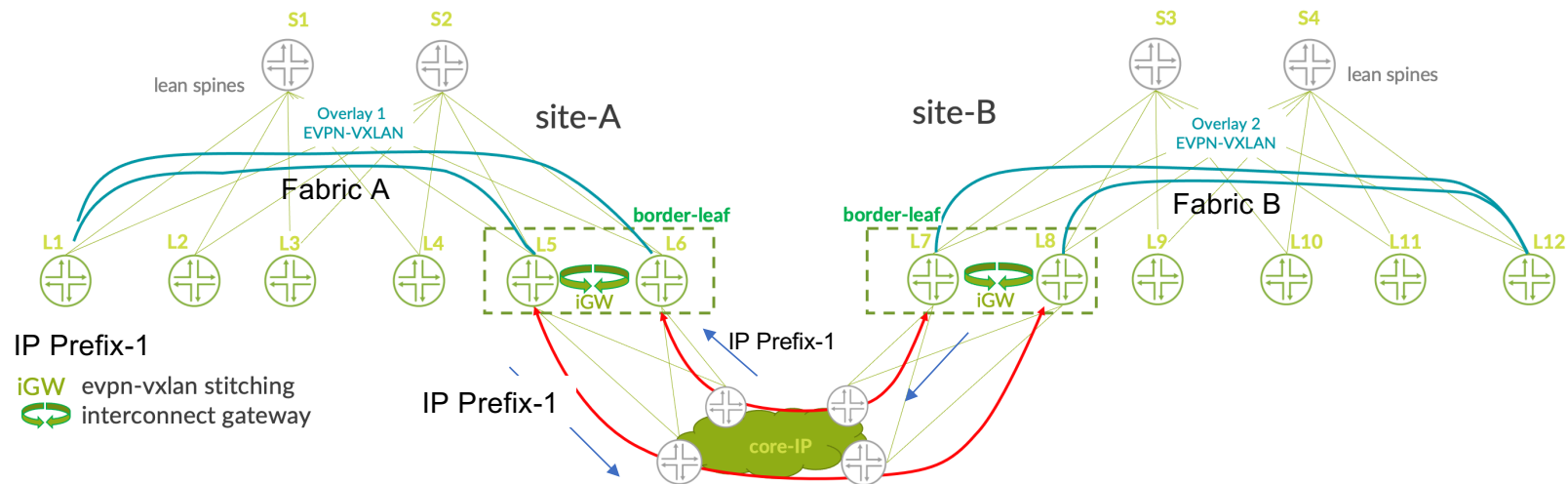

# D-PATH AS A NEW BGP ATTRIBUTE FOR DCI

- 1 All domain IDs included in the D-PATH BGP attribute are compared with the local domain IDs after the route-target verification passed

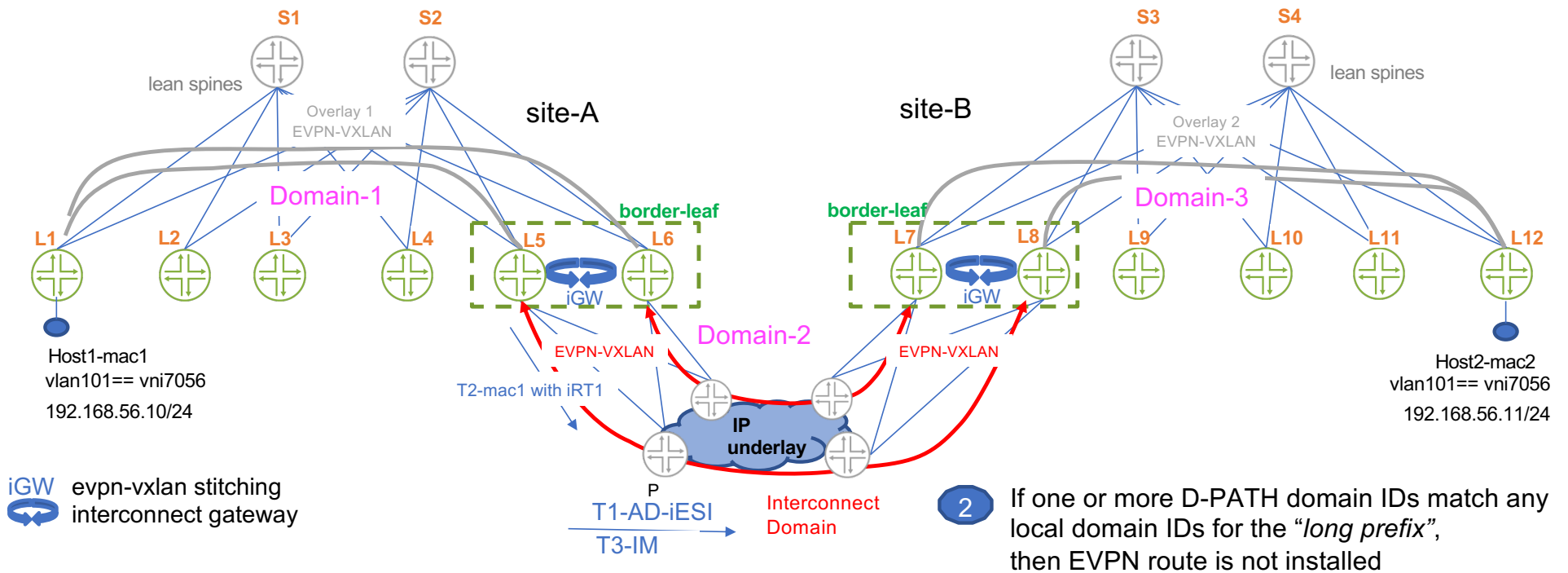

# Seamless tunnel stitching summary notes



# Seamless tunnel stitching – summary notes

- Suitable for L2 and/or L3 DCI and multi-pod designs when LAN Fabric is running EVPN-VXLAN
- Reduces overlay network load – remote site learns DCI routes only
- Improves DC and DCI control – overlay domain creations
- Simplifies day to day operations – pre-established DCI tunnels
- Normalized scale of tunneling – local site gateways next-hops
- Integrated DCI security at the edge of the fabric
  - GBP and flood rate checks at the border-leaf level



# Thank you

 **NANOG™** OCT 18<sup>th</sup> 2022, Hollywood, CA