

Dovetail Series Linear Guide System				
	size (mm x mm)	Load Capacity (lbs)		
		60 PSI	80 PSI	100 PSI
Z direction	150x150	264	352	440
	150x300	528	704	880
Y direction	150x150	228	304	380
	150x300	456	608	760

Dovetail Series Linear Guide System				
	size (mm x mm)	Max Moment (in-lbs)		
		60 PSI	80 PSI	100 PSI
Pitch	150x150	214	285	356
	150x300	712	950	1188
Roll	150x150	243	324	406
	150x300	742	990	1237
Yaw	150x150	105	140	175
	150x300	297	396	495

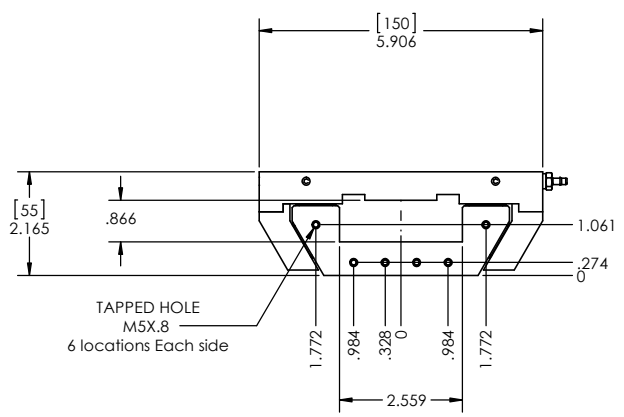
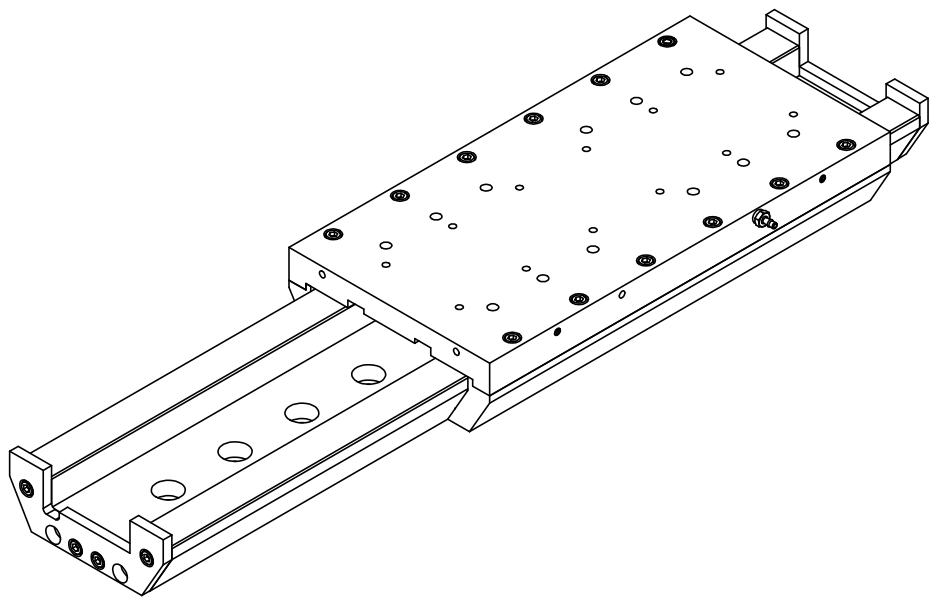
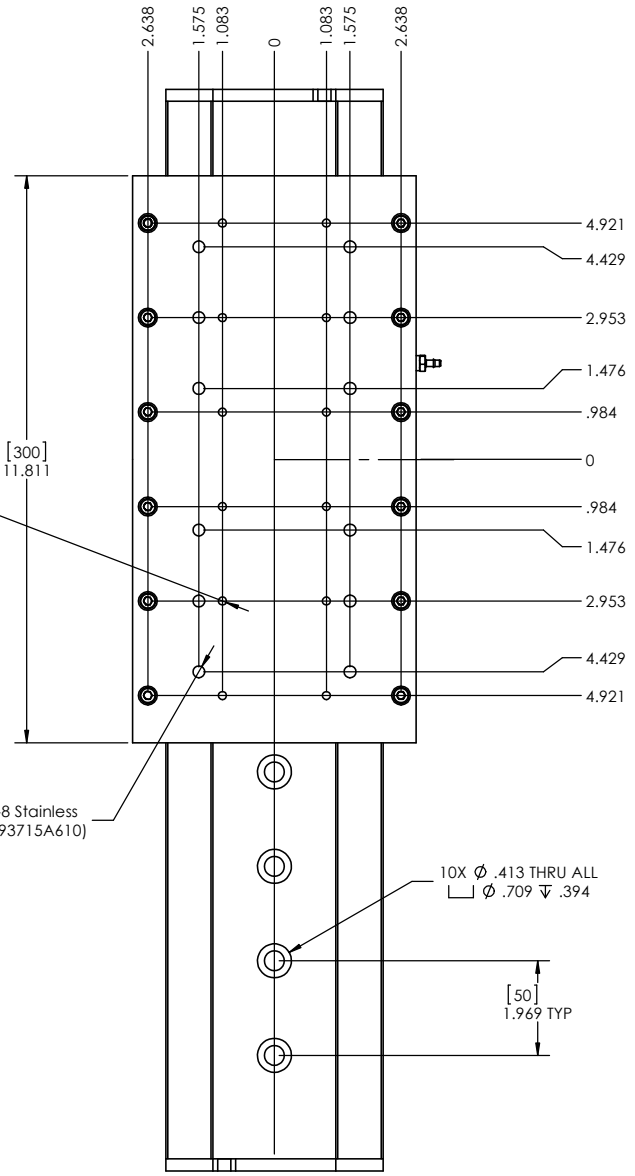

PROPRIETARY AND CONFIDENTIAL
 THE INFORMATION CONTAINED IN THIS DRAWING IS THE SOLE PROPERTY OF <INSERT COMPANY NAME HERE>. ANY REPRODUCTION IN PART OR AS A WHOLE WITHOUT THE WRITTEN PERMISSION OF <INSERT COMPANY NAME HERE> IS PROHIBITED.

		UNLESS OTHERWISE SPECIFIED:		NAME	DATE
		DIMENSIONS ARE IN INCHES			
		TOLERANCES:		DRAWN	
		FRACTIONS: ±		CHECKED	
		ANGULAR: MACH ± BEND ±		ENG APPR.	
		TWO PLACE DECIMAL ±		MFG APPR.	
		THREE PLACE DECIMAL ±		D.A.	
		INTERPRET GEOMETRIC TOLERANCING PER:		COMMENTS:	
		MATERIAL:			
		FINISH:			
		APPLICATION:	DO NOT SCALE DRAWING		

TITLE:		
DOVETAIL SERIES RAIL GUIDE		
SIZE	DWG. NO.	REV
C	DOV-150-300_basic	A
SCALE: 1:2	WEIGHT:	SHEET 1 OF 1