

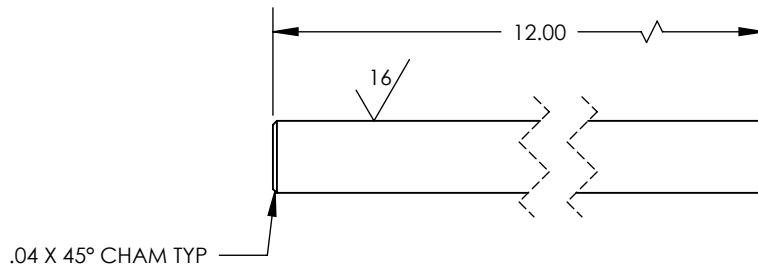

NOTES

- 1) MATERIAL MUST BE 316, 304 OR 304L STAINLESS STEEL PER AMS 5639 OR QQ-S-763.
- 2) 63 SF ALL OVER UNLESS OTHERWISE SPECIFIED
- 3) MUST HAVE STRAIGHTNESS OF .002" PER FOOT MAX

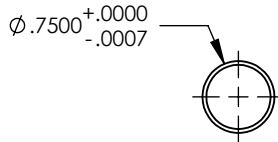
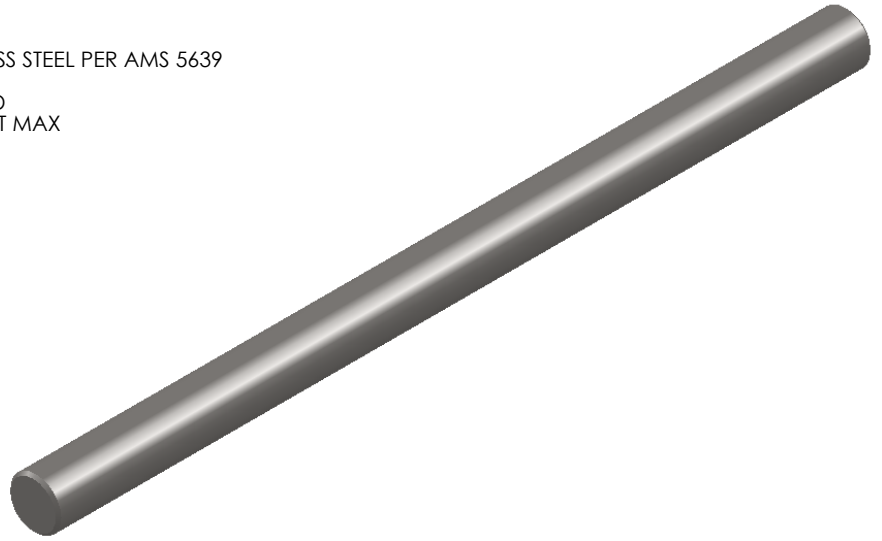

<p>PROPRIETARY AND CONFIDENTIAL</p> <p>THE INFORMATION CONTAINED IN THIS DRAWING IS THE SOLE PROPERTY OF OAVCO . ANY REPRODUCTION IN PART OR AS A WHOLEWITHOUT THE WRITTEN PERMISSION OFOAVCO IS PROHIBITED.</p>			DIMENSIONS ARE IN INCHES TOLERANCES: FRACTIONAL: ANGULAR: $\pm 1/4^\circ$ ONE PLACE DECIMAL $\pm .01$ TWO PLACE DECIMAL $\pm .01$ THREE PLACE DECIMAL $\pm .005$		NAME JT	DATE 8/5/13	 <h2>.75 INC SHAFT</h2>	
			MATERIAL SEE NOTES		CHECKED			SIZE A DWG. NO. OAV0750SHAFT REV.
			FINISH SEE NOTES		ENG APPR.			
			APPLICATION DO NOT SCALE DRAWING		MFG APPR.			
				Q.A.		SCALE:1:2	WEIGHT:	SHEET 1 OF 1