

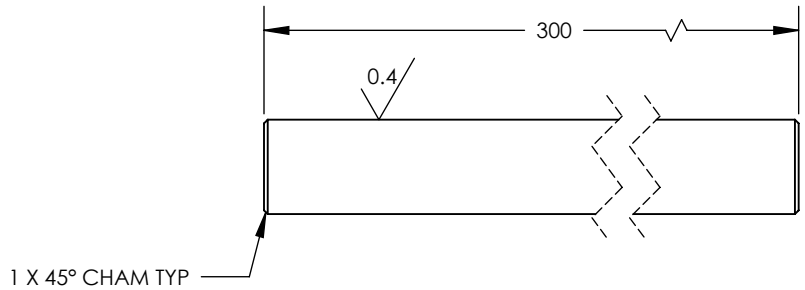

NOTES

- 1) MATERIAL MUST BE 316, 304 OR 304L STAINLESS STEEL PER AMS 5639 OR QQ-S-763.
- 2) 1.6 SF ALL OVER UNLESS OTHERWISE SPECIFIED
- 3) MUST HAVE STRAIGHTNESS OF .03MM PER 300MM MAX

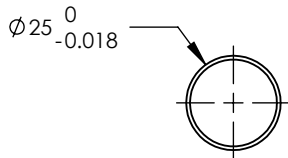
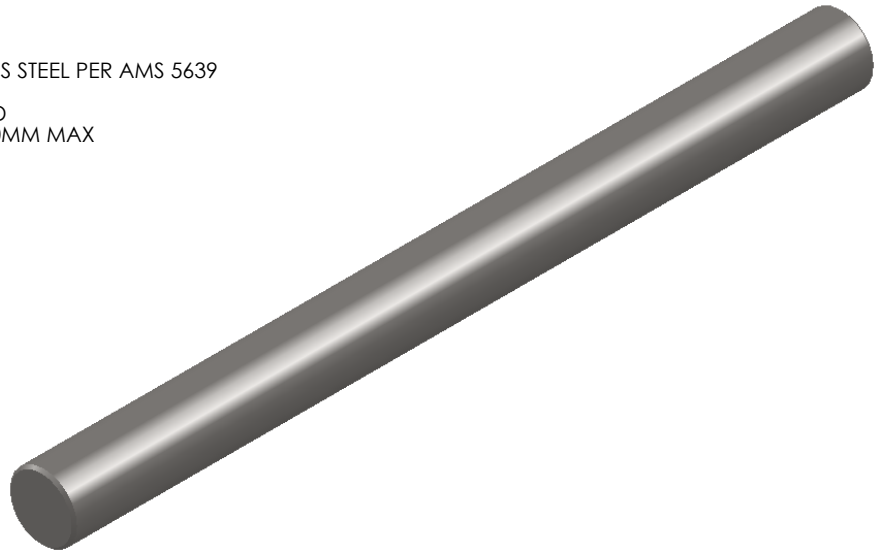

<p><b>PROPRIETARY AND CONFIDENTIAL</b></p> <p>THE INFORMATION CONTAINED IN THIS DRAWING IS THE SOLE PROPERTY OF OAVCO . ANY REPRODUCTION IN PART OR AS A WHOLE WITHOUT THE WRITTEN PERMISSION OF OAVCO IS PROHIBITED.</p>		DIMENSIONS ARE IN MILLIMETERS TOLERANCES: FRACTIONAL: ANGULAR: $\pm 1/4^\circ$ ONE PLACE DECIMAL $\pm .2$ TWO PLACE DECIMAL $\pm .1$		DRAWN JT	DATE 8/5/13	
		MATERIAL SEE NOTES	CHECKED	ENG APPR.	MFG APPR.	
NEXT ASSY	USED ON	FINISH SEE NOTES	COMMENTS:		Q.A.	SIZE DWG. NO. <b>A</b> OAV25MMSHAFT REV.
APPLICATION		DO NOT SCALE DRAWING		SCALE: 1:2	WEIGHT:	