

Title	Specification
Size	0.25 Inch ID
Part Number	OAV0250IB
Housing Material/Finish	7075 Aircraft Quality Aluminum/ Mil Spec Anodize
Input Pressure	40 psi - 100 max psi
Porous Material	Carbon
Pressure Port Threads	M3 X 0.5
Lifetime	infinite
Radial Load Max	2.94 lbs
Radial Stiffness	0.01 lbs/μ in (2 N/μ m)
Pitch Moment Max	0.125 lbs-in (0.013 N-m)
Bushing Inside Diameter (ID)	0.2507 in +.0002in -.0000in
Bushing Outside Diameter (OD)	0.634in +.005in -.000in
Bushing Length	1.250 in
Bushing Weight	11.2 grams
Recommended Shaft Outside Diameter (OD)	0.2500 in - .0007in
Flow Rate	3.00 SCFH

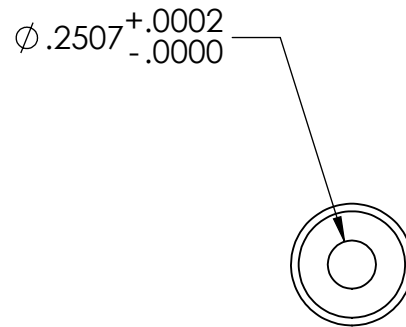

INSTALLATION OPTIONS **A** **B** AND **C**

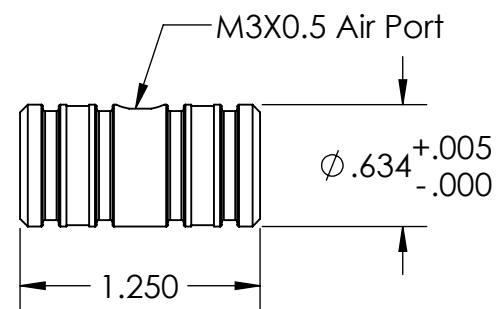
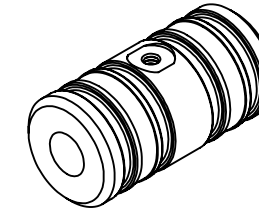
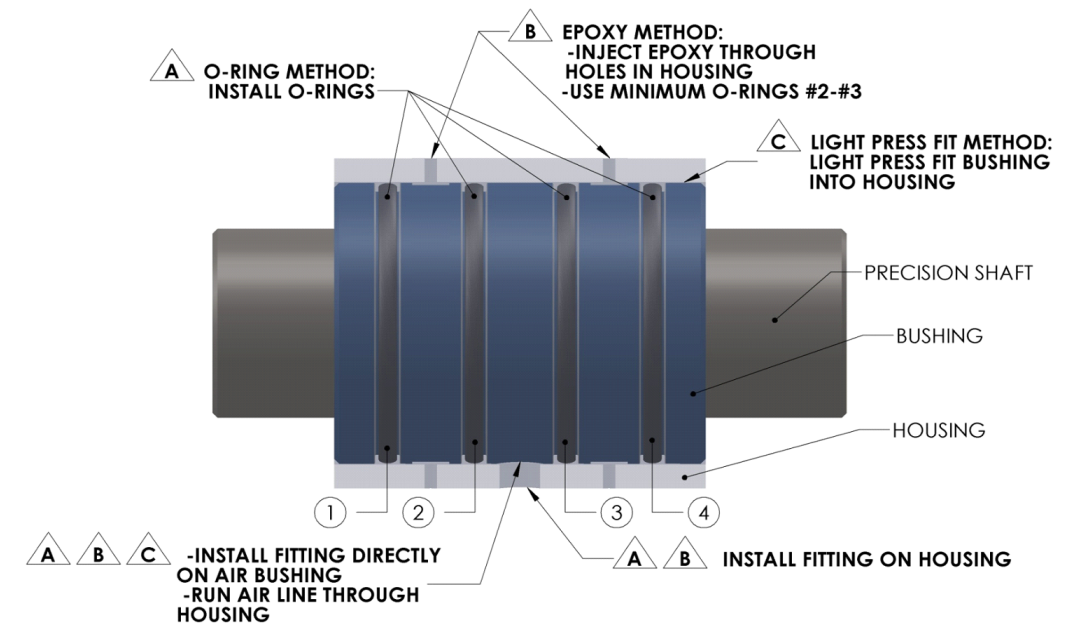

PROPRIETARY AND CONFIDENTIAL
THE INFORMATION CONTAINED IN THIS DRAWING IS THE SOLE PROPERTY OF OAVCO LLC. ANY REPRODUCTION IN PART OR AS A WHOLE WITHOUT THE WRITTEN PERMISSION OF OAVCO LLC IS PROHIBITED.

UNLESS OTHERWISE SPECIFIED:		NAME	DATE
DIMENSIONS ARE IN INCHES		DRAWN	
TOLERANCES:		CHECKED	
FRACTIONAL ±		ENG APPR.	
ANGULAR: MACH ± BEND ±		MFG APPR.	
TWO PLACE DECIMAL ±		Q.A.	
THREE PLACE DECIMAL ±		COMMENTS:	
INTERPRET GEOMETRIC TOLERANCING PER:			
MATERIAL ALUMINUM 7075/ CARBON			
FINISH ANODIZE PER MIL-A-8625			
NEXT ASSY	USED ON		
APPLICATION		DO NOT SCALE DRAWING	

TITLE: .250 INC AIR BUSHING		
SIZE B	DWG. NO. OAV0250IB	REV
SCALE: 1:1	WEIGHT:	SHEET 1 OF 1