

Title	Specification
Size	25 mm ID
Part Number	OAV025MB
Housing Material/Finish	7075 Aircraft Quality Aluminum/ Mil Spec Anodize
Input Pressure	.28 Mpa to .48 max Mpa (40 to 100 PSI)
Porous Material	Carbon
Pressure Port Threads	M3 X 0.5
Lifetime	infinite
Radial Load Max	226.3 N
Radial Stiffness	34 N/μ m (0.19 lbs/μ in)
Pitch Moment Max	1.9 N-m (17 lbs-in)
Bushing Inside Diameter (ID)	25.018mm +.005mm -0mm
Bushing Outside Diameter (OD)	38.91mm +.13mm -0mm
Bushing Length	57.15mm
Bushing Weight	72.0 grams
Recommended Shaft Outside Diameter (OD)	25.00mm - .02mm
Flow Rate	11.78 SCFH

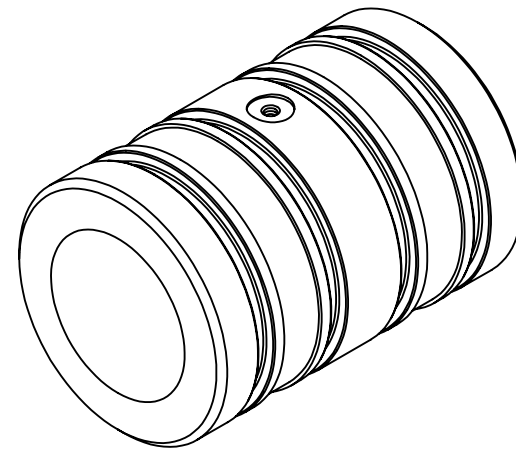

INSTALLATION OPTIONS **A** **B** AND **C**

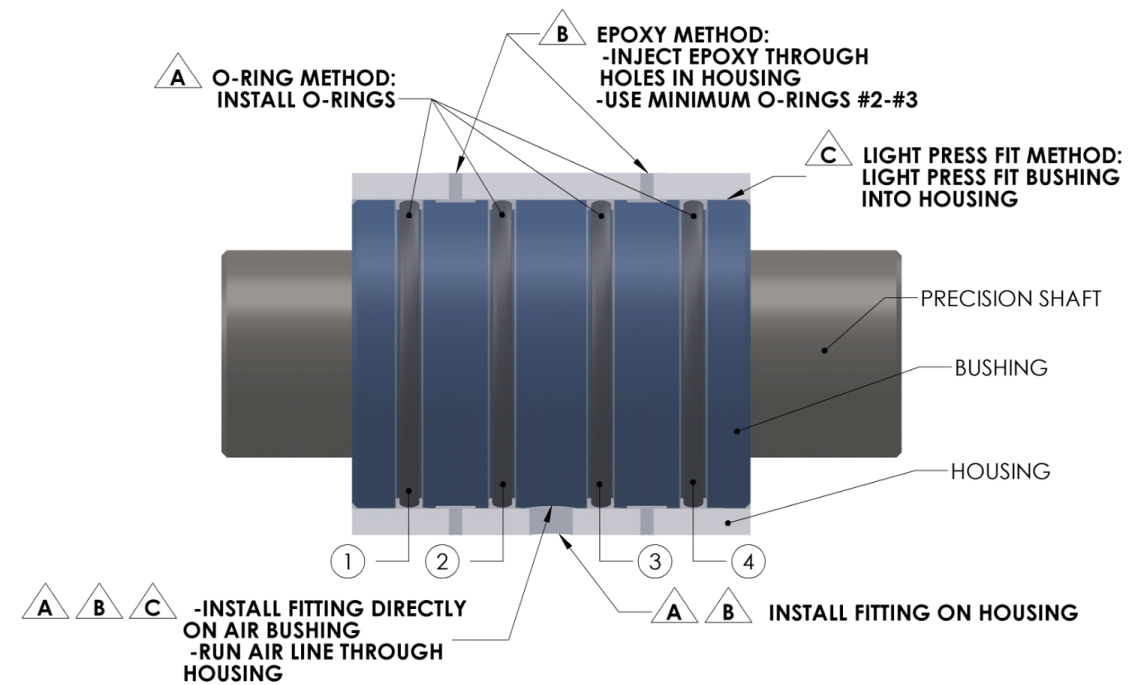
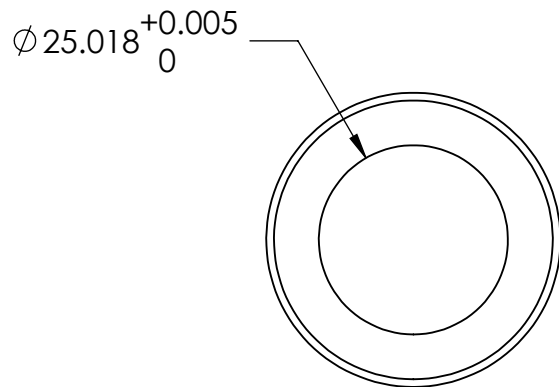
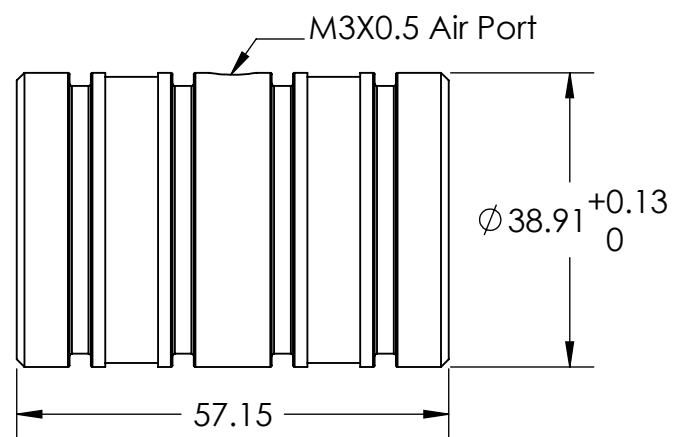

PROPRIETARY AND CONFIDENTIAL
THE INFORMATION CONTAINED IN THIS DRAWING IS THE SOLE PROPERTY OF OAVCO LLC. ANY REPRODUCTION IN PART OR AS A WHOLE WITHOUT THE WRITTEN PERMISSION OF OAVCO LLC IS PROHIBITED.

		UNLESS OTHERWISE SPECIFIED:		NAME	DATE
		DIMENSIONS ARE IN MILLIMETERS		DRAWN	
		TOLERANCES:		CHECKED	
		FRACTIONAL ±		ENG APPR.	
		ANGULAR: MACH ± BEND ±		MFG APPR.	
		TWO PLACE DECIMAL ±		Q.A.	
		THREE PLACE DECIMAL ±		COMMENTS:	
		INTERPRET GEOMETRIC TOLERANCING PER:			
		MATERIAL ALUMINUM 7075/ CARBON			
NEXT ASSY	USED ON	FINISH ANODIZE PER MIL-A-8625			
APPLICATION		DO NOT SCALE DRAWING			
TITLE: 25 MM AIR BUSHING					
SIZE B	DWG. NO. OAV025MB		REV		
SCALE: 1:1		WEIGHT:		SHEET 1 OF 1	