

Size	50mm ID
Part Number	OAVTB100i50
Housing Material/Finish	7075 Aircraft Quality Aluminum
Input Pressure	40 psi - 100 max psi
Porous Material	Carbon
Pressure Port Threads	M5x0.8
Lifetime	infinite
Radial Load Capacity	195.9 lbs (871.4 N)
Thrust Load Capacity	193.8 lbs (862.1 N)
Radial Stiffness	0.63 lbs/μ in (110 N/μ m)
Pitch Moment Max	46 lbs-in (5.2 N-m)
Bushing Inside Diameter (ID)	50.018mm +.005mm - .000mm
Bushing Outside Diameter (OD)	99.49mm +.13mm - .00mm
Bushing Length	91.40mm
Bushing Weight	1237.9g
Recommended Shaft Outside Diameter (OD)	50mm - .02mm

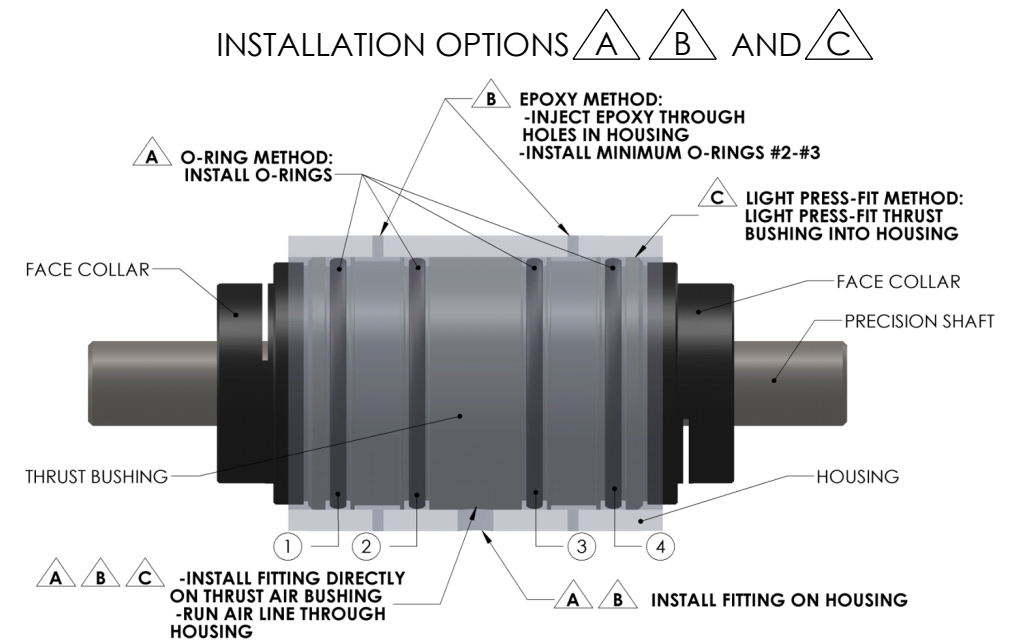
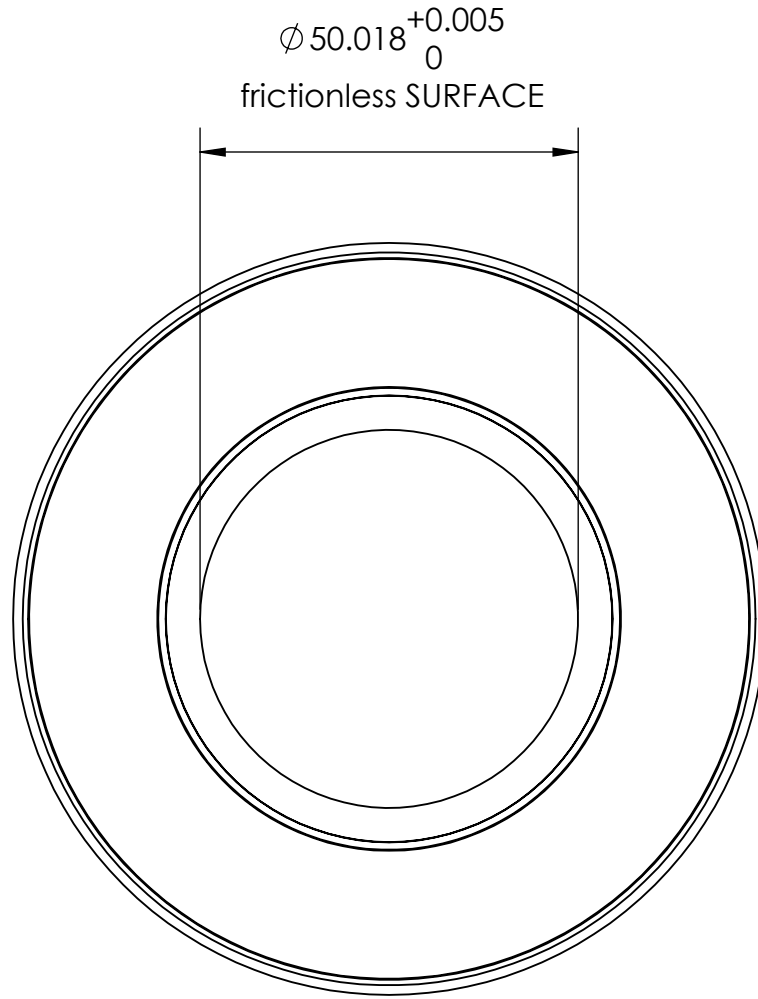
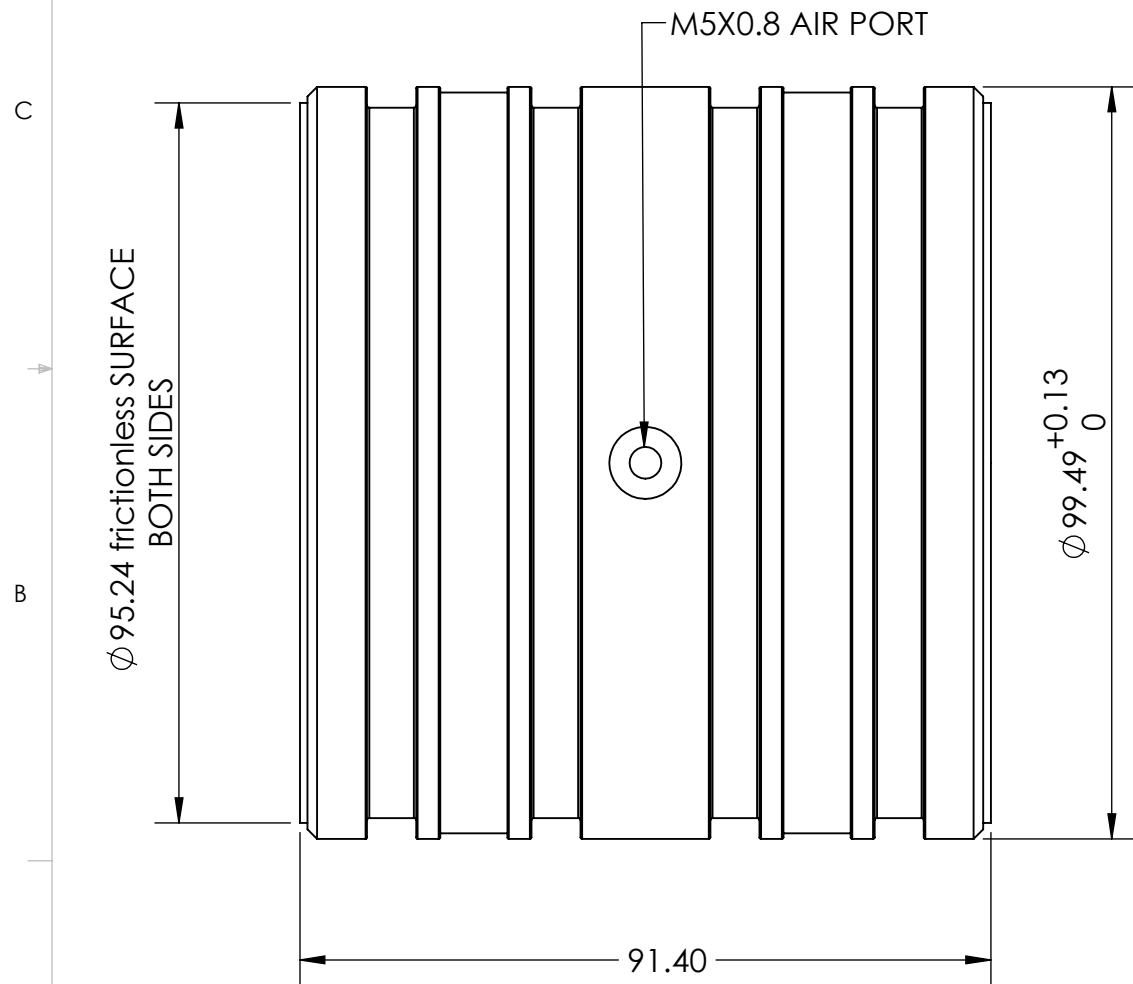

PROPRIETARY AND CONFIDENTIAL
THE INFORMATION CONTAINED IN THIS DRAWING IS THE SOLE PROPERTY OF OAVCO LLC. ANY REPRODUCTION IN PART OR AS A WHOLE WITHOUT THE WRITTEN PERMISSION OF OAVCO LLC IS PROHIBITED.

		UNLESS OTHERWISE SPECIFIED:		NAME		DATE	
		DIMENSIONS ARE IN MILLIMETERS		DRAWN			
		TOLERANCES:		CHECKED			
		FRACTIONAL ±		ENG APPR.			
		ANGULAR: MACH ± BEND ±		MFG APPR.			
		TWO PLACE DECIMAL ±		Q.A.			
		THREE PLACE DECIMAL ±		COMMENTS:			
		INTERPRET GEOMETRIC TOLERANCING PER:					
		MATERIAL					
		FINISH					
NEXT ASSY	USED ON						
APPLICATION		DO NOT SCALE DRAWING					
				TITLE:			
				50MM 3-WAY THRUST BUSHING			
SIZE	DWG. NO.			REV			
B	OAVTB100i50						
SCALE: 1:1		WEIGHT:		SHEET 1 OF 1			