

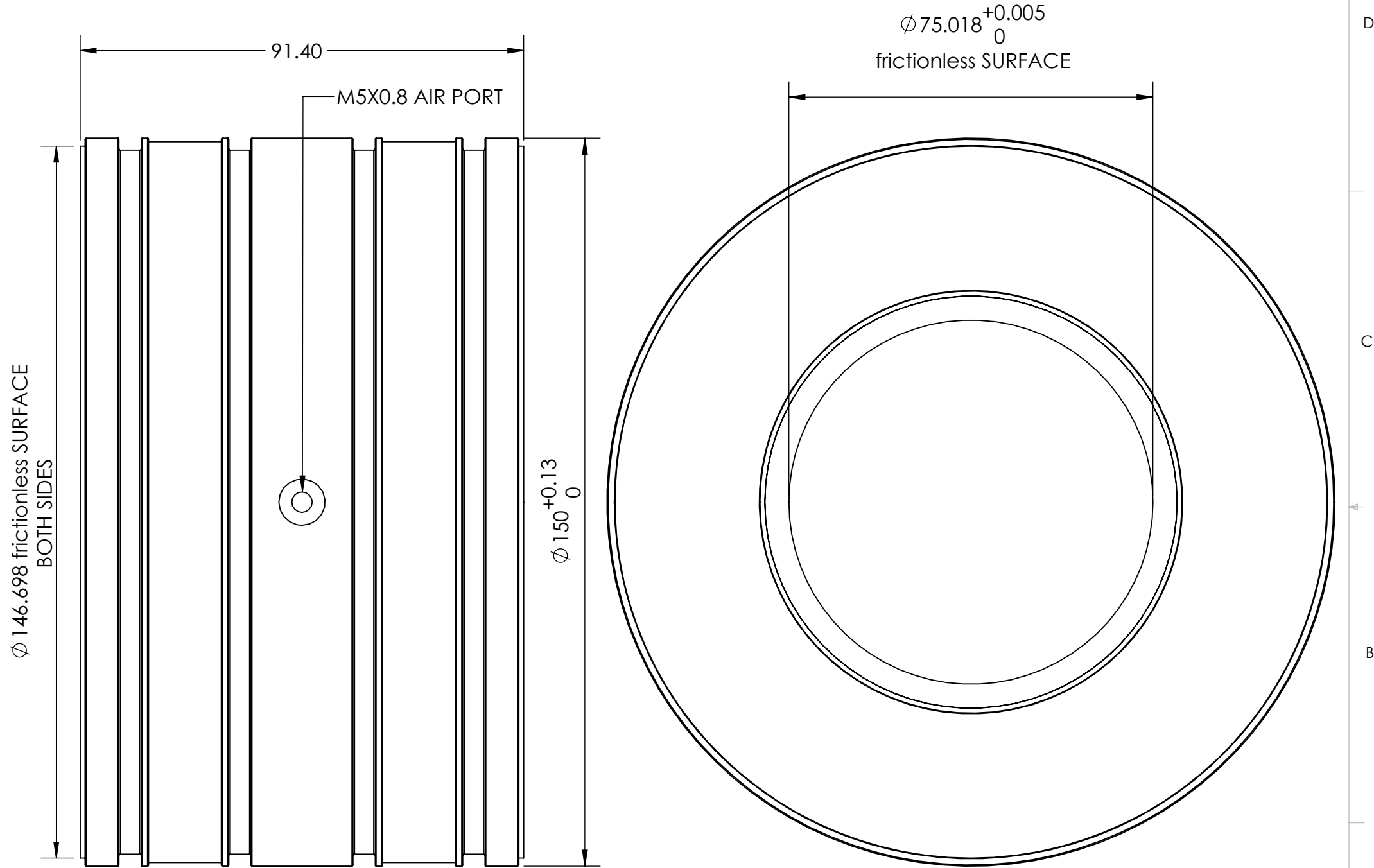

Size	75mm ID
Part Number	OAVTB150i75
Housing Material/Finish	7075 Aircraft Quality Aluminum
Input Pressure	40 psi - 100 max psi
Porous Material	Carbon
Pressure Port Threads	M5x0.8
Lifetime	infinite
Radial Load Capacity	293.8 lbs (1306.9 N)
Thrust Load Capacity	498.0 lbs (2215.2 N)
Radial Stiffness	0.91 lbs/μ in (159 N/μ m)
Pitch Moment Max	63 lbs-in (7.1 N-m)
Bushing Inside Diameter (ID)	75.018mm +.005mm - .000mm
Bushing Outside Diameter (OD)	150.00mm +.13mm - .00mm
Bushing Length	91.40mm
Bushing Weight	2899.9g
Recommended Shaft Outside Diameter (OD)	75mm - .02mm

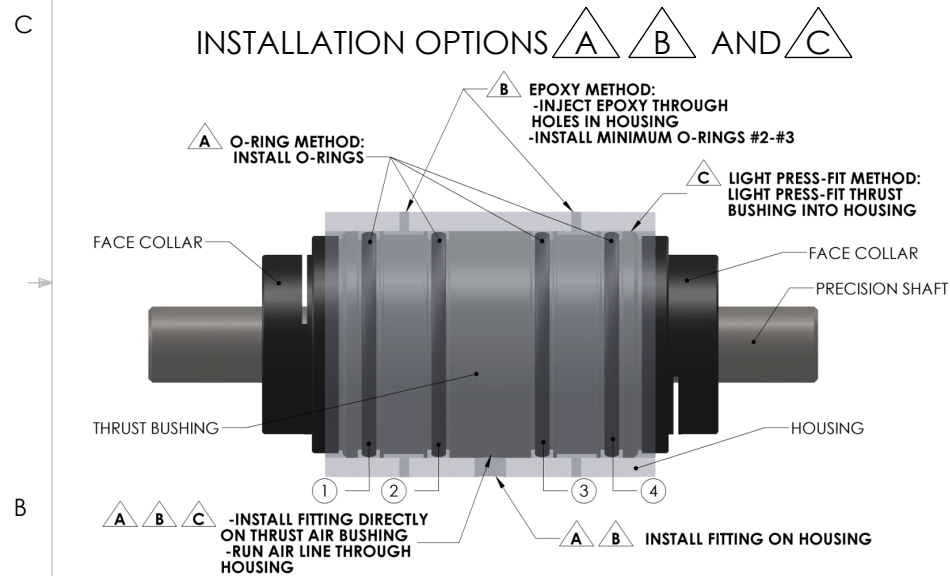

PROPRIETARY AND CONFIDENTIAL
THE INFORMATION CONTAINED IN THIS DRAWING IS THE SOLE PROPERTY OF OAVCO LLC. ANY REPRODUCTION IN PART OR AS A WHOLE WITHOUT THE WRITTEN PERMISSION OF OAVCO LLC IS PROHIBITED.

UNLESS OTHERWISE SPECIFIED:		NAME	DATE
DIMENSIONS ARE IN MILLIMETERS		DRAWN	
TOLERANCES:		CHECKED	
FRACTIONAL ±		ENG APPR.	
ANGULAR: MACH ± BEND ±		MFG APPR.	
TWO PLACE DECIMAL ±		Q.A.	
THREE PLACE DECIMAL ±		COMMENTS:	
INTERPRET GEOMETRIC TOLERANCING PER:			
MATERIAL			
FINISH			
NEXT ASSY	USED ON		
APPLICATION			
DO NOT SCALE DRAWING			



TITLE:
75MM 3-WAY THRUST BUSHING

SIZE B	DWG. NO. OAVTB150i75	REV
SCALE: 1:1	WEIGHT:	SHEET 1 OF 1