

Housing Material/Finish	7075 Aircraft Quality Aluminum
Input Pressure	.28 Mpa to .68 max Mpa
Porous Material	Carbon
Pressure Port Threads	M3 X 0.5
Lifetime	infinite
Radial Load Max	2.1 lb (9.34)N
Thrust Load Max	3.6 lb (16.01)N
Radial Stiffness	5 N/μ m (0.03 lbs/μ in)
Pitch Moment Max	.125 lbs-in (0.013N/μ-m)
Thrust Bushing Inside Diameter (ID)	4.018mm +.005mm -.000mm
Thrust Bushing Outside Diameter (OD)	16.1mm +.13mm -.00mm
Bushing Length	33mm
Bushing Weight	13.8 grams
Recommended Shaft Outside Diameter (OD)	4.00mm - .01mm

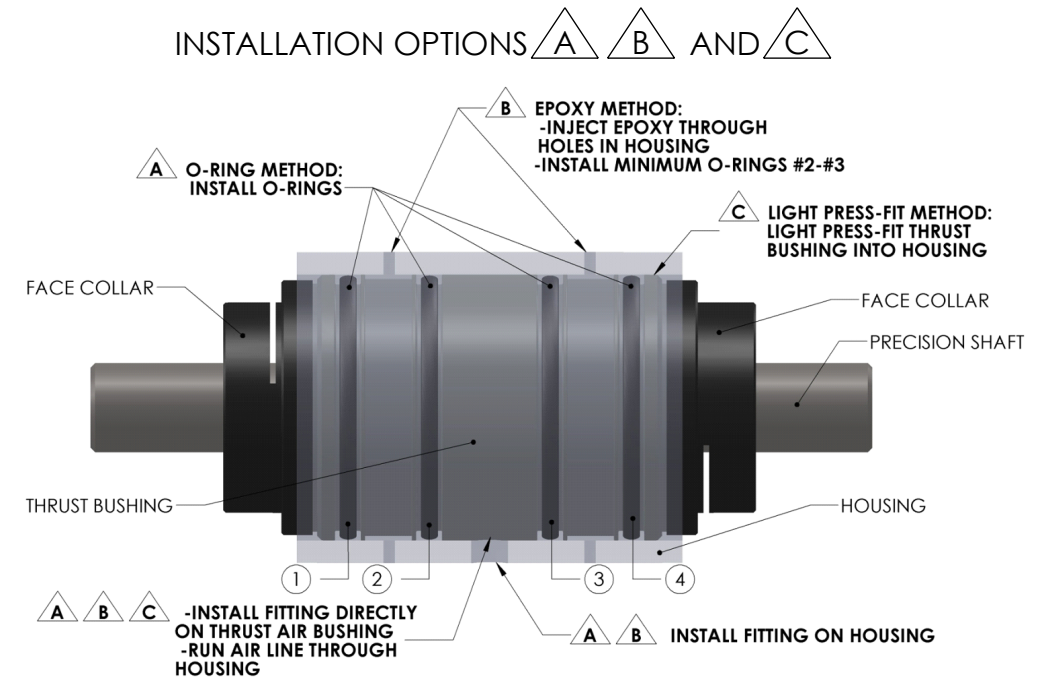
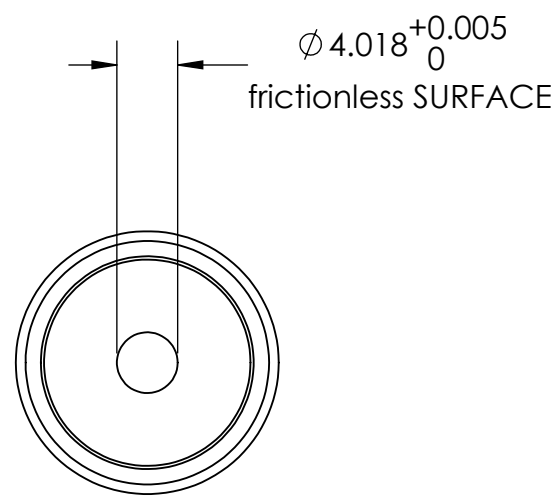
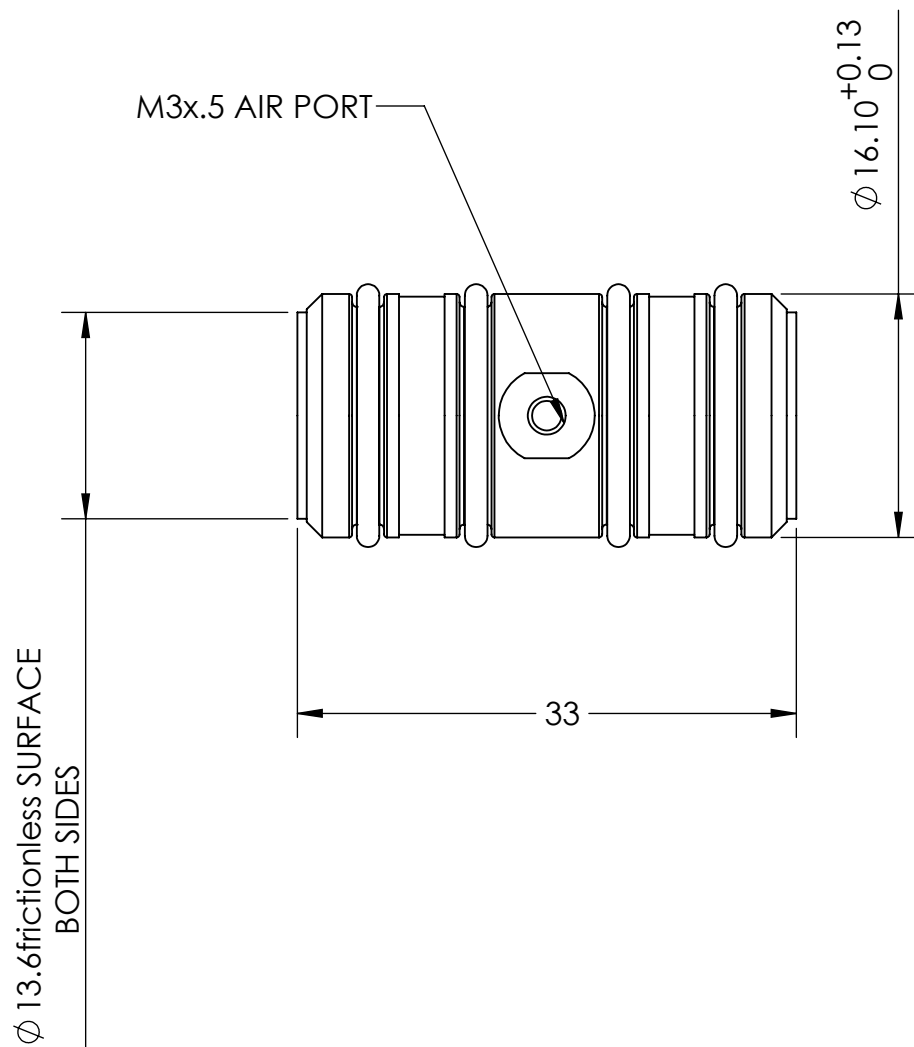

PROPRIETARY AND CONFIDENTIAL
 THE INFORMATION CONTAINED IN THIS DRAWING IS THE SOLE PROPERTY OF OAVCO LLC. ANY REPRODUCTION IN PART OR AS A WHOLE WITHOUT THE WRITTEN PERMISSION OF OAVCO LLC IS PROHIBITED.

UNLESS OTHERWISE SPECIFIED:		NAME	DATE
DIMENSIONS ARE IN MILLIMETERS		DRAWN	
TOLERANCES:		CHECKED	
FRACTIONAL ±		ENG APPR.	
ANGULAR: MACH ± BEND ±		MFG APPR.	
TWO PLACE DECIMAL ±		Q.A.	
THREE PLACE DECIMAL ±		COMMENTS:	
INTERPRET GEOMETRIC TOLERANCING PER:			
MATERIAL			
FINISH			
NEXT ASSY	USED ON		
APPLICATION		DO NOT SCALE DRAWING	

TITLE: 4MM 3-WAY THRUST BUSHING		
SIZE B	DWG. NO. OAVTB16i04	REV
SCALE: 1:1	WEIGHT:	SHEET 1 OF 1