

Size	20mm ID
Part Number	OAVTB60i20
Housing Material/Finish	7075 Aircraft Quality Aluminum
Input Pressure	40 psi - 100 max psi
Porous Material	Carbon
Pressure Port Threads	M5 X 0.8
Lifetime	infinite
Radial Load Capacity	54.9 lbs (240.2 N)
Thrust Load Capacity	84 lbs (373.7 N)
Radial Stiffness	0.13 lbs/μ in (23 N/μ m)
Pitch Moment Max	10 lbs-in (1.1 N-m)
Bushing Inside Diameter (ID)	20.018mm +.005mm -.000mm
Bushing Outside Diameter (OD)	59.59mm +.13mm -.00mm
Bushing Length	79.20mm
Bushing Weight	465 g
Recommended Shaft Outside Diameter	20mm - .02mm

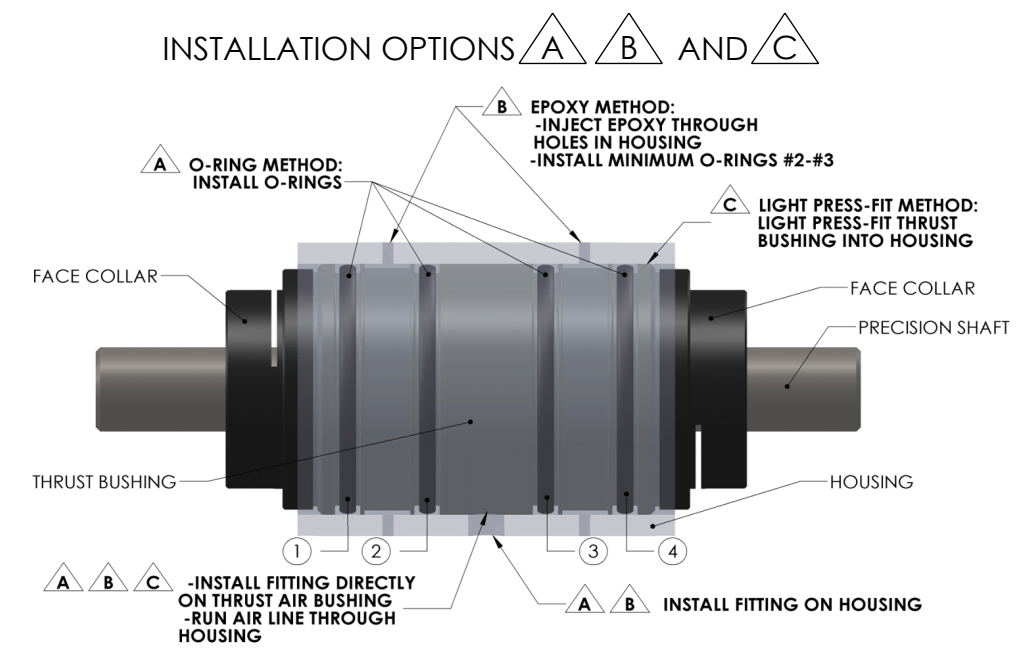
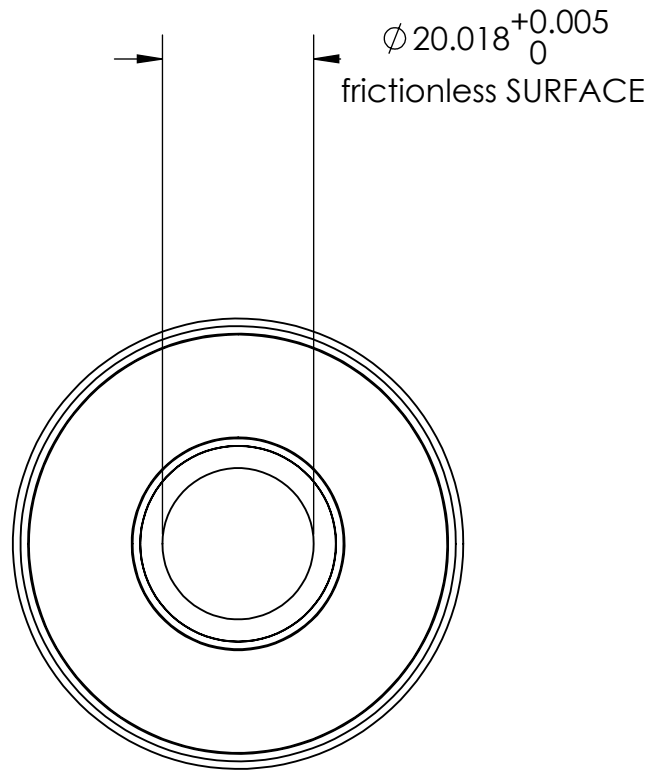
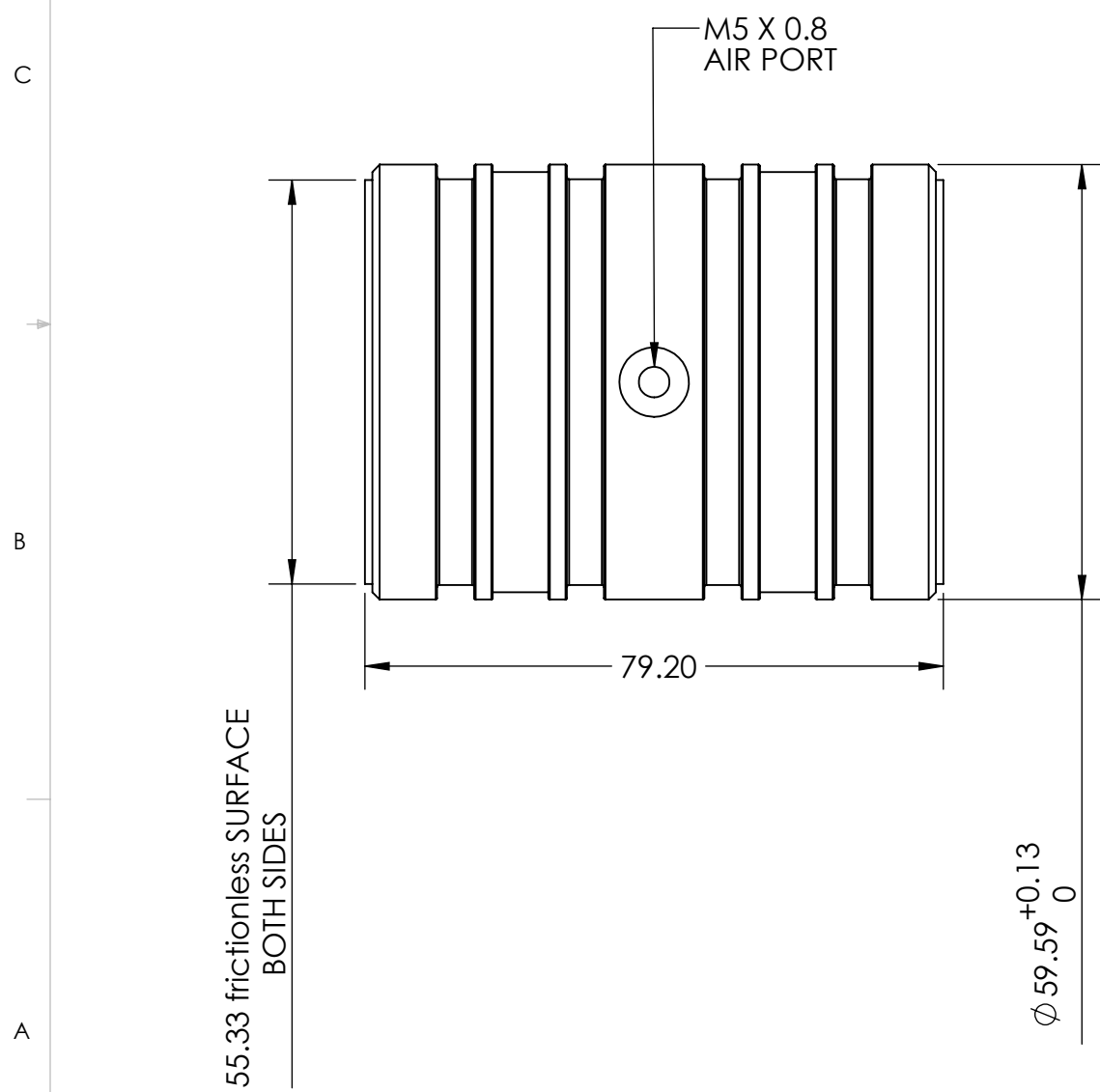

PROPRIETARY AND CONFIDENTIAL
THE INFORMATION CONTAINED IN THIS DRAWING IS THE SOLE PROPERTY OF OAVCO LLC. ANY REPRODUCTION IN PART OR AS A WHOLE WITHOUT THE WRITTEN PERMISSION OF OAVCO LLC IS PROHIBITED.

UNLESS OTHERWISE SPECIFIED:		NAME	DATE
DIMENSIONS ARE IN MILLIMETERS		DRAWN	
TOLERANCES:		CHECKED	
FRACTIONAL ±		ENG APPR.	
ANGULAR: MACH ± BEND ±		MFG APPR.	
TWO PLACE DECIMAL ±		Q.A.	
THREE PLACE DECIMAL ±		COMMENTS:	
INTERPRET GEOMETRIC TOLERANCING PER:			
MATERIAL			
FINISH			
NEXT ASSY	USED ON		
APPLICATION		DO NOT SCALE DRAWING	

TITLE: 20MM 3-WAY THRUST BUSHING		
SIZE B	DWG. NO. OAVTB60i20	REV
SCALE: 1:1	WEIGHT:	SHEET 1 OF 1