

CANDIDATE  
NAME

--

CENTRE  
NUMBER

--	--	--	--	--

CANDIDATE  
NUMBER

--	--	--	--



**BUSINESS**

**9609/32**

Paper 3 Case Study

**February/March 2019**

**3 hours**

Candidates answer on the Question Paper.

No Additional Materials are required.

**READ THESE INSTRUCTIONS FIRST**

Write your centre number, candidate number and name in the spaces at the top of this page. If you need additional answer paper ask the invigilator for a continuation booklet.

Write in dark blue or black pen.

You may use an HB pencil for any diagrams, graphs or rough working.

Do not use staples, paper clips, glue or correction fluid.

DO **NOT** WRITE IN ANY BARCODES.

**Section A**

Answer **all** questions.

**Section B**

Answer **one** question.

You are advised to spend no more than 40 minutes on Section B.

Refer to the Insert for the case study for this Paper.

At the end of the examination, fasten all your work securely together.

The number of marks is given in brackets [ ] at the end of each question or part question.

This document consists of **19** printed pages, **1** blank page and **1** Insert.





2 (a) Refer to the network diagram in Fig. 1 and to Table 2 in the Insert.

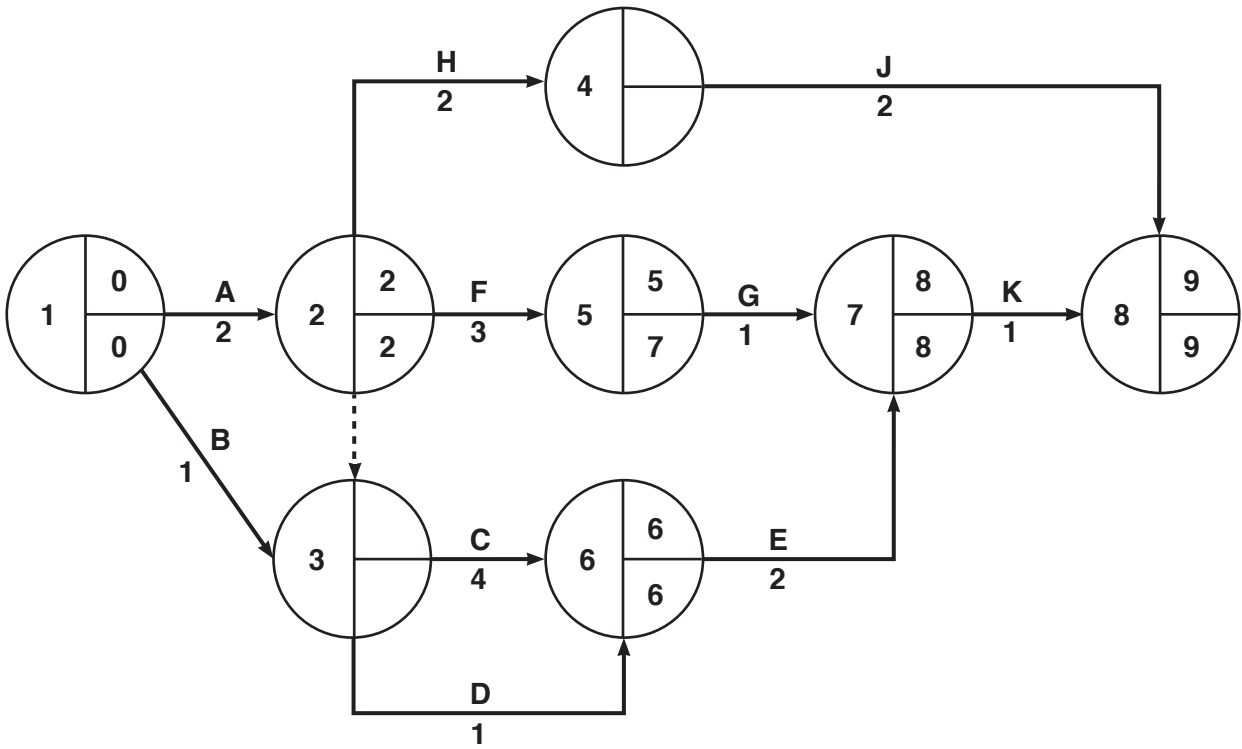

Fig. 1: Network diagram for opening new café

(i) Complete the network diagram at nodes 3 and 4. [4]

(ii) State the activities on the critical path.  
 .....  
 ..... [1]

(iii) State the minimum time to complete the opening of the new café.  
 .....  
 ..... [1]

(iv) Calculate the free float of Activity F.  
 .....  
 .....  
 ..... [2]











4 (a) Refer to Appendix 1. Calculate:

(i) seasonal variation in 2018 Quarter 1

.....  
.....  
..... [1]

(ii) average seasonal variation in Quarter 2.

.....  
.....  
.....  
.....  
.....  
..... [2]

(b) Refer to Appendix 1 and Appendix 2. Calculate PY's forecast sales for Quarter 3 in 2019.

.....  
.....  
.....  
.....  
.....  
.....  
.....  
.....  
..... [3]







A series of horizontal dotted lines for writing, consisting of 25 lines spaced evenly down the page.







A series of 25 horizontal dotted lines spanning the width of the page, intended for writing.



**BLANK PAGE**

---

Permission to reproduce items where third-party owned material protected by copyright is included has been sought and cleared where possible. Every reasonable effort has been made by the publisher (UCLES) to trace copyright holders, but if any items requiring clearance have unwittingly been included, the publisher will be pleased to make amends at the earliest possible opportunity.

To avoid the issue of disclosure of answer-related information to candidates, all copyright acknowledgements are reproduced online in the Cambridge Assessment International Education Copyright Acknowledgements Booklet. This is produced for each series of examinations and is freely available to download at [www.cambridgeinternational.org](http://www.cambridgeinternational.org) after the live examination series.

Cambridge Assessment International Education is part of the Cambridge Assessment Group. Cambridge Assessment is the brand name of the University of Cambridge Local Examinations Syndicate (UCLES), which itself is a department of the University of Cambridge.