

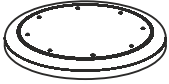

STOOL ASSEMBLY INSTRUCTION

Stool Parts Include The Following:

1. Seat Pan



2. Leg (A)

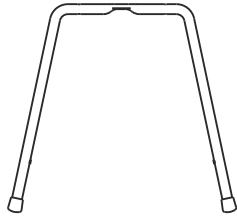

3. Leg (B)

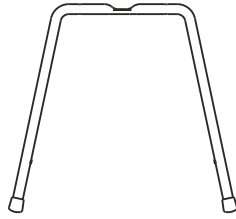

4. Footring

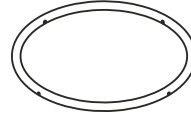

5. Screw (M5x20)

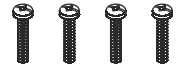

6. Screw (M5x30)



STEP 1: Fixing Legs

- Place seat pan on flat surface as shown
- Affix leg (A) using 2 screws (M5x20mm)
- Affix leg (B) using 2 screws (M5x20mm)

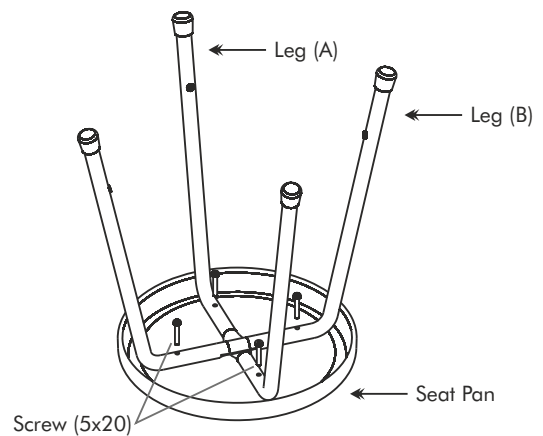

STEP 2: Fixing Footring

- Position footring so that its holes are aligned with holes in legs
- Affix 4 screws (M5x30mm)

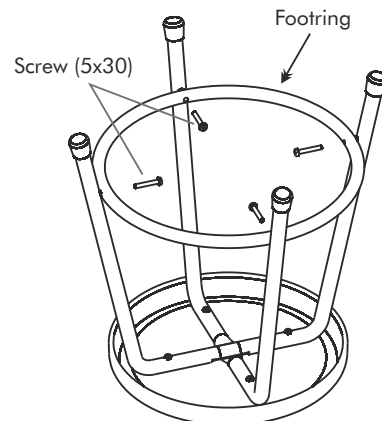

STEP 3:

Flip stool into upright position

THE STOOL IS READY TO USE.

Manufactured for/ Hecho para / Fabrique pour Alera®/ Essendant Co.
One Parkway North, Deerfield, IL 60015 © 2019 Essendant Co.
Made in/ Hecho en / Fabrique en India

Product support and parts:
Ayuda del producto y partes: 1-800-733-4000
Support technique et pieces:

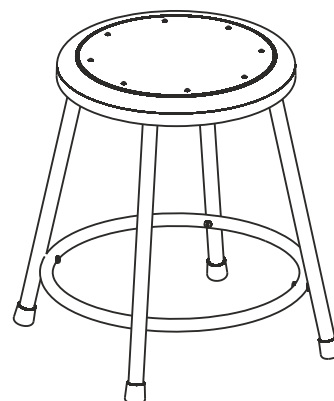



INSTRUCCIONES DE ENSAMBLAJE DEL TABURETE

Las piezas de taburete incluyen lo siguiente:

1. Platillo de asiento



2. Pata (A)

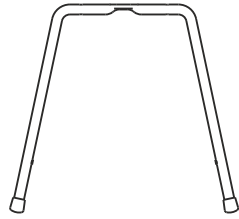

3. Pata (B)

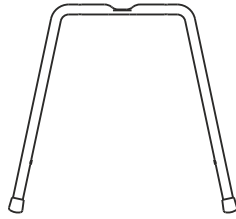

4. Aro de apoyo para pies

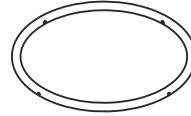

5. Tornillo (M5x20)



6. Tornillo (M5x30)



PASO 1: Fijación de las patas

- Coloque el platillo de asiento sobre una superficie plana tal como se muestra
- Fije la pata (A) utilizando 2 tornillos (M5x20mm)
- Fije la pata (B) utilizando 2 tornillos (M5x20mm)

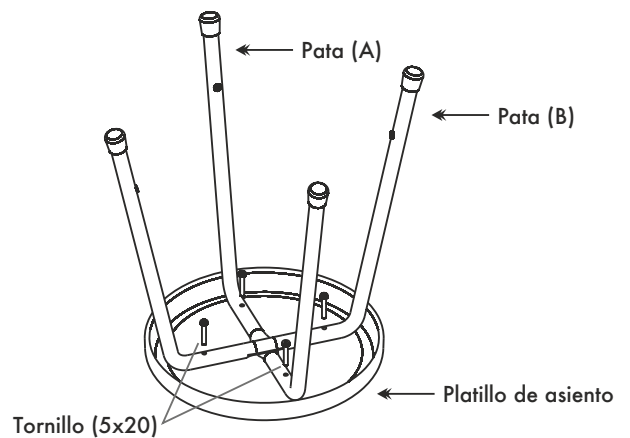

PASO 2: Fijación del aro de apoyo para pies

- Coloque el aro de apoyo para pies de modo que sus orificios estén alineados con los orificios de las patas
- Fije 4 tornillos (M5x30mm)

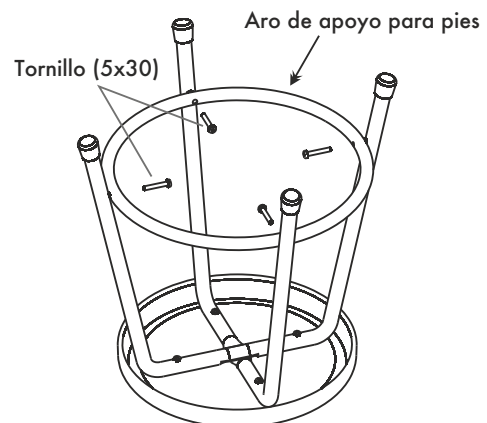

PASO 3:

Voltee el taburete hasta la posición vertical

EL TABURETE ESTÁ LISTO PARA USAR.

Manufactured for/ Hecho para / Fabrique pour Alera®/ Essendant Co.
One Parkway North, Deerfield, IL 60015 © 2019 Essendant Co.
Made in/ Hecho en / Fabrique en India

Product support and parts:
Ayuda del producto y partes: 1-800-733-4000
Support technique et pieces:

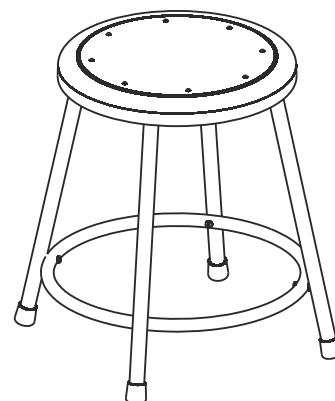



INSTRUCTIONS DE MONTAGE DE TABOURET

Le tabouret est constitué de ces pièces:

1. Plateau de siège

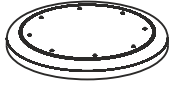

2. Pied (A)

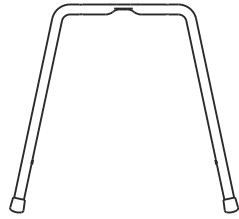

3. Pied (B)

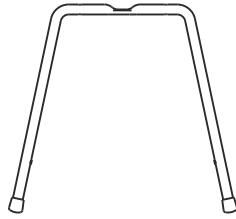

4. Anneau de pieds

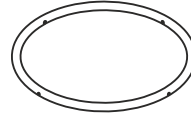

5. Vis (M5x20)

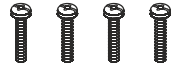

6. Vis (M5x30)



ÉTAPE 1: Fixation des pieds

- Placez le plateau de siège sur une surface plane comme c'est montré
- Fixez le pied double (A) à l'aide de 2 vis (M5 x 20 mm)
- Fixez le pied double (B) à l'aide de 2 vis (M5 x 20 mm)

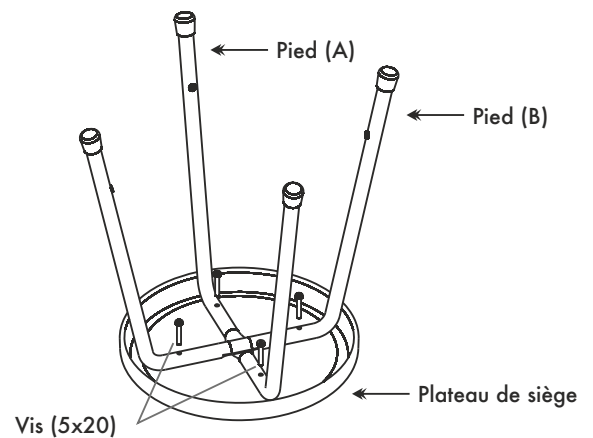

ÉTAPE 2: Fixation de l'anneau de pieds

- Positionnez l'anneau afin que ses trous soient alignés avec ceux des pieds
- Fixez-le avec 4 vis (M5 x 30 mm)

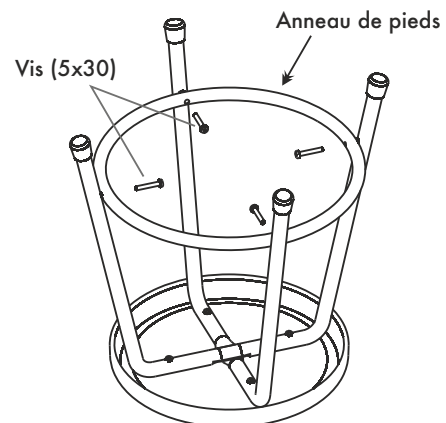

ÉTAPE 3:

Remettez le tabouret à l'endroit

CE TABOURET EST PRÊT À L'EMPLOI.

Manufactured for/ Hecho para / Fabrique pour Alera®/ Essendant Co.
One Parkway North, Deerfield, IL 60015 © 2019 Essendant Co.
Made in/ Hecho en / Fabrique en India

Product support and parts:
Ayuda del producto y partes: 1-800-733-4000
Support technique et pieces:

