



SL Series
Nesting/stacking chairs without arms
AAP-SL651

Save This Manual For Future Reference

DESCRIPTION

- 250 pound capacity
- Stacks up to 12 high for space saving storage
- Folds for easy, nesting storage
- 17 $\frac{1}{8}$ " W x 16 $\frac{1}{2}$ " D seat and 20 $\frac{1}{2}$ " W x 11 $\frac{5}{8}$ " H back
- Welded frame assures strength and stability
- Powder coated steel frame is 1 $\frac{1}{16}$ " by $\frac{5}{8}$ " thick

GENERAL SAFETY INSTRUCTIONS

1. Do not stand on seat.
2. Chair must be on level surface to ensure proper stability.
3. Only use chair when fully assembled.
4. Periodically check fasteners and tighten securely if needed.
5. Never use chair if it does not perform according to this manual.
6. Warranty may be void if chair is used while damaged. Immediately call 1-800-733-4000 and report any problems.

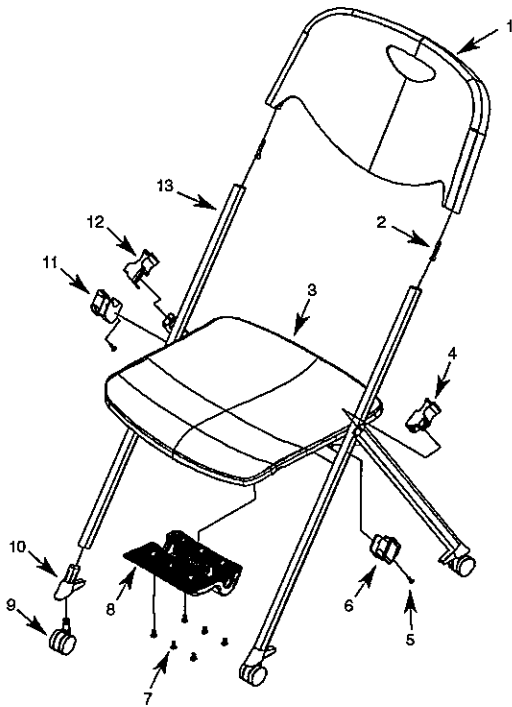

PARTS LIST

KEY NO.	DESCRIPTION	QTY	PART NO.
1	Back	1	10480.00
2	Back Connector	2	10481.00
3	Seat	1	10482.00
4	Left Ganging Connector	1	10477.00
5	¼-20 x ½" Truss Head Screw	2	10483.00
6	Left Stacking Cap	1	10484.00
7	¼-20 x ½" Flat Head Screw	6	10485.00
8	Nesting Mechanism	1	10486.00
9	Caster	4	10475.00
10	Glide	4	10487.00
11	Right Stacking Cap	1	10488.00
12	Right Ganging Connector	1	10476.00
13	Frame (not available as a repair part)	1	N/A



LIMITED 5-YEAR WARRANTY

Except as otherwise provided within this Limited Warranty, United Stationers Supply Co. ("USSCo") will repair or replace any Alera Plus™ and other USSCo branded furniture products, component or part that is found by USSCo to be defective in material or workmanship within five (5) years from the date of original purchase so long as you, the original purchaser, still owns it. This is your sole and exclusive remedy. This warranty is subject to the provisions below. It applies to products sold within the United States of America and the Commonwealth of Canada.

Limitations:

- Fabric, vinyl and/or leather is warranted for two (2) years from the date of original purchase of the chair by the original owner of the Alera Plus™ product in question.

Exclusions:

This warranty does not apply and no other warranty applies to:

- Normal wear and tear, which are to be expected over the course of ownership.
- Modifications or attachments to the product that are not approved by USSCo.
- Products that were not installed, used or routinely and properly maintained in accordance with product instructions and warnings.
- Products used for rental purposes.

Color variations in fabrics and finishes:

USSCo does not warrant the color-fastness or matching of colors, grains or textures of covering materials.

TO THE EXTENT ALLOWED BY LAW, USSCo DISCLAIMS ALL OTHER WARRANTIES, EITHER EXPRESS OR IMPLIED, INCLUDING ANY WARRANTY OF MERCHANTABILITY OR FITNESS FOR A PARTICULAR PURPOSE. USSCo WILL NOT BE LIABLE FOR ANY CONSEQUENTIAL OR INCIDENTAL DAMAGES.

Notice to Purchasers for home or personal use:

Federal law does not permit the exclusion of certain implied warranties for consumer products. Therefore, if you are purchasing this product for home or personal use, the exclusion of implied warranties noted in the above paragraph does not apply to you. Some states do not allow the exclusion or limitation of incidental or consequential damages, so the above limitation or exclusion may not apply to you. This warranty gives you specific legal rights, and you may also have other rights which vary from state to state.

To obtain service under this warranty:

Your Alera Plus™ Reseller will work with USSCo in supporting your warranty requests. Please note: Written authorization of USSCo must be obtained before any warranty work is performed. To obtain authorization and to ensure the best level of customer service, please take the following steps:

1. If a defect is discovered, please contact the Reseller from whom the product was purchased within 30 days from the date of discovery. The Reseller will require information about the product such as: the SKU number, serial number and/or registration number or date of manufacture from the product in question and/or any original transaction documents affirming that you are the original purchaser of this product.
2. Following your claim, your Reseller will conduct an inspection and review. During this time your Reseller or their appointed servicing agent will gather information regarding the claim, inspect the product and contact a USSCo customer service representative. Please allow a reasonable amount of time for these activities.
3. A customer service representative or another representative of USSCo will determine whether to provide replacement parts, authorize repairs or replace the product providing USSCo affirms that the product in question is eligible under the conditions of the warranty as stated above.