



CLEANING AND CARE OF YOUR FURNITURE

THIS FURNITURE IS MANUFACTURED WITH A HIGH QUALITY MELAMINE LAMINATE FINISH AND DURABLE PVC EDGING. IT IS HIGHLY RESISTANT TO COMMON HAZARDS SUCH AS SCRATCHES, PEELING, DENTS, MOISTURE AND HEAT. DURING THE MANUFACTURING PROCESS SOME GLUE RESIDUE MAY BE LEFT ON THE PANELS. THIS IS NORMAL, AND THIS RESIDUE CAN BE EASILY REMOVED WITH A SOFT CLOTH MOISTENED WITH ISOPROPYL (RUBBING ALCOHOL). FOR REGULAR MAINTENANCE OF YOUR FURNITURE USE A SOFT CLOTH WITH A MILD CLEANING SOLUTION. NEVER USE ABRASIVES OR HARSH CHEMICALS.

LIMPIEZA Y CUIDADO DE SU MUEBLE

ESTE MUEBLE ESTA HECHO CON MADERA LAMINADA DE ALTA CALIDAD, CON CANTOS DURABLES DE PVC, ES TOTALMENTE RESISTENTE A RAYONES, GOLPES, HUMEDAD Y CALOR. DURANTE EL PROCESO DE FABRICACION PODRIAN QUEDAR PEQUEÑOS RESTOS DE PEGAMENTO EN LOS PANELES. ESTOS RESIDUOS SON FACILMENTE REMOVIBLES CON UN PAÑO SUAVE HUMECTADO CON ALCOHOL. PARA EL MANTENIMIENTO REGULAR DE ESTE MUEBLE, USE UN PAÑO SUAVE CON UNA SOLUCION NO AGRESIVA. NUNCA UTILICE PRODUCTOS QUIMICOS FUERTES NI ABRASIVOS.

**EASY ASSEMBLY
RTA**
No tools required

Assembles
in less
than **10** minutes

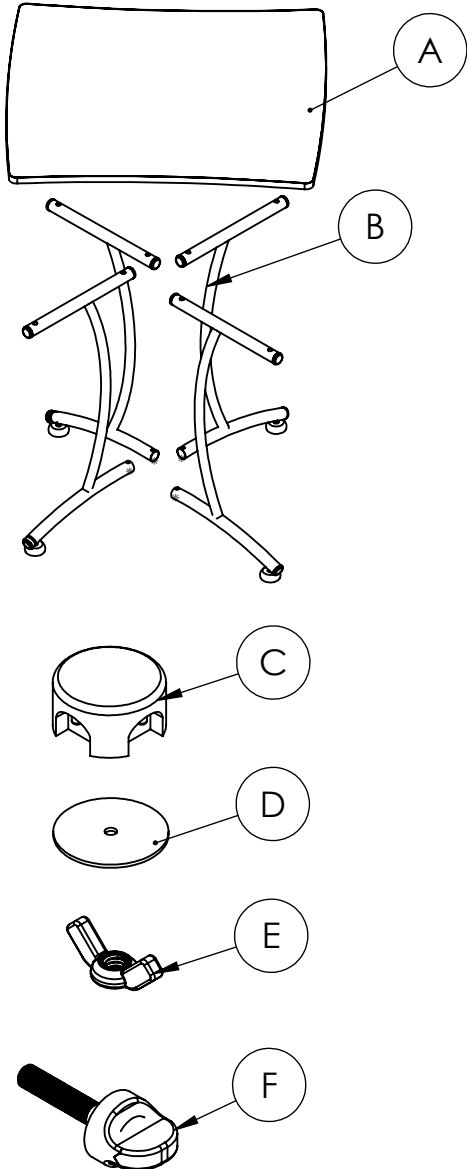

PART/PIEZA	QTY/CANT	ITEM/DESCRIPCIÓN
A	1	TOP PANEL/ Cubierta superior
B	4	LEGS/Patas
C	1	LEG SUPPORT KNOB/Base para patas
D	1	SUPPORT PLATE/Placa de soporte
E	1	WING NUT /Mariposa
F	8	40 MM KNOB/Regaton 40 mm

1
1

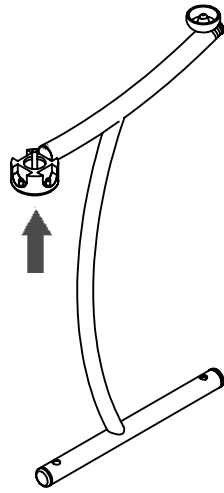

INSERT ONE LEG HOLE INTO LEG SUPPORT KNOB PIN
INSERTE EL BARRENO DE LA PATA EN EL PIN DEL SOPORTE PLASTICO

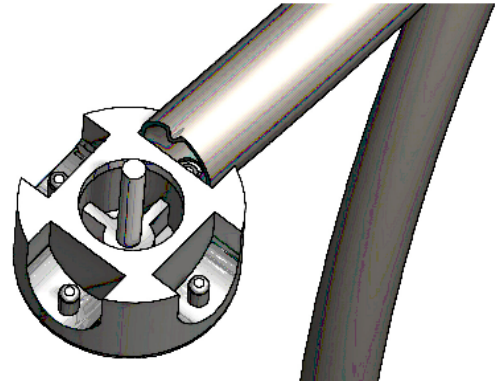

2
2

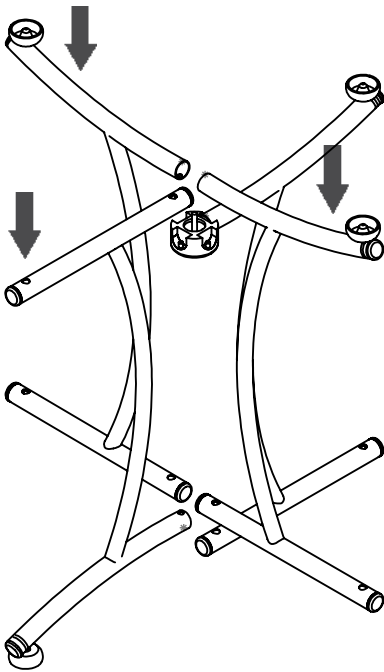

INSERT OTHER LEGS HOLES INTO LEG SUPPORT KNOB PIN
UNA VEZ ARMADA LA PRIMER PATA, PROCEDA A INSERTAR LAS RESTANTES EN EL SOPORTE PLASTICO

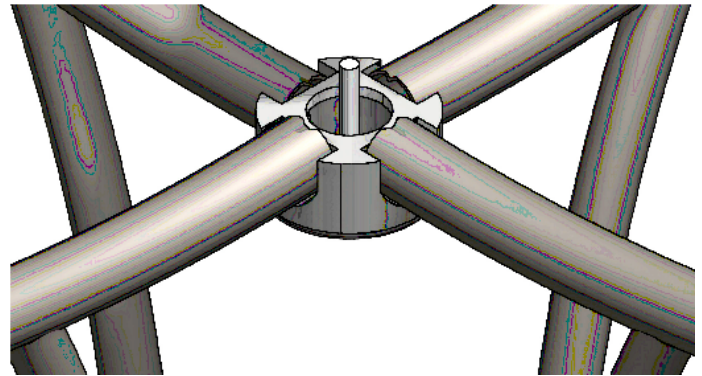

3
3

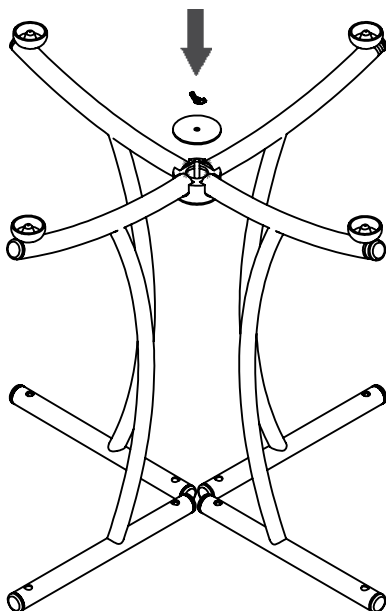

INSTALL SUPPORT PLATE USING WING NUT: TIGHTEN WELL.
INSTALACION DE PLACA DE SOPORTE USANDO LA MARIPOSA; APRIETE FUERTE.

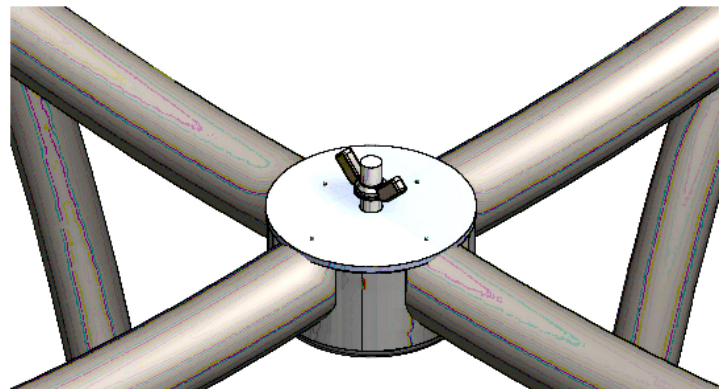

4

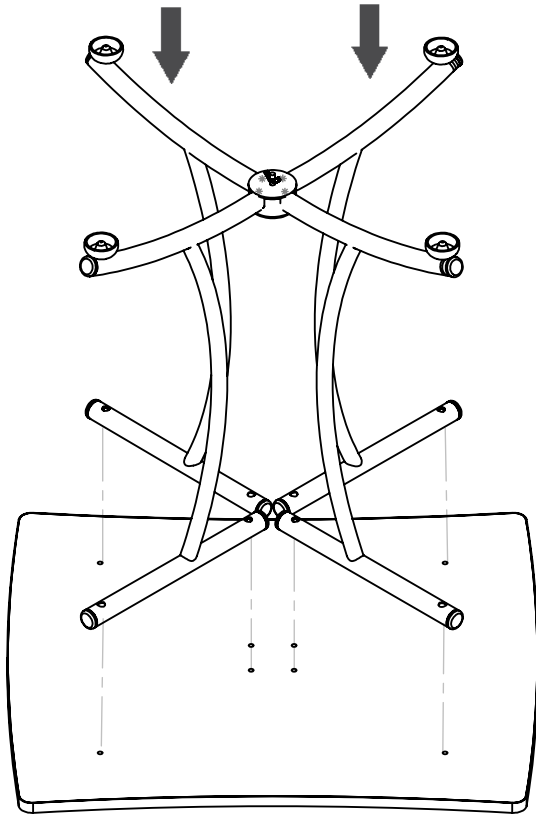

PLACE LEG ASSEMBLY ONTO TOP ALIGNING HOLES OF LEGS WITH TOP INSERTS

COLOQUE LAS PATAS ARMADAS SOBRE LA CUBIERTA SUPERIOR ALINIE LOS BARRENOS CON LOS INSERTO.

5

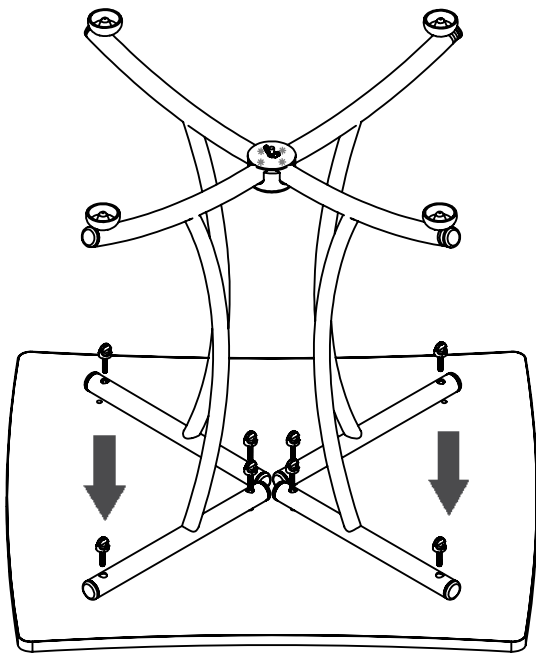

SCREW KNOBS LOOSELY INTO EACH LEG AND TABLE HOLE. TIGHTEN COMPLETELY TO FINISH.

INSTALE LOS REGATONES Y APRIETE LIGERAMENTE HASTA QUE ESTEN BIEN ALINEADOS, APRIETE TODOS UNA VEZ TODOS QUEDEN ALINEADOS

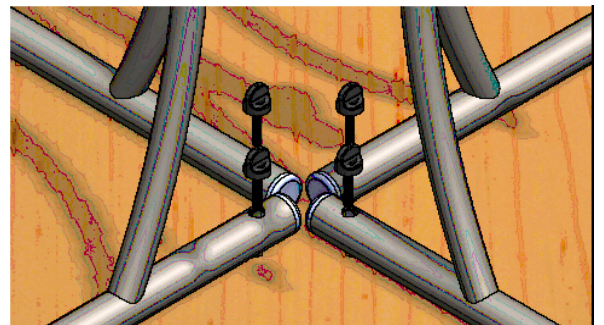

LIMITED 5-YEAR WARRANTY

CREACIONES INDUSTRIALES S.A. DE C.V. (CRISA) WARRANTIES ITS PRODUCTS AGAINST MANUFACTURING, MATERIAL AND WORKMANSHIP DEFECTS TO THE ORIGINAL PURCHASER FROM THE DATE OF PURCHASE FOR A PERIOD OF 5 YEARS. THE WARRANTY IS SUBJECT TO THE PRODUCTS STILL BEING OWNED BY THE ORIGINAL PURCHASER AND INSTALLED, USED AND MAINTAINED IN ACCORDANCE WITH PRODUCT INSTRUCTIONS AND WARNINGS.

WARRANTY DURATION:

■ **5 YEARS:** Desks, hutches, panels and file cabinets

■ **1 YEAR:** Plastic caps, locks, hinges, fabric, casters, wood seats and accessories. Sienna chair A501

LIMITATIONS:

■ Damage caused by the carrier-in-transit is handled under separate terms as defined by the carrier

EXCLUSIONS:

- 1) Damages resulting from improper product installation, assembly or disassembly
- 2) Normal wear and tear as expected over the course of ownership
- 3) Modifications or attachments to the product not approved by CRISA
- 4) Product used for rental purpose

WARRANTY WILL NOT BE APPLICABLE IN THE FOLLOWING CASES:

- 1) Products that were not installed, used or routinely and properly maintained in accordance with product instructions and warnings.
- 7) Product used in different conditions than intended.
 - 1) Product not assembled according to the provided written instructions.
 - 2) Product changed or repaired by non CRISA authorized personnel
 - 3) Defects occurring after the purchase by natural disasters, product modification, intentional damage, accident, misuse, abuse, negligence or exposure to the elements.
 - 4) Damages caused by third party carriers other than Creaciones Industriales S.A DE C.V.

TO THE EXTENT ALLOWED BY LAW, CRISA MAKES NO OTHER WARRANTY, EITHER EXPRESS OR IMPLIED, INCLUDING ANY WARRANTY OF MERCHANTABILITY OR FITNESS FOR A PARTICULAR PURPOSE. CRISA WILL NOT BE LIABLE FOR ANY CONSEQUENTIAL OR INCIDENTAL DAMAGES.

Notice to Purchasers for home or personal use:

Federal law does not permit the exclusion of certain implied warranties for consumer products. Therefore, if you are purchasing this product for home or personal use, the exclusion of implied warranties noted in the above paragraph does not apply to you. Some states do not allow the exclusion or limitation of incidental or consequential damages, so the above limitation or exclusion may not apply to you. This warranty gives you specific legal rights, and you may also have other rights which vary from state to state.

WARRANTY PROCEDURE.

- 1) Your Linea Italia reseller will work with CRISA in supporting your warranty request.
- 2) Defects must be reported immediately when discovered. Please contact the Reseller from whom the product was purchased and provide SKU#, invoice # or date of manufacture from the product.
- 3) Provide a detailed description of the problem with photos, lot number and invoice number. It is important not to remove any labels from the product as they provide important traceability information.
- 4) A customer service representative or CRISA will determine whether to provide replacement parts, authorize repairs or replace the product provided CRISA affirms that the product in question is eligible under the conditions of the warranty as stated above.
- 5) CRISA will review the defect and determine whether it is related to material or workmanship. If the defect is not related to manufacturing, cost of replacement parts and shipping will be the customer's responsibility.

CREACIONES INDUSTRIALES S.A DE C.V. RESERVES THE RIGHT TO CHANGE PRODUCTS, TECHNICAL SPECIFICATIONS, ACCESSORY COMBINATIONS, COLORS, IMAGES AND DATA AT ANY TIME WITHOUT NOTICE.



California 93120

Compliant for Formaldehyde Phase 2

The California Air Resources Board (CARB) approved an Airborne Toxic Control Measure (ATCM) to reduce formaldehyde emissions from composite wood products including hardwood, medium density fiberboard and particleboard. These finished goods are low in formaldehyde emissions and comply with the ATCM.

Creaciones Industriales S.A de C.V

Jose Ma. Chavez N. 643, CP.20000
Aguascalientes, Ags. Mexico