



CLEANING AND CARE OF YOUR FURNITURE

FOR REGULAR MAINTENANCE OF YOUR FURNITURE, USE A SOFT CLOTH WITH A MILD CLEANING SOLUTION. NEVER USE ABRASIVES OR HARSH CHEMICALS TO CLEAN THE FURNITURE AS IT MAY HARM THE FINISH.

LIMPIEZA Y CUIDADO DE SU MUEBLE

PARA REGULAR MANTENIMIENTO DE SUS MUEBLES, UTILICE UN PAÑO SUAVE CON UNA SOLUCIÓN DE LIMPIEZA. NUNCA UTILICE ABRASIVOS NI QUÍMICOS FUERTES PARA LIMPIAR EL MUEBLE YA QUE PODRÍA DAÑAR EL ACABADO.



**EASY ASSEMBLY
RTA
No tools required**

**Assembles
in less
than 10 minutes**

PART/PIEZA	QTY/CANT	ITEM/DESCRIPCION
A	1	POLYCARBONATE DIVIDER WITH SUPPORT/ MINI MAMPARA DE POLICARBONATO CON SOPORTE
B	2	SAFETY KNOB 14.6 mm/ REGATÓN DE SEGURIDAD 14.6 MM

***NOTE:**

-DIVIDER OCCUPIES 3/4" SPACE BEYOND DESK EDGE WHEN INSTALLED

***NOTA:**

-MINI MAMPARA OCUPA 3/4 " DE ESPACIO MÁS ALLA DEL BORDE DEL ESCRITORIO CUANDO ESTA INSTALADO

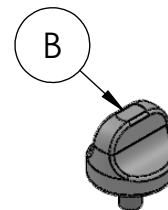
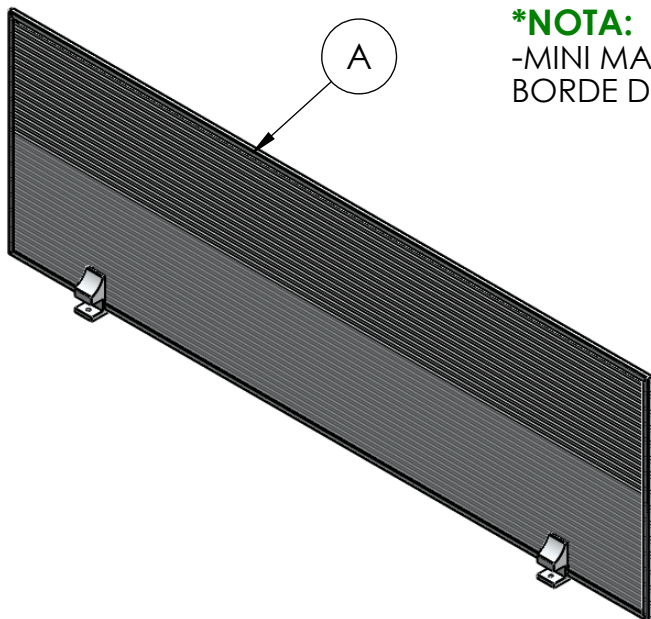

1
1

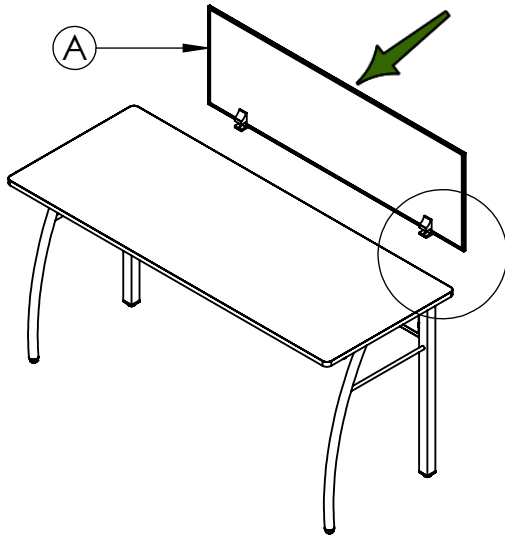

SLIDE SUPPORT BRACKET WITH
POLYCARBONATE DIVIDER TO TABLE TOP

DESLIZAR MINI MAMPARA CON SOPORTE
HACIA LA CUBIERTA DEL ESCRITORIO

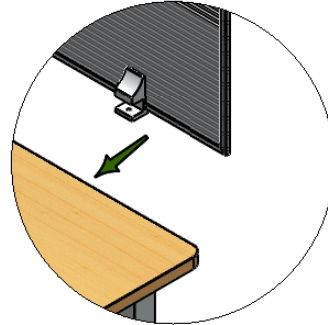

2
2

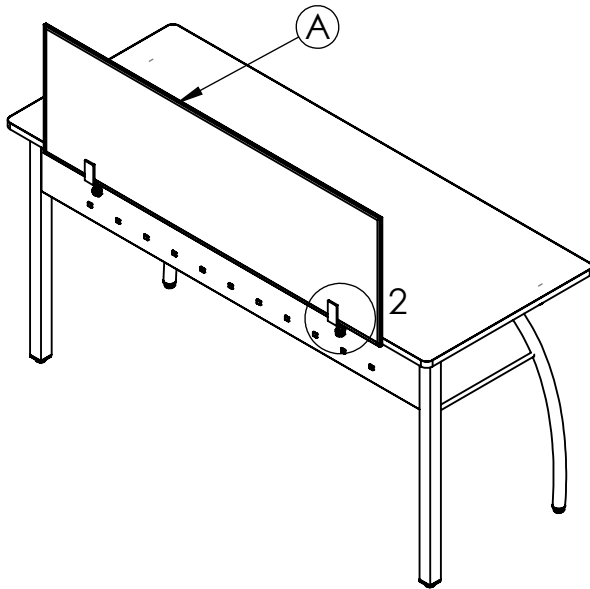

SECURE DIVIDER TO TABLE TOP BY TURNING KNOB TO
TIGHTEN

ASEGURAR MINI MAMPARA APRETANDO LOS
REGATONES DE SEGURIDAD POR LA PARTE INFERIOR DE
LA CUBIERTA

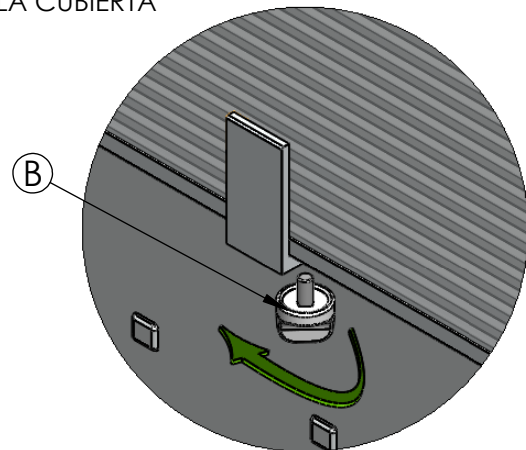

LIMITED 5-YEAR WARRANTY

CREACIONES INDUSTRIALES S.A. DE C.V. (CRISA) WARRANTIES ITS PRODUCTS AGAINST MANUFACTURING, MATERIAL AND WORKMANSHIP DEFECTS TO THE ORIGINAL PURCHASER FROM THE DATE OF PURCHASE FOR A PERIOD OF 5 YEARS. THE WARRANTY IS SUBJECT TO THE PRODUCTS STILL BEING OWNED BY THE ORIGINAL PURCHASER AND INSTALLED, USED AND MAINTAINED IN ACCORDANCE WITH PRODUCT INSTRUCTIONS AND WARNINGS.

WARRANTY DURATION:

- **5 YEARS:** Desks, hutches, panels and file cabinets
- **1 YEAR:** Plastic caps, locks, hinges, fabric, casters, wood seats and accessories. Sienna chair A501

LIMITATIONS:

- Damage caused by the carrier-in-transit is handled under separate terms as defined by the carrier

EXCLUSIONS:

- Damages resulting from improper product installation, assembly or disassembly
- Normal wear and tear as expected over the course of ownership
- Modifications or attachments to the product not approved by CRISA
- Product used for rental purpose

WARRANTY WILL NOT BE APPLICABLE IN THE FOLLOWING CASES:

- 1) Products that were not installed, used or routinely and properly maintained in accordance with product instructions and warnings.
- 7) Product used in different conditions than intended.
- 1) Product not assembled according to the provided written instructions.
- 2) Product changed or repaired by non CRISA authorized personnel
- 3) Defects occurring after the purchase by natural disasters, product modification, intentional damage, accident, misuse, abuse, negligence or exposure to the elements.
- 4) Damages caused by third party carriers other than Creaciones Industriales S.A DE C.V.

TO THE EXTENT ALLOWED BY LAW, CRISA MAKES NO OTHER WARRANTY, EITHER EXPRESS OR IMPLIED, INCLUDING ANY WARRANTY OF MERCHANTABILITY OR FITNESS FOR A PARTICULAR PURPOSE. CRISA WILL NOT BE LIABLE FOR ANY CONSEQUENTIAL OR INCIDENTAL DAMAGES.

Notice to Purchasers for home or personal use:

Federal law does not permit the exclusion of certain implied warranties for consumer products. Therefore, if you are purchasing this product for home or personal use, the exclusion of implied warranties noted in the above paragraph does not apply to you. Some states do not allow the exclusion or limitation of incidental or consequential damages, so the above limitation or exclusion may not apply to you. This warranty gives you specific legal rights, and you may also have other rights which vary from state to state.

WARRANTY PROCEDURE.

- 1) Your Linea Italia reseller will work with CRISA in supporting your warranty request.
- 2) Defects must be reported immediately when discovered. Please contact the Reseller from whom the product was purchased and provide SKU#, invoice # or date of manufacture from the product.
- 3) Provide a detailed description of the problem with photos, lot number and invoice number. It is important not to remove any labels from the product as they provide important traceability information.
- 4) A customer service representative or CRISA will determine whether to provide replacement parts, authorize repairs or replace the product provided CRISA affirms that the product in question is eligible under the conditions of the warranty as stated above.
- 5) CRISA will review the defect and determine whether it is related to material or workmanship. If the defect is not related to manufacturing, cost of replacement parts and shipping will be the customer's responsibility.

CREACIONES INDUSTRIALES S.A DE C.V. RESERVES THE RIGHT TO CHANGE PRODUCTS, TECHNICAL SPECIFICATIONS, ACCESSORY COMBINATIONS, COLORS, IMAGES AND DATA AT ANY TIME WITHOUT NOTICE.