









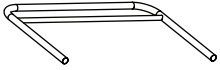
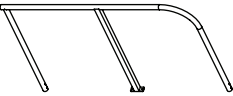
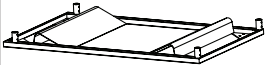

LLR65955

Round Table Cart
Chariot pour tables rondes
Carrito para Mesas Redondas

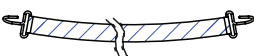

ASSEMBLY INSTRUCTIONS
INSTRUCTIONS DE MONTAGE
INSTRUCCIONES DE ENSAMBLE

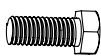
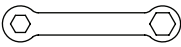
PART LIST

PART	DESCRIPTION		QTY
A	HANDLE		1
B	ENCLOSURE POLE		2
C	BASE		1
D	WHEEL WITH BRAKE		4
E	BOLT		12
F	NUT		12
G	BELT		1
H	NUT		16
I	STEEL WASHER		32
J	BOLT		16
K	SPANNER		2
L	ALLEN WRENCH		1

Step 1: a) Put I on J firstly, assemble D with J & I x 4pcs, another I x 4pcs and H x 4pcs to C.
b) Repeat step a); assemble four wheels to base.

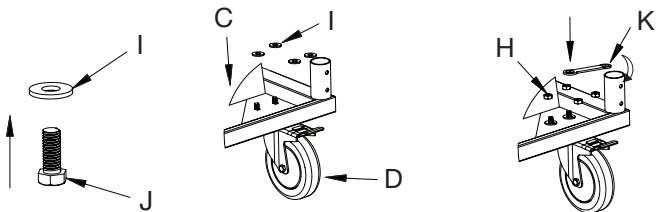



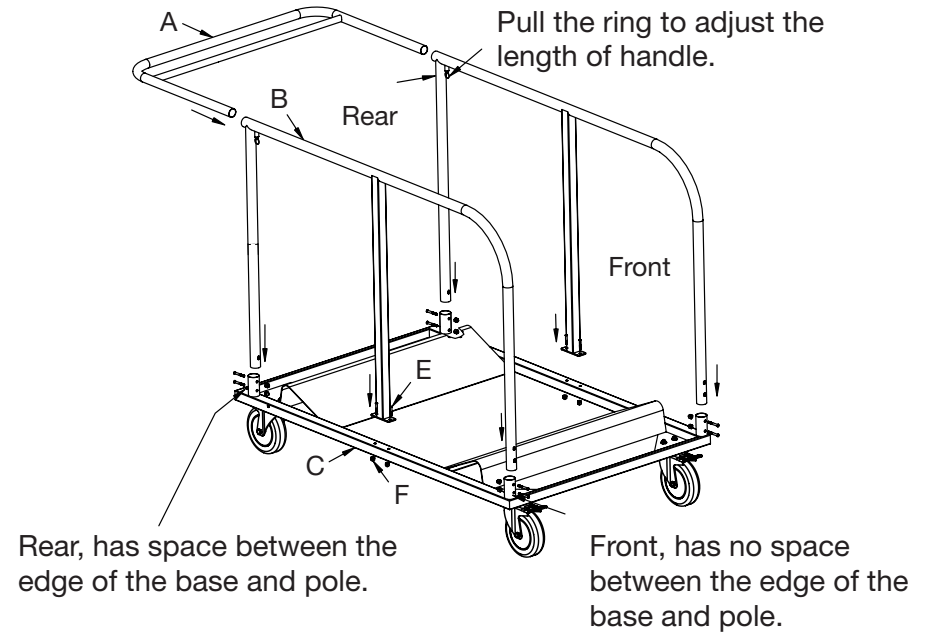



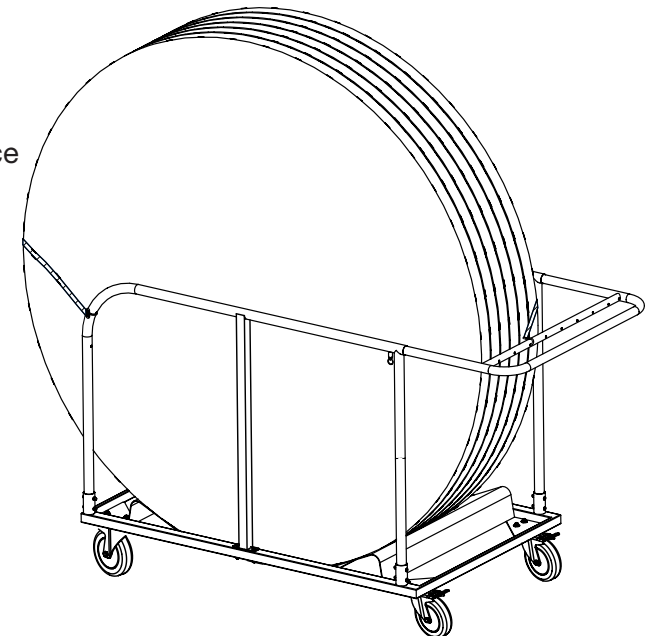

Step 2: Assemble B x 2pcs with E x 12pcs and F x 12pcs to C; pay attention to differentiate between rear and front of C, the rear of B must be fitted to the rear of C.

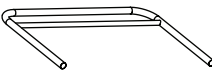
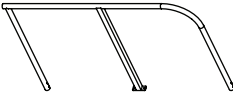
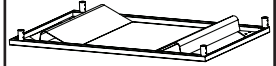

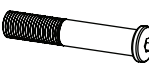
Use attached belt to secure tables if space on trolley is not completely filled.

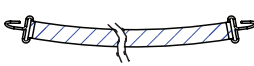

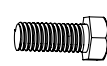
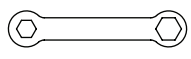
LISTE DES PIÈCES

PIÈCE	DESCRIPTION		QTÉ
A	POIGNÉE		1
B	PROTECTION		2
C	BASE		1
D	ROUE AVEC FREIN		4
E	BOULON		12
F	ÉCROU		12
G	COURROIE		1
H	ÉCROU		16
I	RONDELLE EN ACIER		32
J	BOULON		16
K	CLÉ		2
L	CLÉ ALLEN		1

Étape 1 : a) Mettez I sur J en premier, assemblez D avec J & I x 4 pièces, puis 4 autres pièces de I et 4 pièces de H sur C.
b) Répétez l'étape a); montez les quatre roues sur la base.

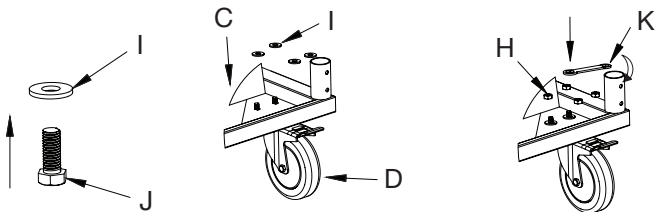

Étape 2 : Montez B x 2 pièces avec E x 12 pièces et F x 12 pièces sur C; faites attention à bien différencier l'avant et l'arrière de C, l'arrière de B doit être raccordé avec l'arrière de C.

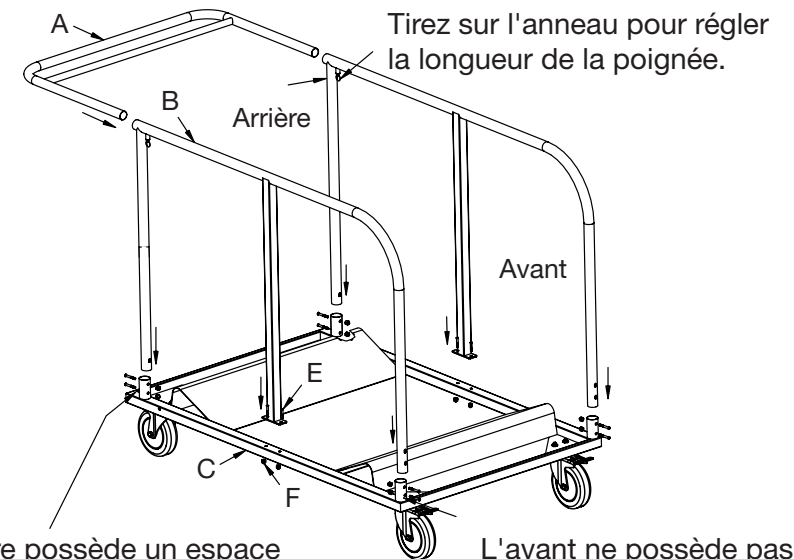

L'arrière possède un espace entre le bord de la base et la protection.

L'avant ne possède pas d'espace entre le bord de la base et la protection.

Utilisez la courroie pour sécuriser les tables si le chariot n'est pas plein.

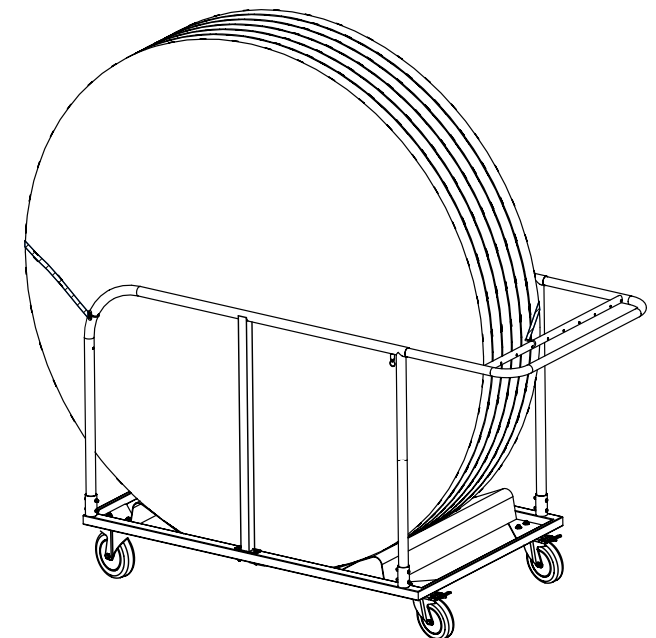

LISTA DE PARTES

PARTE	DESCRIPCIÓN		CANT.
A	MANIJA		1
B	PROTECCIÓN LATERAL		2
C	BASE		1
D	RUEDA CON FRENO		4
E	PERNO		12
F	TUERCA		12
G	CINTA		1
H	TUERCA		16
I	ARANDELA DE ACERO		32
J	PERNO		16
K	LLAVE DE GANCHO		2
L	LLAVE ALLEN		1

Paso 1: a) Primero coloque I en J y ensamble D con J e I (4 piezas). También coloque I (4 piezas) y H (4 piezas) en C.
b) Repita el paso a). Ensamble las cuatro ruedas en la base.

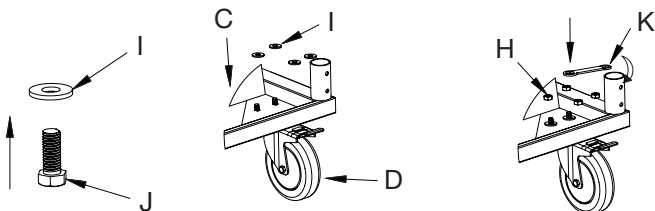

Paso 2: Ensamble B (2 piezas) con E (12 piezas) y F (12 piezas) en C. Asegúrese de diferenciar entre la parte delantera y la parte posterior de C. La parte posterior de B debe ajustarse a la parte posterior de C.

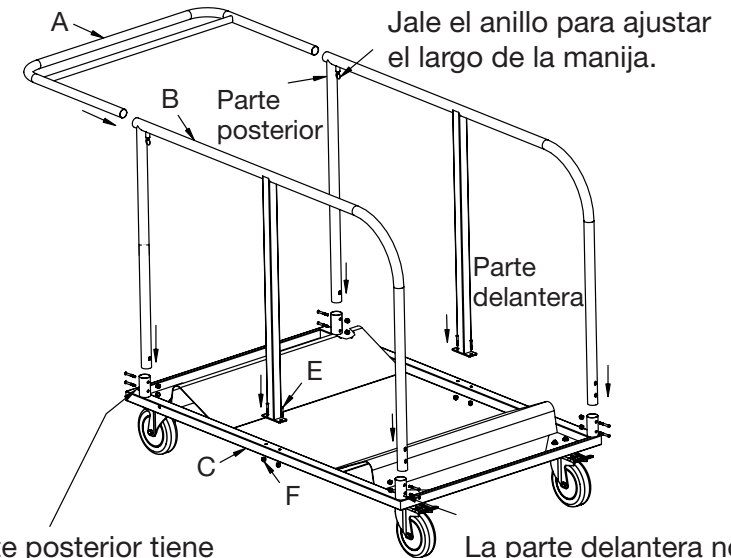

La parte posterior tiene espacio entre la orilla de la base y el poste.

La parte delantera no tiene espacio entre la orilla de la base y el poste.

Utilice la cinta incluida para asegurar las mesas en caso de que quede espacio entre ellas en el carrito.

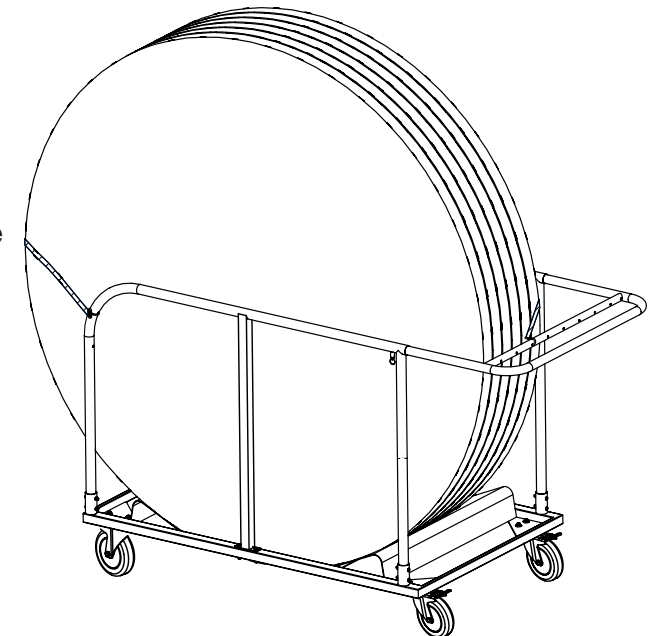

Instructions

If you are missing parts or have other concerns, please email Lorell@sprich.com or fax: 404-472-9063.

Please provide the following information:

1. Full Name
2. Physical Address – do not include P.O. Box as our carriers cannot deliver to a P.O. Boxes
3. Phone Number
4. Model Number
5. Part Number
6. Invoice #
7. Date of Purchase

Note: Our policy is to send all parts requests normal ground transportation, if your requirements are to have these parts via overnight/next day, please provide your designated carrier and account number. Replacement panels are not available. If damaged has occurred during shipment, please return the entire unit to place of purchase for credit and replacement. Original Invoice may be required.

Before you begin:

Open, identify and count all parts prior to assembly. Lay out the parts on a non-abrasive surface such as carpet or blanket.

Instructions

Veillez nous faire parvenir un courriel à lorell@sprich.com ou un fax à : 404-472-9063, s'il vous manque des pièces ou que vous éprouvez d'autres inquiétudes.

Veillez fournir l'information suivante :

1. Nom complet
2. Adresse physique – ne donnez pas votre boîte postale car nos livreurs ne peuvent pas livrer à une boîte postale
3. Numéro de téléphone
4. Numéro de modèle
5. Numéro de pièce
6. # de facture
7. Date de l'achat

Note: Notre politique est de livrer toutes les demandes de pièces par la voie terrestre; prière de fournir le nom de votre transporteur ainsi que votre numéro de compte si vos exigences sont d'avoir ces pièces livrées pendant la nuit/le lendemain. Des panneaux de remplacement ne sont pas disponibles. Si des dommages sont survenus durant le transport, prière de retourner l'unité entière à l'endroit de l'achat pour un crédit et un remplacement. La facture originale peut être exigée.

Avant de commencer:

Ouvrez, identifiez et comptez toutes les pièces avant de procéder à l'assemblage. Disposez les pièces sur une surface non-abrasive telle un tapis ou une couverture.

Instrucciones

Si le faltan partes o tiene alguna pregunta, escriba un mensaje de correo electrónico a Lorell@sprich.com o envíe un fax al 404-472-9063.

Recuerde incluir la siguiente información:

1. Nombre completo
2. Domicilio. No incluye apartado postal debido a que nuestros distribuidores no pueden hacer entregas a un apartado postal.
3. Número telefónico
4. Número de modelo
5. Número de parte
6. No. de factura
7. Fecha de compra

Nota: Nuestra política establece enviar todas las partes solicitadas vía terrestre. Si sus requisitos incluyen tener estas partes con un envío nocturno o al día siguiente, sírvase proporcionar su transportista asignado y número de cuenta.

No se cuenta con tableros de repuesto. Si la unidad sufrió algún daño durante el envío, regrésela completa a donde la adquirió para que le reembolsen su pago y se la reemplacen. Se le podría solicitar su factura original.

Antes de iniciar:

Abra, identifique y cuente todas las partes antes del ensamble. Coloque todas las partes en una superficie no abrasiva, como una alfombra o sábana.