

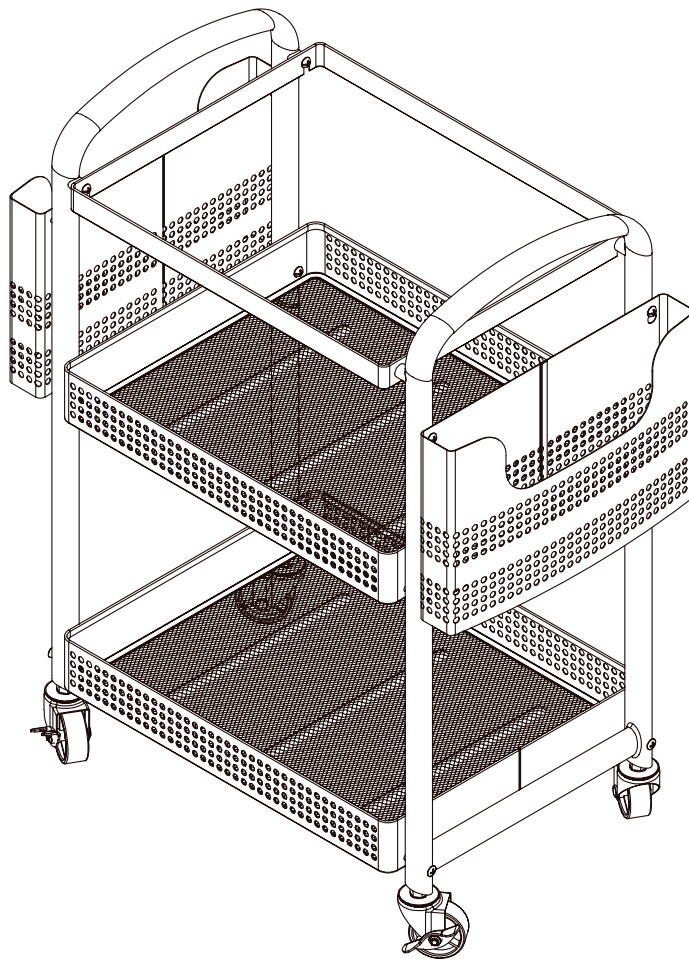

ASSEMBLY INSTRUCTIONS

File Cart

Model: LLR45654



READ AND SAVE THESE INSTRUCTIONS

Manufactured in China for S.P Richards Co., Atlanta, GA

PARTS LIST

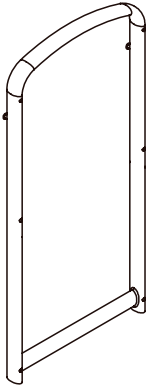

A Side Frame 2X

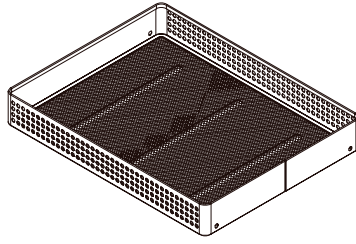

B Paper Tray 2X

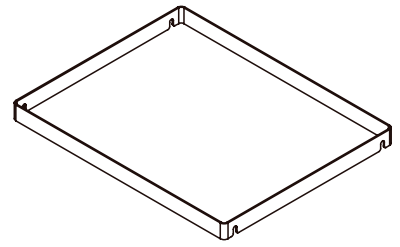

C Top Rail 1X

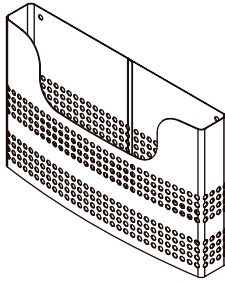

D File Pocket 2X

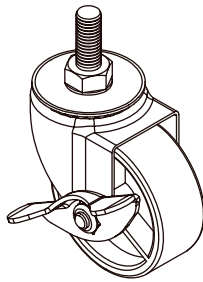

E Caster with Brake 2X

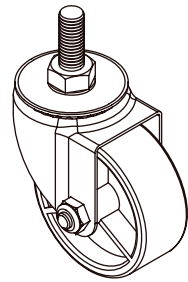

F Caster 2X

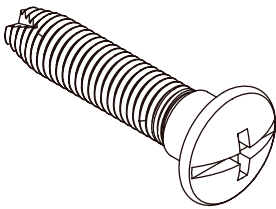

1 Stepped Bolt 8X

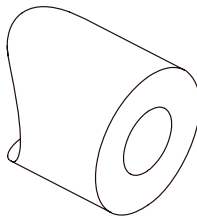

2 Plastic Part 4X

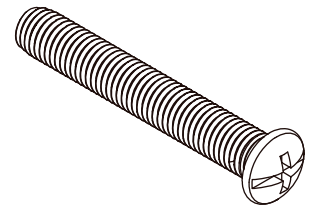

3 Bolt 8X

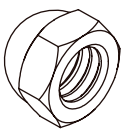

4 Screw Cap 8X

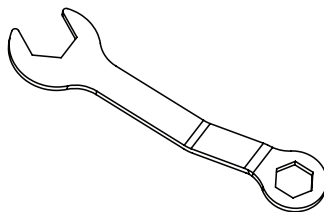

5 Wrench 1X

Tool needed

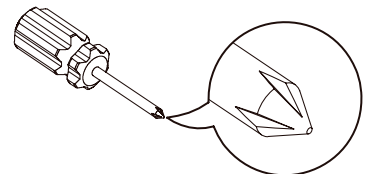

Phillips head screwdriver is needed but not included.

STEP 1

Install the plastic parts **2** and stepped bolt **1** to the top hole on the side frame **A**.
Attach casters **E** & **F** to the side frame **A**.

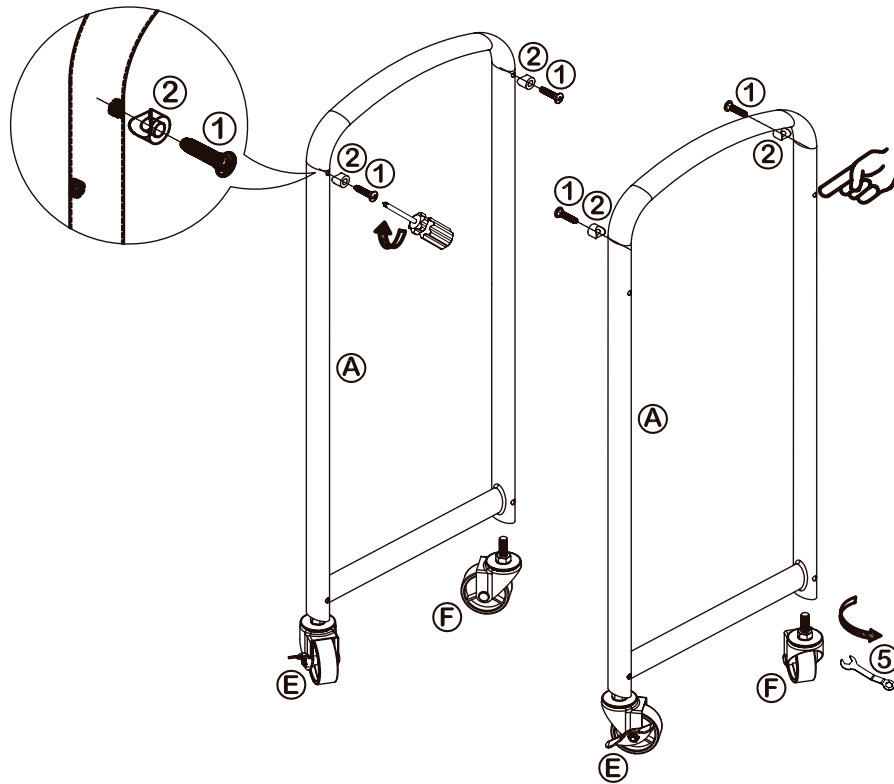

STEP 2

Attach paper tray **B** to side frame **A**.

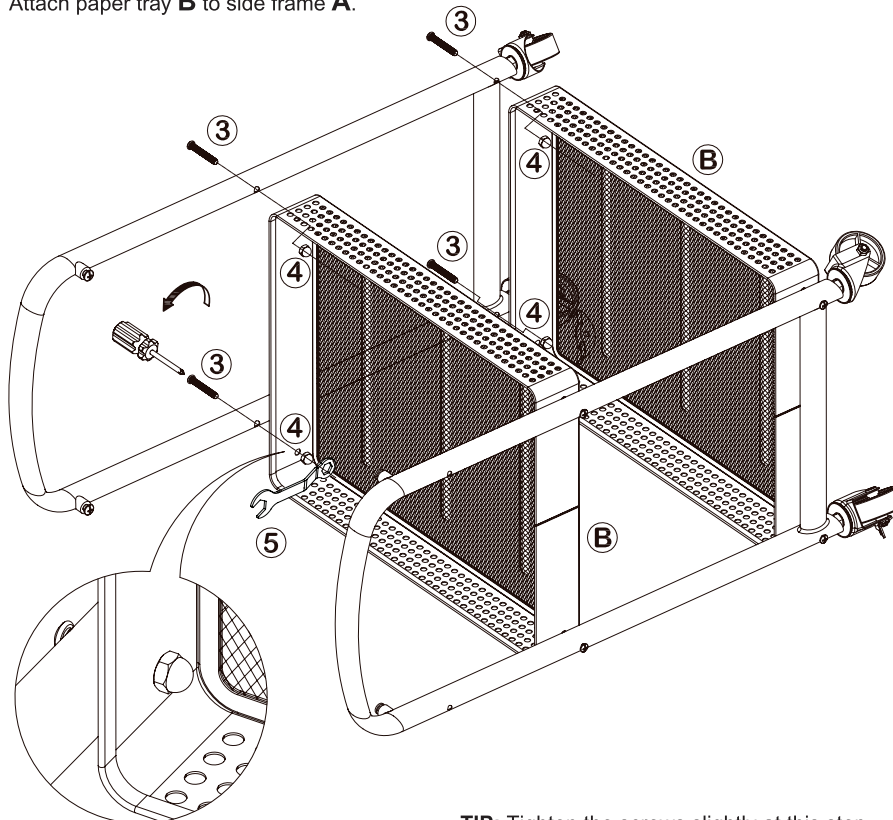

TIP: Tighten the screws slightly at this step.

STEP 3

Install stepped bolt 1 to side frame **A**.

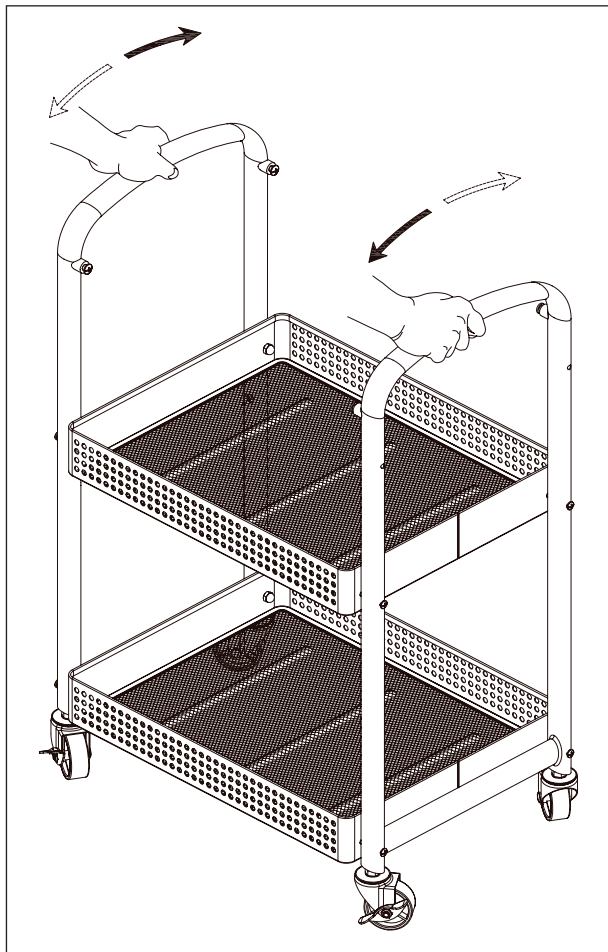
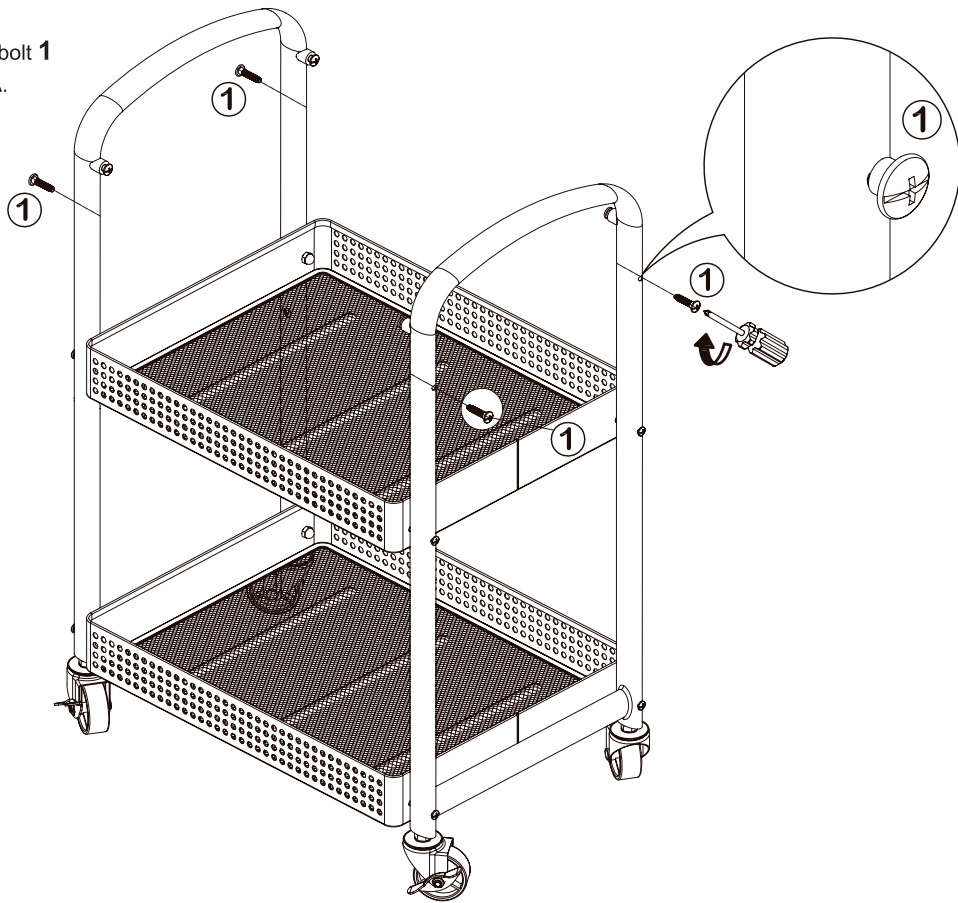

TIP: If there is wobble on the casters, adjust the side frame as per illustration.

STEP 4

Hang the top rail **C** and file pocket **D** to the side frame **A**.

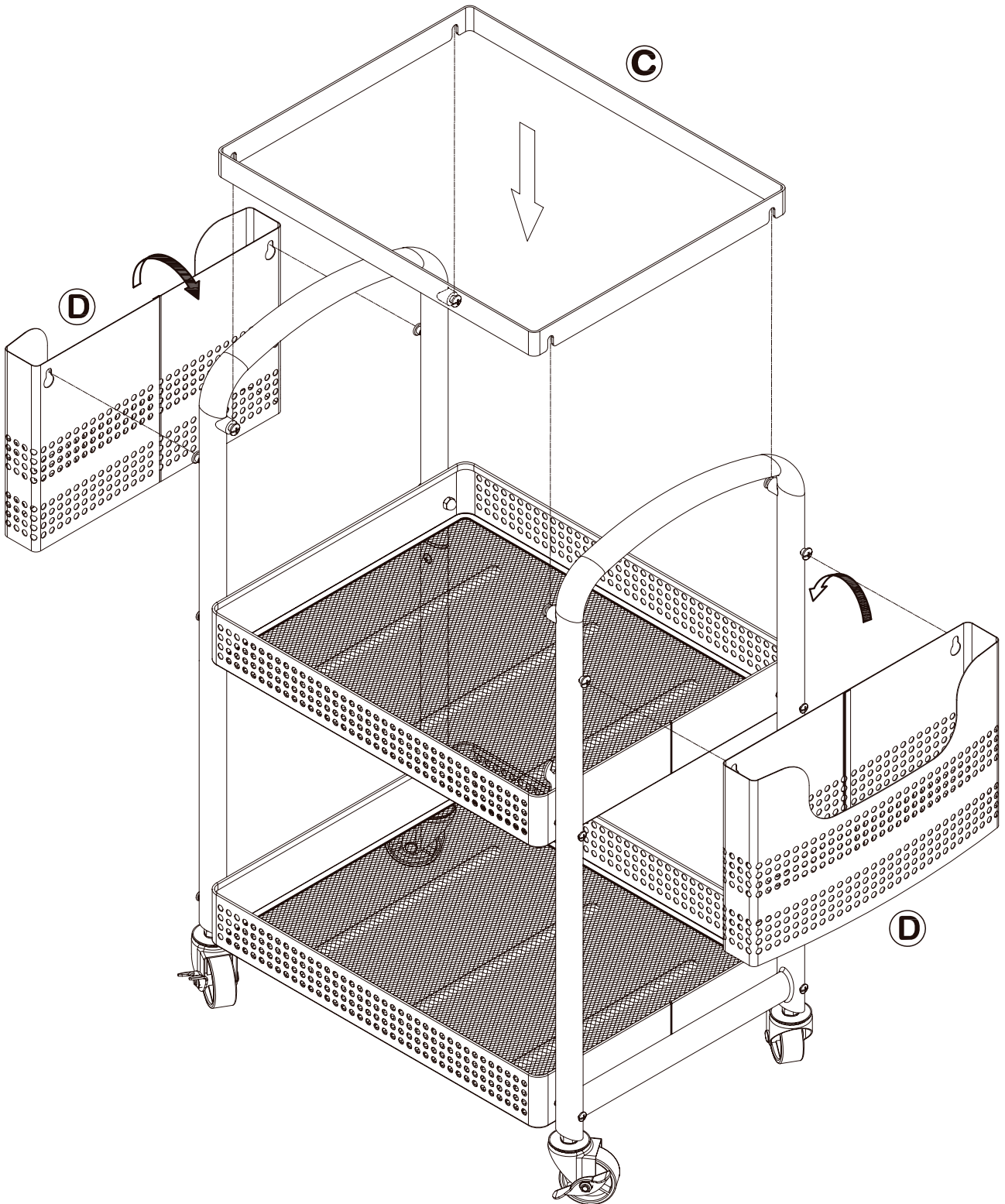

STEP 5

Product is fully assembled.

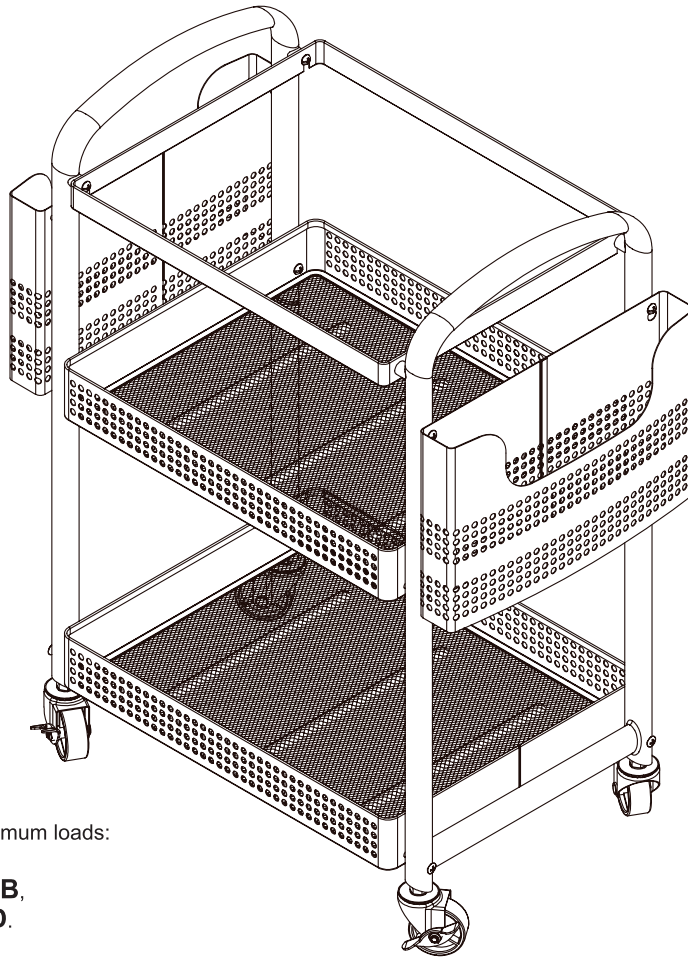

- ⚠ Recommended maximum loads:
15 lbs for top rail **C**,
12 lbs for paper tray **B**,
5 lbs for file pocket **D**.

Accommodate both Letter size and Legal size folders.

Letter size

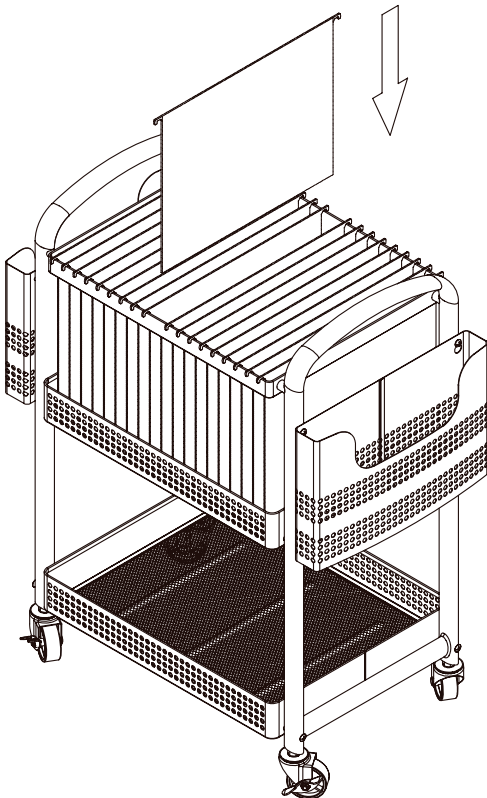

Legal size

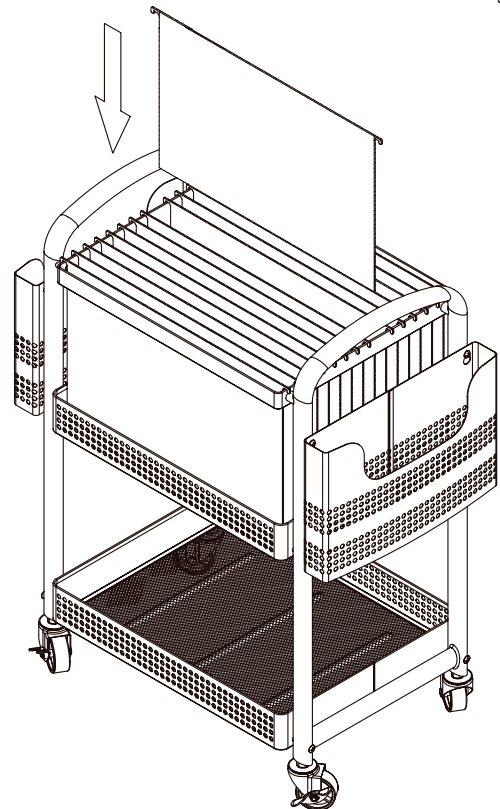



INSTRUCTIONS D'ASSEMBLAGE

Classeur

Modèle : LLR45654

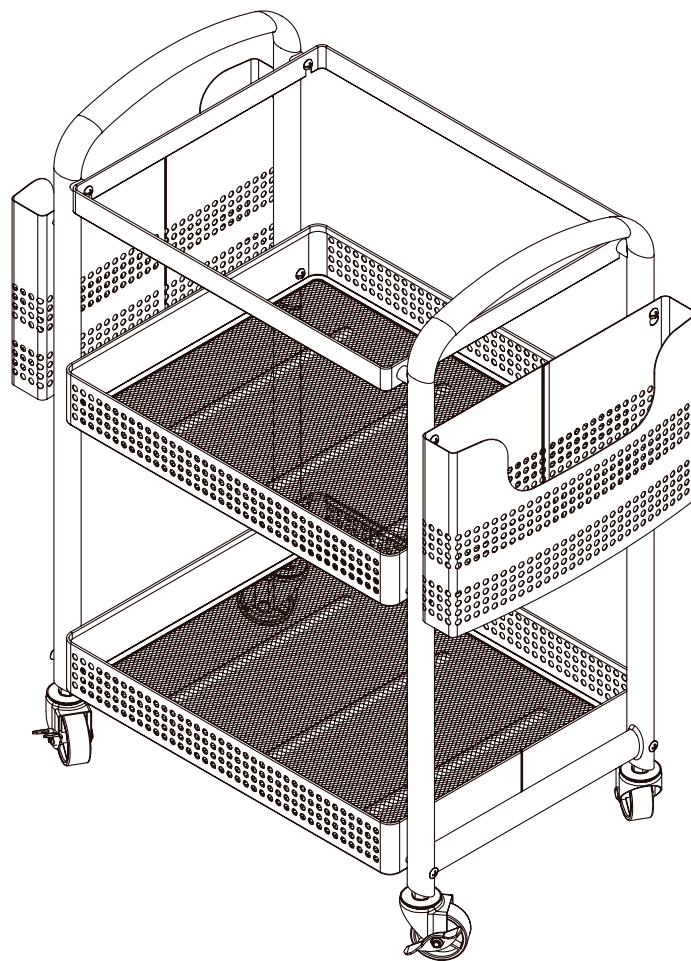

**VEUILLEZ LIRE ET CONSERVER CES
INSTRUCTIONS IMPORTANTES RELATIVES
À LA SÉCURITÉ**

Fabriqué en Chine pour S.P Richards Co., Atlanta, GA (É.-U.)

LISTE DU CONTENU

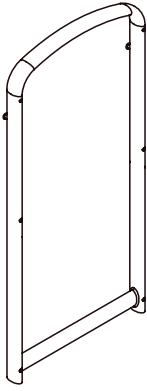

A Châssis latéral 2X

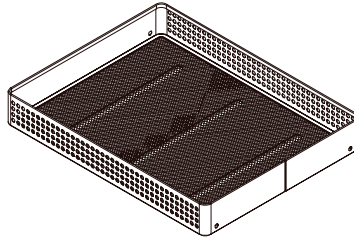

B Bac à papier 2X

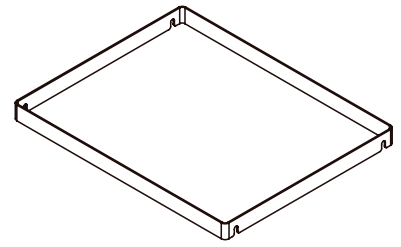

C Rail supérieur 1X

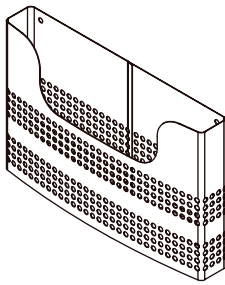

D Range-documents 2X

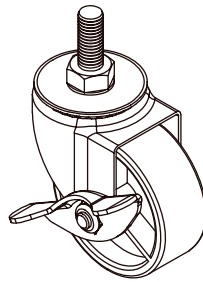

E Roulette avec frein 2X

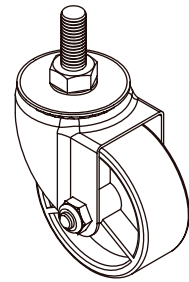

F Roulette 2X

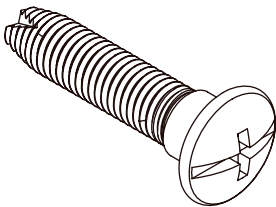

1 Boulon conique 8X

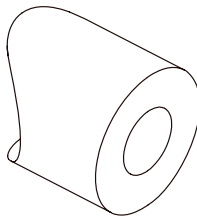

2 Pièce de plastique 4X

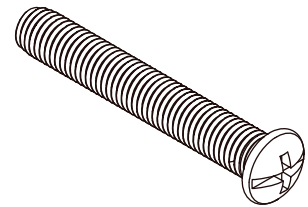

3 Boulon 8X

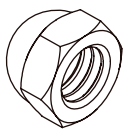

4 Capuchon fileté 8X

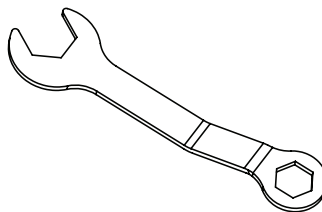

5 Clé de serrage 1X

Tool needed

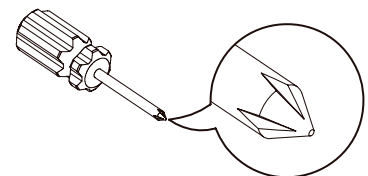

Tournevis cruciforme
(non inclus)

ÉTAPE 1

Insérer la pièce de plastique **2** et un boulon conique **1** dans le trou supérieur du châssis **A**.
Insérer les roulettes **E** et **F** dans le châssis **A**.

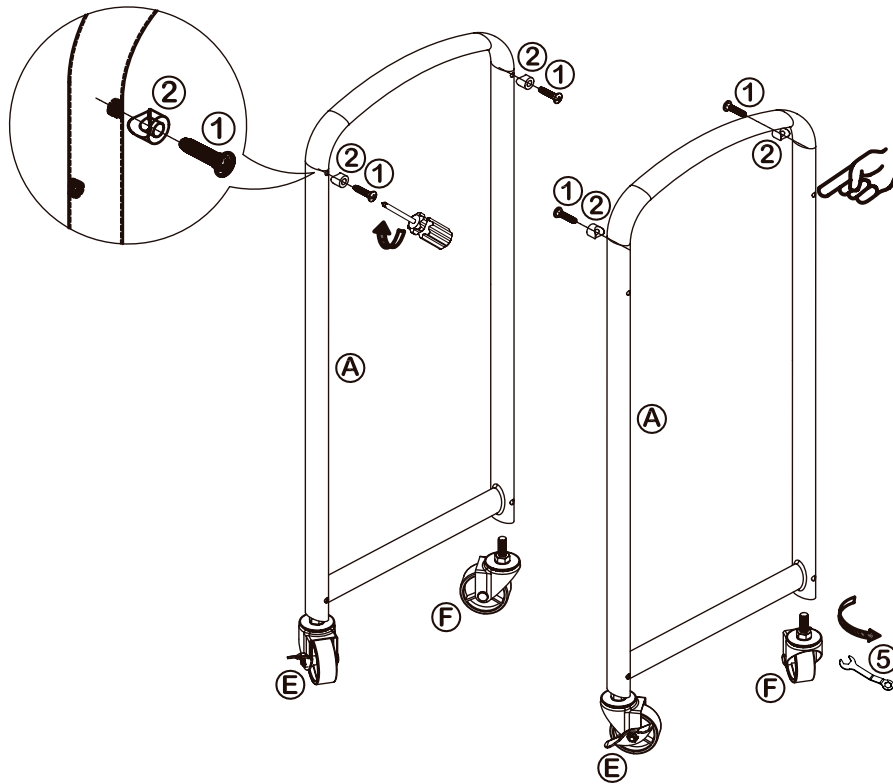

ÉTAPE 2

Accrocher le bac à papier **B** au châssis **A**.

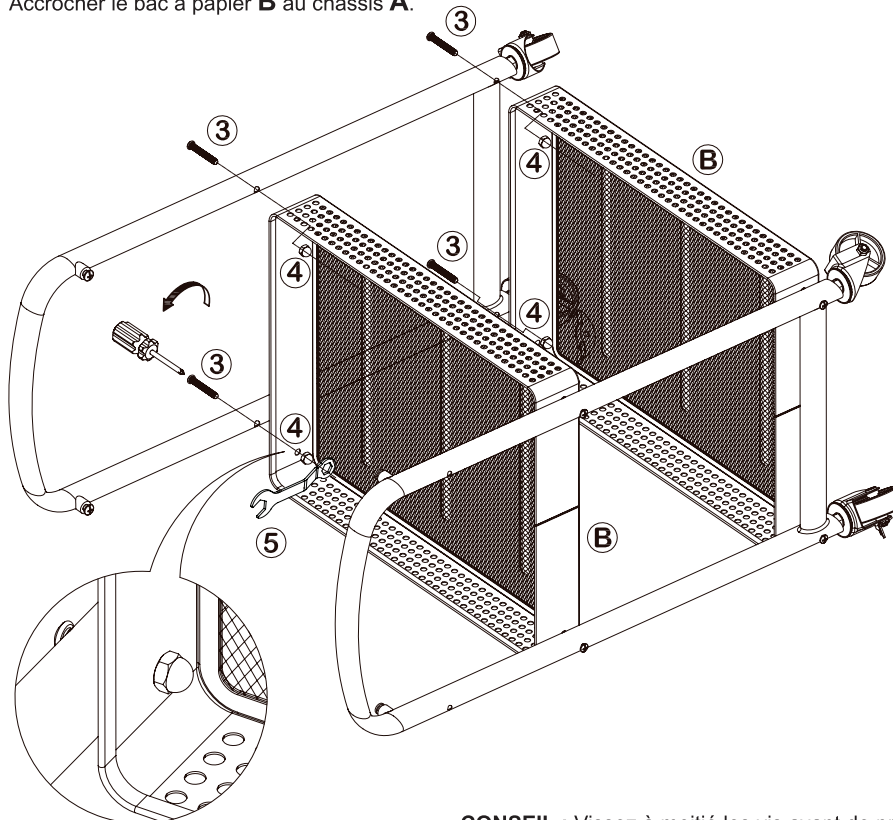

CONSEIL : Vissez à moitié les vis avant de procéder.

ÉTAPE 3

Insérer un boulon conique dans le châssis A.

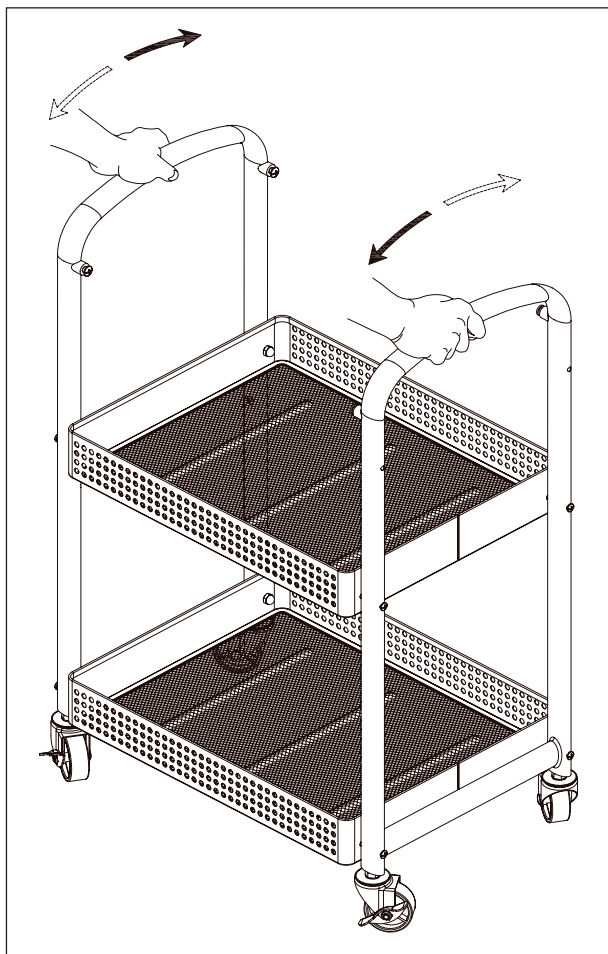
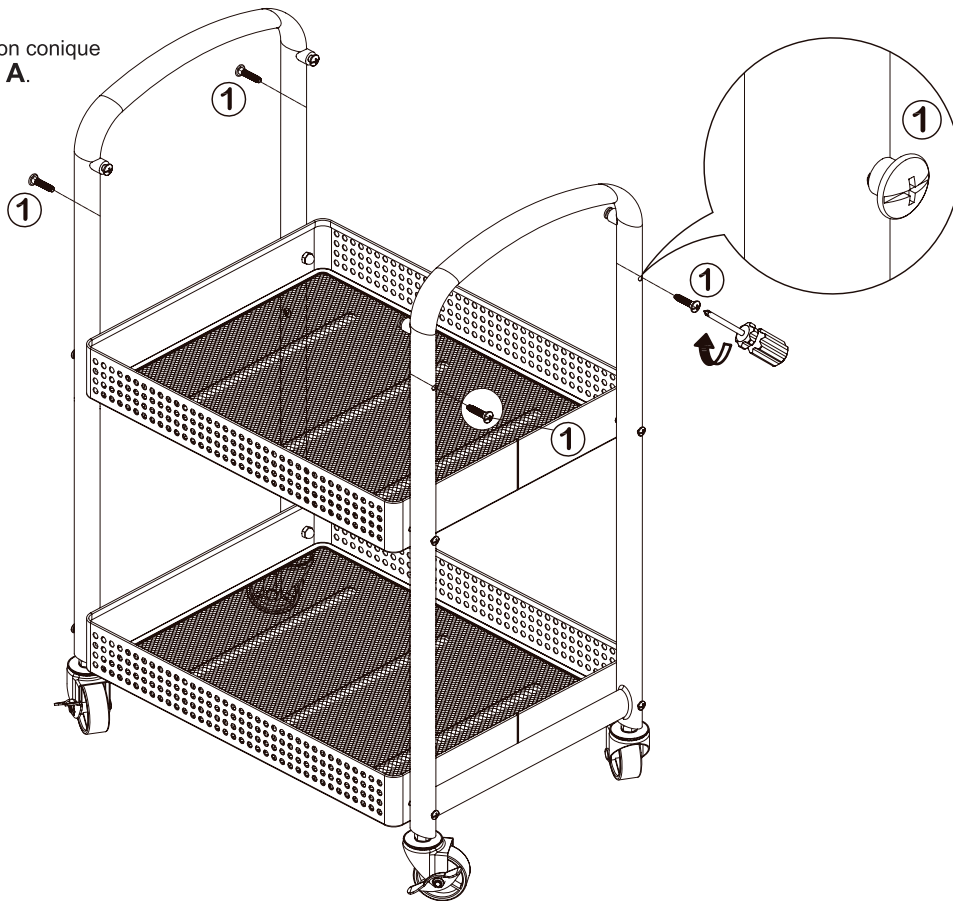

CONSEIL : Si les roulettes sont instables, ajuster le châssis tel qu'illustré.

ÉTAPE 4

Accrocher le rail supérieur **C** et le range-documents **D** au châssis **A**.

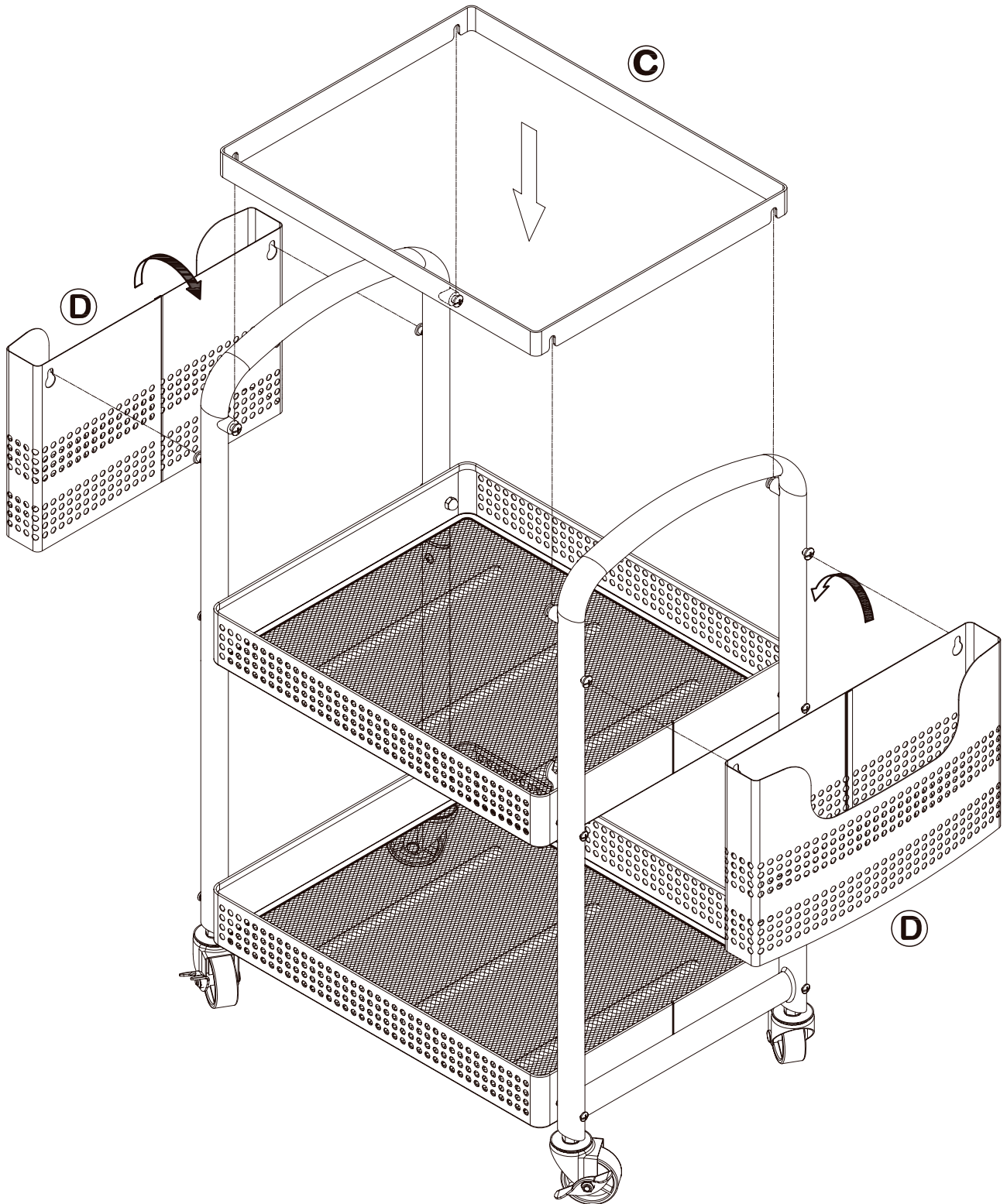

ÉTAPE 5

Vous avez terminé le montage.

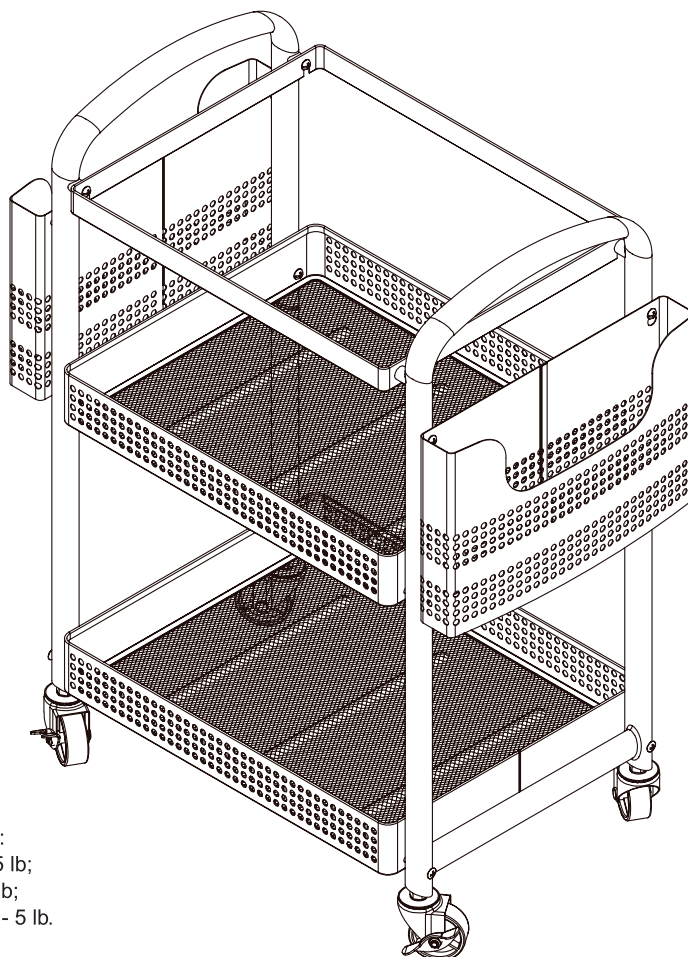

⚠ Charges maximales :
Rail supérieur **C** - 15 lb;
bac à papier **B** - 12 lb;
range-documents **D** - 5 lb.

Compatible avec les chemises de format normal ou de grand format.

Format normal

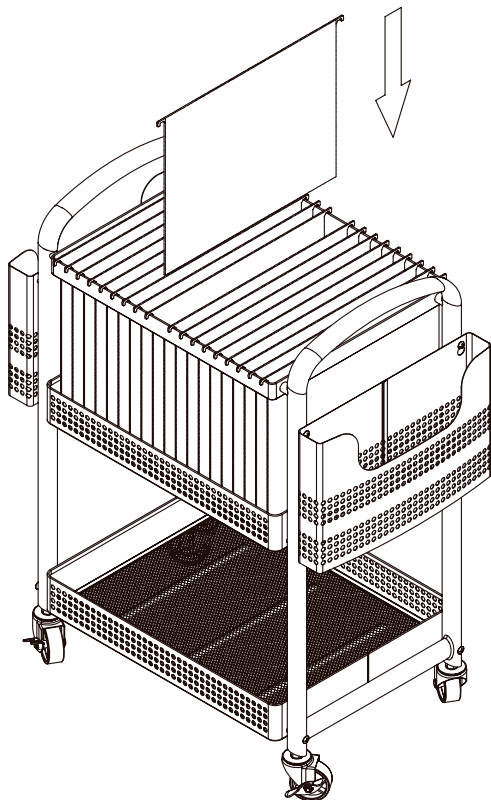

Grand format

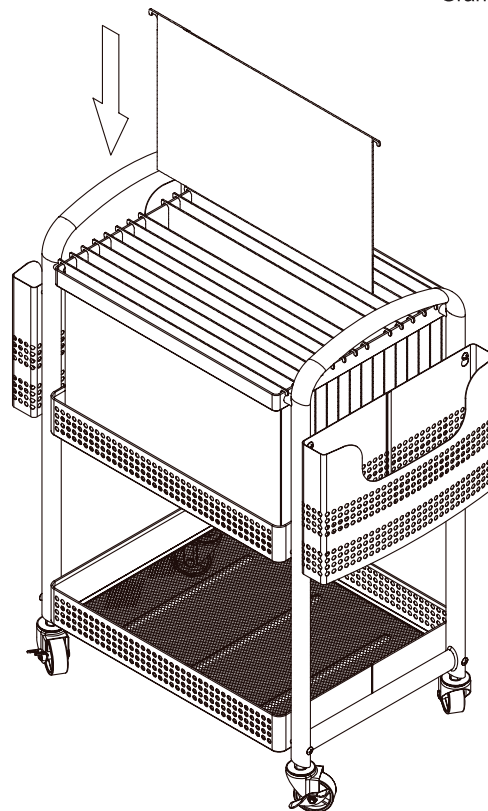



INSTRUCCIONES DE ENSAMBLE

Carretilla archivadora

Modelo: LLR45654

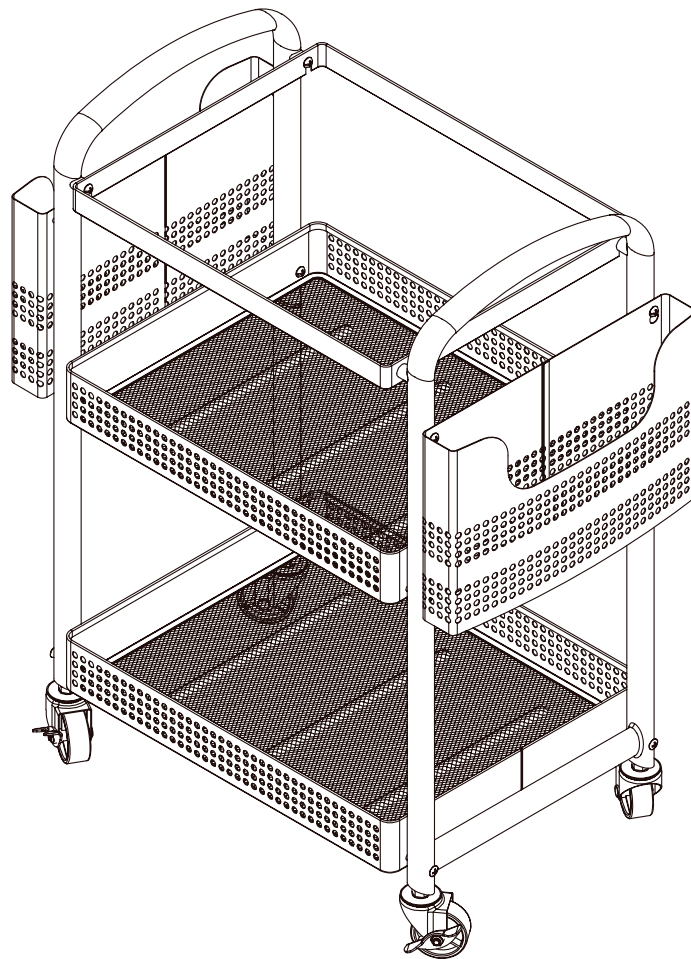

**LEA Y GUARDE ESTAS IMPORTANTES
INSTRUCCIONES DE SEGURIDAD**

Hecho en China para S.P. Richards Co., Atlanta, GA (EE.UU.)

LISTA DE PIEZAS

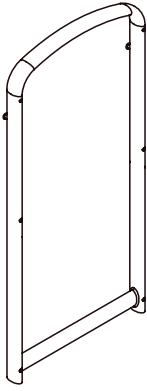

A Armazón lateral 2X

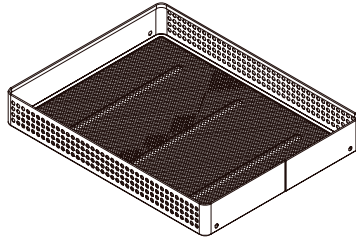

B Bandeja para papeles 2X

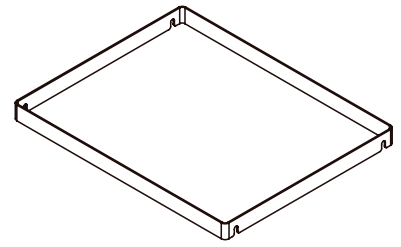

C Riel superior 1X

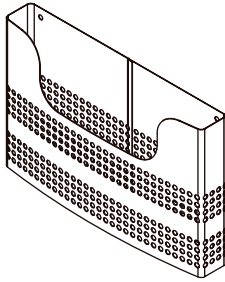

D Bolsillo archivador 2X

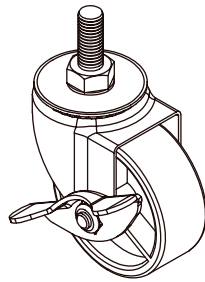

E Rueda con freno 2X

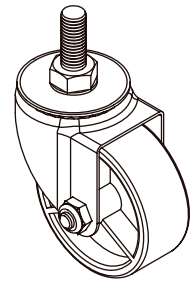

F Rueda 2X

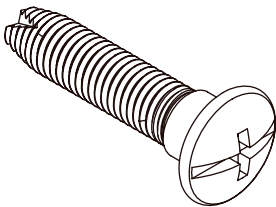

1 Perno de cabeza redonda 8X

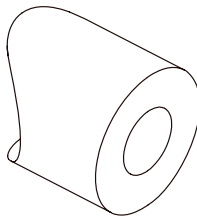

2 Pieza de plástico 4X

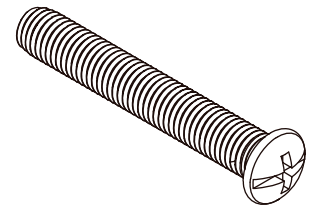

3 Perno 8X



4 Tapón de tornillo 8X

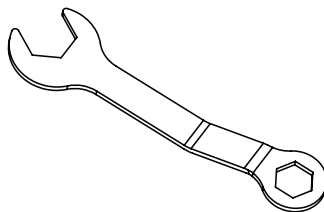

5 Llave inglesa 1X

Tool needed

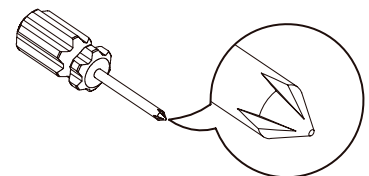

Tornillo de cabeza Phillips (no incluido)

PASO 1

Instale las piezas de plástico **2** y el perno de cabeza redonda **1** en el orificio superior de la armazón lateral **A**.
Fije las ruedas **E** y **F** en la armazón lateral **A**.

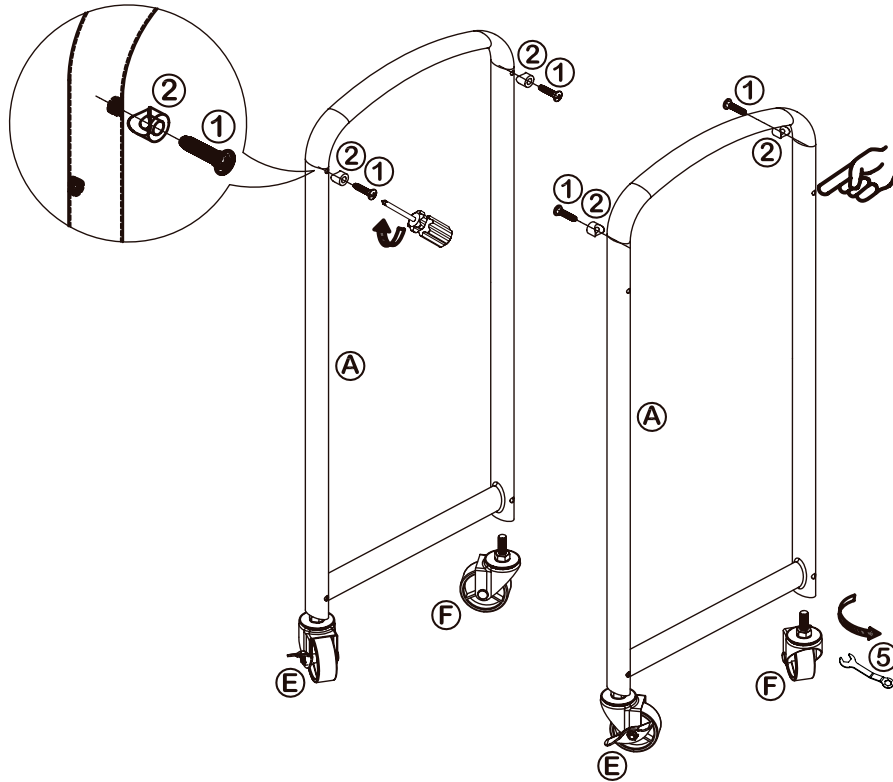

PASO 2

Fije la bandeja para papeles **B**
en la armazón lateral **A**.

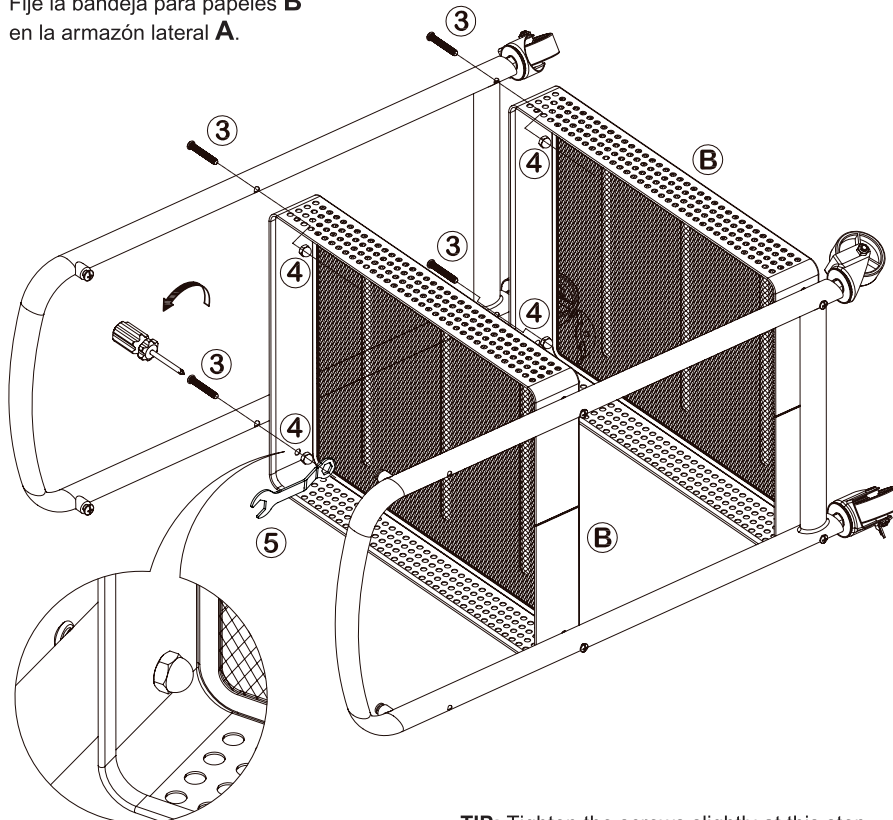

TIP: Tighten the screws slightly at this step.

PASO 3

Instale el perno de cabeza redonda **1** en la armazón lateral **A**.

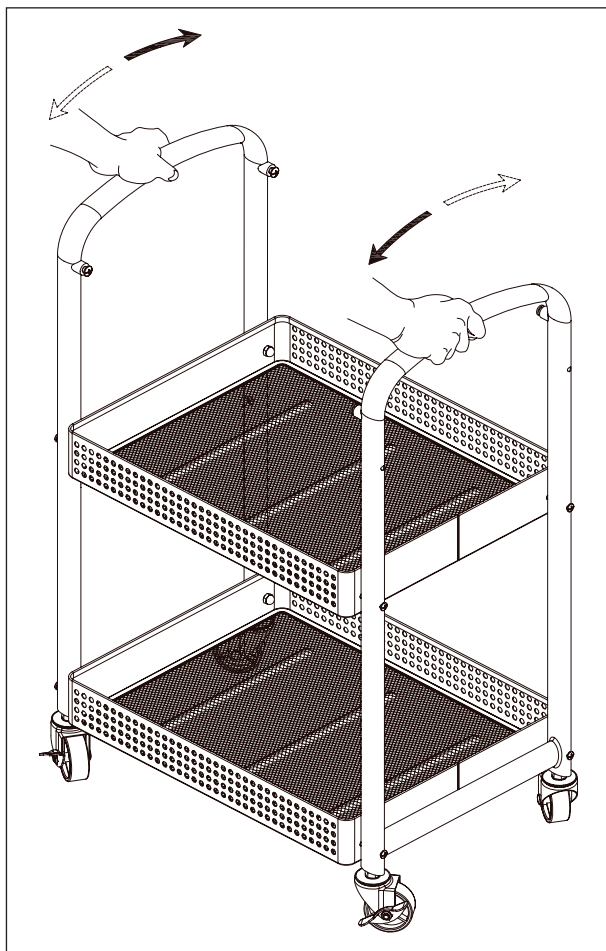
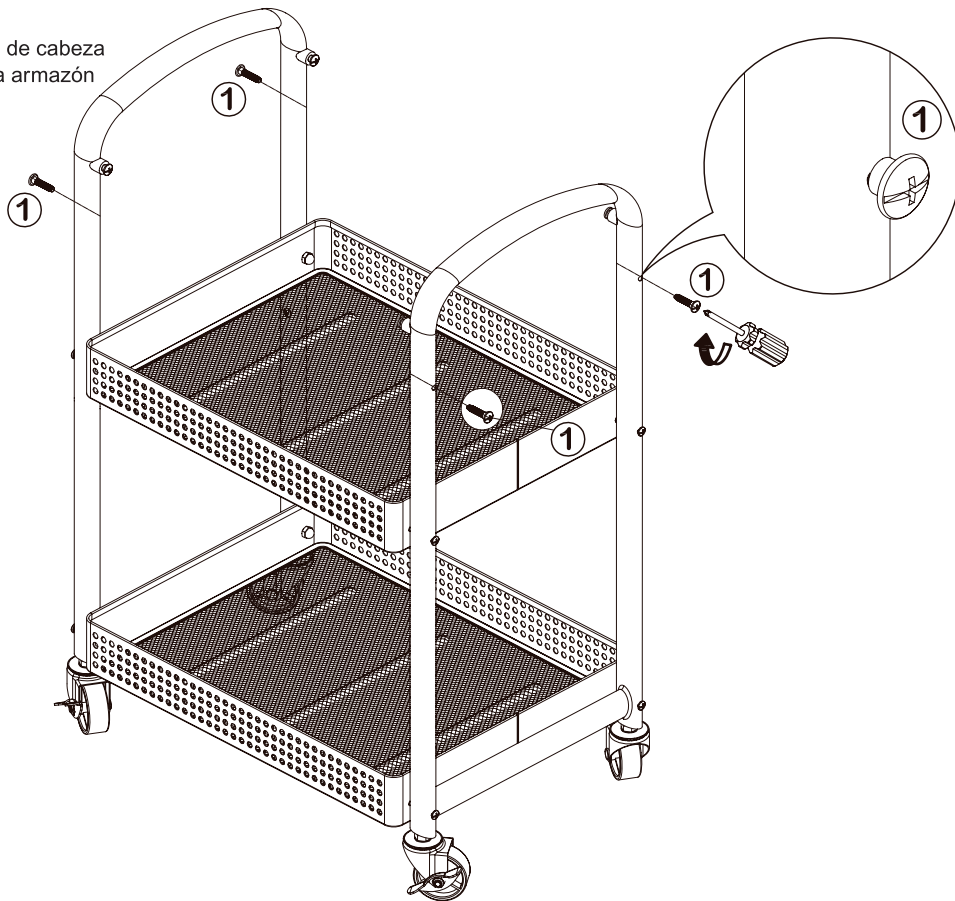

CONSEJOS: Si las ruedas se tambalean, ajuste la armazón lateral como lo muestra la ilustración abajo.

PASO 4

Cuelgue el riel superior **C** y el bolsillo archivador **D** de la armazón lateral **A**.

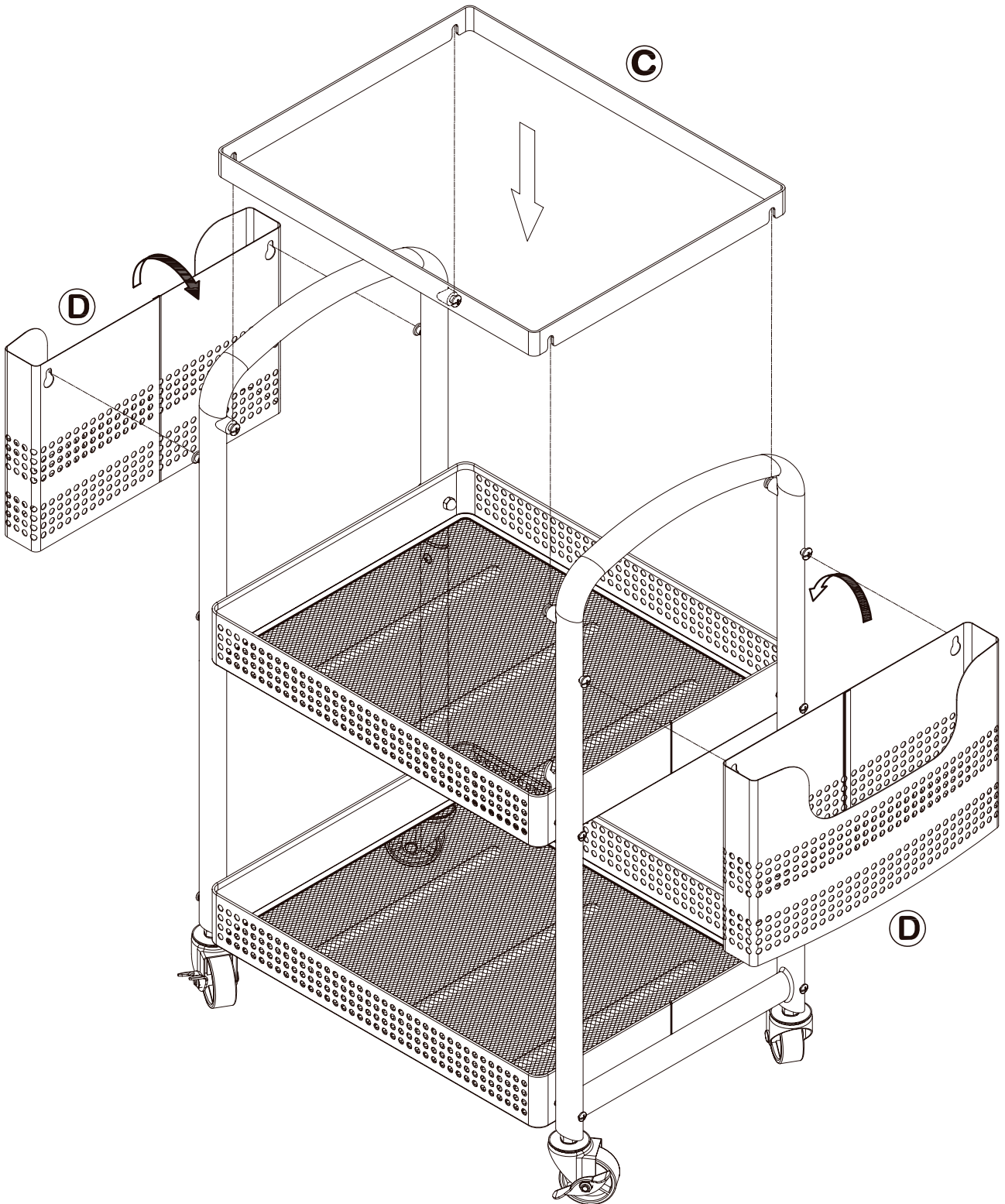

PASO 5

El producto está totalmente armado.

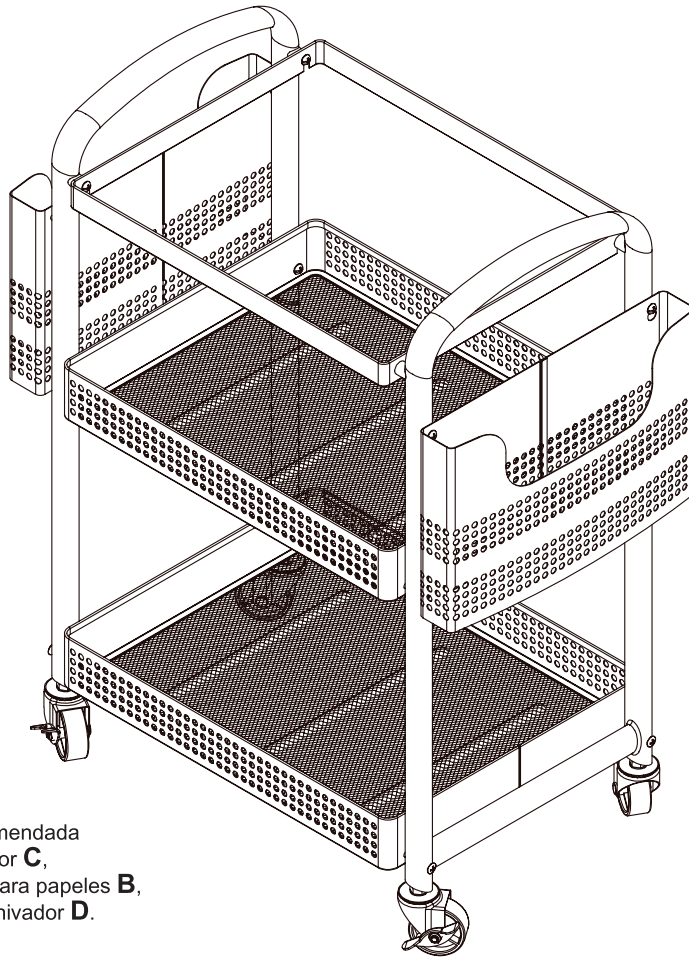

⚠ Carga máxima recomendada
15 lb para riel superior **C**,
12 lb para bandeja para papeles **B**,
5 lb para bolsillo archivador **D**.

Tiene capacidad para carpetas tamaño carta y tamaño legal

Tamaño carta

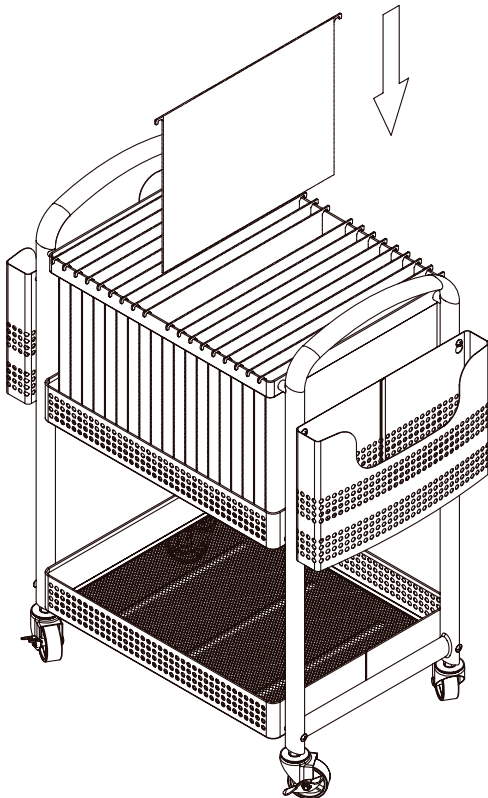

Tamaño legal

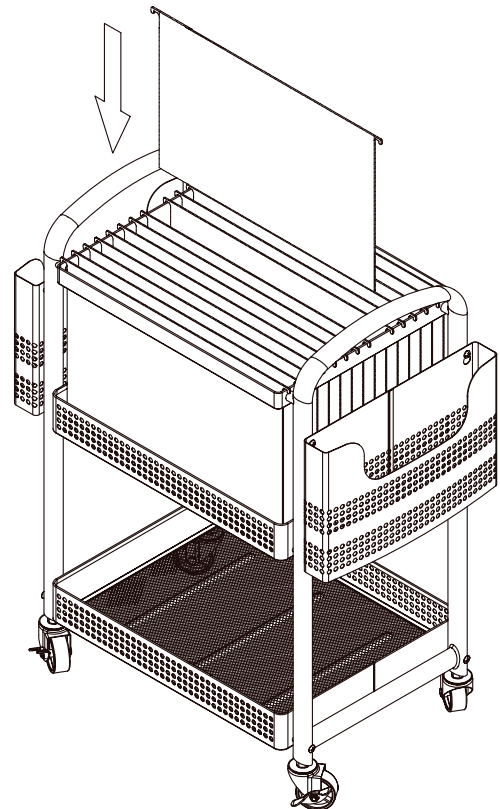



Instructions

CALL US FIRST! DO NOT RETURN TO STORE.

For immediate help with assembly or product information call our toll-free number: **1-888-598-7316** Mon. - Fri. 7am to 7 pm CST
Our staff is ready to provide assistance. Damaged or missing parts ship from our facility in 1-2 business days.

Please provide the following information:

1. Full Name
2. Physical Address – do not include P.O. Box as our carriers cannot deliver to P.O. Boxes
3. Phone Number
4. Model Number
5. Part Number
6. Invoice #
7. Date of Purchase

Note: Our policy is to send all parts requests via normal ground transportation. If your requirements are to have these parts via overnight/next day, please provide your designated carrier and account number. Replacement panels are not available. If any damage has occurred during shipment please return the entire unit to place of purchase for credit and replacement. Original invoice may be required.

Before you begin:

Open, identify and count all parts prior to assembly. Lay out the parts on a non-abrasive surface such as carpet or blanket.

Instructions

APPELEZ-NOUS D'ABORD! NE REVENEZ PAS AU MAGASIN.

Pour obtenir une aide immédiate concernant l'assemblage ou des informations sur les produits, appelez notre numéro sans frais :
1-888-598-7316 Lun. - vend. 7h à 19 h CST Notre personnel vous attend pour vous offrir son aide.
Les pièces endommagées ou manquantes sont expédiées de nos locaux sous 1 à 2 jours ouvrables.

Veuillez inclure les informations suivantes :

1. Nom complet
2. Adresse physique – ne pas inclure de boîte postale, car nos porteurs ne peuvent pas livrer à ces boîtes.
3. Numéro de téléphone
4. Numéro de modèle
5. Numéro de pièce
6. Numéro de facture
7. Date d'achat

Remarque : Notre politique est d'envoyer toutes les pièces demandées par transport terrestre normal. Si vous voulez recevoir ces pièces le jour suivant, indiquez votre porteur désigné ainsi qu'un numéro de compte. Nous ne fournissons pas de panneaux de rechange. En cas d'endommagement en cours de transport, renvoyez l'unité entière au lieu d'achat pour recevoir un crédit ou un échange. La facture originale vous sera peut-être demandée.

Avant de commencer:

Ouvrez, identifiez et comptez toutes les pièces avant l'assemblage. Disposez à plat les pièces sur une surface non abrasive comme un tapis ou une couverture.

Instrucciones

¡LLÁMENOS PRIMERO! NO DEVUELVA EL PRODUCTO A LA TIENDA.

Para recibir ayuda inmediata con el ensamble o información del producto, llame a nuestro número gratuito: **1-888-598-7316**
De lunes a viernes de 7 a.m. a 7 p.m., hora del Centro. Nuestro personal está preparado para brindarle asistencia.
Las partes dañadas o faltantes saldrán de nuestras instalaciones en el transcurso de 1 a 2 días hábiles.

Recuerde proporcionar la siguiente información:

1. Nombre completo
2. Domicilio físico – No incluya apartados postales debido a que no podemos realizar entregas en un apartado postal.
3. Número telefónico
4. Número de modelo
5. Número de parte
6. Número de factura
7. Fecha de compra

Nota: Nuestra política es enviar todas las solicitudes de partes por transporte terrestre regular. Si usted solicitó el envío de estas partes durante la noche o con entrega al día siguiente, proporcione el nombre de su compañía de mensajería y su número de cuenta. Los paneles de repuesto no están disponibles. Si ocurrió algún daño durante el envío, devuelva la unidad completa al lugar de compra para su devolución o reposición. Es posible que le pidan la factura original.

Antes de iniciar:

Abra, identifique y cuente todas las partes antes del ensamble. Coloque todas las partes en una superficie no abrasiva, como una alfombra o sábana.