

SPECIFICATIONS

NIPOMO

NativeStone® Collection



TOP VIEW

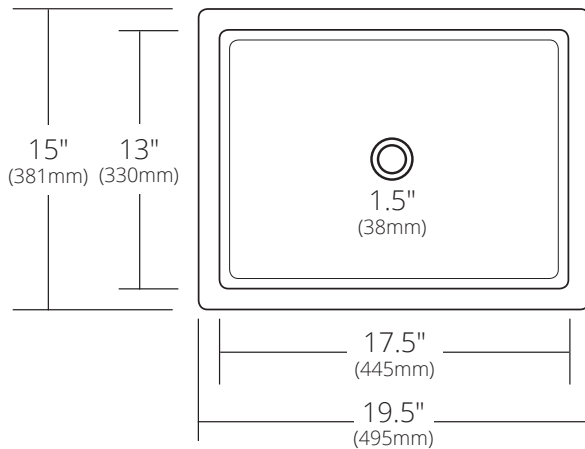

FRONT VIEW

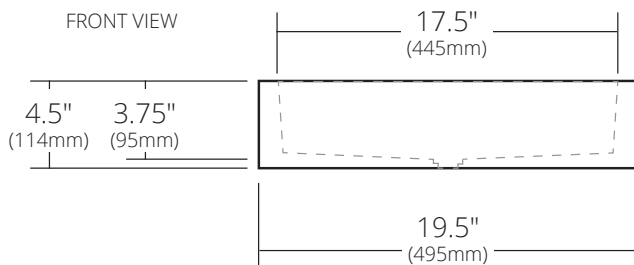

NSL1915-A Ash
NSL1915-S Slate
NSL1915-P Pearl
NSL1915-E Earth

PRODUCT DETAILS

- 19.5" x 15" x 4.5" OD (495mm x 381mm x 114mm)
- 17.5" x 13" x 3.75" ID (445mm x 330mm x 95mm)
- 1.5" (38mm) drain opening
- Handcrafted from sustainable NativeStone®
- Sealed with impermeable nano sealer

INSTALLATION

- Apron-front
- Standard Undermount (concealed apron)
- Vessel

COORDINATING PRODUCTS

- Drains: DR120, DR130 or DR150
- NativeStone® Sealer

STANDARDS COMPLIANCE

- UPC/cUPC compliant

IMPORTANT

Do NOT use tape or other adhesives on NativeStone® as it may remove the sealer.

Due to the handcrafted nature of this product, it will vary in finish, texture, and other details. Dimensions may vary up to ¼" (6mm).