



PROFESSIONAL DEEP CYCLE AGM

Key benefits

- Ideal for boats, yachts, motorhomes, buses, trucks, hydraulic ramps and platforms, electrical drives, mobility, solar and industrial applications
- AGM technology for high rate discharge performance, plus superb shock and vibration resistance
- Exceptionally long lasting – up to eight times the cyclic stability of conventional batteries
- Tough and 100% leak proof construction
- Ideal for all your starter and supply requirements



For more information visit www.varta-automotive.com

ORDER INFORMATION

European Type No. (ETN):	830 210 118
Article Number:	830 210 118 D95 2
Short Code:	LAD 210
Barcode:	4016987144633
Packaging Unit:	1
Quantity per Pallet:	12

TECHNICAL INFORMATION

Voltage [V]:	12	Width [mm]:	209
Battery Capacity [Ah]:	210	Height [mm]:	214
Battery Capacity 5h [Ah]:	172	Base Hold-down:	B00
Cold Cranking Amps (CCA), EN [A]:	1180	Layout:	3
Cold Cranking Amps (SAE) @ -18°C:	1298	Terminal Types:	1
Marine Cranking Amps (SAE) @ 0°C:	1510	Weight filled (kg):	60,2
Length [mm]:	530		

DRAWINGS

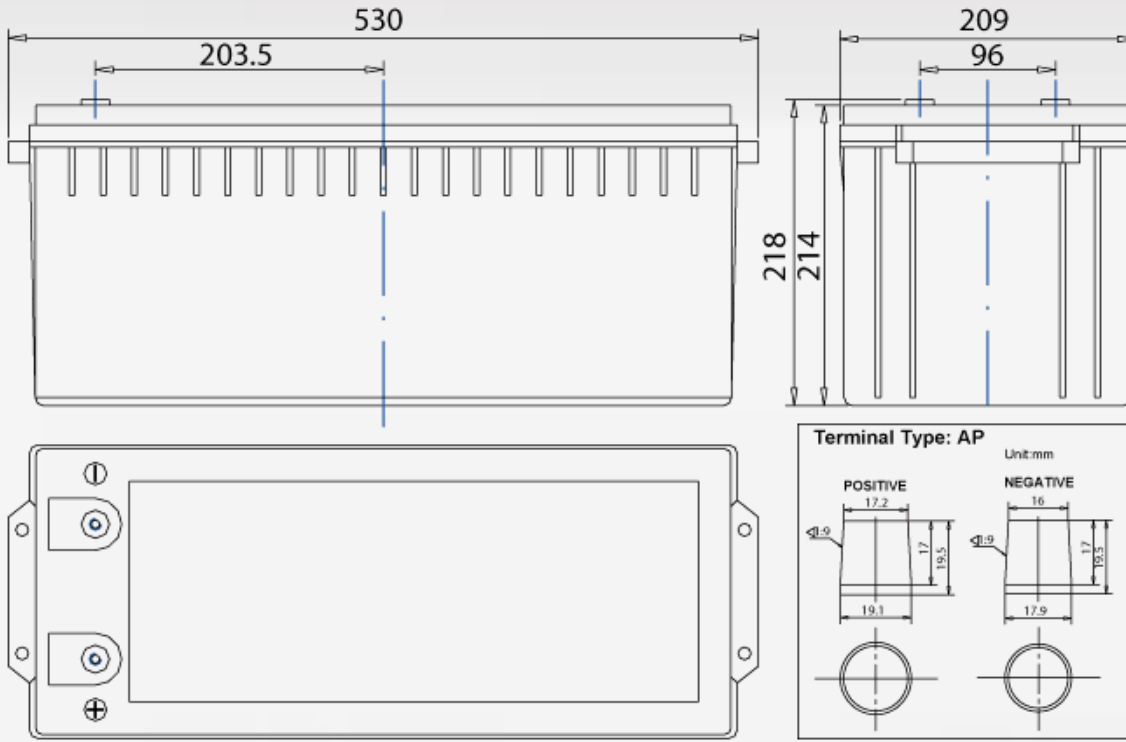

Discharge Curves

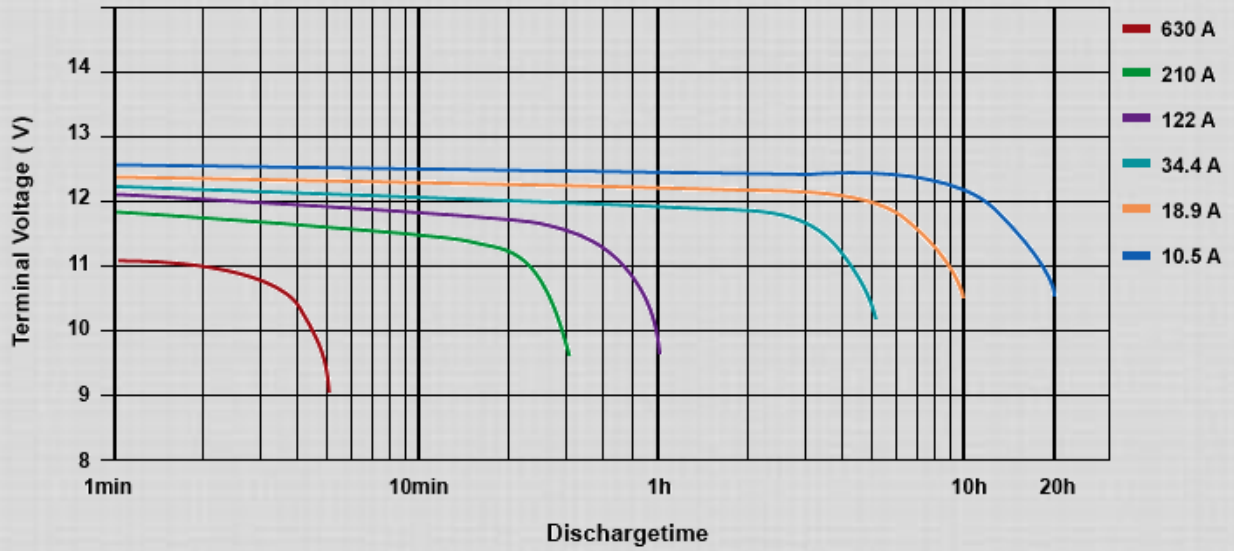

Individual results may vary