

Maßtoleranz: ± 2 mm

Art. Nr.: **SB.P45**

Bezeichnung: **P45**

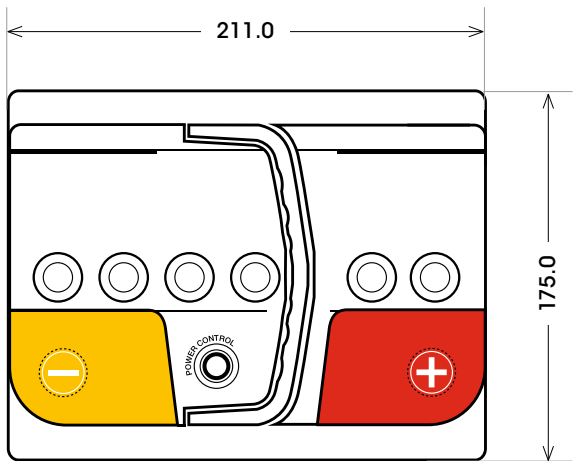
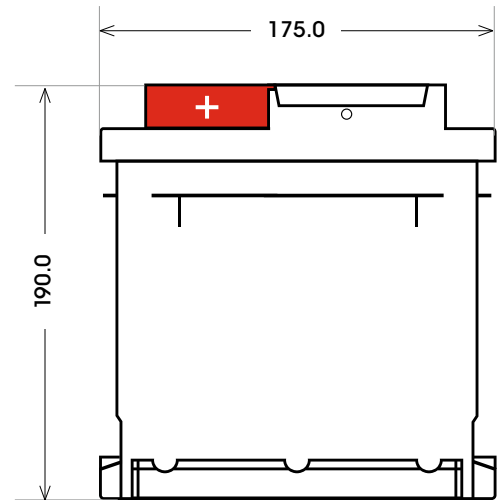
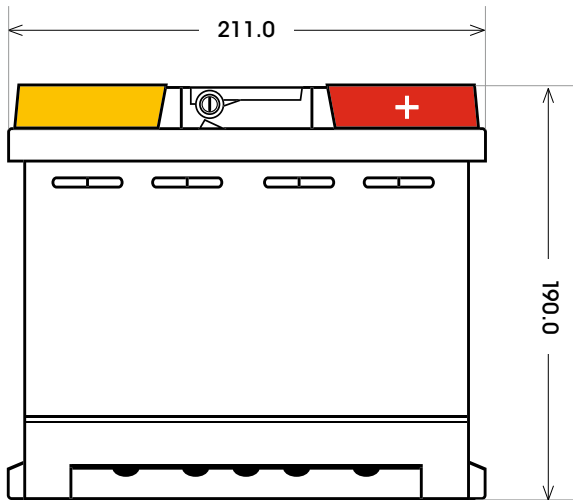

| | |
|----------------|--------------------|
| Technologie | Ca/Ca Nassbatterie |
| Spannung | 12 Volt |
| Kapazität | 45 Ah |
| Kälteprüfstrom | 450 A/EN |
| Länge | 211 mm |
| Breite | 175 mm |
| Höhe | 190 mm |
| Bodenleiste | B13 |
| Schaltung | 0 |
| Polart | 1 |
| Gewicht | 13.5 kg |

Bodenleiste **B13**

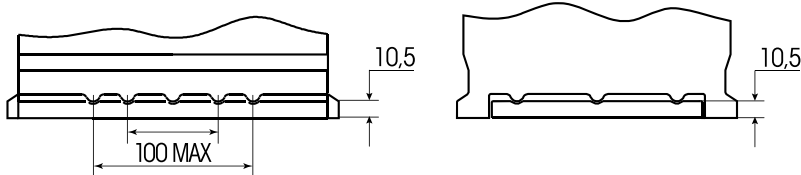

Schaltung **0**

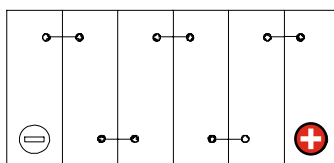

Anschlusspole **1**

