

Maßtoleranz: ± 2 mm

Art. Nr.: **MB.5101377**

Japan Nr.: **CTX12A-BS**

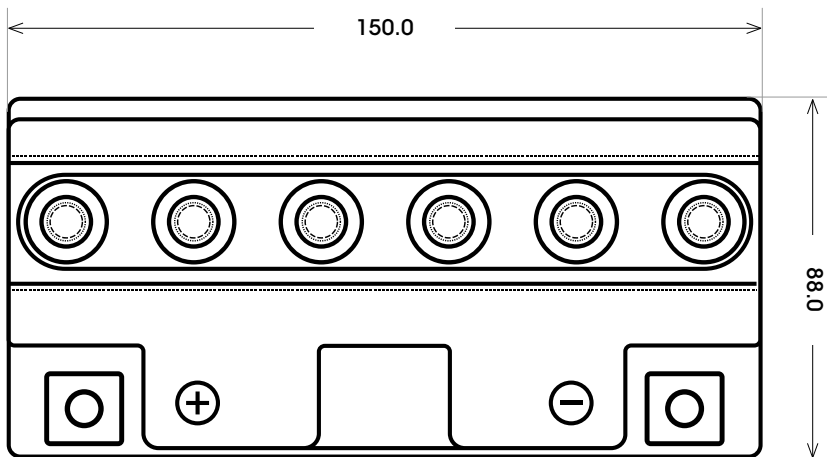
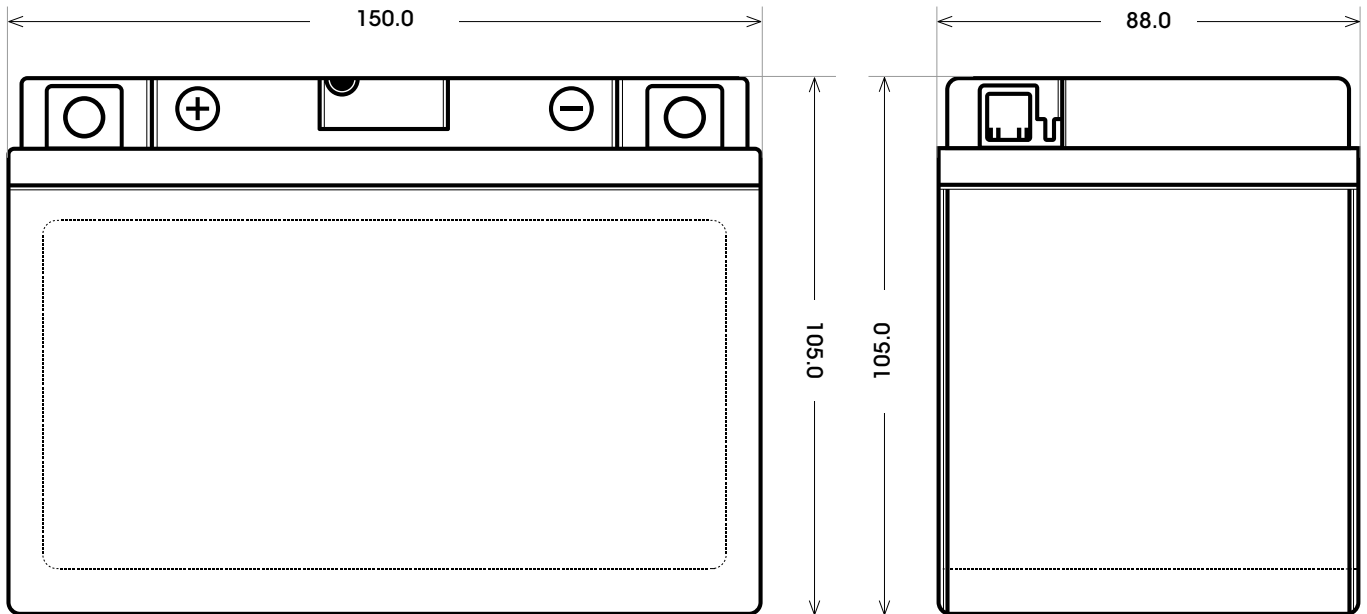

| | |
|-------------|-----------------|
| Technologie | AGM |
| Spannung | 12 V |
| Kapazität | 10 Ah |
| Kaltstart | 160 A/EN |
| Länge | 150 mm |
| Breite | 88 mm |
| Höhe | 105 mm |
| Schaltung | 1 (+ Pol links) |
| Polart | Y5 |
| Bodenleiste | B00 |
| Gewicht | 3.6 kg |

Bodenleiste **B00**



Schaltung **1**

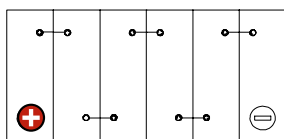

Polart **Y5**

