

Maßtoleranz: ± 2 mm

Art. Nr.: **MB.5031177**

Japan Nr.: **CB2.5L-C-2**

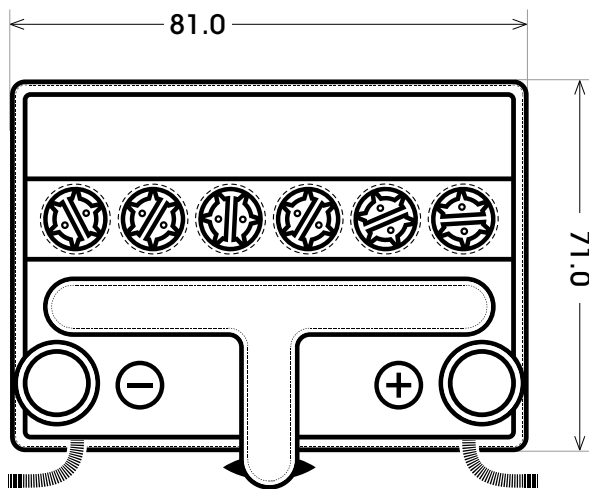
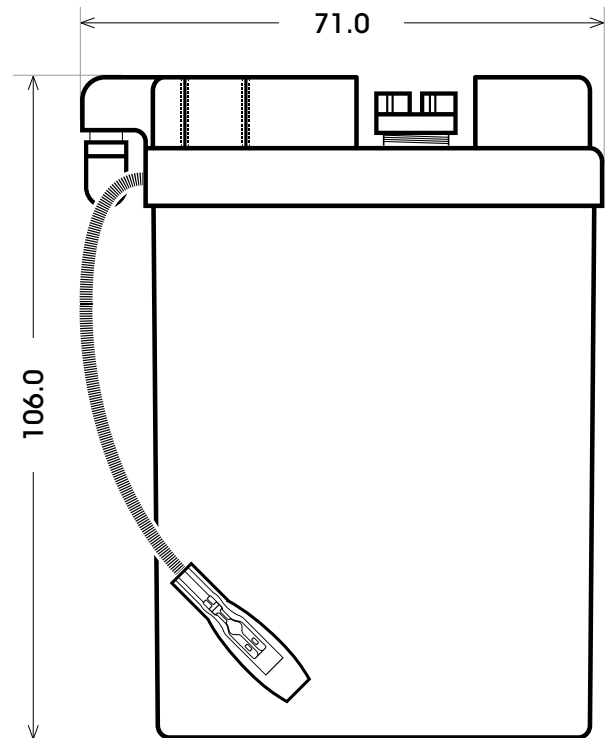
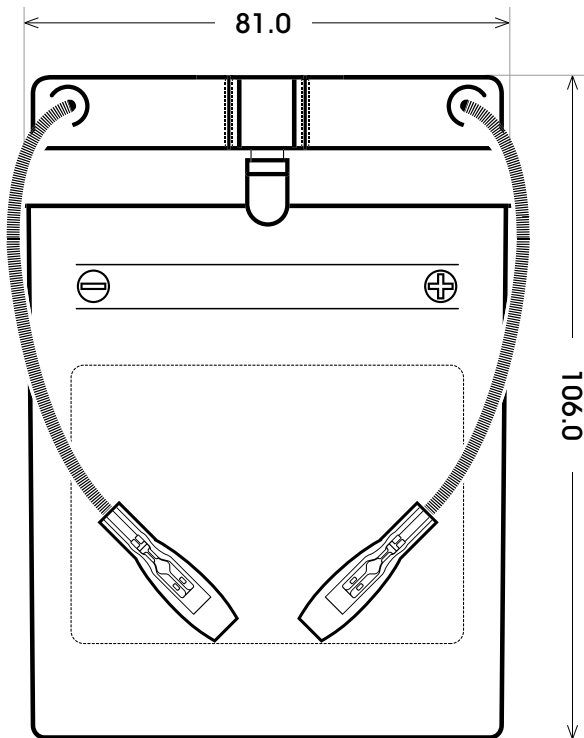

Technologie	RF - rüttelfest
Spannung	12 V
Kapazität	3 Ah
Kaltstart	10 A/EN
Länge	81 mm
Breite	71 mm
Höhe	106 mm
Polart	K
Schaltung	0
Bodenleiste	0
Gewicht	1.2 kg
Zustand	trocken vorgeladen

Bodenleiste **B00**

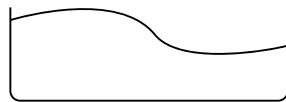

Schaltung **0**

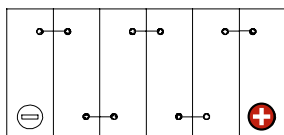

Anschlusspole **K**

