



Grip-Tite® Manufacturing Company, LLC

115 W. Jefferson Street

Winterset, Iowa 50273

Tel (515) 462-1313

Fax (515) 462-3465

Steve@griptite.com

www.griptite.com

Grip-Tite® Helical Pile Foundation System

CSI Section:

31 63 00 Bored Piles

1.0 RECOGNITION

Grip-Tite® Helical Pile Foundation System, manufactured by Grip-Tite® Manufacturing Company, LLC, was evaluated for use to underpin or stabilize existing structures and for use in new construction in place of micropiles and/or other deep foundation systems. The building structural loads are transmitted axially through the system, either in compression or in tension, to bearing soils via the system helices.

The structural and geotechnical properties of the Helical Pile Foundation System were evaluated for compliance with the following codes:

- 2018, 2015, 2012 and 2009 International Building Code® (IBC)

The Grip-Tite® Helical Pile Foundation System complies as helical piles in accordance with Section 1810.3.1.5 of the IBC.

2.0 LIMITATIONS

Use of the Grip-Tite® Helical Pile Foundation System recognized in this report is subject to the following limitations:

2.1 The helical pile foundations shall be analyzed, designed, detailed, and installed as required by IBC Sections 1808 and 1810. Designs shall be prepared by a qualified design professional and submitted to the building official for approval. Analysis shall be in accordance with IBC Section 1604.4 and shall include a geotechnical investigation, if necessary, as set forth in IBC Section 1803. The design method shall be Allowable Stress Design (ASD) using the load combinations in IBC Section 1605.3, except that allowable stresses are not permitted to be increased as permitted by the material chapter of the code or referenced standards.

2.2 The spacing between helical plates shall not be less than 3D, where D is the diameter of the largest helical plate measured from the edge of the helical plate to the edge of the adjacent helical pile plate, or 4D, where the spacing is measured from the center to the center of the adjacent helical pile plates. Group efficiency effects shall be included in the analysis where the center-to-center spacing of axially loaded helical piles is less than three times the diameter of the largest helix plate at the depth of bearing, and where the center-to-center spacing of laterally loaded helical piles is less than eight times the least lateral dimension of the pile shaft at the ground surface.

2.3 The systems shall be limited to support of structures in IBC Seismic Design Categories A, B and C only. Use of the systems to support structures located in Seismic Design Categories D, E, and F, or located in Site Class E or F, is outside the scope of this report. Compliance with the provisions of IBC Section 1810.3.11.1 has not been verified and shall be determined by the designer for each installation.

2.4 Connection of the Grip-Tite® Helical Pile Foundation System to the supported structure shall be designed by a registered design professional. Use of the system to support concrete structures shall be limited to support of uncracked concrete.

2.5 The piles shall be laterally braced for stability as required by IBC Section 1810.2.2.

2.6 Settlement of the helical pile shall be determined by a registered design professional as required by IBC Section 1810.2.3.

2.7 The systems shall not be used in conditions that are indicative of a potential pile corrosion situation as defined by soil resistivity less than 1,000 ohm-cm, pH less than 5.5, soils with high organic content, sulfate concentrations greater than 1,000 ppm, landfills, or mine waste. Materials with different corrosion protection coatings shall not be combined in the same system. Systems shall not be placed in electrical contact with (shall be galvanically isolated from) structural steel, reinforcing steel, or any other metal building components.

2.8 Installation of the helical piles is subject to special inspection as required by 2018, 2015, and 2012 IBC Section 1705.9 or 2009 IBC Sections 1704.10.

3.0 PRODUCT USE INSTRUCTIONS

The manufacturer's published installation instructions, this evaluation report, and the applicable provisions of the building code shall be followed when installing this product.





Where there is a conflict between these documents, the most restrictive provisions shall govern. The manufacturer's instructions and this report shall be available at the jobsite during construction for use by installers and for quality assurance.

Design and installation shall be completed in accordance with the rules and regulations of the authority having jurisdiction. Local codes and practices shall be followed in regard to obtaining appropriate engineering reports and designs, arranging for appropriate oversight, and obtaining building permits commensurate with the extent of the work to be completed.

3.1 Design

3.1.1 General: When required by the building official and when appropriate for the extent of the work to be completed, engineering reports, calculations, and designs shall be submitted. The Allowable Strength Design (ASD) method shall be used, as defined in IBC Section 1602 and the Glossary of AISC 360. Structural analysis shall account for all internal forces (shear, bending moments and torsional moments, as applicable) resulting from the applied loads, load eccentricity and maximum spans between piles.

The foundation design documentation shall include the following, in addition to other required data, for each pile assembly: assembly description and identification of each component of the assembly by model number and description; minimum embedment and torsional resistance termination criteria; design information and details for bracket installation including, where appropriate, details of bracket connection to structure, type and condition of structure to be supported, drill holes, bolts, washer plates, field welds, minimum concrete cover, concrete reinforcement, and leveling grout; the recommended angle of shaft installation and maximum permissible departure from that angle shall be specified for each bracket.

The tabulated capacities of the helical pile systems shall be used to select appropriate helical pile foundation assemblies to support the design loads. For helical pile foundation systems subject to combined lateral and axial loads, the required strength under combined loads shall be determined using the interaction equation prescribed in Chapter H of AISC 360. The pile minimum embedment depth for various loading conditions shall be included and shall be based on the most stringent requirements of the following: engineering analysis, tested conditions described in this report, the site-specific geotechnical report, and site-specific load tests. The minimum soil embedment depth for a pile in compression shall be 5 feet (1524 mm) from the structure to the upper most helix. For vertical or battered piles in tension applications, the pile shall be installed such that the minimum depth from the ground surface to the uppermost helix is 12 times the diameter of the largest helix.

The overall capacity of each Grip-Tite® helical pile (in tension and compression) is equal to the capacity of the weakest component or link in the helical pile load path. The four primary structural elements associated with the helical foundation system; Bracket Capacity (P1), Shaft Capacity (P2), Helix Capacity (P3) and Soil Capacity (P4); shall be compared to determine the allowable capacity of each individual helical pile. The allowable capacity shall be the lowest allowable capacity of the four primary elements but shall be limited to no more than 60 kips (267 kN).

3.1.2 Bracket Capacity (P1): The capacity of the supported concrete foundation shall be verified and/or designed and justified to the satisfaction of the code official. The design shall consider eccentricity of applied loads, including reactions of the brackets acting on the supported concrete foundation. Only localized limit states including (two-way) punching shear and concrete bearing, have been evaluated in this report. All other limit states described in ACI 318-14 Chapter 17 (2015 IBC) or ACI 318-11 Appendix D (2012 and 2009 IBC) for anchorage to concrete (breakout, pullout, and pry-out) shall be considered in design. The design shall include reactions provided by the brackets acting on the supported concrete foundation. Tables 5 and 6 of this report include selected allowable capacity ratings for the Standard Duty (retrofit) Bracket and New Construction Bracket, respectively.

3.1.3 Shaft Capacity (P2): Piles shall be braced in accordance with IBC Section 1810.2.2. The unbraced length of a pile, in accordance with Sections 1810.2.1, includes the length of piles standing in air or fluid, plus an additional embedded depth depending on the soil stiffness. The soil stiffness shall be quantified by the Standard Blow Count characteristics determined in accordance with ASTM D1586 (Standard Penetration Test). The maximum design loads shall not exceed the allowable capacities for fully braced conditions shown in Tables 3, 5 and 6. Where portions of the shaft are standing in air, water, or fluid, pile capacity shall be determined by a design professional.

3.1.4 Helix Capacity (P3): The load capacity (P3) for each of the 8-inch, 10-inch, 12-inch and 14-inch-diameter helices is 55 kips (245 kN), for both compression and tension. The capacities are additive for shafts with multiple helices.

3.1.5 Soil Capacity (P4): Soil capacity for site-specific conditions shall be determined by a registered design professional in accordance with Items 1 and 3 of IBC Section 1810.3.3.1.9, and considering groundwater and other geotechnical conditions. The design shall be based on soil resistance using the soils investigation report, the individual helix bearing capacities, and torque correlation factors from field qualification loading tests. The predicted load capacities shall be confirmed during pier installation. Combined lateral and axial capacity for soil is outside the scope of this evaluation report.



Soils investigation reports, when required, shall be submitted to the code official as part of the submittal documents required by IBC Section 107. The geotechnical report shall include the following (as applicable):

1. A site plan showing the location of the soil investigation (soil test borings, test pits, etc.)
2. A record of the soil boring logs and the laboratory test results from the soil samples obtained.
3. The soil profile.
4. The present and anticipated seasonal high groundwater tables, anticipated frost depth and corrosion-related parameters, as described in Section 2.7 of this report.
5. Soil properties of the major soil types encountered, that affect the design of the piles, and relative pile support conditions as defined in IBC Section 1803. These may include soil shear strength (i.e. wet unit weight, buoyant unit weight, cohesion, adhesion, un-drained shear strength, and internal friction angle) effecting the design and support conditions of the piles, as well as estimates of ultimate allowable soil bearing pressures, helical pile capacities and anticipated pile total and differential settlements.
6. A statement concerning the suitability of helical pile foundation system for the specific project.
7. Recommendations and data for the pile designer concerning soil strengths, existing loads adjacent to the installed pile, and any likely differential settlement.
8. Recommended center-to-center spacing of the helical piles, and any reduction of allowable loads due to the group action, if necessary.
9. Requirements for field inspection.
10. Pile testing requirements.
11. Any questionable soil characteristics and special design provision.

When appropriate for projects consisting of stabilizing existing low-risk, lightly loaded structures, the pile capacity may be estimated using the torque correlation method along with load testing to determine an adequate allowable pile capacity in lieu of site-specific soil investigations. Each helical pile installed using the torque correlation method shall be load tested or pre-loaded to at least two times the estimated required pile capacity to reduce the risk of excessive post-installation settlement.

With the individual helix bearing method, the total nominal axial load capacity of the helical pile is determined as the sum of the individual areas of the helical bearing plates times the ultimate bearing capacities of the soil or rock comprising the respective bearing strata for the plates.

The design documentation shall include the derivation of the design allowable capacity and the minimum effective torsional resistance pile termination criterion, derived using the torque correlation method. The axial load capacity based on the torque correlation method shall be determined as

follows:

$$Q_{ult} = K_t(T) \quad (\text{Eq 1})$$

$$Q_{all} = 0.5(Q_{ult}) \quad (\text{Eq 2})$$

Q_{ult} = Ultimate axial capacity of the helical pile in lbf (N), in tension or compression.

Q_{all} = Allowable axial capacity of the helical pile in lbf (N), in tension or compression, using a safety factor (F.S.) of 2.

K_t = For the RDS2875 2⁷/₈-inch (73 mm) round shaft helical piles, maximum torque correlation factors of 9 ft⁻¹ for compression and 7 ft⁻¹ for tension shall be used.

T = Effective torsional resistance, which is defined as follows: For single-helix piles supporting axial compression loads, it is the installation torque measured when the pile reaches its final tip embedment; for all piles supporting axial tension loads and for multi-helix piles supporting axial compression loads, it is the average of the last three installation torque measurements. Such torque measurements, in-lbf (N-m), shall be made at 1 foot (305 mm) increments of tip embedment as the lead helix moves from a position that is 2 feet (610 mm) prior to the final tip embedment.

The design allowable axial load shall be determined by dividing the total ultimate axial load capacity predicted by the individual helix bearing method, field loading tests method, or the torque correlation method by a safety factor of at least 2.

3.1.6 Shaft Lateral Capacity: The lateral capacity of the RDS2875 piles referenced in Table 7 of this report is based on field testing of the pile shafts with a single 8-inch diameter helical plate installed in a very stiff clay soil having an average Standard Penetration Test blow count of 20 bpf, at a minimum embedment depth of 15 feet (4.5 m). For soil capacity for lateral resistance in soil conditions substantially different than cohesive soils exhibiting an average SPT blow count of 20 bpf, the lateral capacity of the pile shall be designed by a registered design professional on a case-by-case basis.

3.1.7 Shaft Elastic Shortening and Lengthening: Elastic shortening or lengthening of a Grip-Tite® RDS2875 helical pile shaft may be a significant contributor to overall pile head movement under load for long piles. For loads up to and including the allowable load limits found in the tables of this report, the length change may be estimated as:

$$\Delta_{shaft} = PL/AE \quad (\text{Eq 3})$$

Δ_{shaft} = Length change of shaft resulting from elastic shortening or lengthening, in (mm).

P = Applied axial load, lbf (N).

L = Effective length of the shaft, in (mm).

A = Cross sectional area of the shaft, in² (mm²), shown in Tables 1 and 2 of this report.

E = Young's modulus of the shaft, may be taken as 29,000 ksi (200,000 MPa).



The effective length of the shaft, L, may be approximated as the average of the distances from the point of load application to each helical plate.

Potential deformations due to elastic shortening, elastic lengthening and slip in couplers will not significantly affect the allowable axial loads as tabulated in Table A of this report. The designer is advised, however, to consider such deformations when determining serviceability on a case-by-case basis.

Table A

Potential Coupler Slip:		
Coupler slip (Compression or Tension)	Black	0.197 in/cplr
	Galv.	0.151 in/cplr
Potential Elastic Shortening/Lengthening of Shaft and Coupler:		
Shaft Shortening (Compression)	Black	0.00021 in/ft/k
	Galv.	0.00020 in/ft/k
Shaft Lengthening (Tension)	Black	0.00022 in/ft/k
	Galv.	0.00019 in/ft/k
Coupler Shortening (Compression)	Black	0.000054 in/cplr/k
	Galv.	0.000050 in/cplr/k
Coupler Lengthening (Tension)	Black	0.000062 in/cplr/k
	Galv.	0.000053 in/cplr/k

3.2 Installation

3.2.1 General: The pile systems shall be installed by Grip-Tite® approved and certified installers, and the foundation design documentation described in Section 3.1.1 of this report shall be utilized for installation quality control. The helical piles shall be screwed into the ground as specified in the construction documents and connected to the structure to provide foundation support. The piles shall be located and aligned both vertically and horizontally as specified in the approved plans and specifications. The piles shall be installed to the minimum torsional resistance and embedment depth specified.

The piles shall be installed using portable or machine-mounted rotary hydraulic motors capable of exerting a torsional moment at least 10 percent higher than the minimum required installation torque. Equipment capable of measuring the torsional resistance experienced by the pile during installation to an accuracy of ±10 percent shall be used.

The brackets shall be installed to connect the supported structures or foundation elements to the tops of the helical piles. If a galvanized product is used, field cutting and drilling shall be protected against corrosion. If the installation fails to meet the minimum criteria, the project specifications shall include provisions for an alternative design.

3.2.2 Field Quality Control: The following aspects shall be verified as part of the helical pile installation to help achieve a good quality result:

1. The helical pile sections shall be assembled as specified by the design documents.
2. The installation equipment shall be adequately aligned with the pile to avoid bending the shaft.
3. An axial force shall be exerted as the helical pile is screwed into the ground so that the pile travels approximately 3 inches (76 mm) into the soil in each revolution.
4. The rotational rate shall be 5 to 25 rpm.
5. The torque needed to screw a pile into the soil is an important measure for control of helical pile installation quality. Torque shall be measured using a calibrated torque indicator or hydraulic torque motor with a known pressure/torque correlation (other methods to measure torque, i.e. shear pins, dial gauges, etc. may be used at the discretion of the registered design professional and if approved by the code official.) The following torque parameters shall be adhered to when installing the helical piles:
 - a. Torque shall be recorded at every 5 feet of installation depth.
 - b. Torque shall be recorded at final embedment (E_f) + 2 feet, (E_f) + 1 foot, and (E_f) for tension piles with only one helix and for piles with multiple helices.
 - c. The final embedment depth and torque shall meet the minimum specifications of pile design.
 - d. The final torque shall be taken as the average of the last three readings for piles with multiple helices.
 - e. The pile’s maximum installation torque rating listed in Table 3 of this report shall not be exceeded throughout installation.

3.2.2.1 FP3BA Standard Duty Bracket: The following aspects shall be verified as part of the installation of the Standard Duty Brackets to help achieve of a good quality result:

1. Notching the footing or grade beam is recommended to allow the bracket to mount directly and adjacent to the load-bearing wall or column. Altering the existing foundation, including the reinforcing steel, shall only be performed with the approval of the registered design professional and the code official.
2. The installation of concrete anchors shall be in accordance with the code and the applicable anchor bolt manufacturer’s recommendations.
3. The nuts shall be tightened so the all-thread rods achieve a snug-tight condition as defined in Section J3 of AISC 360 (as a minimum, nuts shall be tightened to one-quarter turn beyond hand-tight condition).
4. Any lifting or stabilizing of the structure shall be under the supervision of a qualified registered design professional to ensure that no part of the foundation, structure, or helical pile is overstressed.
5. The excavation shall be backfilled with properly compacted soil.



6. If the pile system is designed to resist uplift forces, the pile may be attached to the bracket utilizing two optional holes factory drilled through the back side of the bracket sleeve. One or two $3/4$ -inch (19 mm) by 2-inch (51 mm) long high strength bolts are used to connect the bracket to the helical pile shaft. As an alternative, the holes could be plug welded to attach to bracket to the pile shaft if approved by the registered design professional and the code official.

3.2.2.2 NCB New Construction Bracket: The following aspects shall be verified as part of the installation of the New Construction Brackets to help achieve of a good quality result:

1. The helical pile sections shall be installed until the termination criteria prescribed in the foundation design documentation from Section 3.1.1 of this report are met and the top of the shaft is at or above the required elevation. The shaft shall be cut to the required height to provide the minimum concrete embedment depths into the footing or grade beam in Table 6 of this report and depicted in Figure 5 of this report shall be adhered to.
2. The new construction bracket shall be seated firmly.
3. Minimum concrete embedment depths for piles in compression and tension are listed in Table 6 of this report. Where the pile is used to resist tension forces, the bracket shall be bolted to the shaft with the bolts specified in Section 4.2.5 of this report. The nuts shall be tightened to snug-tight condition as defined in Section J3 of AISC 360 (as a minimum, nuts shall be tightened to one-quarter turn beyond hand-tight condition).
4. The steel reinforcing bars shall be placed and the concrete shall be poured according to the approved construction documents.
5. All helical pile components shall be electrically isolated from the concrete reinforcing steel and other metal building components.

3.3 Special Inspections: Special inspections shall be required in accordance with Chapter 17 of the IBC for helical pile foundations. The special inspector shall review all of the relevant design documentation including this evaluation report, the geotechnical report, and the construction documents prepared by the registered design professional in responsible charge to make sure the proper installation procedures are used and to determine compliance. Specific items to be inspected include installation equipment used, pile dimensions, tip elevations, final depth, final installation torque, and bracket configuration and dimensions. Where site welding takes place, special inspection in accordance with 2015 and 2012 IBC Section 1705.2 or 2009 IBC Section 1704.3 shall be required. Additionally, the special inspector shall verify the documentation showing that the installer is recognized by

the manufacturer; the product is assembled and installed as specified in the designs; the manufacturer's installation instructions are followed; the installation angle is as specified in the designs; and the pile and the supported structure are adequately connected to transmit the loads.

4.0 PRODUCT DESCRIPTION

4.1 General: The Grip-Tite® Helical Pile Foundation Systems consist of helical plates welded to the outside of steel tubing to form helical piles that are screwed into the ground until the design soil strata or design penetration resistance is reached. Extension sections are often required to advance the lead section to a soil deep enough to provide adequate soil bearing in accordance with project requirements. The structure to be supported is fastened to the tops of the helical piles using brackets described in Section 4.2.4 of this report.

4.2 Components

4.2.1 RDS2875 Lead Sections and Extensions: The lead and extension sections consist of $2\frac{7}{8}$ -inch (73 mm) outside-diameter (OD) structural steel tubing having a minimum nominal shaft wall thickness of 0.262-inch (6.65 mm). The sections are joined together by placing the coupler, which is at the leading end of each extension, over the shaft at the trailing end of each section, and pinning these ends together using three $3/4$ -inch (19.1 mm) standard hex cap screws as described in Section 4.2.5 of this report. Figure 1 and Table 1 of this report address dimensions and details of lead sections, and Figure 2 and Table 2 of this report provide dimensions and details of extension sections. The lead sections and extensions are made of carbon steel round structural tubing conforming to ASTM A500, Grade B specifications, having a minimum yield strength of 50 ksi (345 MPa) and a minimum ultimate tensile strength of 58 ksi (400 MPa). The complete lead and extension sections are offered uncoated or with an optional galvanized coating complying with ASTM A123.

4.2.2 RDS2875 Helical Plates: The helical plates are cut from $3/8$ -inch-thick (9.53 mm) steel plate and have outer diameters of 8-, 10-, 12-, or 14-inches (203 mm, 254 mm, 305 mm, or 356 mm). The plates are deformed using a hydraulic press and die to achieve a 3-inch, $\pm 1/4$ -inch (76.2 mm, ± 6.4 mm) helical pitch. The helical plates are welded to the outside of the steel tubing of the lead and extension sections using a $1/4$ -inch (6.35 mm) fillet weld in accordance with the manufacturer's approved quality control system as required to form the models listed in Tables 1 and 2 of this report. The plates are made of carbon steel conforming to ASTM A36, having a minimum yield strength of 36 ksi (248 MPa) and a minimum ultimate tensile strength of 58 ksi (400 MPa).



4.2.3 RDS2875 Couplers: The couplers are made by welding 7-inch (178 mm) lengths of 3¹/₂-inch (89 mm) OD HSS structural steel tubing having a nominal shaft wall thickness of 0.300 inch (7.62 mm), to the leading ends of extension sections to form a bell-shaped attachment device. The couplers over-lap the extension tubing by 1-inch (25.4 mm) and are welded in place using a 1/4-inch (6.35 mm) fillet weld. The couplers are made from ASTM A500, Grade B steel, having a minimum yield strength of 50 ksi (345 MPa) and a minimum ultimate tensile strength of 58 ksi (400 MPa).

4.2.4 Brackets: Brackets are used to connect the supported structures or foundation elements to the tops of the helical piles. The brackets are made from steel plate and round structural steel tubing assembled in accordance with the manufacturer's approved quality control manual. The 3/8-, 1/2-, 3/4-, and 1-inch-thick (9.53 mm, 12.7 mm, 19.1 mm, 25.4 mm) steel plates used to make the brackets conform to ASTM A36 and have a minimum yield strength of 36 ksi (248 MPa) and a minimum ultimate tensile strength of 58 ksi (400 MPa). The standard duty retrofit bracket tubes consist of structural steel tubing conforming to ASTM A513, Type 5 Grade 1026 specifications having a minimum yield strength of 70 ksi (483 MPa) and a minimum ultimate tensile strength of 80 ksi (552 MPa). The new construction bracket tubes consist of HSS structural steel tubing conforming to ASTM A500, Grade B specifications having a minimum yield strength of 50 ksi (345 MPa) and a minimum ultimate tensile strength of 58 ksi (400 MPa). The brackets are described in Sections 4.2.4.1 and 4.2.4.2 of this report. All completed welded bracket assemblies are offered with an optional galvanized coating complying with ASTM A123.

4.2.4.1 GTFP3BA Standard Duty Bracket: The Standard Duty Brackets (repair or retrofit brackets) are used at the tops of the lead or extension sections to underpin and support existing structures. The brackets have two 1/2-inch-thick (12.7 mm) steel plates welded together at a 90° angle to form a shelf to support the structure. The shelf is welded to a 12-inch-long (305 mm), 3/8-inch-OD (98 mm) by 3 1/8-inch-ID (79 mm) structural steel sleeve and a sleeve plate having dimensions of 5 inches (127 mm) by 9.5 inches (241 mm) by 3/4-inch (19.1 mm) thick. The horizontal plate or shelf is 10 inches (254 mm) wide by 8 inches (203 mm) deep. The vertical plate, used to fasten the bracket to the existing structure, is 14 inches (356 mm) wide by 10 inches (254 mm) in height. Two 3/8-inch-thick (9.5 mm) steel gusset wedges are welded between the sleeve and the underside of the shelf. An adjustable cap, having dimensions of 4 inches (102 mm) by 8 inches (203 mm) and 1-inch-thick (25.4 mm), attaches to the sleeve plate using two 3/4-inch (19.1 mm) all-thread rods with heavy hex nuts. The cap plate allows the bracket to be raised or lowered as necessary to the required height for the supported structure.

The vertical face of the repair bracket includes four 9/16-inch-diameter (14.3 mm) holes for use in connecting the bracket to supported concrete structures using concrete anchors, which are not supplied with the bracket assemblies. Anchors installed to support gravity, uplift, or lateral loads shall be designed by a qualified design professional and shall be galvanized in accordance with the recommendations of the designer and the anchor manufacturer for the application in which they are used.

4.2.4.2 GT2875-NCB New Construction Bracket: The New Construction Bracket is used to support new concrete foundation structures (grade beams, footings, or pile caps) where the bracket's bearing plate is cast into the concrete. The steel bearing plate is 4 inches wide by 8 inches long by 1 inch thick (102 mm by 203 mm by 25.4 mm). The plate is welded to a 3 1/2-inch-OD (89 mm) by 2.9-inch-ID (74 mm) by 7-inch-long (178 mm) steel coupling sleeve that fits over, and is bolted to, the top of a lead or extension section using 3/4 inch (19.1 mm) standard hex cap screws and matching standard hex nuts. The bracket transfers compression, tension, and lateral loads from the concrete foundation structure to the helical pile.

4.2.5 Threaded Rods, Bolts and Nuts: The 3/4-inch (19.1 mm) standard hex cap screws (bolts) used in joining the lead shafts and extensions and to connect the new construction brackets to the tops of the piles conform to SAE J429, Grade 8 specifications, having a minimum yield strength of 130 ksi (896 MPa) and a minimum ultimate tensile strength of 150 ksi (1034 MPa). The standard hex nuts used with the standard hex cap screws conform to SAE J995, Grade 8 specifications. The standard hex cap screws and matching standard hex nuts are zinc coated in accordance to ASTM F1941. The 3/4-inch (19.1 mm) all-thread rods and matching heavy hex nuts are used to attach the cap plate to the sleeve plate on the standard duty retrofit bracket. The all-thread rods conform to ASTM A193, Grade B7 specifications, having a minimum yield strength of 105 ksi (724 MPa) and a minimum ultimate tensile strength of 125 ksi (862 MPa). The heavy hex nuts conform to ASTM A194, Grade 2H, or ASTM A563, Grade DH specifications. The all-thread rods and heavy hex nuts are zinc coated in accordance to ASTM B633.

4.2.6 Welds: Factory welds used in the assembly of the helical pile plates, shafts, couplers, and brackets are completed in accordance with the product drawings and the manufacturer's approved quality control manual. Field welds are outside the scope of this report and shall be designed by a qualified design professional and inspected in accordance with 2018, 2015, and 2012 IBC Section 1705.2 or 2009 IBC Section 1704.3.



5.0 IDENTIFICATION

The Grip-Tite® Manufacturing Co., LLC Model RDS2875 Helical Foundation System components described in this report shall be identified by labels that include the report holder’s name (Grip-Tite® Manufacturing Co., LLC), the product catalog number and description, the name and address of Co-Line Welding, Inc.

Additionally, Model RDS2875 helical piles are identified by the prefix “RDS”, the Standard Duty Brackets are identified by the prefix “FP” and the New Construction Brackets are identified with “NCB”.

The evaluation report number (ER-391) the IAPMO Uniform ES Mark of Conformity shall be used to identify the products recognized in this report. A die-stamp label may also substitute for the label. Either Mark of Conformity may be used as shown below:

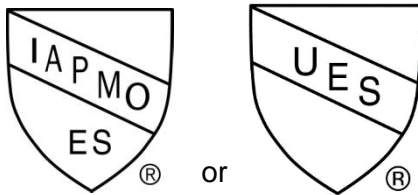

IAPMO UES ER-391

6.0 SUBSTANTIATING DATA

Data in accordance with the ICC-ES Acceptance Criteria for Helical Pile Systems and Devices (AC358), approved September 2017, editorially revised September 2018.

7.0 STATEMENT OF RECOGNITION:

This report describes the results of research carried out by the IAPMO Uniform Evaluation Service on Grip-Tite® Helical Pile Foundation System labeled in Winterset, Iowa, under the supervision of IAPMO UES, to assess its conformance to the codes and standards listed in Section 1.0 and serves as documentation of the product certification.

Brian Gerber, P.E., S.E.
Vice President, Technical Operations
Uniform Evaluation Service

Richard Beck, PE, CBO, MCP
Vice President, Uniform Evaluation Service

GP Russ Chaney
CEO, The IAPMO Group

For additional information about this evaluation report please visit www.uniform-es.org or email at info@uniform-es.org

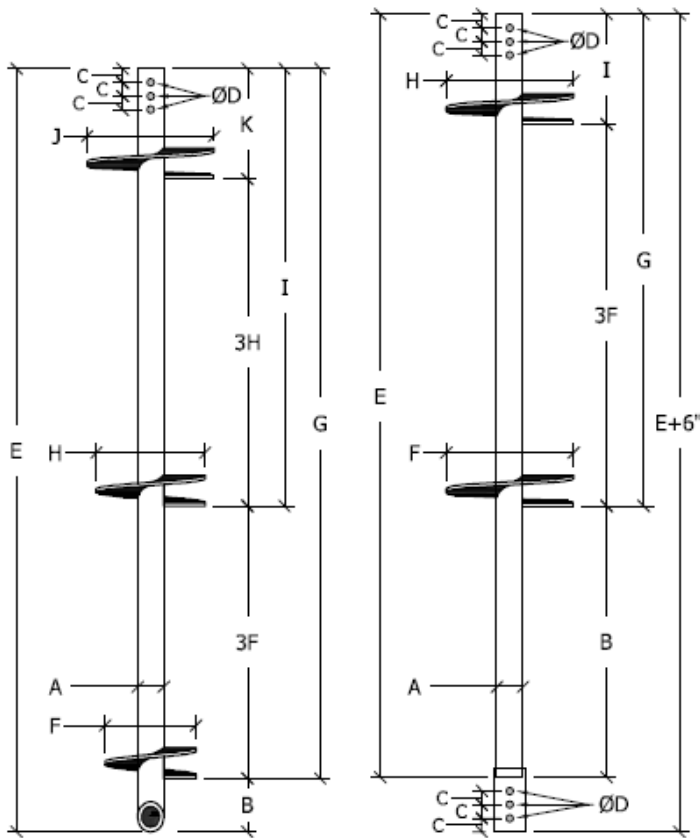

Figure 1.
RDS2875 Lead Sections

Figure 2.
RDS2875 Extensions

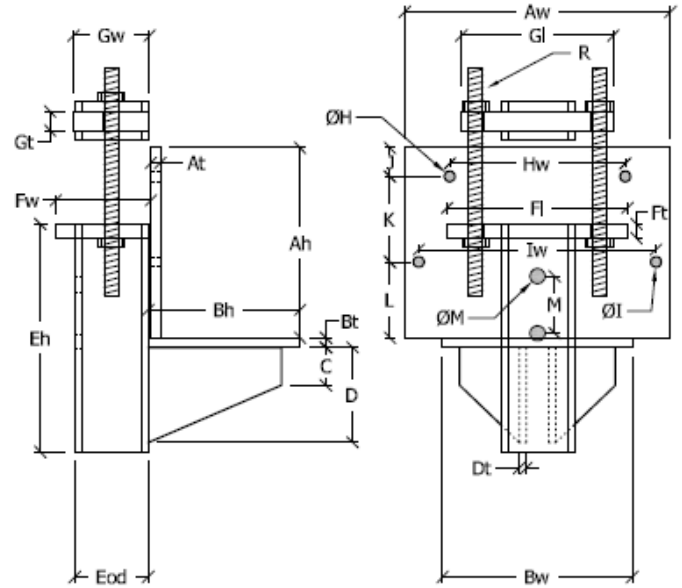

Figure 3. FP3BA
Standard Duty Remedial Repair Bracket

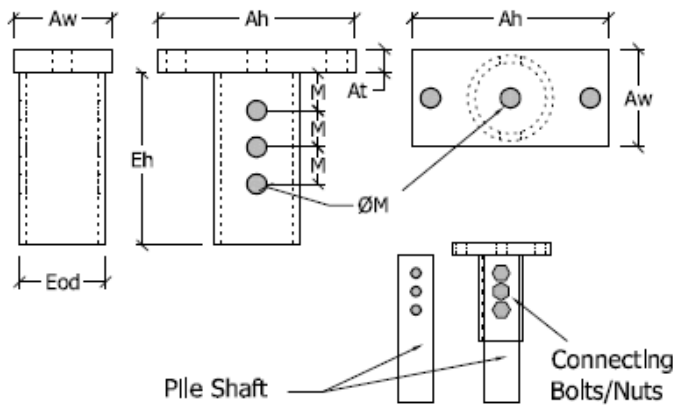

Figure 4. RDS2875-NCB
New Construction Bracket

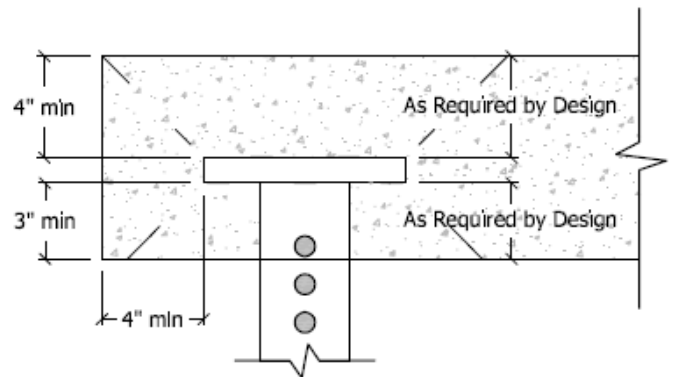

Figure 5. Grade Beam/Pier Cap with
RDS2875-NCB New Construction Bracket



Table 1
Dimensions of Typical Grip-Tite® RDS2875 Helical Pile Lead Sections by Product Catalog Number ³

Material ¹	Catalog Number ⁵	Shaft Cross-Sectional Area ² , (in ²)	Nominal Dimensions ³ , (in)												
			A ²	B	C	D	E	F	3F	G	H	3H	I	J	K
ASTM A500 Fy=50 ksi Fu=58 ksi	2LS8	1.72 (1.96)	2.839 (2.869)	5.875	1.5	0.8125 (13/16)	24	8	-	18.125	-	-	-	-	-
	2LS10						24	10	-	18.125	-	-	-	-	-
	2LS12						24	12	-	18.125	-	-	-	-	-
	2LS14						24	14	-	18.125	-	-	-	-	-
	5LS8						60	8	-	54.125	-	-	-	-	-
	5LS10						60	10	-	54.125	-	-	-	-	-
	5LS12						60	12	-	54.125	-	-	-	-	-
	5LS810						60	8	24	54.125	10	-	30.125	-	-
	5LS14						60	14	-	54.125	-	-	-	-	-
	5LS1012						60	10	30	54.125	12	-	24.125	-	-
	5LS1214						60	12	36	54.125	14	-	18.125	-	-
	7LS8						84	8	-	78.125	-	-	-	-	-
	7LS10						84	10	-	78.125	-	-	-	-	-
	7LS12						84	12	-	78.125	-	-	-	-	-
	7LS810						84	8	24	78.125	10	-	54.125	-	-
	7LS14						84	14	-	78.125	-	-	-	-	-
	7LS1012						84	10	30	78.125	12	-	48.125	-	-
	7LS81012						84	8	24	78.125	10	30	54.125	12	24.125
	7LS1214						84	12	36	78.125	14	-	42.125	-	-
	7LS101214						84	10	30	78.125	12	36	42.125	14	12.125

For SI: 1 inch = 25.4 mm; 1 in² = 645.2 mm²; 1 psi = 6.89 kPa; 1 ksi = 1,000 psi

Table 2
Dimensions of Typical Grip-Tite® RDS2875 Helical Pile Extensions by Product Catalog Number ⁴

Material ¹	Catalog Number ⁵	Shaft Cross-Sectional Area ² , (in ²)	Nominal Dimensions ⁴ , (in)											
			A ²	B	C	D	E	F	3F	G	H	3H	I	
ASTM A500 Fy=50 ksi Fu=58 ksi	3E	1.72 (1.96)	2.839 (2.869)	1.5	0.8125 (Ø13/16)	36	Plain Extensions							
	60					Plain Extensions								
	7E					Plain Extensions								
	3E14					36	14	-	24.125	-	-	-	-	
	5E14					60	14	-	48.125	-	-	-	-	
	5E14x					60	14	-	30.125	-	-	-	-	
	7E14					84	14	-	72.125	-	-	-	-	
	7E14x					84	14	-	54.125	-	-	-	-	
	7E1414					84	14	42	72.125	14	-	-	30.125	
	7E1414x					84	14	42	54.125	14	-	-	12.125	

For SI: 1 inch = 25.4 mm; 1 in² = 645.2 mm²; 1 psi = 6.89 kPa; 1 ksi = 1,000 psi

Footnotes to Tables 1 and 2:

- 1) Shaft and coupler material consists of round shaft structural tubing per ASTM A500, Grade B, minimum yield strength, Fy, of 50 ksi and minimum ultimate tensile strength, Fu, of 58 ksi. Helices are made from flat plate steel per ASTM A36, minimum yield strength, Fy, of 36 ksi and minimum ultimate tensile strength, Fu, of 58 ksi. Connection bolts are SAE J429 Grade 8, minimum yield strength, Fy, of 130 ksi and minimum ultimate tensile strength, Fu, of 130 ksi. The bolts are either zinc coated per ASTM B633 or ASTM B695, or galvanized per ASTM A153. The helical lead sections and extensions are either bare "black" steel or hot-dip galvanized per ASTM A123.
- 2) Bare or black steel dimensions (dimensions galvanized): Includes reduced dimensions for corrosion and a 50 year design life.
- 3) Figure 1 of this report illustrates dimensions.
- 4) Figure 2 of this report illustrates dimensions.
- 5) Galvanized product have a "G" suffix added to the end of the product's catalog number; i.e., 2LS8 is bare steel and 2LS8G is galvanized steel.



Table 3

Allowable Capacities⁴ and Recommended Maximum Installation Torque for Grip-Tite[®] RDS2875 Helical Piles^{1,2}

Product	Allowable Axial Capacity Limits ⁴ Bare Steel (Hot-Dip Galvanized)					Tension, (kips)	Shear, (kips)	Bending, (ft-k)	Recommended Capacity-Torque Ratio ⁴ , Kt, (ft ⁴)	Recommended Maximum Installation Torque ³ , T (ft-lbs)	Ultimate Torque Capacity, (kips) Qu=TKt	Allowable Torque Capacity ⁶ , (kips) Qu/2=Qa	
	Compression, (kips)												
	Unbraced Length, Lu ¹ (ft)	kLu=0	kLu=5	kLu=10	kLu=15								
ASTM A500, Gr B Fy=50 ksi Fu=58 ksi	0	55.5	18.1	8.2	4.4	32.1	16.7	2.52	Compression Kt = 9	9,000	81	40.5	
	Couplings ⁵	(60.0)	(19.9)	(9.0)	(4.8)								
	1	35.0	16.8	8.1	4.4	(37.7)	(18.4)	(2.76)	Tension Kt = 7	9,000	63	31.5	
	Coupling	(40.8)	(19.0)	(8.9)	(4.8)								
2	22.8	13.4	7.2	4.1									
	Couplings	(26.0)	(15.0)	(7.9)	(4.5)								

For SI: 1 inch = 25.4 mm; 1 ft-lbf = 1.356 N-m; 1 kip (1000 lbf) = 4.48 kN; 1 in² = 645.2 mm²; 1 psi = 6.89 kPa; 1 ksi = 1,000 psi

- Section 3.1.3 of this report provides the description of unbraced length, soft and firm soil conditions.
- Capacity ratings include an allowance for corrosion over a minimum 50 year service design life and presume the supported structure is braced in accordance with IBC Section 1810.2.2 and the lead section will provide sufficient helical capacity to develop the full shaft capacity. Section 3.1.2 of this report describes applicable limit states that shall be evaluated by a registered design professional.
- Maximum useable torque for calculating the pile's ultimate capacity using the equation $Q_{ult} = TKt$. Maximum torque applied to the helical pile anytime during installation should not exceed 9,495 ft-lb for the RDS2875 helical piles.
- The listed capacity-to-torque ratios may be adjusted to lower values on a case-by-case basis, if necessary. The listed allowable capacity includes a minimum Factor of Safety (FS) of 2. A higher Factor of Safety may be used to estimate the pile's allowable capacity on a case-by-case basis, if necessary.
- No eccentricity.

Table 4

Grip-Tite[®] Standard Duty and New Construction Bracket Dimensions by Product Catalog Number

Product ⁴	Aw Ah At ¹	Bw Bh Bt ¹	C D Dt	Eh Eod	Fl Fw Ft	Gi Gw Gt	Hw ØH Iw ØI	J K L	M ØM	R1 All-Threaded Rods/Bolts dia.-pitch x length ² , (in)	Concrete Anchors ³
	(in)	(in)	(in)	(in)	(in)	(in)	(in)	(in)	(in)		
FP3BA FP3BAG (Figure 3)	14 10 1/2	10 8 1/2	2 5 3/8	12 3-7/8	9.5 5 3/4	8 4 1	9.25 9/16 12.5 9/16	1.5 4.5 4	3 13/16	3/4 - 10 x 12 ASTM A193 Gr B7 and ASTM A194 2H Heavy Hex Nuts Fy = 105 ksi Fu = 125 ksi	Titen HD Screw Anchors, or equivalent 1/2" x 5.5"
RDS2875-NCB RDS2875-NCBG (Figure 4)	8 4 1	-	-	7 3-1/2	-	-	-	-	1.5 13/16	3/4 - 10 x 4-1/2 SAE J429 Grade 8	-

For SI: 1 inch = 25.4 mm; 1 psi = 6.89 kPa; 1 ksi = 1,000 psi

- Main plate dimensions in direct contact with supported foundation.
- 12-inch-long all-thread rods and nuts are provided with the remedial brackets. Longer or additional rods may be used if additional lift is needed, as necessary.
- Concrete anchors shall be provided by the installer; 1/2-inch-diameter concrete anchors may be used to fasten the remedial brackets in place. The brackets were tested with four post-installed Titen HD screw anchors fastened through the face of the bracket into the side of a concrete supported footing with a minimum 2,500 psi compressive strength. Anchors installed to support gravity, uplift, or lateral loads shall be designed by a registered design professional and installed in accordance to the manufacturer's recommendations.
- Figures 3 and 4 of this report show the FP3BA and NCB Brackets, respectively. Galvanized products include the suffix "G".



Table 5
Grip-Tite® Standard Duty Bracket Allowable Capacities by Product Catalog Number

Product ⁷	Main Plate Dim. ¹		RDS2875 ASTM A500 Fy = 50 ksi Fu = 58 ksi			All-Thread Rods ³	Concrete Anchors ^{5,6}
	Aw, Ah, At (in)	Bw, Bh, Bt (in)	Allowable Capacities ^{2,3,4,5} , (kips)				
			Comp., (kips)	Tension, ³ (kips)	Lateral, (kips)	dia. -pitch x length, (in) (R ₁)	
FP3BA FP3BAG	14, 10, 1/2	10, 8, 1/2	27	9.5, 19	10	3/4 - 10 x 12 ASTM A193 Gr B7 and ASTM A194 2H Heavy Hex Nuts Fy = 105 ksi Fu = 125 ksi	Titen HD Screw Anchors, or equivalent 1/2" x 5.5"

For SI: 1 inch = 25.4 mm; 1 kip (1000 lbf) = 4.48 kN; 1 psi = 6.89 kPa; 1 ksi = 1,000 psi

- 1) Main plate dimensions in direct contact with supported foundation.
- 2) Based on full scale load tests conducted using the Grip-Tite® Standard Duty Bracket (FP3BA). The allowable capacities include a minimum Factor of Safety (FS) of 2; a higher Factor of Safety shall be used on a case-by-case basis, if necessary.
- 3) Systems that require uplift capacities shall include two 3/4 -inch x 2-inch-long bolts thru the bracket tube sleeve into the existing shaft. One or two 3/4 inch diameter by 2-inch-long bolts may be installed. As an alternative, the bracket may be secured to the pile shaft by other means as directed by a registered design professional. Corrosion protection includes zinc coated per ASTM B633 or ASTM B695.
- 4) Fully braced foundation and shaft conditions.
- 5) Lateral capacities were tested using four Titen HD concrete anchors with a minimum embedment of 5 inches.
- 6) The brackets were tested with four post-installed Titen HD screw anchors fastened through the face of the bracket into the side of a concrete support with minimum 2,500 psi compressive strength. Anchors shall be designed by a qualified design professional and installed in accordance to the manufacturer's recommendations.
- 7) Figure 3 of this report depicts the Standard Duty Remedial Bracket, FP3BA. Galvanized product includes the suffix "G".



Table 6
Grip-Tite® New Construction Bracket Minimum Embedment Depths and Allowable Capacities
by Product Catalog Number

Product	Main Plate Dimensions ¹ , (in)	RDS2875			
		ASTM A500 Fy = 50 ksi Fu = 58 ksi			
		Aw A At	Minimum Concrete Cover Below (Tension) and Above (Compression) the Bracket Plate, (in)	Allowable Compression and Tension Capacities, (kips) ^{2,3,4}	Allowable Lateral Capacities, (kips)
2500 psi PCC	2500 psi PCC				
RDS2875-NCB	8	3	Tension	1.4	2.5
		4	Comp	8.2	
	4	6	Tension	8.2	
		8	Comp	14.8	
	1	8	Tension	14.8	
		10	Comp	23.0	
	12	Tension	23.0		
		12	Comp	32.9	
				40.0	

For SI: 1 inch = 25.4 mm; 1 kip (1000 lbf) = 4.48 kN; 1 psi = 6.89 kPa; 1 ksi = 1,000 psi

- 1) Main plate dimensions in direct contact with foundation.
- 2) The listed allowable capacities are limited by either the punching shear capacity of the grade beam, bearing or bending capacity of the bracket plate, the weld strength between the bearing plate and the bracket sleeve, or the shear capacities of the connecting bolts. The allowable capacities include a minimum Factor of Safety (FS) of 2. A higher Factor of Safety shall be used on a case-by-case basis, if necessary.
- 3) Systems that require uplift capacities shall include three ¾ inch diameter x 4½-inch-long bolts thru the bracket tube sleeve into the pile shaft. Bolt corrosion protection shall be zinc electroplated per ASTM F1941. As an alternative, the bracket may be secured to the pile shaft by other means as directed by a registered design professional.
- 4) Fully braced supported foundation and shaft conditions.
- 5) Figure 4 of this report depicts the New Construction Bracket, RDS2875-NCB. Galvanized products include the suffix "G".
- 6) Connection of the bracket to the foundation as it relates to resisting side loads due to seismic forces and the provisions found in IBC Section 1810.3.11.1, is outside the scope of this report.

Table 7
Lateral Load

Pile Type	Allowable Lateral Capacity (lbs)	Minimum Installation Depth (ft)
RDS2875	318	15

For SI: 1 inch = 25.4 mm; 1 kip (1000 lbf) = 4.48 kN; 1 psi = 6.89 kPa; 1 ksi = 1,000 psi

- 1) Installation shall be in accordance with Section 3.1.5 of this report. Installation is limited for use with new construction brackets. Minimum concrete edge distance to bracket plate is 4 inches.