

PURO™

UV Disinfection Lighting



UV Disinfection from Above

User Manual

Helo F1 Fixture

Single UV Light Engine

Helo F2 Fixture

Dual UV Light Engine

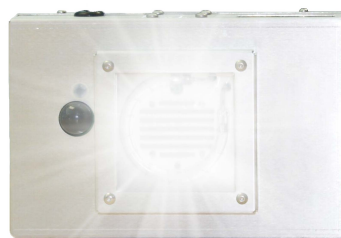

Which Products are Covered by this User Manual

Helo F1 / F1-12 / F1-24

Single UV Light Engine

The Helo F1 is a UV disinfection fixture with a single UV Light Engine. It can be installed in configurations for drop-in ceilings, recessed hard ceilings, or wall/surface mount and portable/tabletop use. All variants operate identically and have a 10' x 10' coverage area. This document will refer to this family as Helo F1.

This fixture can be integrated with a Building Automation System through BACnet or manually commissioned.

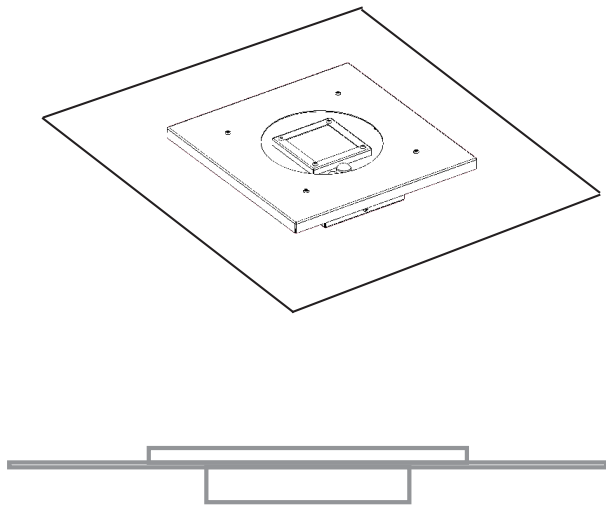

Note: The Helo F1-24 is shown with 24"x24" flange option attached for drop-in grid ceilings.

Other ordering configurations include:

Helo F1-12 with an integrated 12"x12" flange for recessed hard ceiling installations

Helo F1 for wall mount, surface mount or portable/table top use

Helo F2 Fixture

Dual UV Light Engine

The Helo F2 is a UV disinfection fixture with dual UV Light Engines. It can be installed in ceilings, suspended as a pendant, or wall mounted and has a 12' x 12' coverage area.

Like the Helo F1, this fixture can be integrated with a Building Automation System through BACnet or manually commissioned.

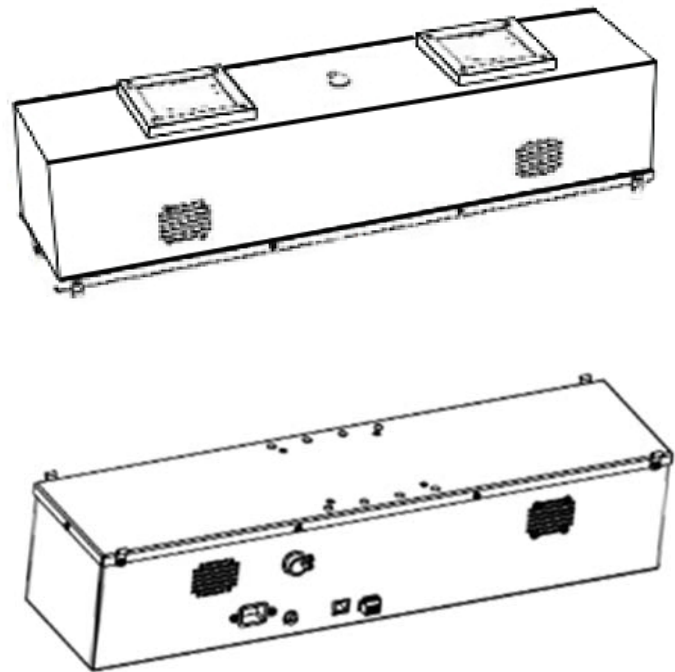

Safety Warnings



WARNING: TO REDUCE THE RISK OF FIRE OR ELECTRIC SHOCK, DO NOT EXPOSE THIS FIXTURE TO RAIN OR MOISTURE.

FC This device complies with Part 15 of the FCC Rules. Operation is subject to the following two conditions: (1) this device may not cause harmful interference, and (2) this device must accept any interference received, including interference that may cause undesired operation.

NOTE: This equipment has been tested and found to comply with the limits for a Class A digital device, pursuant to part 15 of the FCC Rules. These limits are designed to provide reasonable protection against harmful interference when the equipment is operated in a commercial environment. This equipment generates, uses, and can radiate radio frequency energy and, if not installed and used in accordance with the instruction manual, may cause harmful interference to radio communications. Operation of this equipment in a residential area is likely to cause harmful interference in which case the user will be required to correct the interference at his own expense.

CAUTION: TO REDUCE THE RISK OF ELECTRIC SHOCK, DO NOT REMOVE COVER. NO USER-SERVICEABLE PARTS INSIDE. REFER SERVICING TO QUALIFIED SERVICE PERSONNEL.

The lightning flash with arrowhead symbol, within an equilateral triangle is intended to alert the user to the presence of uninsulated "dangerous voltage" within the product's enclosure that may be of sufficient magnitude to constitute a risk of electric shock to persons.



Important Safety Notes

Read these instructions prior to operating the fixture. Keep and follow all instructions.

- Heed all warnings. Failure to use the equipment in the manner specified may impair the fixture from providing the desired protection.
- Plug fixture into a grounded outlet. Ensure proper conditions for operation. The fixture is designed to operate under normal conditions indoors (temperature 5-40 degrees Celsius, RH less than 80% (non-condensing), at an altitude <2000m and main supply fluctuations +/- 10% of nominal voltage, over voltage Category II.
- Allow fixture to complete pre-programmed cycles prior to unplugging or shutting off power. This allows it to enter safe mode.
- The Helo F1 is water resistant but not rated for direct spray down.
- Do not allow Helo F2 to get wet or use in or near water.
- Do not block any ventilation openings. Use in accordance with these instructions.
- Do not attempt to open or tamper with the fixture.
- Do not place or store the fixture near any flammable materials or liquids.
- Do not defeat the safety purpose of the polarized or grounding-type plug. A polarized plug has two blades and a third grounding prong. The wide blade or the third prong are provided for your safety. If the provided plug does not fit into your outlet, consult an electrician for replacement of the obsolete outlet.
- Protect the power cord from being walked on or pinched particularly at plugs, convenience receptacles, and the point where they exit from the fixture.
- Unplug this fixture during lightning storms or when unused for long periods of time.
- Refer all servicing to the manufacturer if there is any damage to the unit or it is not operating correctly.
- The fixture is designed to operate only when the room is unoccupied. There are redundant safety systems to ensure the fixture does not activate while the room is occupied as the UV light is not recommended for excessive exposure. If the sensor in the system fails, the system will shut down.
- Do not look directly at the fixture due to the brightness of the light. UV light does not significantly penetrate standard glass, therefore, incidental exposure on the other side of a window or wall does not present any significant risk.
- KEEP AWAY FROM CHILDREN

UV Safety Overview

Given the correct combination of user protocols and the built-in safety features of the Helo fixtures, there are minimal risks of any harmful effects from using the Helo fixtures.

Recommendations

- If in the vicinity of the Helo fixtures during operation, do not look directly at the light. This is similar to how one would avoid harmful effects from the sun by not looking directly at it.
- UV light does not significantly penetrate standard glass. It is safe to be behind a window or wall while the unit is operational.
- Per the built-in safety features described below, the unit is designed to not operate while a room is occupied. However, operators are instructed in the user manual to have all persons vacate a space before operation. Further optional protocols, such as signage indicating the UV unit is in operation may be desired.

Safety Features

The Helo fixtures have four primary aspects to their built-in safety features to ensure the safety of anyone operating or in the vicinity of a unit.

Limited Exposure Risk

Due to the nature of the programming on the Helo fixtures, over a 30-minute cycle time for the fixture, the actual exposure to UV (if there were no other safety systems in place) would be no more than two seconds of exposure.

Redundant Safety Systems

Each Helo fixture has a built-in passive infrared (PIR) sensor used to detect motion in a space. The sensor is programmed to detect individuals walking into the deployment space. The unit will not resume operation of the cleaning cycle until it has successfully detected the space is free of motion.

Safe Stop

The third layer of protection built into the Helo fixtures is to ensure that if the motion sensor or other components experience technical issues, the unit will safe stop by cycling the unit off. The unit will flash red indicating that one should contact PURO Lighting for technical support. The unit will not resume operation until the issue detected has been resolved. If unit is non-responsive (i.e. non-operational or no indicator light), contact PURO Lighting for technical support.

Frequency of Flashes

The Helo fixtures will flash every 6 seconds during operation. Violet Defense, PURO Lighting's technology partner, collaborated with the Epilepsy Foundation when designing the product to ensure that the frequency of flashes will not cause any issues for someone with photosensitive epilepsy.

Disclaimer: The Helo fixture is not intended for use as a medical device and people should not be directly exposed to the light generated by the unit. The actual disinfection rates on a specific space will vary.

Governmental Guidelines for UV Light Safety

Occupational Safety and Health Administration (OSHA)

The Occupational Safety and Health Administration (OSHA) does not have any mandated exposure limits to ultraviolet light. OSHA only provides technical guidance regarding protecting employees from ultraviolet laser exposure. While general information about ultraviolet contained in that guidance is described below, it is important to note that PURO Lighting does not currently deploy ultraviolet lasers. For more information on OSHA's guidelines, visit:

<https://www.osha.gov/laws-regs/standardinterpretations/2003-02-26>.

Ultraviolet radiation is divided into three regions: UV-A: 315-400 nanometers (nm), UV-B: 280-315 nm, and UV-C: 200-280 nm. UV can be associated with adverse health effects due to prolonged exposure and the wavelength of light.

According to OSHA's guidelines, "exposure in the shorter UV-C and longer UV-A ranges seems less harmful to human skin. The shorter wavelengths are absorbed in the outer dead layers of the epidermis and the longer wavelengths have an initial pigment-darkening effect followed by erythema if there is exposure to excessive levels."

"The hazards associated with skin exposure are of less importance than eye hazards." Exposure to light may cause photokeratitis or cataracts.

National Institute for Occupational Safety and Health (NIOSH)

The National Institute for Occupational Safety and Health (NIOSH) recommends limits to exposure determined by the wavelength of UV light and intensity. NIOSH recommends that the time of exposure to an intensity of 100 microwatts per square centimeter at wavelength 254 nm not exceed 1 minute. Per the programming, UV exposure from Helo fixtures for a 30-minute cycle is less than two seconds. For more information, view the recommended standards from NIOSH at:

<https://www.cdc.gov/niosh/docs/73-11009/pdf/73-11009A.pdf>.

Environmental Protection Agency (EPA)

The Environmental Protection Agency (EPA) is the governmental agency responsible for regulating ultraviolet light products. It regulates chemical disinfectants along with devices, such as equipment that generates UV light, used to control pests like bacteria and making antimicrobial claims. The manufacturer of PURO Lighting products is an EPA-registered company (Facility No. 92142) and is in full compliance with all regulations. For more information about EPA guidelines, visit:

<https://www.epa.gov/safepestcontrol/pesticide-devices-guide-consumers>.

Food and Drug Administration (FDA)

The Food and Drug Administration (FDA) only regulates devices that are classified as medical instruments, machines, and devices used to treat diagnosed medical conditions. Therefore, PURO Lighting does not fall under FDA guidelines. Furthermore, PURO Lighting products do use materials approved by the FDA for use in food and medical applications.

Manually Commissioned Helo Fixtures

Commissioning

Contact PURO Lighting or your PURO Lighting representative for assistance manually commissioning your Helo fixtures.

Operational Modes for Manually Commissioned Fixtures

Fixtures ordered for manual commissioning have three primary modes available to users. Fixtures must be programmed before initial use.

Autonomous Mode: In this mode, once plugged in, the fixtures will automatically activate once the space is unoccupied and continue disinfection on a regular schedule, adjusting frequency based on level of activity in the space based on the motion sensor. Users may select the timeout time, which determines how long the fixture will wait until resuming operation after motion is detected.

Scheduled Mode: In this mode, the fixture will activate at the selected time(s) of day during each 24-hour period. Users may schedule up to 4 start times each day to operate for a specified run time (i.e. 15 or 30 minutes). Users may select the motion timeout, which determines how long the fixture will wait until resuming operation after motion is detected. The fixture may also be configured to activate a disinfection cycle immediately when it is powered and then continue with the scheduled operational time(s).

Single Cycle Mode: In this method, users will manually activate the fixture to start a disinfection cycle. The fixture will then run its pre-programmed cycle (i.e. 15 or 30 minutes) one time before entering safe mode until power is cycled on and off again. Users may select the timeout time, which determines how long the fixture will wait until resuming operation after motion is detected.

Manually Commissioned Helo Fixtures

General Operation of Manually Commissioned Fixtures

1. The PURO Lighting Helo F1 and F2 fixtures are designed to be installed approximately 2 meters (~6 1/2 feet) away from priority areas. See page 12 for additional information on installation methods. Helo fixtures can effectively kill pathogens up to 4 meters (~13 feet) away, but the length of time necessary to run the fixture increases proportionately to the distance from targeted area. Reflective surfaces, including standard glass, will enhance the effectiveness of the fixture as the UV light will reflect off of these surfaces increasing their germ-killing effects.
2. The fixtures operate at 120V AC at 60 Hz. Once powered on, the fixtures will draw up to peak current for 4 second intervals (3.5amps for Helo F1 and 7amps for Helo F2). Ensure the breaker has available amperage during operation.
3. The space should be unoccupied during disinfection cycles. Exit the space within 60 seconds for optimal functioning of the fixture.
4. The fixtures' redundant safety systems will stop the fixture from operating if motion is detected in the space. The fixtures will resume operation approximately 60 seconds (unless alternate motion timeout was selected) after room is unoccupied and no additional motion is detected.
5. The fixtures will run a safety test to ensure proper functioning and that there is no motion detected in the space. If successful, fixtures will run their pre-programmed operational cycle. See guidelines for more information on operational modes.
6. Allow the fixtures to complete its entire cycle before unplugging or turning off power to the fixture. This allows the fixtures to enter safe mode.

BACnet Integrated Helo Fixtures

With the building automation system integration capabilities of the Helo fixtures, users have the ability to adjust the following:

- **Operational Modes & Settings:** Select operating modes, including type of disinfection cycle and related selections, such as start time, run time, and motion timeout length, which indicates how long the fixture will wait to attempt re-activation after motion has been detected
- **System Monitoring:** Monitor current status of fixtures remotely and troubleshoot operating
- **Network Settings:** Configure network settings and/or troubleshoot any networking issues
- **Metrics:** Access data on the fixtures, including number of successful cleaning cycles and runtime over specified period of time or lifetime of fixture

Helo fixtures integrated to BACnet for Building Automation Systems have five operating modes available to users that may be enabled and/or adjusted from your building automation control system (see pages 8-9 for additional information).

- **Automatic Mode:** The fixture will automatically activate once the space is unoccupied and continue disinfection on a regular schedule, adjusting frequency based on level of activity in the space based on the motion sensor.
- **Manual Mode:** User will manually activate the fixture to start a disinfection cycle. The fixture will then run its pre-programmed cycle length one time before entering safe mode until power is cycled on and off again.
- **Overnight Mode:** The fixture will activate a 30 minute disinfection cycle, turn off for 30 minutes, and then activate a second 30 minute disinfection cycle.
- **Four Hour Mode:** The fixture will run alternating 1 hour cycles of 2 minutes of cleaning, 8 minute breaks, followed by 30 minute break over the course of 4 hours. The cumulative cleaning time will be 36 minutes, but is intended to extend the life of the product.
- **BMS Mode:** The fixture will operate disinfection cycles similar to that of manual mode. However, the fixture will have to be activated from within your building automation system software.
NOTE: By default, this mode will have safety features deactivated, however the safety feature can be enabled in BACnet.

*Modes and settings are subject to change. Please contact the team at PURO Lighting if you have any questions.

Operational Modes and Settings

BACnet Variable	Description	Options
Operating Mode CMD	Set operating mode for the fixture. See descriptions on page 6.	AI; Manual; Overnight; Four Hour; BMS
Cleaning Internal Runtime STPT	Set the amount of time (in minutes) the fixture cleans for in manual mode.	Range 10 minutes to 120 minutes
Motion Timeout STPT	Sets the number of seconds for which the fixture will pause when it detects motion.	Range 15 seconds to 1,800 seconds
Enable Cleaning CMD	Manually turn the fixture on/off.	0 = fixture is off 1 = fixture is on
Enable Safeties CMD	When safeties are enabled, fixture pauses cleaning when PIR detects motion.	0 = Safeties are disabled 1 = Safeties are enabled
Cleaning Schedule	Fixture will start cleaning on any schedules set here. Synchronization of BACnet time with on-board clock is recommended. The schedule will repeat each week on the specified day and time.	Each day supports a maximum of 8 scheduled times.
Reboot Device CNFG	Reboots device	

System Monitoring

BACnet Variable	Description	Options
Real-Time Clean STS	Indication of fixture's cleaning cycle status	1= fixture finished a cleaning cycle 0 = fixture has not yet completed its current cleaning cycle
Motion Detected STS	Indication of status of PIR sensor	1 = fixture has detected motion 0 = No motion detected
UV Cleaning STS	Indication of fixture's current operational status	1 = fixture is running/cleaning 0 = fixture is not cleaning
Time Until Clean	Remaining time (in seconds) until the fixture is finished its current cleaning cycle	
Self Test STS	Reports any issues with the fixture that can be detected by on-board diagnostics	

Network Settings

BACnet Variable	Description	Options
DHCP CNFG	When DHCP is enabled, ethernet settings are acquired automatically. If the fixture fails to acquire a DHCP IP address, it will default to 192.168.1.5. When disabled, enter your custom settings via the IP Address, Subnet Mask, and Gateway Objects. Then reboot the device to apply network changes.	Enabled/Disabled
MSTP Baud Rate CNFG	Sets all network settings back to their factory defaults. Sets the MSTP baud rate back to the default (38400) and the MSTP MAC address to the default (55).	Supported device baud rates: 9600; 19200; 38400; 57600; 76800; 115200
IP Address CNFG	If DHCP is disabled, a static IP address can be set here.	
Subnet Mask CNFG	If DHCP is disabled, a static subnet mask can be set here.	
Gateway CNFG	If DHCP is disabled, a static gateway can be set here.	
Device MAC Address CNFG	The ethernet's MAC address	
UDP Port CNFG	The UDP port that BACnet uses.	Default value: 47808
MSTP MAC Address CNFG	Use this to set the MSTP MAC address. Each device on the network must have a unique MAC address.	Default value: 55

Metrics

BACnet Variable	Description
Successful Cleanings In Last 24 Hours	The number of cleaning cycles that were completed in the most recent 24-hour period
Runtime for Past 7 Days	Total run time (in hours) of the fixture over the past 7 days
Runtime for Past 30 Days	Total run time (in hours) of the fixture over the past 30 days
Total Runtime (Lifetime Hours)	Total run time (in hours) of the fixture over the product's life

Guidelines for Cleaning the Fixture

- Do not use abrasive cleaners to clean the unit.
- To clean the unit, wipe down the metal plates with stainless steel polish using a microfiber cloth.

General Disinfection Guidelines

For most situations, the general cleaning procedures can be used to operate the Helo fixtures. However, there are special instructions recommended for blood spills, or when certain organisms, such as *C. diff* are known or suspected to be present.

1. Complete standard cleaning procedures to remove any visible dirt, grease, or other debris from space.
2. Activate whole room unit per operational instructions above.
3. Upon returning to space, look at indicator light. Solid green light indicates cleaning cycle completed. If motion was detected prior to observing the indicator light, the indicator light will turn red. If users want to determine if the unit completed the last cycle, prior to powering off, stand out of range of the motion sensor for 60 seconds. The light will resume solid green if cycle was completed. Otherwise, it will resume operation.

Cleaning when Blood or Bodily Fluids are Present

UV light has the ability to penetrate liquid blood, which has not formed a dried crust, or bodily fluids up to a 1/16" thickness as long as there is no tissue or solid material present. Therefore, UV light may be used to help protect staff before and after traditional cleaning protocols for your facility.

1. Activate the Helo fixture prior to commencing any cleaning procedures. If the blood has already dried, apply hydrogen peroxide solution prior to running the unit.
2. Utilize normal procedures, including appropriate safety protocols to clean the space, including removal of blood and bodily fluids.
3. Activate a second cycle of the Helo fixture to target any remaining bacteria and viruses.

Cleaning when *C. diff* is of Concern

Clostridium difficile (*C. diff*) is a bacteria that is extremely difficult to kill (hence its name) as it is able to survive in unfavorable conditions. Furthermore, it is an anaerobic, endosporic organism, which means it can survive without oxygen and form dormant spores to survive harsh conditions. With the risk of severe illness associated with *C. diff*, it is recommended that you use a combination of approaches to reduce the risk of contracting *C. diff* in your facility.

1. Utilize your facility's adopted environmental cleaning and disinfection strategy for dealing with *C. diff*.
2. Activate the Helo fixture for two consecutive 30-minute cycles at a range of less than one meter for best results, or up to 2 hours for ceiling mounted units (must have a 30-minute break between two 60-minute cycles).

Troubleshooting

Sensor Indicators

Each Helo fixture has an indicator light that indicates the operational status of the unit.



Color of Light	Meaning
Flashing Green	Unit is ready to begin cleaning when room becomes unoccupied.
Solid Green	Unit has successfully completed its cleaning cycle. If unit detects motion, the unit will change to solid red, even if cycle completed.
Solid Red	Unit was interrupted during the cleaning cycle. Cleaning will resume when room becomes unoccupied again during the programmed times for operation.
Flashing Red	One of the safety sensors has detected an issue. Please see troubleshooting section for further information.

Troubleshooting

1. If the fixture is flashing red, then an issue was detected by the safety sensors. Unplug or power down the unit.
2. Plug the fixture back into the wall or turn on power to unit. Exit the space within 60 seconds.
3. When you return to the space, identify the color of light on the sensor indicator. If fixture is green or solid red, the fixture is working properly. If unit is still flashing red, contact PURO Lighting technical support.
4. If fixture is non-responsive (i.e. no indicator light showing), please contact PURO Lighting technical support.

Installations

Drop Ceiling (Helo F1-24 and Helo F2)

The Helo fixtures can be installed in 24"x24" or 24"x48" grid drop ceiling. The Helo F1 fixture is shipped with a 24"x24" flange kit when ordering the Helo F1-24. The Helo F2 fixture is 24" x 6" making it easy to cut into a ceiling tile. Ensure there is sufficient plenum space for airflow and fixture clearance.

1. Determine the placement in the room for optimal coverage.
2. Remove the existing ceiling tile.
3. Connect power to the Helo fixture. This may include:
 - A grounded non-GFI outlet/15 Amp or greater
 - A switched outlet
 - An outlet with a WiFi or Bluetooth-enabled Smartplug (App required)
4. Position the Helo fixture in the grid ceiling.
5. Insert cut-to-size ceiling tile to sit flush against the Helo fixture.
6. Turn on power to the device.

Cutting a Ceiling Tile to Size

Helo F1-24

1. If installing in a 24" x 24" Grid, no cuts are required
2. If installing in a 24" x 48" Grid, cut the ceiling tile to fit using a box cutter or appropriate tool.

Helo F2

1. Whether installing in a 24" x 24" or 24" x 48" Grid, measure and mark a 5 3/4" section to fit on the ceiling tile.
2. Use a box cutter or other appropriate tool to cut off the 5 3/4" section of the tile.

Hard Ceiling (Helo F1-12 and Helo F2)

1. Determine the placement in the room for optimal coverage.
2. Ensure there is no existing wiring, HVAC, plumbing, structural or other obstructions in the space above the intended installation area.
3. Measure the opening for the Helo F1-12 or Helo F2 fixture to be installed and carefully cut the ceiling opening.
4. Ensure there is a power drop to connect the fixture. This may include:
 - A grounded non-GFI 110V outlet/15 Amp or greater
 - A switched outlet
 - An outlet with a WiFi or Bluetooth-enabled Smartplug (App required)
 - Approved wiring to the fixture from the power panel of the junction box (permit may be required)
5. Mount the Helo fixture in the ceiling.
6. Turn on power to the device.

Installations

Suspended Pendant (Helo F2)

The Helo F2 fixture can be suspended from the ceiling to an appropriate height using standard lighting suspension wire. Ensure the ceiling or grid ceiling can support the weight of the Helo fixture.

1. Determine the placement in the room for optimal coverage to suspend the fixture at the desired height.
2. Ensure there is a power drop to connect the fixture. This may include:
 - A grounded non-GFI 110V outlet/15 Amp
 - A switched outlet
 - An outlet with a WiFi or Bluetooth-enabled Smartplug (App required)
 - Approved wiring to the fixture from a power panel or junction box (permit may be required)
3. Attach the Helo fixture to the suspension cables
 - If suspending a Helo F1 fixture, remove the 24"x24" flange first
4. Turn on power to the device.

Wall Mount (Helo F1 and Helo F2)

The Helo F1 and Helo F2 fixtures are equipped with attach points for a standard 100mmx100mm VESA wall mount hardware.

1. Determine the placement in the room for optimal coverage and mount the VESA bracket base
2. Ensure there is power available nearby to connect the fixture. This may include:
 - A grounded non-GFI 110V outlet/15 Amp
 - A switched outlet
 - An outlet with a WiFi or Bluetooth-enabled Smartplug (App required)
3. Attach the Helo fixture to the VESA bracket
4. Turn on power to the device.

Portable/Tabletop Use (Helo F1)

The Helo F1 can also be used as a portable or tabletop disinfecting UV light unit.

1. Determine the placement in the room for optimal coverage and ensure the surface is dry and stable
2. Plug in the unit into a non-GFI 110V outlet/15Amp
3. Turn on power to the device.

Technical Support

Email us at support@purolighting.com.