

SPECIFICATIONS

Applications:

The CT Cart narrow is designed to hold up to 6 round composite core tables from 42" to as large as 72" round. This cart is designed to fit through common doorways and into elevators.

The CT Cart wide holds the same size tables. However, it will hold up to 12 tables. This cart is 53 1/4" wide and, will not fit through a common door. You will need a double door system with at least a 55" opening.

Primary Structure:

The cart shall consist of a steel frame, and is designed to roll easily on 5", 6" or 8" rounded tread wheels with roller bearings. A handle is provided at the rear of the cart. The handle adjusts to accommodate tables from 42" to 72". The loading ramp is covered with neoprene rubber to guard against table edge wear.

QUICK SPECS

Cart Size	Width	Height	Length (handle in/out)	Weight
Narrow w/5" wheels	25 1/8"	41 5/8"	50 1/2"/60"	77 lbs
Wide w/5" wheels	47 7/8"	41 5/8"	54 1/4"/NA	99 lbs
Narrow w/6" wheels	30 1/2"	40 1/8"	50 1/2"/60"	88 lbs
Wide w/6" wheels	53 1/4"	40 1/8"	50 1/2"/60"	110 lbs
Narrow w/8" wheels	30 1/2"	41 1/8"	50 1/2"/60"	93 lbs
Wide w/8" wheels	53 1/4"	41 1/8"	50 1/2"/60"	115 lbs

Add these amounts to height & length dimensions to calculate loaded dimensions

Table	Length	Height
CT42	+1"	+3 3/8"
CT48	+4"	+10 1/16"
CT54	+7"	+16 1/4"
CT60	+10"	+22 3/8"
CT66	+13"	+28 9/16"
CT72	+16"	+34 3/4"

Part	Material Size
Main Rails	3"x 2" x 3/16" angle iron
Ramps Front & Rear	14 gauge (.083) sheet metal
Caster Plate	4" x 3/8" flat strap (.375)
Handle Material	1 1/4" x 14 gauge (.083) round tubing
Wheel Guards	3" x 3/16" (.188) flat strap

Wheel/ Casters:

5" (42-60) Caster Option: The wheels shall be 1 1/4" wide x 5" diameter, non-marring, flat tread, thermoplastic elastomer, with 3/8" ball bearings. Wheels shall be mounted on two swivel caster rigs with brakes and two fixed caster rigs. They shall have a load capacity of not less than 325 pounds each. These casters should not be used on wide carts loaded with CT66 or CT72 tables.

6" or 8" (42-72) Caster Option: The wheels shall be 2" wide x 6"/8" diameter, rounded, soft, thermoplastic elastomer, with straight roller bearings. The back wheels shall be contained in a swivel caster rig with brake. The casters and wheels shall have a dynamic load capacity of not less than 450 pounds each.

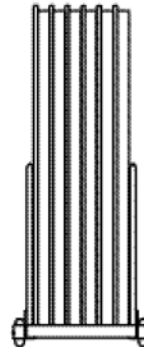
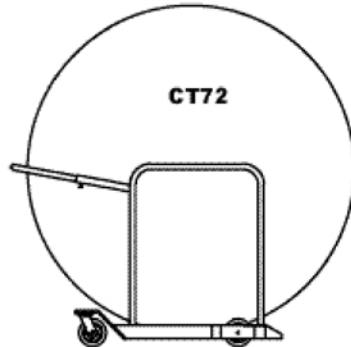

Part number example: (1st # after color is width 2=wide, 5=narrow; 2nd # is caster)

Narrow w/5" Caster=CRTCT42-60BLK55, Wide w/5" Caster=CRTCT42-60BLK25, Wide w/6" Caster=CRTCT42-72BLK26