

RT Cart – Double Capacity



the leader in lightweight durability

SPECIFICATIONS

Applications:

The RT Cart – Double Capacity is designed to hold up to 20 rectangular tables stacked flat on cart. A handle is provided at the swivel caster end of the cart allowing the user to steer the cart. Side rails are provided at each end of the cart to help hold the tables in place. The tables contain stacking buttons at each corner helping to keep them from sliding off of each other.

QUICK SPECS

Cart Size	Width	Height	Depth	Weight
3060	31 ¹ / ₄ "	66"	64"	75 lbs.
3072	31 ¹ / ₄ "	66"	76"	80 lbs.
3096	31 ¹ / ₄ "	66"	100"	91 lbs.

Primary Structure:

Part	Material Size
Main Frame	bent and punched 14 gauge (.083) steel sheet metal
Handle Sockets	1 1/4" x 11 gauge (.120 wall) round tubing
Handles and Side Rails	1" x 14 gauge (.083 wall) round tubing

Casters:

The wheels shall be not less than 1 1/4" wide x 5" diameter, non-marring, flat tread, thermoplastic elastomer, with 3/8" ball or roller bearings.

The RT3060 and RT3072 Double Capacity carts shall have wheels mounted on two swivel caster rigs and two fixed caster rigs.

The RT3096 Double Capacity carts shall have wheels mounted on four swivel caster rigs and two fixed caster rigs.

The casters shall have a load capacity of not less than 325 pounds each.

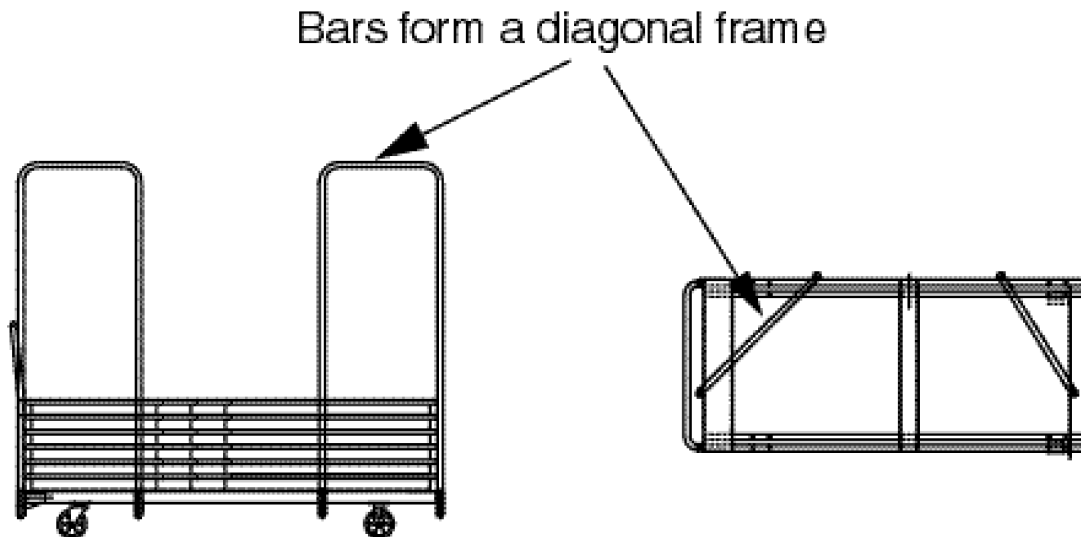

PART NUMBER EXAMPLE: CRT3072DCBLK2

www.mitylite.com 1.800.327.1692 • 1.801.224.0589 • fax 1.801.224.6191