

Sand & Water Sensory Center



Assembly Guide SWT2_2015_A

Check out our other products online at
www.copernicused.com

For assistance, please contact us:

1-800-267-8494

Email info@copernicused.com

Have your packing slip ready for reference

WARNING ! This product is meant to be assembled by an adult.
In its unassembled state, small parts present a hazard.
To be used under direct supervision of an adult.

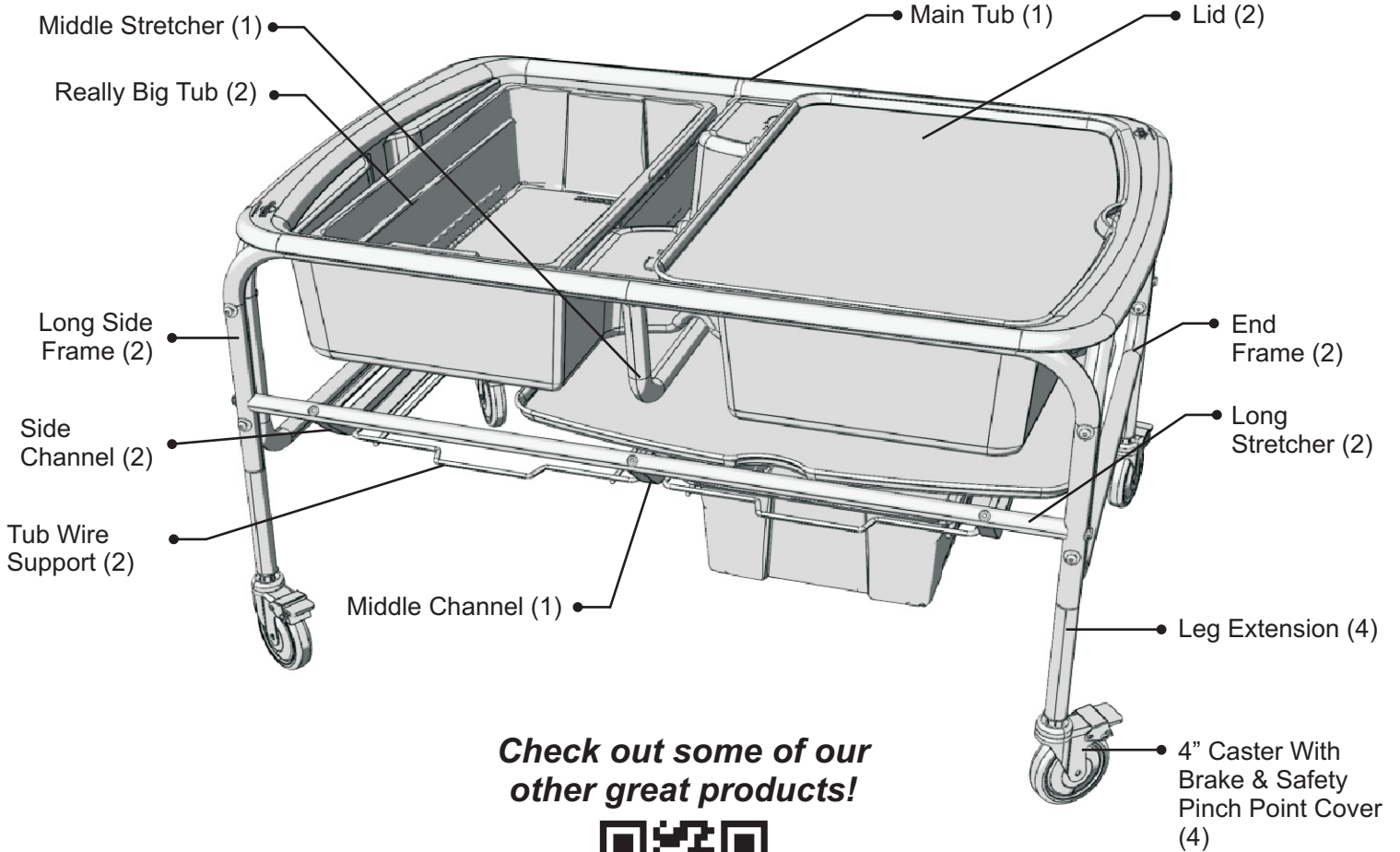

Check out some of our other great products!



www.copernicused.com

Not Shown:
Drain (1)
Drain Plug (1)
Drain Hose (1)
Drain Wrench (1)



Please Recycle

Sand & Water Sensory Center - Parts

Before beginning, you should have:

Additional tools required:



Adjustable wrench

Contents - Box 1

Long Side Frame
2x



Long Stretcher
2x

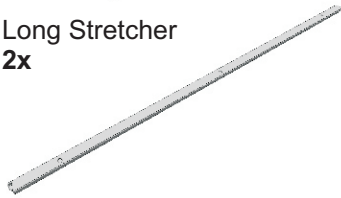

Middle Channel
1x

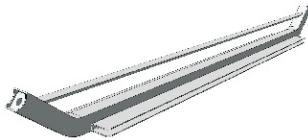

Side Channel
2x

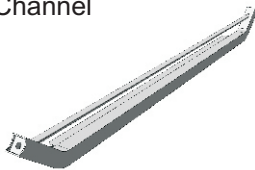

4" Caster With Brake & Safety Pinch Point Cover
4x



Leg Extension
4x

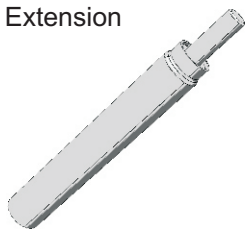

Drain, Drain Plug, Washer
Drain Hose
1x



End Frame
2x

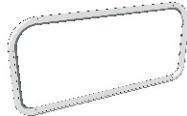

Middle Stretcher
1x

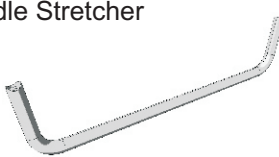

Tub Wire Support
2x



Lid
2x

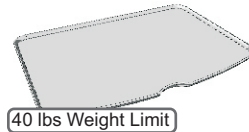

Really Big Tub
2x
(CC4073)

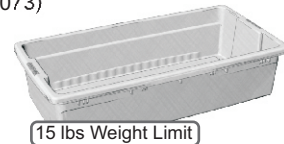

Drain Wrench
1x

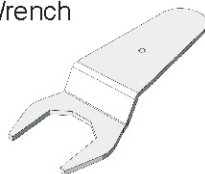

Main Tub
1x

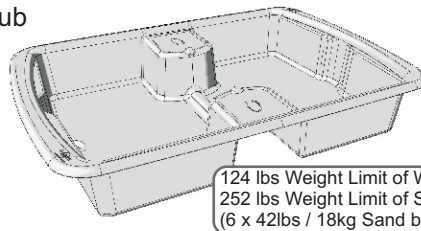

In Box 1

Hardware
Actual Size

(A) M6x35mm Bolt
6x



(B) M6x40mm Bolt
6x



(C) M6x50mm Bolt
8x



(D) M6 Barrel Nut
8x

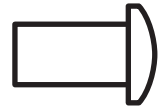

(E) M6 Lock Washer
20x



(G) Contour Washer
20x



(F) M8 Lock Washer
8x



(H) M12 Lock Washer
4x

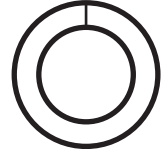

(I) M12 Washer
4x

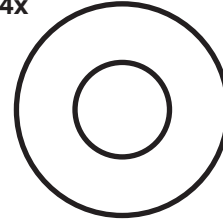

Allen Key
(Not to Scale)
2x

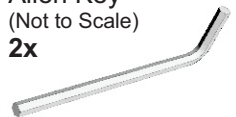

Tips for Assembly - Using this Manual



2 Person

Watch for These Helpful Symbols

- This symbol denotes a 2 Person Task. For safety, please ensure that there are two people working on steps displaying this symbol



- Watch for this symbol throughout the Assembly Instructions. Wherever you see it, pay close attention. The symbol denotes a step needing extra attention to ensure it is done correctly.



- The Star symbol highlights an advisory note

Before You Begin



- Layout and identify all of the included parts
- The hardware has been packed by step
- Read the assembly instructions over once to familiarize yourself with them
- Please note that in its unassembled state, this product contains parts that can be a hazard to small children; it should be assembled by an adult.

As You Assemble the Unit



- Follow the steps in sequence
- Before beginning each step, find the part(s) that you need for that step
- Pay attention to the labeling on the parts, they are there to help direct you at certain stages
- The title of each step states what you will be doing. Review the text and the pictures as you build the unit.

5
YearTub
Warranty5
YearFrame
Warranty

Validate Your Warranty On-Line

To validate your warranty submit the ON-LINE form at www.copernicused.com



Before you begin,
Pay attention to assembly tips located throughout the assembly guide.

Tip 1) Assemble Front Frame with holes facing same side

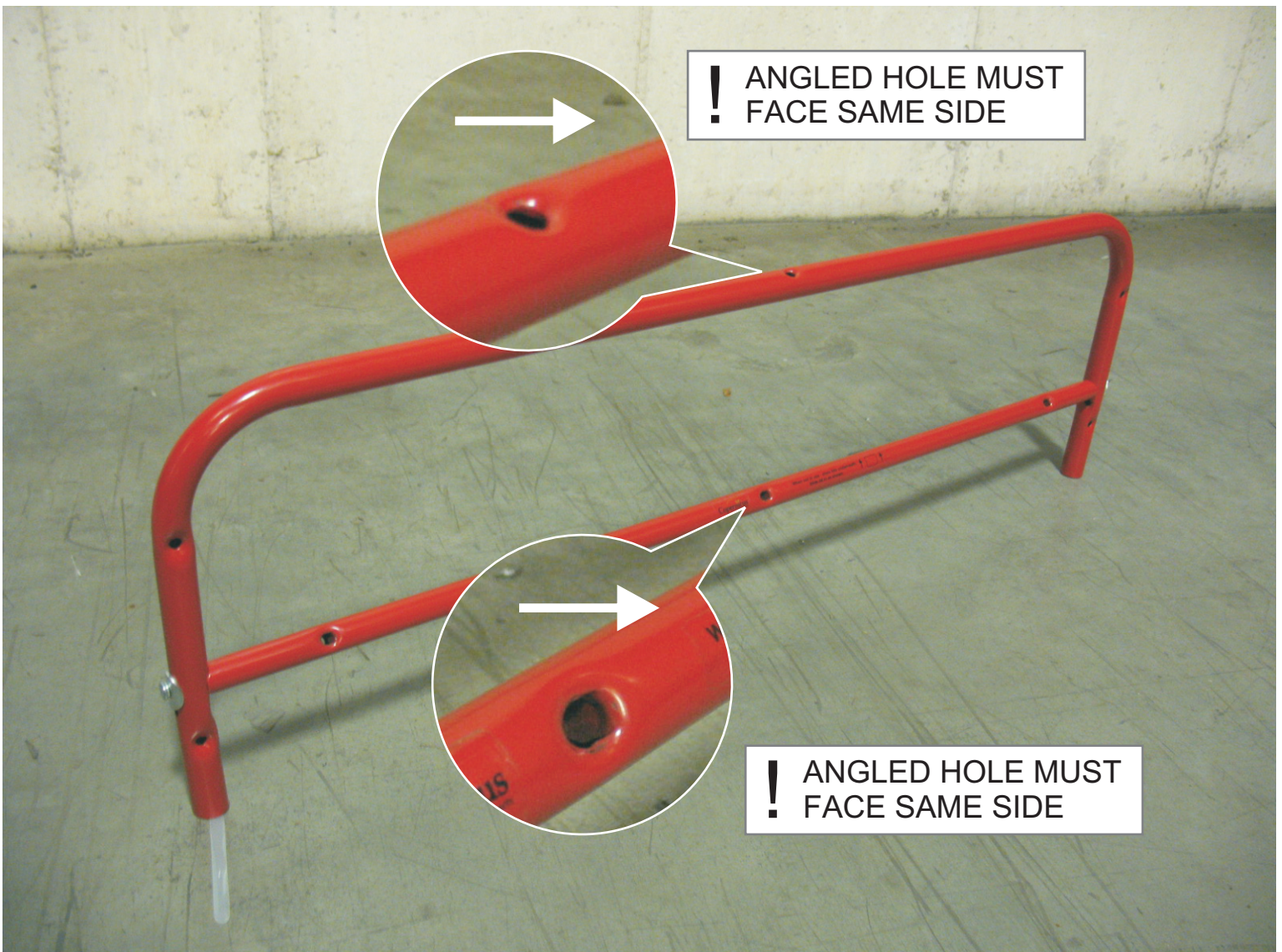

Tips video available here:
<http://copernicused.com/assembly-tips.aspx>

... start assembly on next page

1

Actual Size:



(B) M6x40mm Bolt x 4



(E) M6 Lock Washer x 4



(G) Contour Washer x 4

You will need: (Not to Scale)

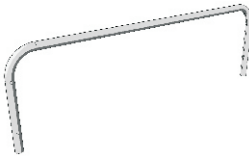

Long Side Frame x 2



Long Stretcher x 2

Assemble Two Front Frames

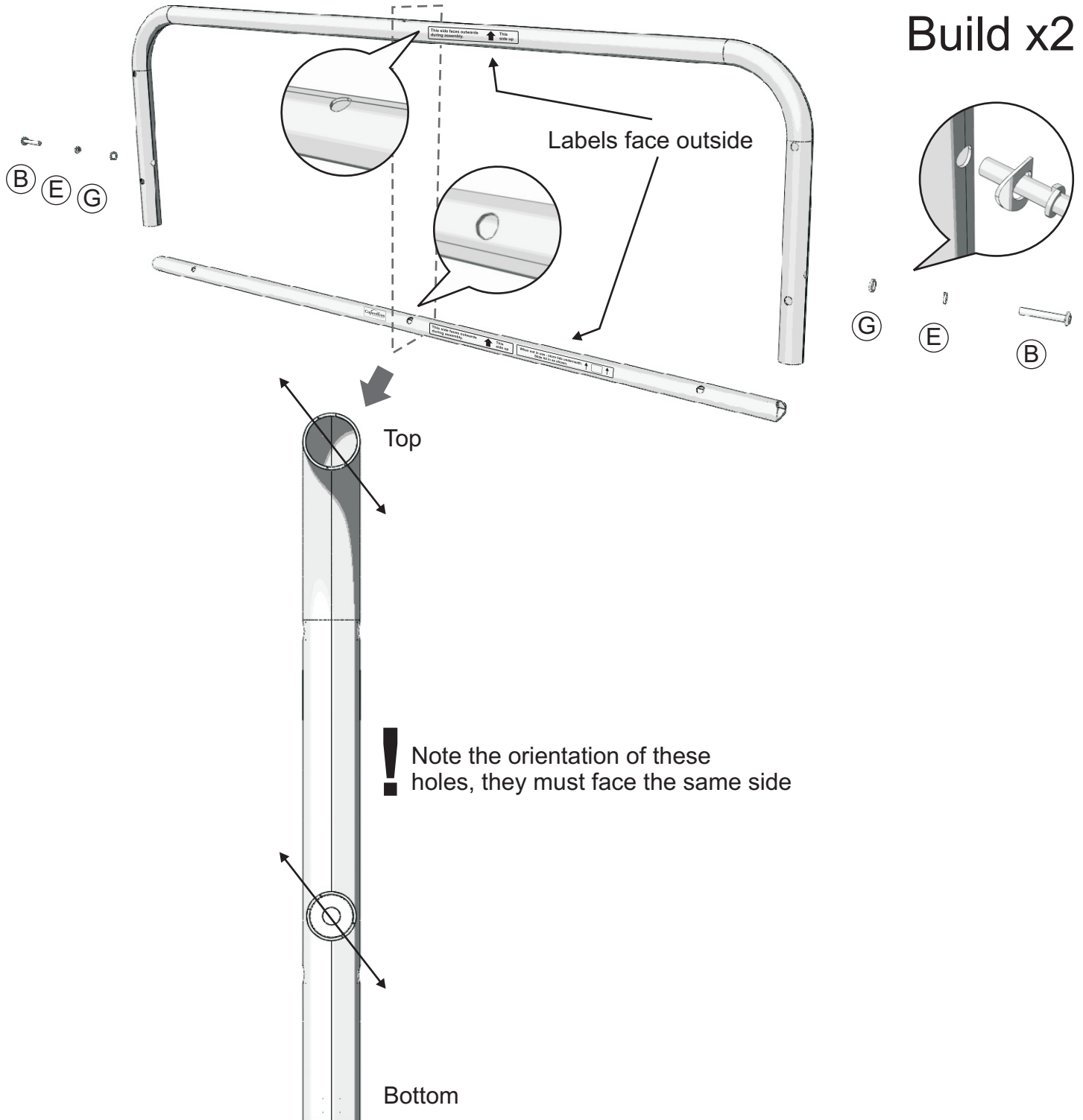

Tip 2) When assembling unit make sure frame holes face outwards on both sides.

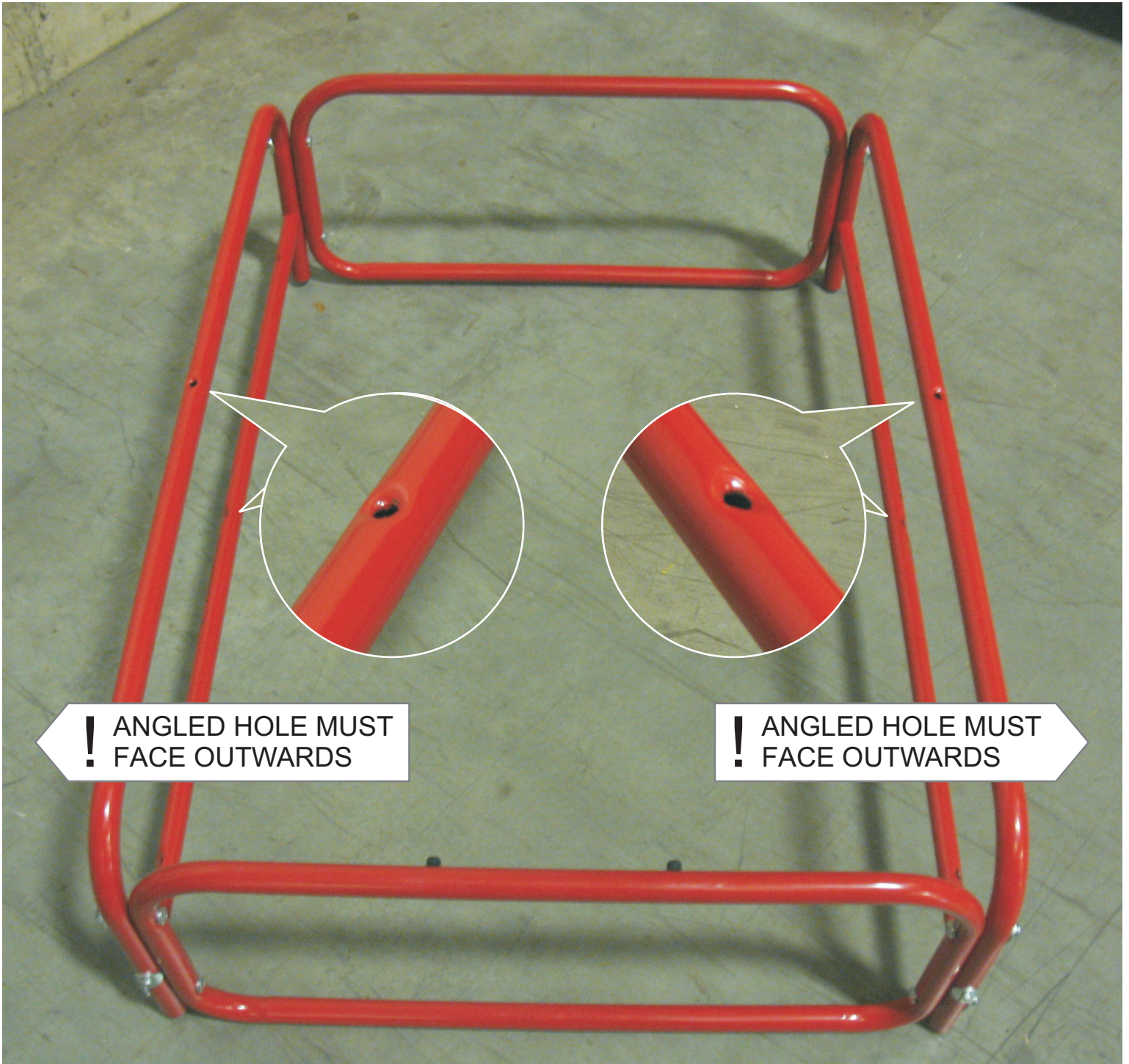

Tips video available here:
<http://copernicused.com/assembly-tips.aspx>

2

Actual Size:



(C) M6x50mm Bolt x8



(E) M6 Lock Washer x 8



(D) M6 Barrel Nut x 8



2 Person

You will need: (Not to Scale)

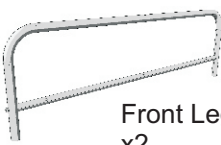

Front Leg Assembly x2

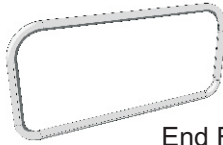

End Frame x2



(F) M8 Lock Washer x 8



(G) Contour Washer x 16

Attach End Frames



Assemble the unit upside down

Do not tighten bolts yet!

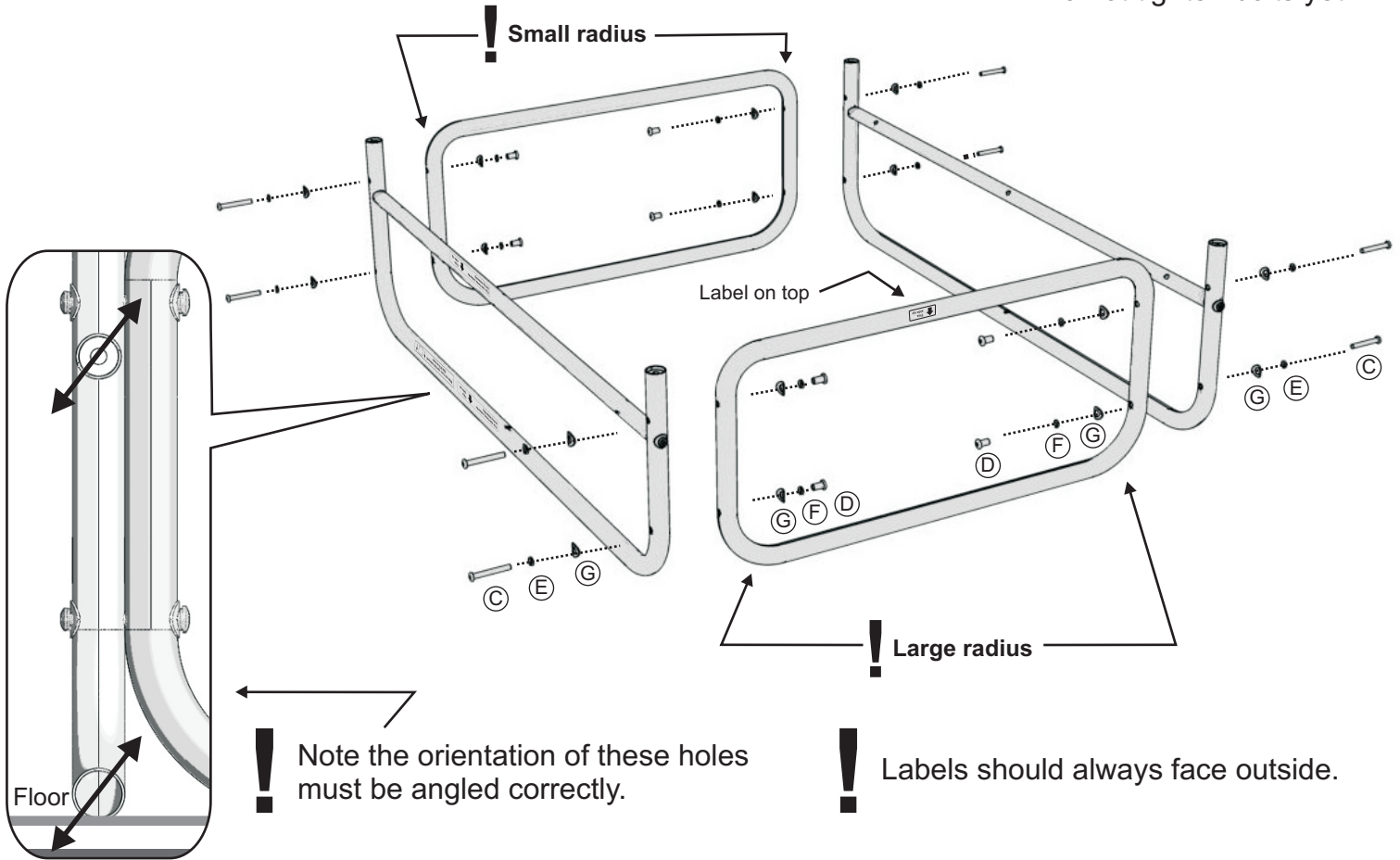

Unit is still flipped upside down.

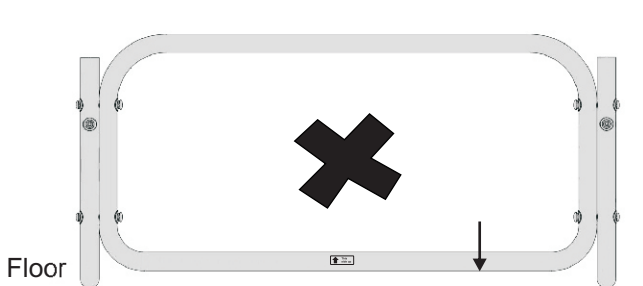

Bars not flush

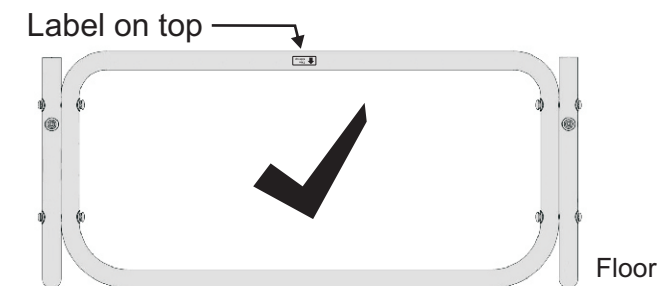

Bars flush on floor



Tip 3)

Assembled frame should look like the following image. Shown with Tub Channels and Middle Stretcher.

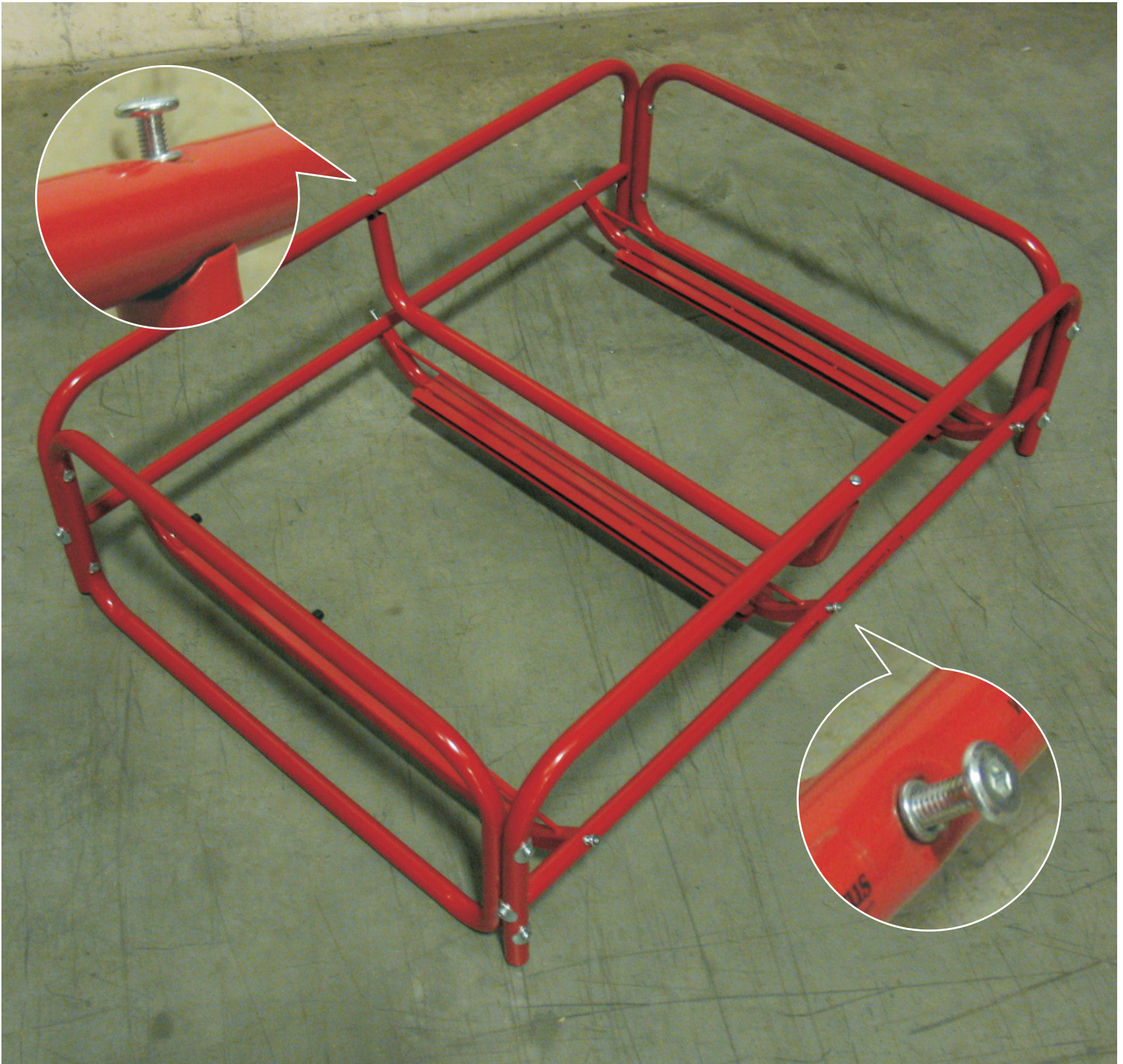

Tips video available here:
<http://copernicused.com/assembly-tips.aspx>

3

Actual Size:



(A) M6x35mm Bolt x 6



(E) M6 Lock Washer x 6



2 Person

You will need: (Not to Scale)

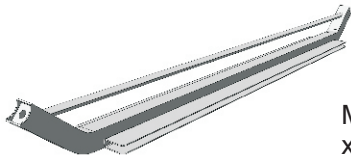

Middle Channel x 1

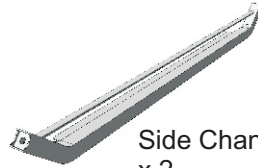

Side Channel x 2

Install Middle and Side Channels

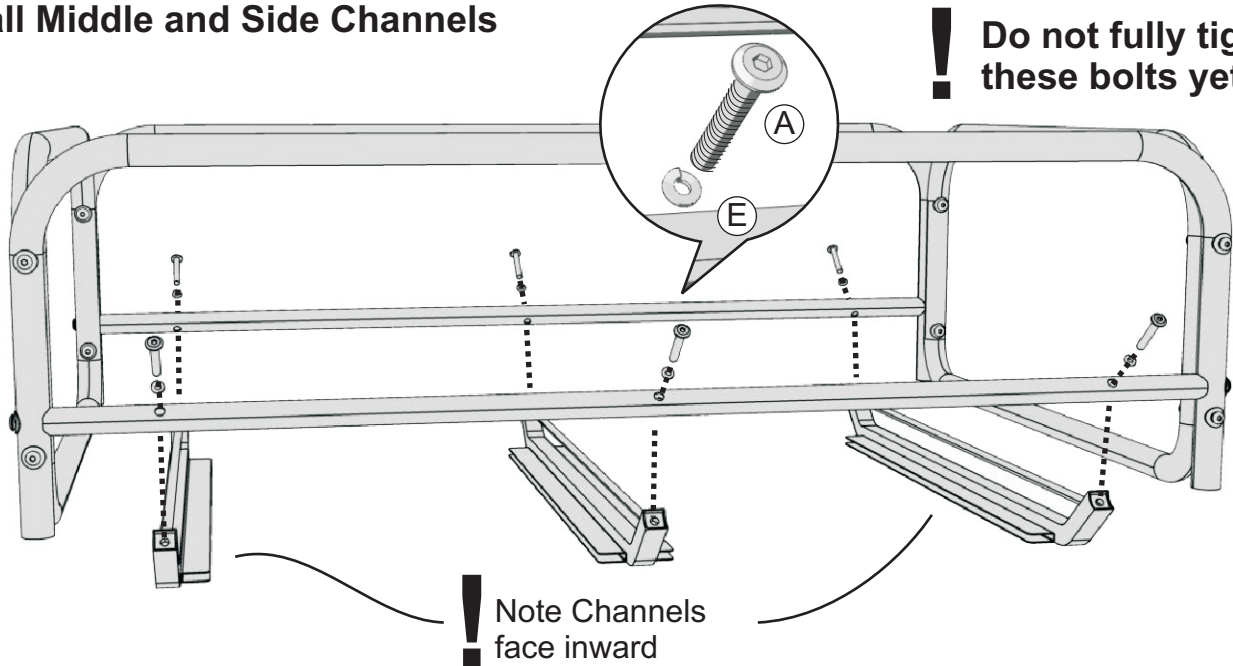

4

Actual Size:



(B) M6x40mm Bolt x 2



(E) M6 Lock Washer x 2



2 Person

You will need: (Not to Scale)

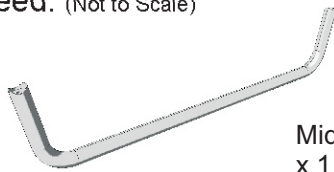

Middle Stretcher x 1

Install Middle Stretcher

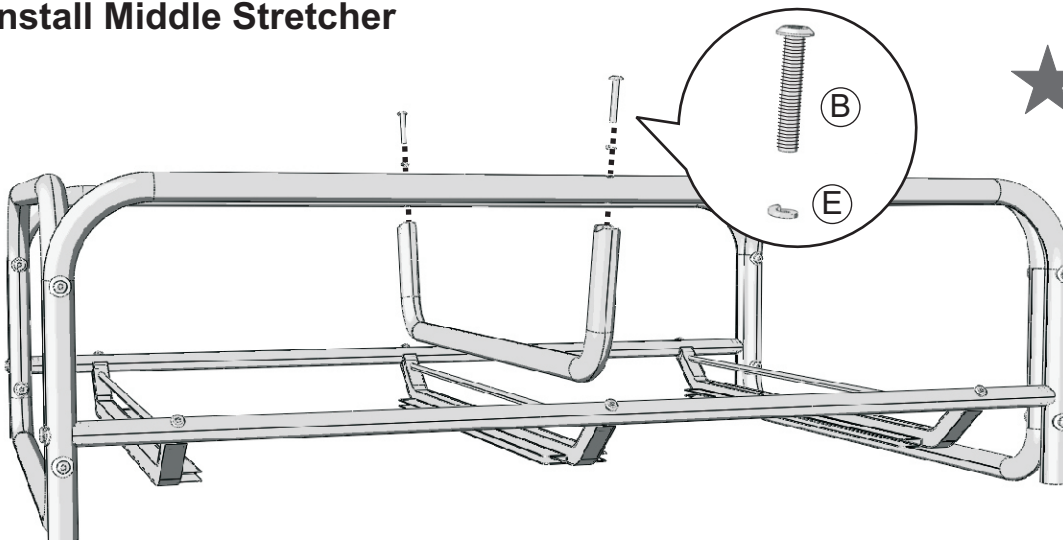

5

Actual Size:

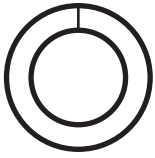

(H) M12 Lock Washer x 4

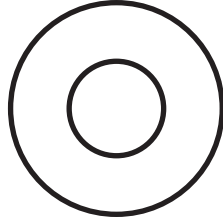

(I) M12 Washer x 4

You will need: (Not to Scale)



4" Caster With Brake & Safety Pinch Point Cover x 4

+ Optional

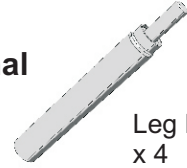

Leg Extension x 4

Determine your desired overall height and install casters

! Remove the nut on the caster if assembling 18" version

18" Tall Sand & Water Sensory Center

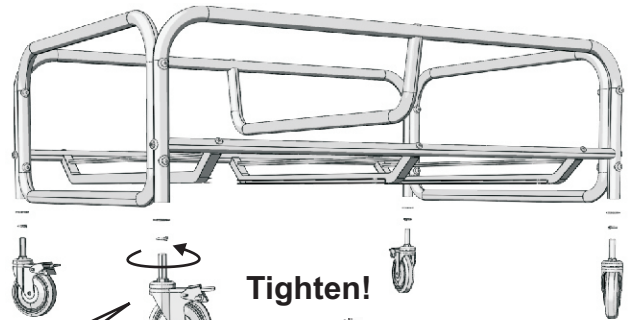
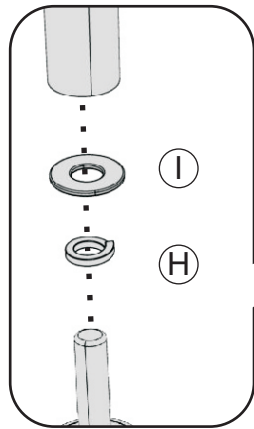
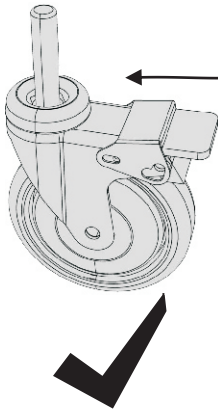
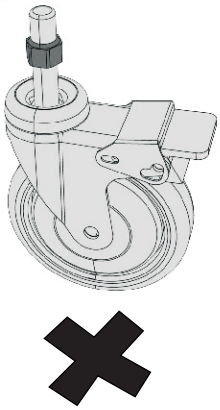

Tighten!

★ Lock casters when installing

OR

! Make sure the nut on the caster is fully threaded before installing the casters on 24" frame.

24" Tall Sand & Water Sensory Center

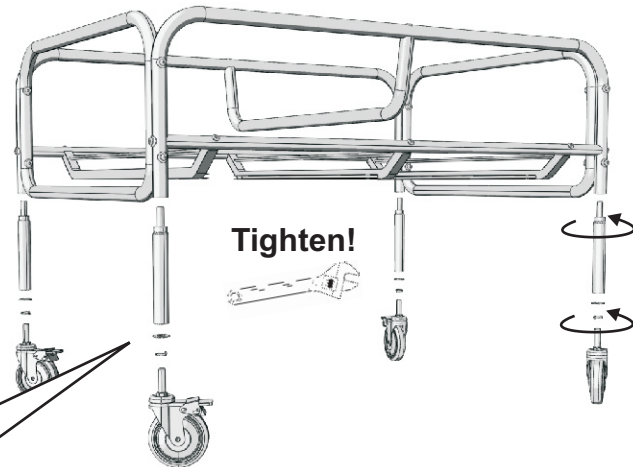
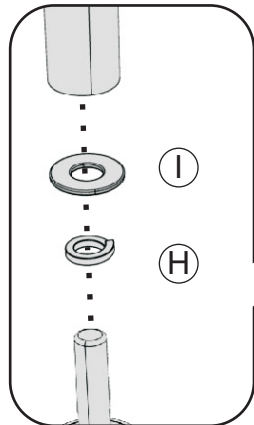
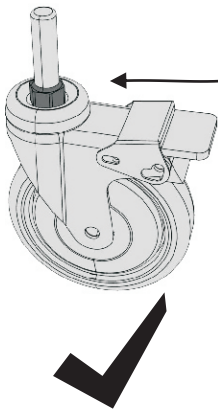
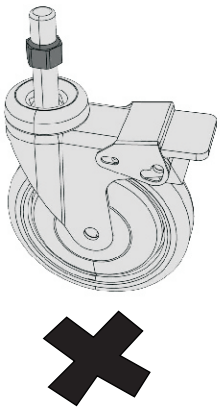

Tighten!

★ Lock casters when installing



6

Actual Size:

You will need: (Not to Scale)

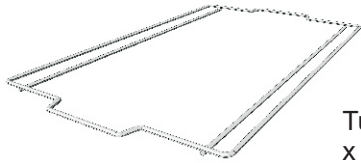

Tub Wire Support
x 2

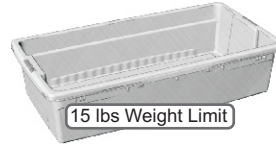

Really Big Tub
x 2

(shown with Leg Extensions installed)

Install Tubs

1

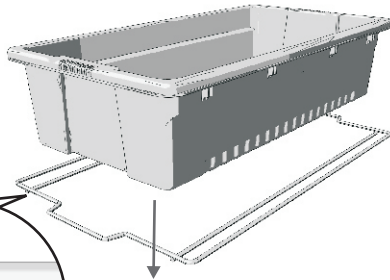

2

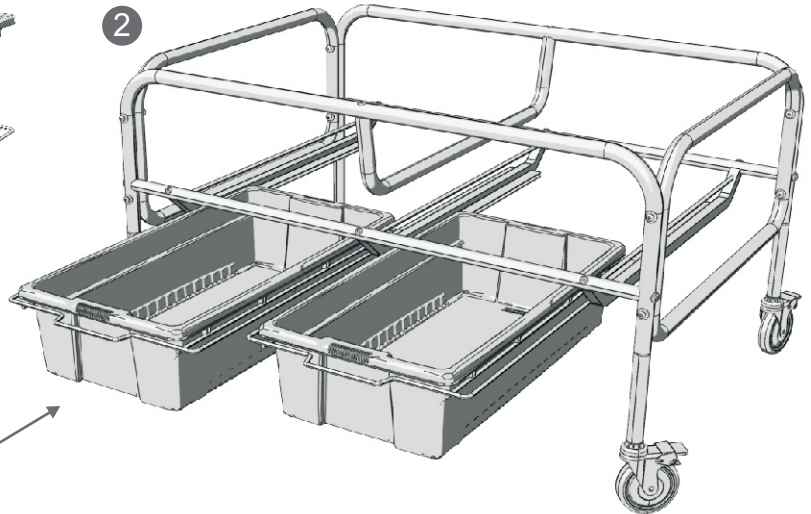

! Note the orientation of the Tub Wire Support

7

Actual Size:

You will need: (Not to Scale)

124 lbs Weight Limit of Water
252 lbs Weight Limit of Sand
(6 x 42lbs / 18kg Sand bags)

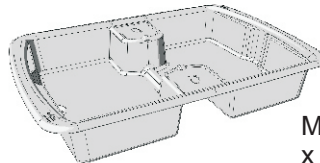

Main Tub
x 1

Verify Rubber Gasket Is Pre-installed on Tub



Make sure rubber gasket is seated in place.

Note because of its shape it is visible from the top & bottom.

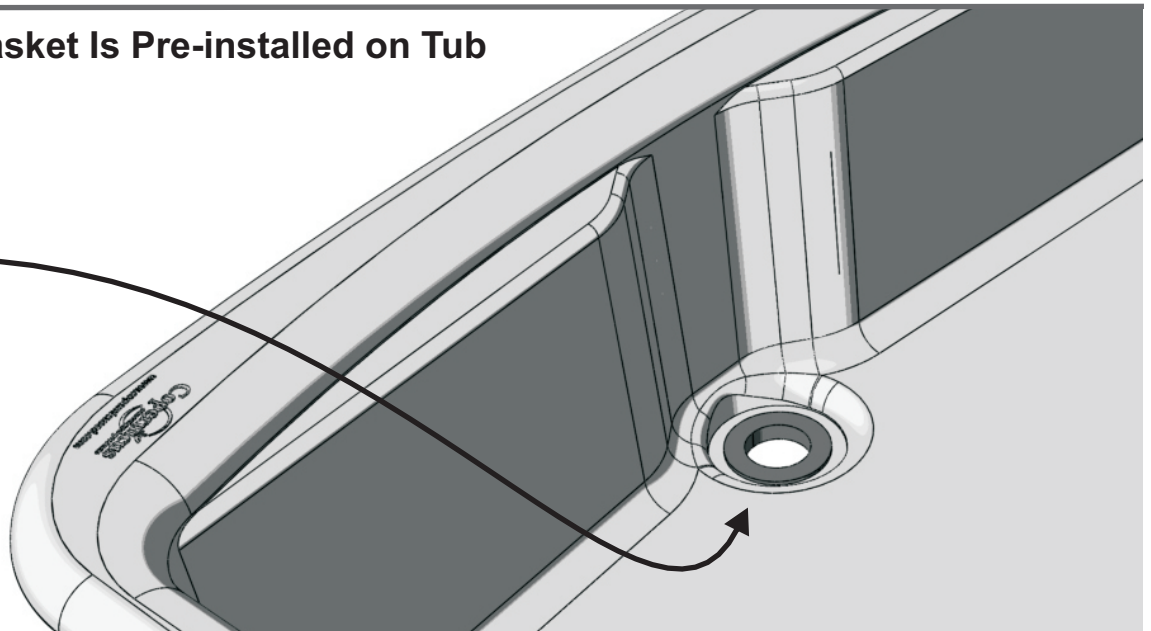

8

You will need: (Not to Scale)

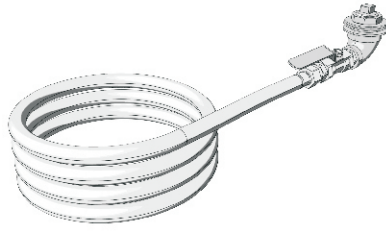

Drain, Drain Plug, Washer
Drain Hose
x 1

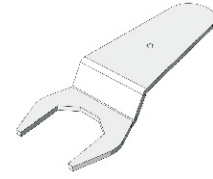

Wrench
x 1

Choose Drain Fittings

! Make sure your hose faces the direction shown below.

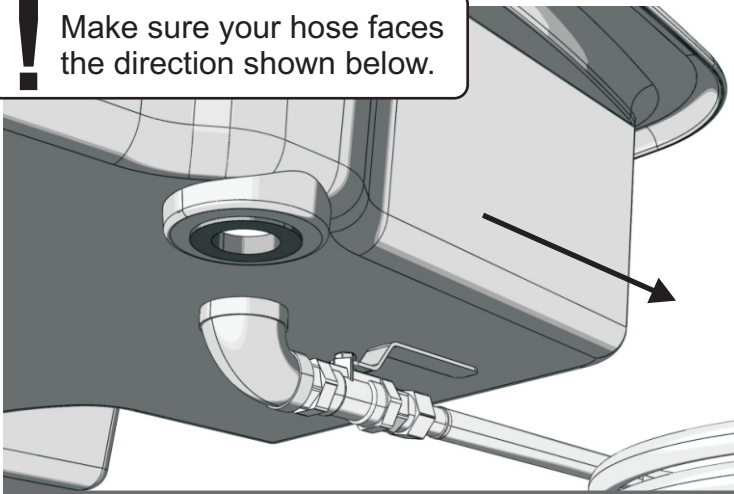

★ Tip: Apply soap to get fitting through washer

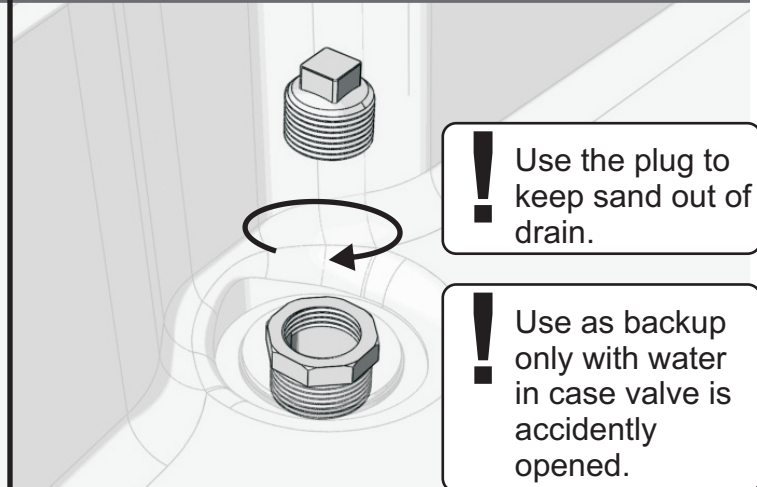
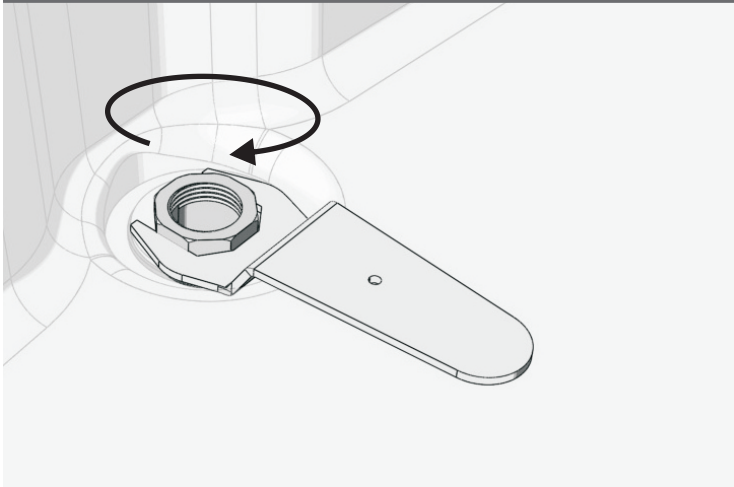
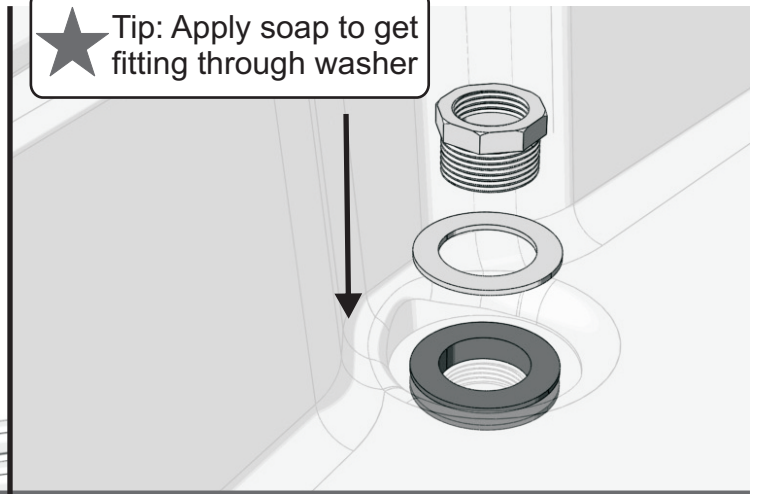

! Use the plug to keep sand out of drain.

! Use as backup only with water in case valve is accidentally opened.

Firmly tighten your fitting !

Tub drops into place for easy assembly

! Note your tub may rock from side to side at first when empty. Filling with sand / water will help it fit better.

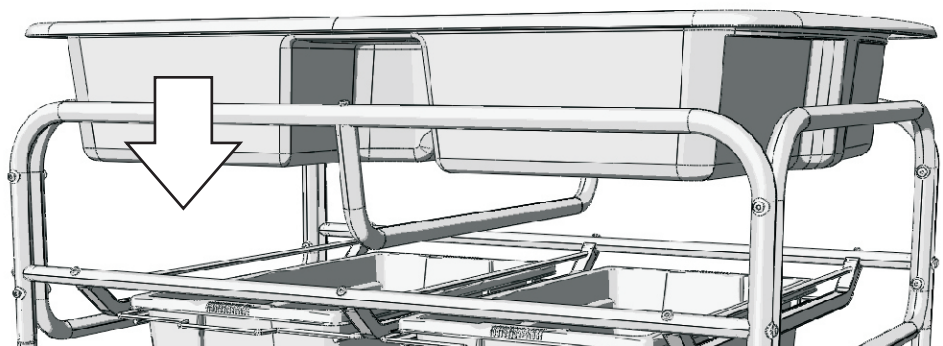

9

Actual Size:

You will need: (Not to Scale)

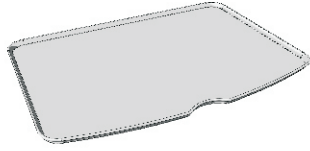

Lid
x 2

Using Your Lids

★ You can use your Lids for activities such as Sand Etching when working with special needs students.

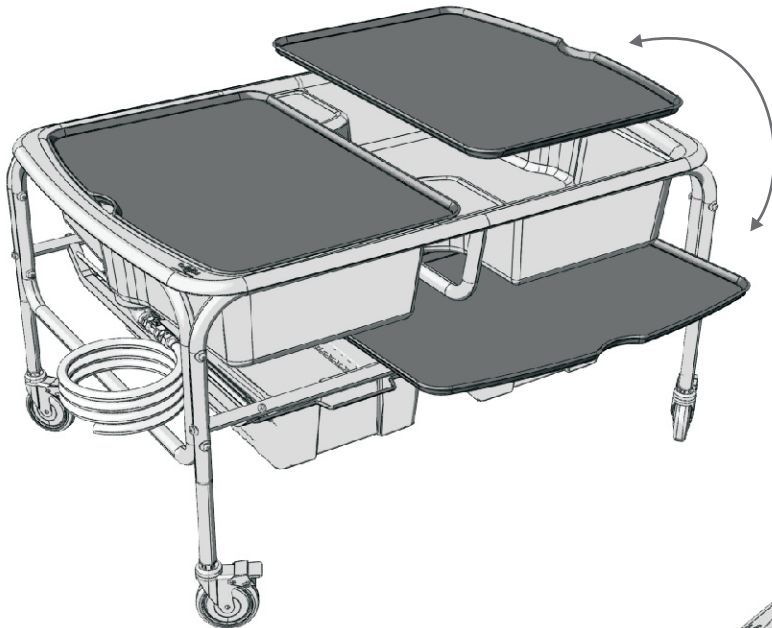
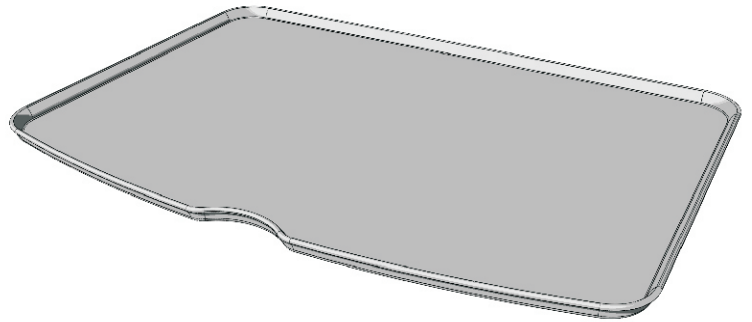

★ You can store your Lids under the Main Tub like shown on the left. Use one lid as a shelf for other activities.

★ You can also use your lids with the Really Big Tubs inside the Main Tub.

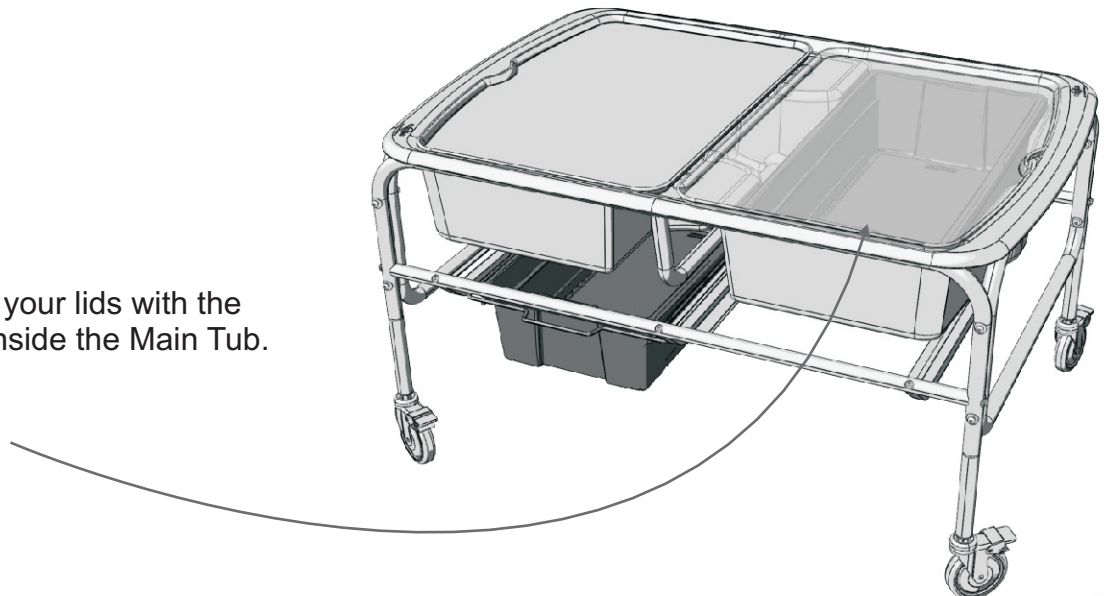

You will need: (Not to Scale)

Tips For Use

★ Use Tubs to store sand & water toys.

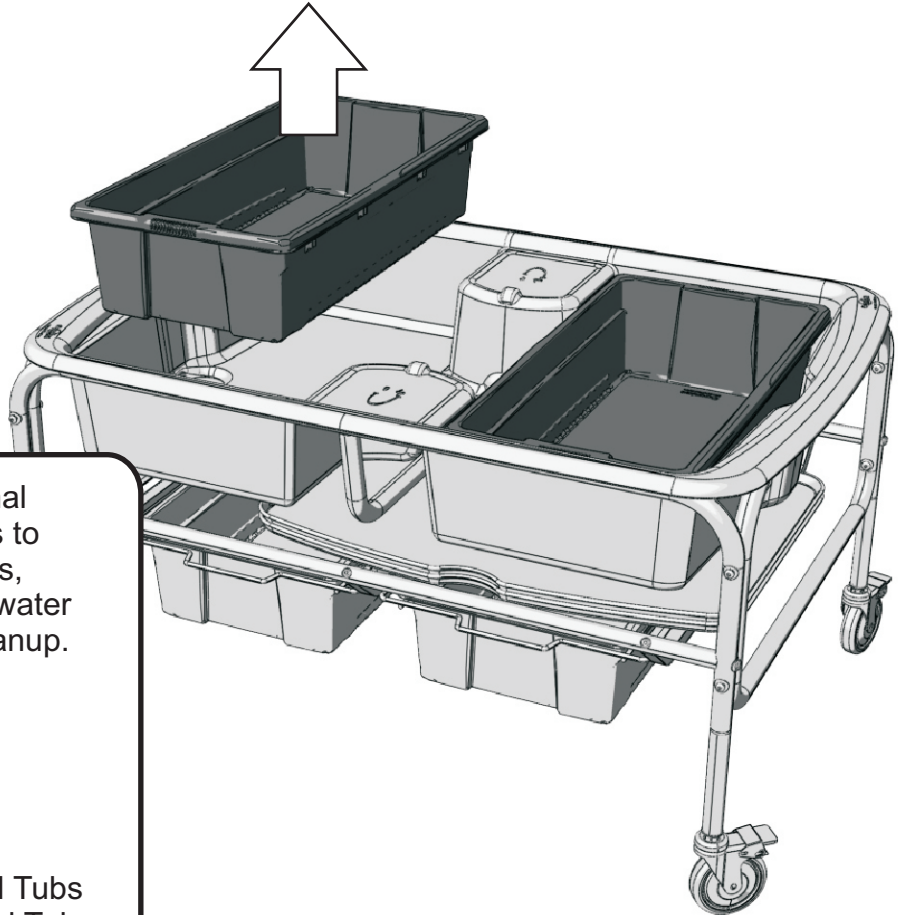

You can purchase additional Copernicus Really Big Tubs to separate different mediums, for example using sand AND water at the same time for easy cleanup.

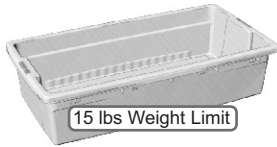

15 lbs Weight Limit

Part Number	Contains:
PTP-20	2 Blue Coloured Tubs
PTP-21	2 Sand Coloured Tubs

★ Use the two landings on the Main Tub as shelves for activities such as weighing with scales.

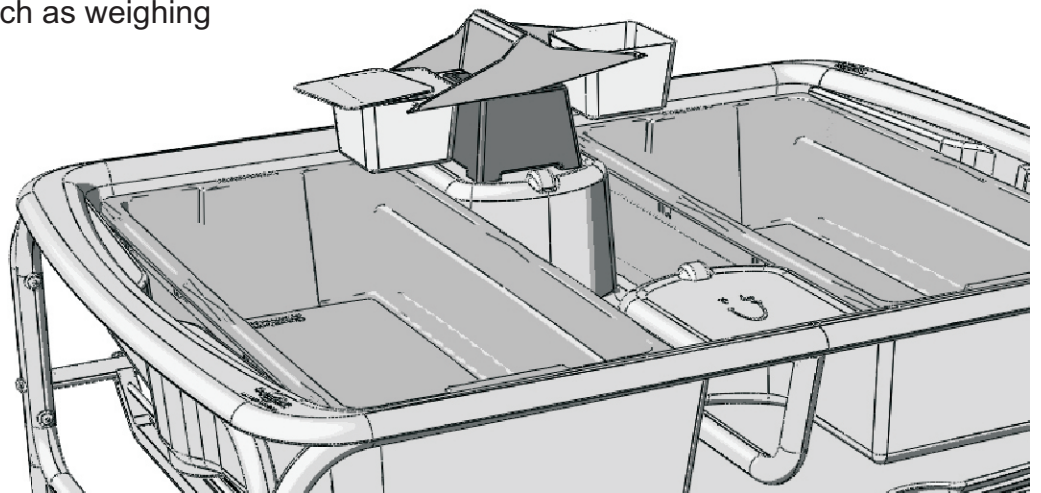

Sand & Water Sensory Center



Assembly Guide SWT2_2015_A

Check out our other products online at
www.copernicused.com

For assistance, please contact us:

1-800-267-8494

Email info@copernicused.com

Have your packing slip ready for reference

Dear Educator,

Thank you for purchasing one of our products.

I hope the assembly of your **Sand & Water Sensory Center** went well.

If you have any questions, or concerns, or ideas for how we can improve, please call us at 1-800-267-8494, where someone will be happy to help.

Enjoy using your new product, and happy teaching,

Jim Phillips
President

Quality schools are the result of quality teachers going above and beyond the call of duty.

VICKI CARUANA

In everyone's life at some time our inner fire goes out. It is then burst into flame by an encounter with another human being. We should all be thankful for those people who rekindle the inner spirit.

ALBERT SCHWEITZER

My idea of education is to unsettle the minds of the young and inflame their intellects.

ROBERT MAYNARD HUTCHINS

Nothing has a better effect upon children than praise.

SIR PHILLIP SIDNEY

