

# Seated Choral Riser Configurations

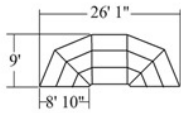
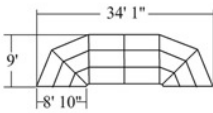
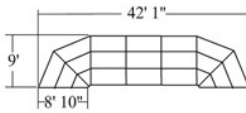
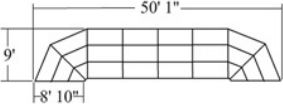
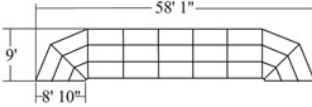
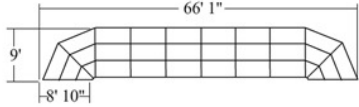
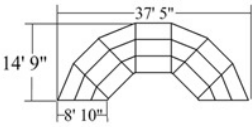
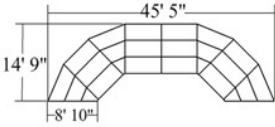
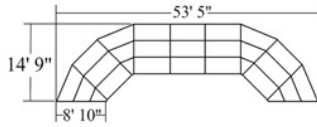
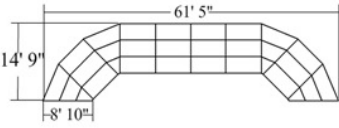
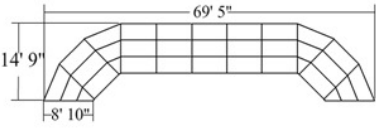
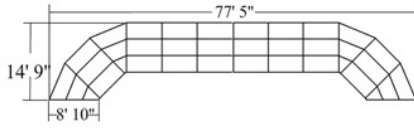

## Bow Set-up

<p>A</p>  <p><b>33-36 Capacity</b></p>	<p>B</p>  <p><b>42-48 Capacity</b></p>	<p>C</p>  <p><b>51-60 Capacity</b></p>
<p>D</p>  <p><b>60-72 Capacity</b></p>	<p>E</p>  <p><b>69-84 Capacity</b></p>	<p>F</p>  <p><b>78-96 Capacity</b></p>

## Ring Set-up

<p>A</p>  <p><b>51-60 Capacity</b></p>	<p>B</p>  <p><b>60-72 Capacity</b></p>	<p>C</p>  <p><b>69-84 Capacity</b></p>
<p>D</p>  <p><b>78-96 Capacity</b></p>	<p>E</p>  <p><b>87-108 Capacity</b></p>	<p>F</p>  <p><b>96-120 Capacity</b></p>

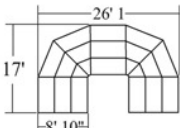
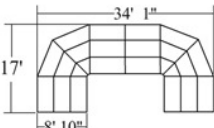
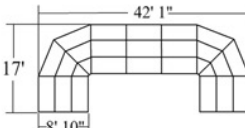
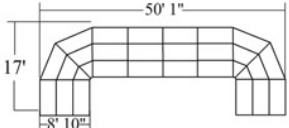
## Oval Set-up

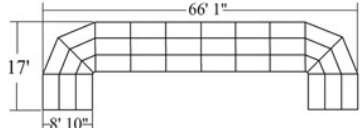
<p>A</p>  <p><b>51-60 Capacity</b></p>	<p>B</p>  <p><b>60-72 Capacity</b></p>	<p>C</p>  <p><b>69-84 Capacity</b></p>
<p>D</p>  <p><b>78-96 Capacity</b></p>	<p>E</p>  <p><b>87-108 Capacity</b></p>	<p>F</p>  <p><b>96-120 Capacity</b></p>

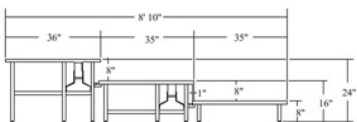

Elevation using 36" Risers

Capacity may vary depending on space between chairs.