

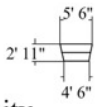



Standing Choral Risers

Tapered Configuration

Using Model RT2L

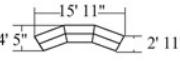
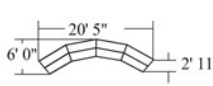
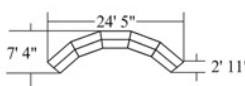
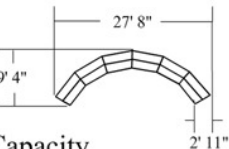
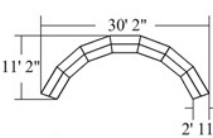
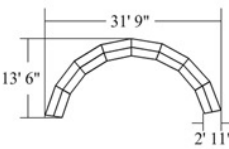
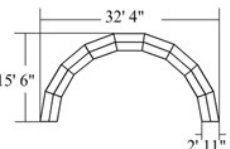
<p>A</p>  <p>9-11 Capacity</p>	<p>B</p>  <p>18-22 Capacity</p>	<p>C</p>  <p>27-33 Capacity</p>
<p>D</p>  <p>36-44 Capacity</p>	<p>E</p>  <p>45-55 Capacity</p>	<p>F</p>  <p>54-66 Capacity</p>
<p>G</p>  <p>63-77 Capacity</p>	<p>H</p>  <p>72-88 Capacity</p>	<p>I</p>  <p>81-99 Capacity</p>

Using Model RT3L

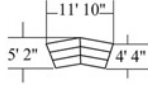
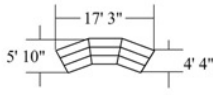
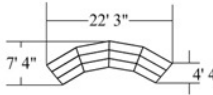
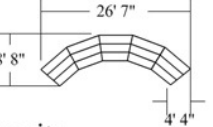
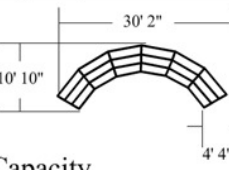
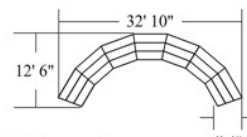
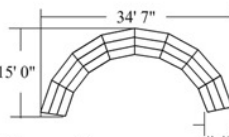
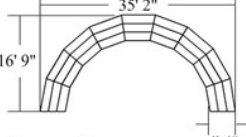
<p>A</p>  <p>13-16 Capacity</p>	<p>B</p>  <p>26-32 Capacity</p>	<p>C</p>  <p>39-48 Capacity</p>
<p>D</p>  <p>52-64 Capacity</p>	<p>E</p>  <p>65-80 Capacity</p>	<p>F</p>  <p>78-96 Capacity</p>
<p>G</p>  <p>91-112 Capacity</p>	<p>H</p>  <p>104-128 Capacity</p>	<p>I</p>  <p>117-144 Capacity</p>

Using Model RT4L

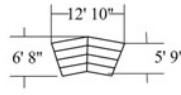
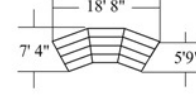
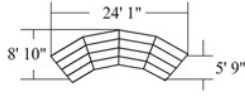
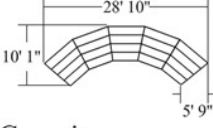
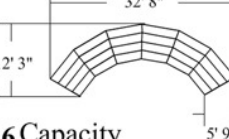
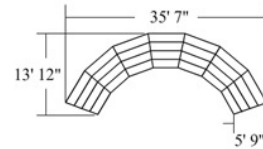
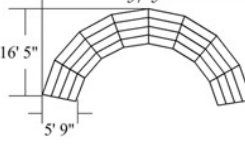
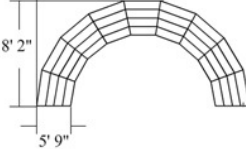
<p>A</p>  <p>18-21 Capacity</p>	<p>B</p>  <p>36-42 Capacity</p>	<p>C</p>  <p>54-63 Capacity</p>
<p>D</p>  <p>72-84 Capacity</p>	<p>E</p>  <p>90-105 Capacity</p>	<p>F</p>  <p>108-126 Capacity</p>
<p>G</p>  <p>126-147 Capacity</p>	<p>H</p>  <p>144-168 Capacity</p>	<p>I</p>  <p>162-189 Capacity</p>

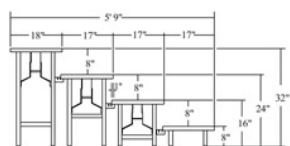

Elevation

Capacities include one row of singers standing at floor level. Actual capacities may vary based on how singers are positioned.