

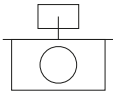

Applications

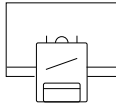

Offices



Classrooms



Retail



Home



Large surfaces











Hotels









Restaurants

Specifications (Series luminaires)



	Voltage (V)	230V
Hz	Frecuency (Hz)	50-60Hz
	Dimming	No
	IP Tightness index	IP20
	Body color	White
	Body	AL
K	Colour temperature	3.000K/3.000K
	CRI Colour rendering index	>80
	Optical	PC
	Opening angle	90°
	UGR	<19

	Measures	1.195x295x14,5mm
	Mounting position	Empotrar
	Operating temperature	-5°C~+35 °C
	Flux (lm)	3.725/4.164lm
	Electrical isolation	CII
	Lifetime	(L70B50>) 50.000h



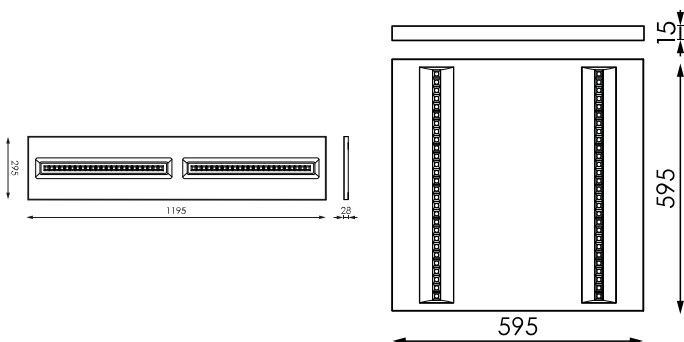

Prilux guarantees a $\pm 10\%$ tolerance in light flux measurements.

Dimensions





References



	W _{LED}	W		ϕ _{LED}	ϕ _{LUM}	K		
496360	35W	32W	850mA	4.678/4.986lm	3.725/4.164lm	3.000K,4.000K	575 x 575	No
496377	35W	32W	850mA	4.678/4.986lm	3.725/4.164lm	3.000K,4.000K	1.175 x 275	No

Accessories



		
<p>207591</p> <p>FRAME BL RECESS PLASTER SILENT LED 120X30CM</p>	<p>207874</p> <p>WH SURFACE DRAWER SILENT LED 120X30CM</p>	<p>491532</p> <p>DIANE TECH SUSPENSION KIT 1,5M</p>



Solutions

S



CTE Pack

description

Regulation for the contribution of natural light to comply with the requirements of the CTE. Independent control of two lines of dimmable DALI luminaires with sensor to install in a luminaire or surface box. Preconfigured for easy operation.



CLASSROOMS Pack

description

Regulation by contribution of natural light and stand alone presence. Lighting control system to meet CTE requirements and optimize energy use by taking advantage of natural light and automatic shutdown in case of absence.



BLUETOOTH Pack

description

Device that enables DALI luminaire control through any Bluetooth® terminal via free APP that offers us control of flow regulation, color, scene configuration, behavior linked to schedules.

Info

For more information on the different solutions compatible with this luminaire, consult the following BIDI codes or on the web www.prilux.es