

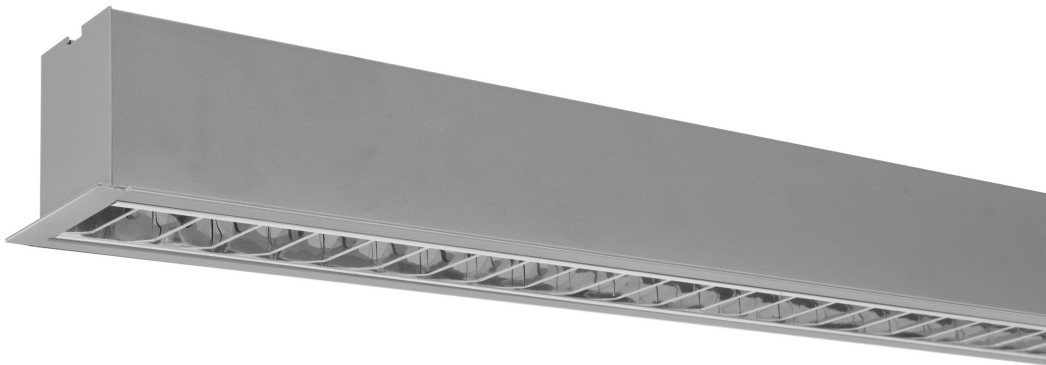

MADE IN SPAIN  
Design by PRILUX

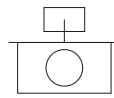

## Applications



Offices

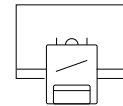

Classrooms



Retail



Home



Large surfaces



Hotels











Restaurants







Health care



## Specifications (Series luminaires)

	<b>Voltage (V)</b>	220-240V
Hz	<b>Frecuency (Hz)</b>	50-60Hz
	<b>Current (A)</b>	max.390mA
$\phi$	<b>Power factor (Cos fi)</b>	Hasta 0,93
	<b>LED number</b>	72/90
	<b>Dimming</b>	No
	<b>IP Tightness index</b>	IP20
	<b>Body color</b>	9006
	<b>Diffuser Material</b>	AL-SP
	<b>Body</b>	AL
K	<b>Colour temperature</b>	4.000K/4.000K
	<b>CRI Colour rendering index</b>	>80

	<b>Measures</b>	1.154x80x80mm
	<b>Mounting position</b>	Empotrar
$\phi_{LUM}$	<b>Flux (lm)</b>	2.286lm
	<b>Electrical isolation</b>	CI
	<b>Lifetime</b>	L70>50.000h

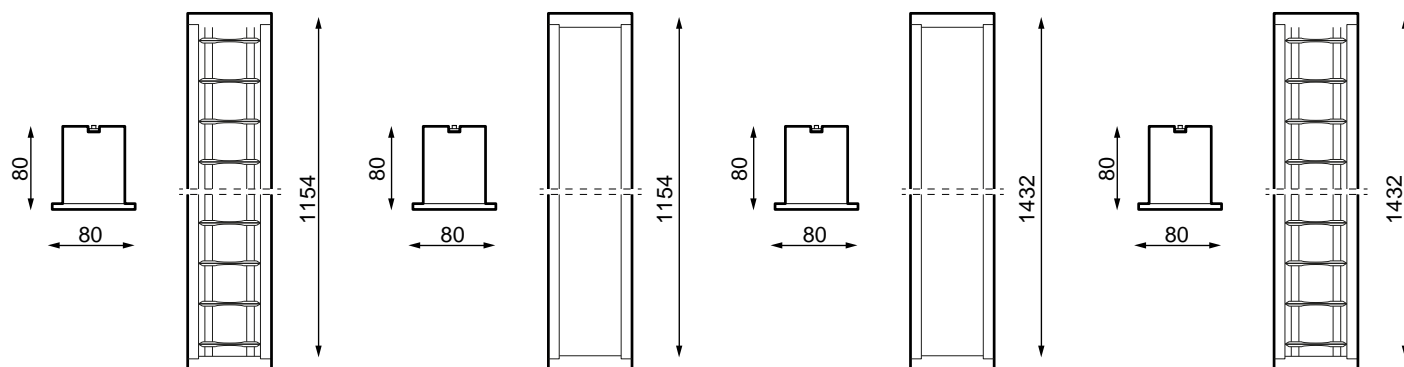

Prilux guarantees a  $\pm 10\%$  tolerance in light flux measurements.

## Dimensions



## References



	$W_{LED}$	W		$\phi_{LED}$	$\phi_{LUM}$	K	
<b>490399</b>	30W	32W	390mA	3.945lm	2.286lm	4.000K	1.154x80x80mm
<b>490405</b>	30W	32W	390mA	3.945lm	2.400lm	4.000K	1.154x80x80mm
<b>490412</b>	37W	40W	390mA	4.930lm	2.857lm	4.000K	1.432x80x80mm
<b>490429</b>	37W	40W	390mA	4.930lm	3.000lm	4.000K	1.432x80x80mm

## Photometry

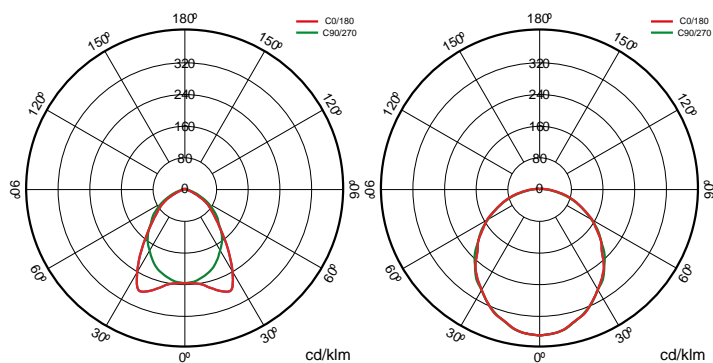

## On request



Presence and brightness sensor (mod.  
1x/2x 1.200mm/1.500mm)



Dali

Bluetooth

K

WAS(\*Not compatible for 37W luminaires)

>80 3.000K

>80 4.000K

>80 4.000K



Available RAL colors (Consult)



## Solutions

S



### CTE Pack

#### description



Regulation for the contribution of natural light to comply with the requirements of the CTE. Independent control of two lines of dimmable DALI luminaires with sensor to install in a luminaire or surface box. Preconfigured for easy operation.



### Was Indoor

#### description



The WAS INDOOR solution is specifically aimed at increasing the well-being of users in places such as hospitals, nursing homes, wellness centres, classrooms and offices. The circadian lighting is applied in workplaces to improve visual conditions, comfort and the workers' performance, resulting in a higher productivity and a better development of the company.



### Bluetooth package

#### description



Casambi version of our fixtures that enables through any Bluetooth® terminal via free APP that offers the control of flow regulation, color, scene configuration, behavior linked to schedules. Multiple accessories can be configured to work on the same network to unify the control of one or more spaces, being able to create groups, scenes and dynamic sequences to measure. The Bluetooth® device is valid for any DALI luminaire.

#### Info



For more information on the different solutions compatible with this luminaire, consult the following BIDI codes or on the web [www.prilux.es](http://www.prilux.es)



**Info**



You need DALI drive