

HYDRAULIC MOTORS HP

APPLICATION

- » Conveyors
- » Feeding mechanism of robots and manipulators
- » Metal working machines
- » Textile machines
- » Agricultural machines
- » Food industries
- » Grass cutting machinery etc.

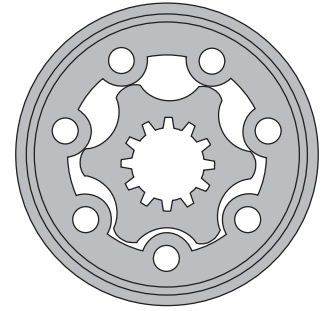

CONTENTS

| | |
|---------------------------------------|-------|
| Specification data | 54+55 |
| Dimensions and mounting | 56+57 |
| Shaft versions | 58+59 |
| Permissible shaft loads..... | 60 |
| Permissible shaft seal pressure | 60 |
| Order code | 61 |

OPTIONS

- » Model - Spool valve, gerotor
- » Flange mount
- » Side ports
- » Shafts - straight, splined and tapered
- » SAE and manifold ports
- » Speed sensing
- » Other special features

GENERAL

| | |
|---|--|
| Max. Displacement, in ³ /rev [cm ³ /rev] | 24.16 [396] |
| Max. Speed, [RPM] | 1408 |
| Max. Torque, lb-in [daNm] | cont. 3665 [41,4] int. 4520 [51,1] |
| Max. Output, HP [kW] | 16.1 [12] |
| Max. Pressure Drop, PSI [bar] | cont. 1815 [125] int. 2540 [175] |
| Max. Oil Flow, GPM [lpm] | 19.8 [75] |
| Min. Speed, [RPM] | 10 |
| Pressure fluid | Mineral based- HLP(DIN 51524) or HM(ISO 6743/4) |
| Temperature range, °F [°C] | -40+284 [-40+140] |
| Optimal Viscosity range, SUS [mm²/s] | 98+347 [20+75] |
| Filtration | ISO code 20/16 (Min. recommended fluid filtration of 25 microns) |

Oil flow in drain line

| Pressure drop PSI [bar] | Viscosity SUS [mm ² /s] | Oil flow in drain line GPM [lpm] |
|----------------------------|---------------------------------------|--|
| 1450 [100] | 98 [20] | .660 [2,5] |
| | 164 [35] | .476 [1,8] |
| 2030 [140] | 98 [20] | .925 [3,5] |
| | 164 [35] | .740 [2,8] |

Pressure Losses

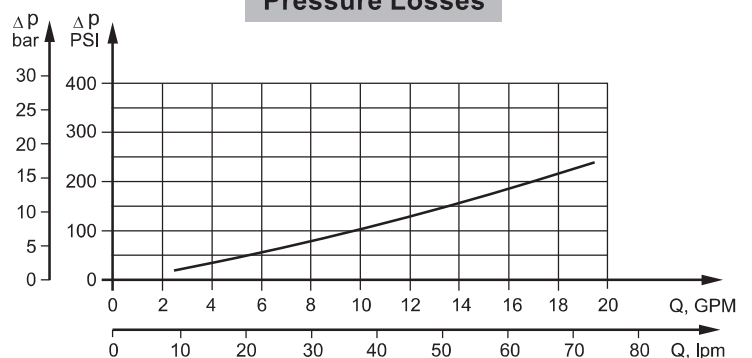

SPECIFICATION DATA

| Type | | HP 25 | HP 32 | HP 40 | HP 50 | HP 80 | HP 100 |
|--|--------------------------|-------------|-------------|-------------|-------------|-------------|-------------|
| Displacement, in³/rev [cm³/rev] | | 1.73 [28,4] | 2.11 [34,5] | 2.47 [40,5] | 3.02 [49,5] | 4.83 [79,2] | 6.04 [99,0] |
| Max. Speed, [RPM] | Cont. | 1055 | 1160 | 900 | 909 | 758 | 606 |
| | Int.* | 1600 | 1300 | 1110 | 1111 | 947 | 758 |
| Max. Torque lb-in [daNm] | Cont. | 290 [3,3] | 460 [5,2] | 575 [6,5] | 717 [8,1] | 1141 [12,9] | 1434 [16,2] |
| | Int.* | 400 [4,5] | 620 [7,0] | 795 [9,0] | 990 [11,2] | 1585 [17,9] | 1974 [22,3] |
| | Peak** | 610 [6,9] | 780 [8,8] | 975 [11] | 1210 [13,7] | 1930 [21,8] | 2420 [27,3] |
| Max. Output HP [kW] | Cont. | 4.60 [3,4] | 7.5 [5,6] | 7.5 [5,6] | 11.3 [8,4] | 11.3 [8,4] | 11.3 [8,4] |
| | Int.* | 8.2 [6,1] | 11.3 [8,4] | 11.5 [8,6] | 14.1 [10,5] | 16 [12] | 16 [12] |
| Max. Pressure Drop PSI [bar] | Cont. | 1450 [100] | 1815 [125] | 1815 [125] | 1815 [125] | 1815 [125] | 1815 [125] |
| | Int.* | 2030 [140] | 2465 [170] | 2540 [175] | 2540 [175] | 2540 [175] | 2540 [175] |
| | Peak** | 3260 [225] | 3260 [225] | 3260 [225] | 3260 [225] | 3260 [225] | 3260 [225] |
| Max. Oil Flow GPM [lpm] | Cont. | 8 [30] | 10.5 [40] | 10.5 [40] | 11.9 [45] | 15.9 [60] | 15.9 [60] |
| | Int.* | 10.5 [40] | 11.9 [45] | 11.9 [45] | 14.5 [55] | 19.8 [75] | 19.8 [75] |
| Max. Inlet Pressure PSI [bar] | Cont. | 2030 [140] | 2030 [140] | 2030 [140] | 2030 [140] | 2030 [140] | 2030 [140] |
| | Int.* | 2540 [175] | 2540 [175] | 2540 [175] | 2540 [175] | 2540 [175] | 2540 [175] |
| | Peak** | 3260 [225] | 3260 [225] | 3260 [225] | 3260 [225] | 3260 [225] | 3260 [225] |
| Max. Return Pressure with Drain Line PSI [bar] | Cont. | 2030 [140] | 2030 [140] | 2030 [140] | 2030 [140] | 2030 [140] | 2030 [140] |
| | Int.* | 2540 [175] | 2540 [175] | 2540 [175] | 2540 [175] | 2540 [175] | 2540 [175] |
| | Peak** | 3260 [225] | 3260 [225] | 3260 [225] | 3260 [225] | 3260 [225] | 3260 [225] |
| Max. Starting Pressure with Unloaded Shaft, PSI [bar] | | 145 [10] | 145 [10] | 145 [10] | 145 [10] | 145 [10] | 145 [10] |
| Min. Starting Torque lb-in [daNm] | At max.press. drop Cont. | 265 [3,0] | 425 [4,8] | 566 [6,4] | 655 [7,4] | 1045 [11,8] | 1300 [14,7] |
| | At max.press. drop Int.* | 362 [4,1] | 565 [6,4] | 725 [8,2] | 900 [10,2] | 1440 [16,3] | 1800 [20,3] |
| Min. Speed***, [RPM] | | 20 | 15 | 10 | 10 | 10 | 10 |
| Weight, lb [kg] | HP | 11.5 [5,2] | 11.5 [5,2] | 11.5 [5,2] | 11.7 [5,3] | 11.9 [5,4] | 12.3 [5,6] |
| | HPQ | 10.6 [4,8] | 10.6 [4,8] | 10.6 [4,8] | 10.8 [4,9] | 11.25 [5,1] | 11.69 [5,3] |

* Intermittent operation: the permissible values may occur for max. 10% of every minute.

** Peak load: the permissible values may occur for max. 1% of every minute.

*** For speeds lower than given, consult factory or your regional manager.

- Intermittent speed and intermittent pressure drop must not occur simultaneously.
- Recommended filtration is per ISO cleanliness code 20/16. A nominal filtration of 25 micron or better.
- Recommend using a premium quality, anti-wear type mineral based hydraulic oil HLP(DIN51524) or HM (ISO 6743/4).
If using synthetic fluids consult the factory for alternative seal materials.
- Recommended minimum oil viscosity 70 SUS [13 mm²/s] at 122°F [50°C].
- Recommended maximum system operating temperature is 180°F [82°C].
- To assure optimum motor life fill with fluid prior to loading and run at moderate load and speed for 10-15 minutes.

SPECIFICATION DATA (continued)

| Type | | HP 125 | HP 160 | HP 200 | HP 250 | HP 315 | HP 400 |
|--|--------------------------|--------------|--------------|-------------|--------------|--------------|-------------|
| Displacement, in³/rev [cm³/rev] | | 7.55 [123,8] | 9.66 [158,4] | 12.1 [198] | 15.1 [247,5] | 19.3 [316,8] | 24.16 [396] |
| Max. Speed, [RPM] | Cont. | 485 | 379 | 303 | 242 | 189 | 152 |
| | Int.* | 606 | 473 | 379 | 303 | 237 | 189 |
| Max. Torque lb-in [daNm] | Cont. | 1790 [20,2] | 2105 [23,8] | 2400 [27,1] | 2860 [32,3] | 3290 [37,2] | 3665 [41,4] |
| | Int.* | 2470 [27,9] | 2805 [31,7] | 3390 [38,3] | 3675 [41,5] | 4340 [49,0] | 4520 [51,1] |
| | Peak** | 3025 [34,2] | 3870 [43,7] | 4830 [54,6] | 4830 [54,6] | 5500 [62,1] | 5585 [63,1] |
| Max. Output HP [kW] | Cont. | 11.3 [8,4] | 10.3 [7,7] | 9.5 [7,1] | 9 [6,7] | 8.2 [6,1] | 7.2 [5,4] |
| | Int.* | 16 [12] | 16 [12] | 16 [12] | 14.3 [10,7] | 13.1 [9,8] | 11 [8,2] |
| Max. Pressure Drop PSI [bar] | Cont. | 1815 [125] | 1670 [115] | 1520 [105] | 1450 [100] | 1305 [90] | 1160 [80] |
| | Int.* | 2540 [175] | 2250 [155] | 2175 [150] | 1885 [130] | 1740 [120] | 1450 [100] |
| | Peak** | 3260 [225] | 3260 [225] | 3260 [225] | 2610 [180] | 2320 [160] | 1885 [130] |
| Max. Oil Flow GPM [lpm] | Cont. | 15.9 [60] | 15.9 [60] | 15.9 [60] | 15.9 [60] | 15.9 [60] | 15.9 [60] |
| | Int.* | 19.8 [75] | 19.8 [75] | 19.8 [75] | 19.8 [75] | 19.8 [75] | 19.8 [75] |
| Max. Inlet Pressure PSI [bar] | Cont. | 2030 [140] | 2030 [140] | 2030 [140] | 2030 [140] | 2030 [140] | 2030 [140] |
| | Int.* | 2540 [175] | 2540 [175] | 2540 [175] | 2540 [175] | 2540 [175] | 2540 [175] |
| | Peak** | 3260 [225] | 3260 [225] | 3260 [225] | 3260 [225] | 3260 [225] | 3260 [225] |
| Max. Return Pressure with Drain Line PSI [bar] | Cont. | 2030 [140] | 2030 [140] | 2030 [140] | 2030 [140] | 2030 [140] | 2030 [140] |
| | Int.* | 2540 [175] | 2540 [175] | 2540 [175] | 2540 [175] | 2540 [175] | 2540 [175] |
| | Peak** | 3260 [225] | 3260 [225] | 3260 [225] | 3260 [225] | 3260 [225] | 3260 [225] |
| Max. Starting Pressure with Unloaded Shaft, PSI [bar] | | 145 [10] | 145 [10] | 100 [7] | 100 [7] | 100 [7] | 100 [7] |
| Min. Starting Torque lb-in [daNm] | At max.press. drop Cont. | 1630 [18,4] | 1910 [21,6] | 2190 [24,7] | 2600 [29,4] | 3000 [33,9] | 3330 [37,6] |
| | At max.press. drop Int.* | 2250 [25,1] | 2550 [28,8] | 3090 [34,9] | 3345 [37,8] | 3950 [44,6] | 4115 [46,5] |
| Min. Speed***, [RPM] | | 10 | 10 | 10 | 10 | 10 | 10 |
| Weight, lb [kg] | HP | 12.6 [5,7] | 13.0 [5,9] | 13.4 [6,1] | 13.9 [6,3] | 14.6 [6,6] | 15.7 [7,1] |
| | HPQ | 11.91 [5,4] | 12.35 [5,6] | 12.79 [5,8] | 13.23 [6,0] | 13.89 [6,3] | 14.8 [6,7] |

* Intermittent operation: the permissible values may occur for max. 10% of every minute.

** Peak load: the permissible values may occur for max. 1% of every minute.

*** For speeds lower than given, consult factory or your regional manager.

1. Intermittent speed and intermittent pressure drop must not occur simultaneously.
2. Recommended filtration is per ISO cleanliness code 20/16. A nominal filtration of 25 micron or better.
3. Recommend using a premium quality, anti-wear type mineral based hydraulic oil HLP(DIN51524) or HM (ISO 6743/4).
If using synthetic fluids consult the factory for alternative seal materials.
4. Recommended minimum oil viscosity 70 SUS [13 mm²/s] at 122°F [50°C].
5. Recommended maximum system operating temperature is 180°F [82°C].
6. To assure optimum motor life fill with fluid prior to loading and run at moderate load and speed for 10-15 minutes.

DIMENSIONS AND MOUNTING DATA FOR HP

HPQ

HP

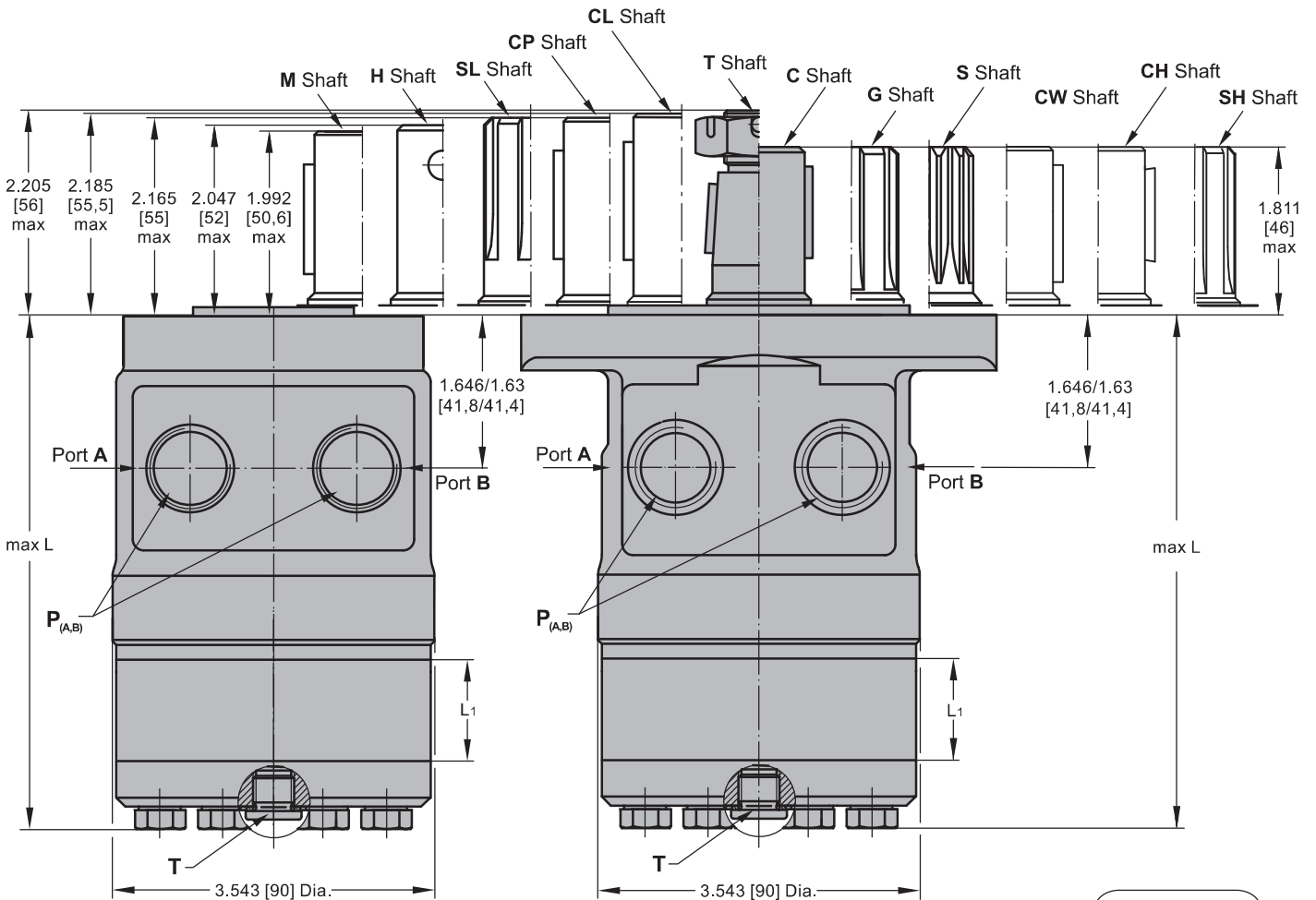

Shaft Dim.
See Page 58 and 59

Flange Dim.
See Page 57

Port Dim.
See Page 57

| Type | L _{max} , in [mm] | L ₁ , in [mm] |
|-----------|----------------------------|--------------------------|
| HP(Q) 25 | 4.69 [119,0] | .21 [5,20] |
| HP(Q) 32 | 4.72 [120,0] | .25 [6,30] |
| HP(Q) 40 | 4.76 [121,0] | .29 [7,40] |
| HP(Q) 50 | 4.74 [120,5] | .26 [6,67] |
| HP(Q) 80 | 4.90 [124,5] | .42 [10,67] |
| HP(Q) 100 | 5.00 [127,0] | .52 [13,33] |
| HP(Q) 125 | 5.14 [130,5] | .66 [16,67] |
| HP(Q) 160 | 5.32 [135,0] | .84 [21,33] |
| HP(Q) 200 | 5.53 [140,5] | 1.05 [26,67] |
| HP(Q) 250 | 5.79 [147,0] | 1.31 [33,33] |
| HP(Q) 315 | 6.16 [156,5] | 1.68 [42,67] |
| HP(Q) 400 | 6.57 [167,0] | 2.10 [53,33] |

Standard Rotation
Viewed from Shaft End
Port A Pressurized - CW
Port B Pressurized - CCW

Reverse Rotation
Viewed from Shaft End
Port A Pressurized - CCW
Port B Pressurized - CW



MOUNTING

SAE A Flange

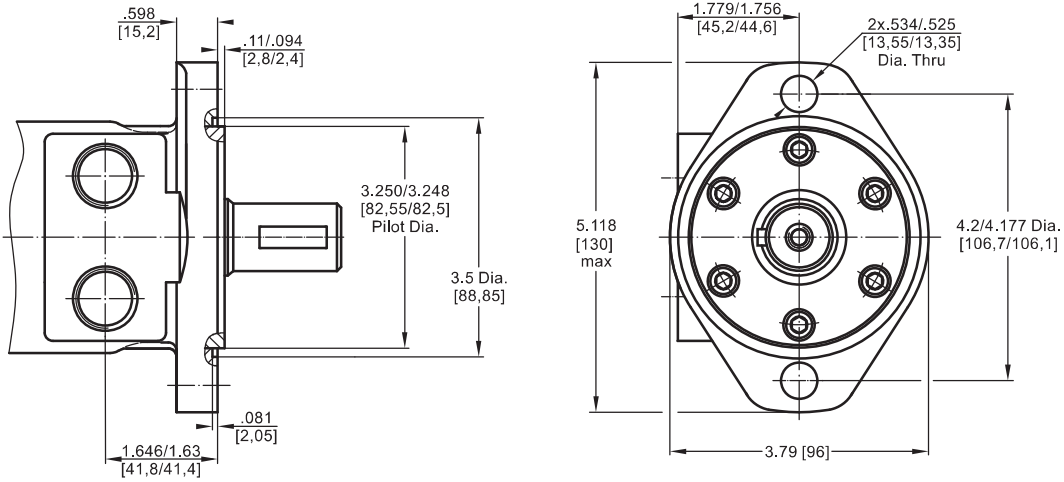

Q - Square Flange

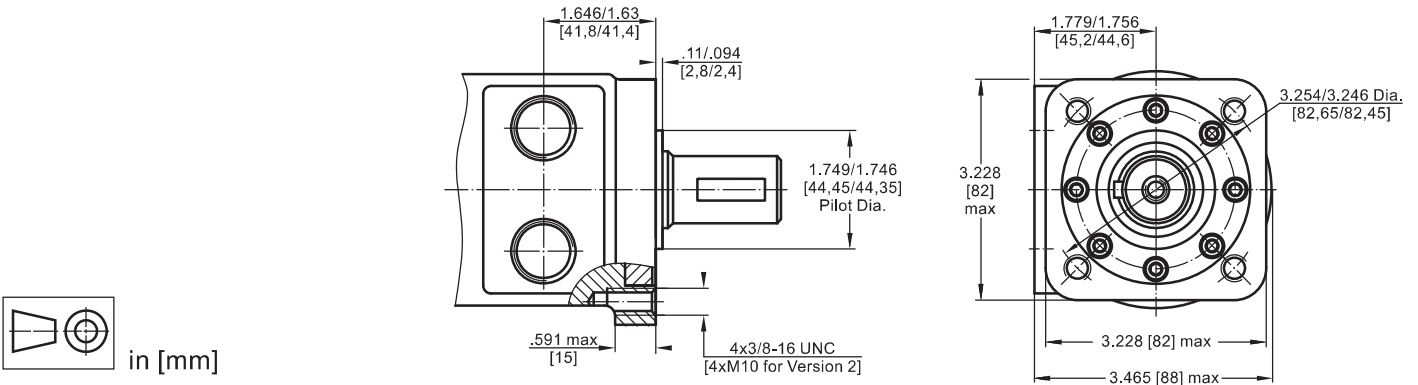

PORTS

Side Ports

Version **1**, **3**

Version **4**

Version **2**, **5**

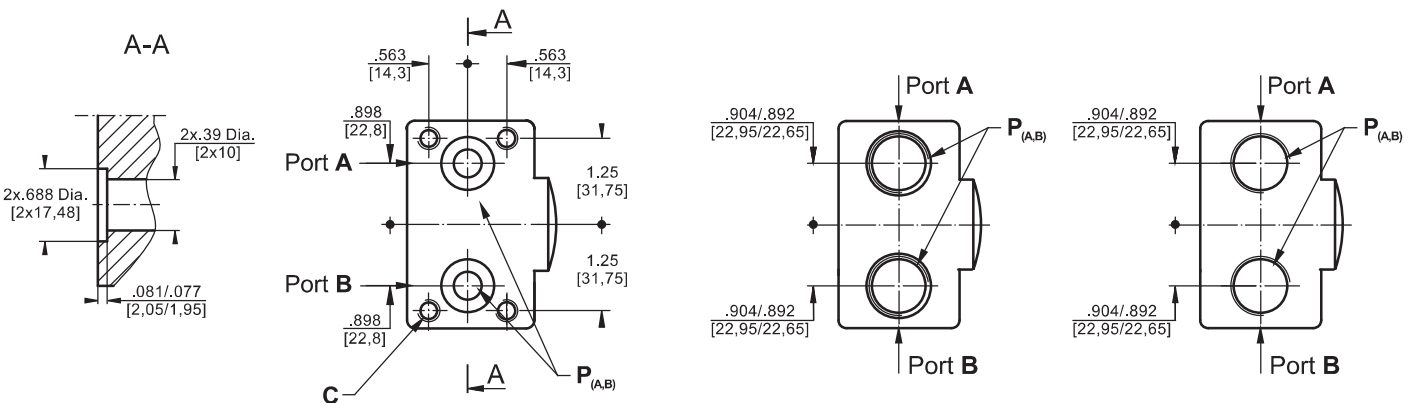

Standard Rotation

Viewed from Shaft End
Port A Pressurized - CW
Port B Pressurized - CCW

Reverse Rotation

Viewed from Shaft End
Port A Pressurized - CCW
Port B Pressurized - CW

| | Versions | | | | |
|--------------------------|-------------------|----------|-------------------|--------------|---------------|
| | 1 | 2 | 3 | 4 | 5 |
| C | 4x 5/16-18UNC | - | 4x M8 | - | - |
| P_(A,B) | 2x.39 Dia. [2x10] | 2xG1/2 | 2x.39 Dia. [2x10] | 2x 7/8-14UNF | 2x 1/2-14NPTF |
| T | 7/16 -20UNF | G1/4 | 7/16 -20UNF | 7/16 -20UNF | 7/16 -20UNF |

SHAFT EXTENSIONS FOR HP AND HR MOTORS

C

1" [25,4] straight, Woodruff key 1/4"x1" SAE J502
Max. Torque 3009 lb-in [34 daNm]

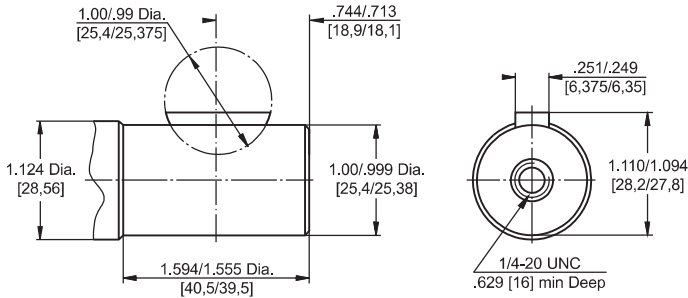

H

1" [25,4] straight, w/ .315 [8] Crosshole
Max. Torque 3009 lb-in [34 daNm]

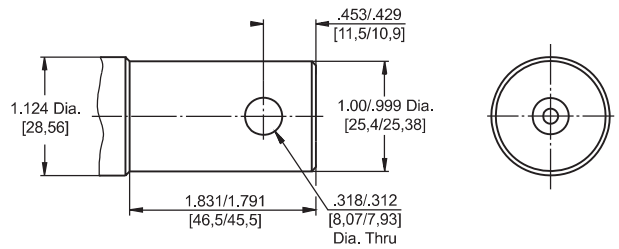

G

1" [25,4], SAE 6B Splined
Max. Torque 3540 lb-in [40 daNm]

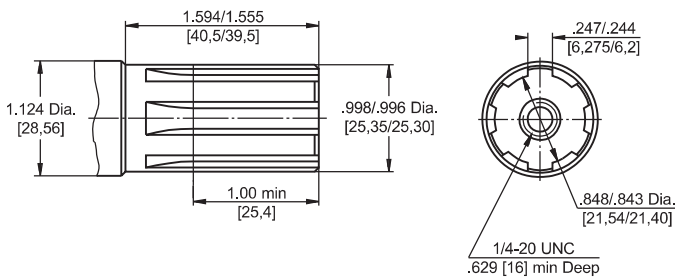

S

13T Splined, 7/8" [22,2], ANS B 92.1-1976
Max. Torque 3200 lb-in [36 daNm]

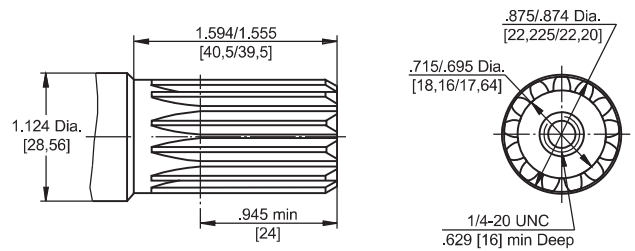

T

1" [25,4], SAE J501 Tapered
Parallel key 3/16"x3/16"x3/4"
Max. Torque 3540 lb-in [40 daNm]

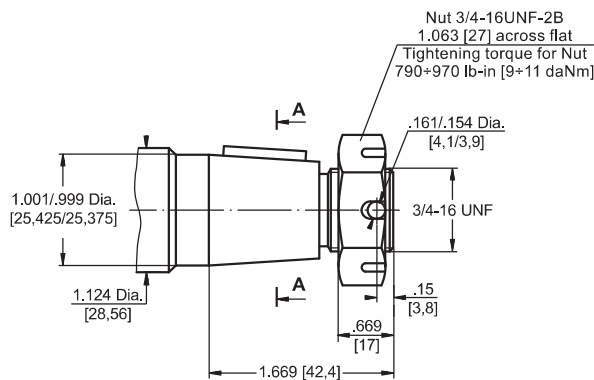

A-A

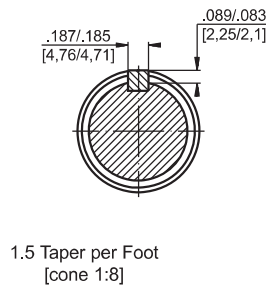

Requirement max. Torque must not be exceeded.



SHAFT EXTENSIONS FOR HP AND HR MOTORS

M

ø25 straight, Parallel key A8x7x32 DIN 6885
Max. Torque 3009 lb-in [34 daNm]

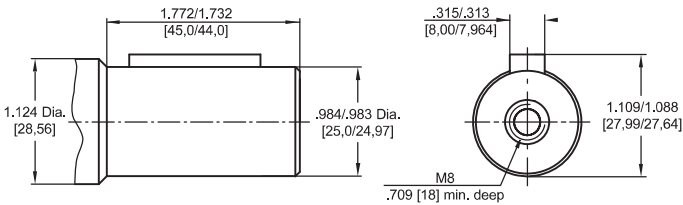

CP

ø25 straight, Parallel key A8x7x32 DIN 6885
Max. Torque 3009 lb-in [34 daNm]

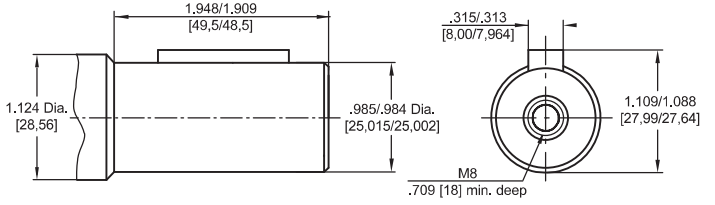

CL

1" [25,4] straight, Parallel key 1/4"x1/4"x1 1/4" BS46
Max. Torque 3009 lb-in [34 daNm]

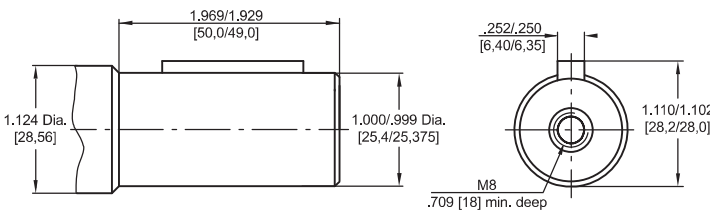

CW

ø25 straight, Parallel key A8x7x32 DIN 6885
Max. Torque 3009 lb-in [34 daNm]

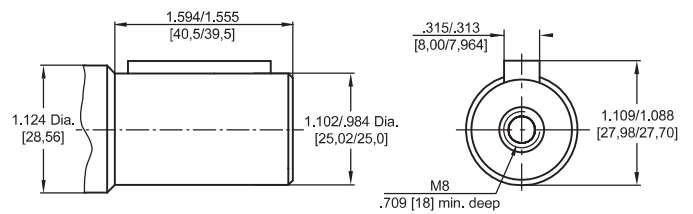

CH

ø25 straight, Woodruff key 1/4"x1" SAE J502
Max. Torque 3009 lb-in [34 daNm]

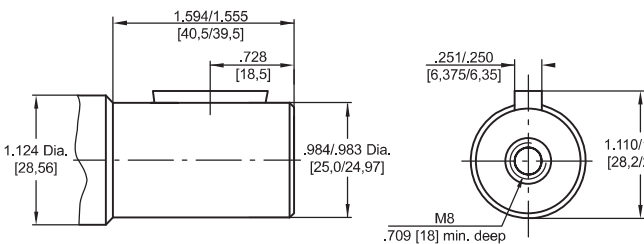

SH

1" [25,4], SAE 6B Splined
Max. Torque 3540 lb-in [40 daNm]

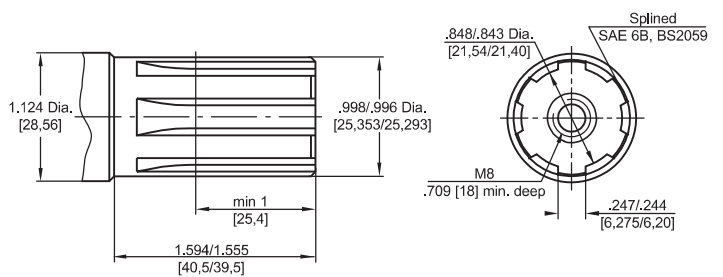

SL

1" [25,4], SAE 6B Splined
Max. Torque 3540 lb-in [40 daNm]

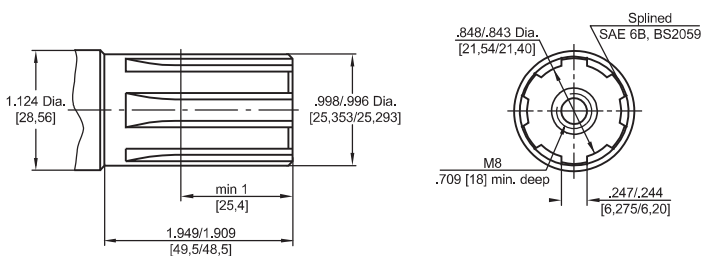

Requirement max. Torque must not be exceeded.

PERMISSIBLE SHAFT LOADS FOR HP AND HR MOTORS

The permissible radial shaft load P_{rad} depends on the speed RPM and distance L from the point of load to the mounting flange.

$$\text{Radial Shaft Load } P_{rad} = \frac{650}{\text{RPM}} \times \frac{23200}{89+L}, \text{ daN}^*$$

* L - in mm.

$$\text{Radial Shaft Load: } P_{rad} = \frac{1460}{\text{RPM}} \times \frac{913}{3.5+L}, \text{ lbs}^*$$

* L - in inch

RPM < 200 => max Prad=1460 lbs [650 daN]

RPM ≥ 200; $L < 2.2$ in. [55 mm]

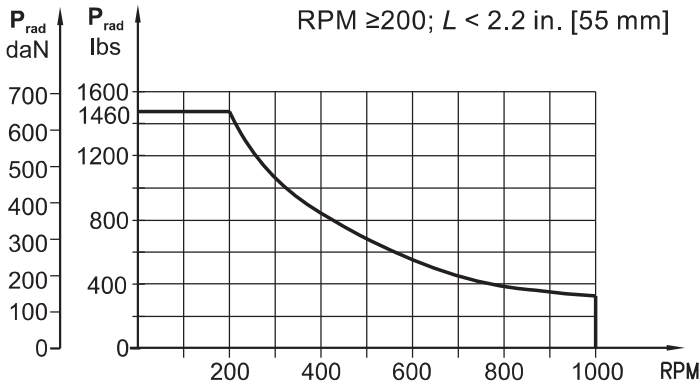

$P_a \text{ max} = 330 \text{ lbs}$
[150 daN]

$P_a \text{ max} = 440 \text{ lbs}$
[200 daN]

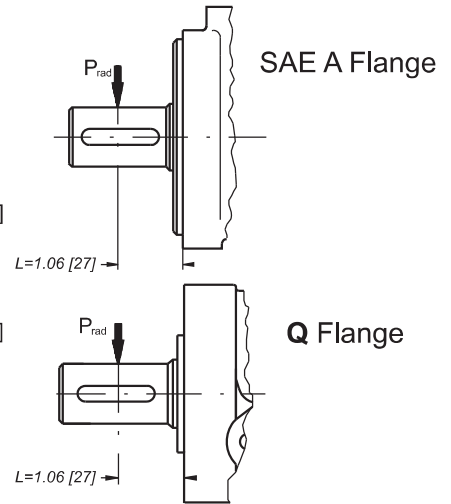

MAX. PERMISSIBLE SHAFT SEAL PRESSURE FOR HP AND HR MOTORS

| <i>HP...1 and HR...1 motors without drain connection:</i> | <i>HP... and HR... motors with drain connection:</i> | <i>HP...K and HR...K motors with check valves and drain connection:</i> | <i>HP...K1 and HR...K1 motors with check valves and without drain connection:</i> |
|--|--|---|---|
| The shaft seal pressure equals the average of input pressure and return pressure. $P_{seal} = \frac{P_{input} + P_{return}}{2}$ | The shaft seal pressure equals the pressure in the drain line. | The shaft seal pressure equals the pressure in the drain line. | The shaft seal pressure never exceeds the pressure in the return line. |
| | | | |

Max. return pressure without drain line or max. pressure in the drain line

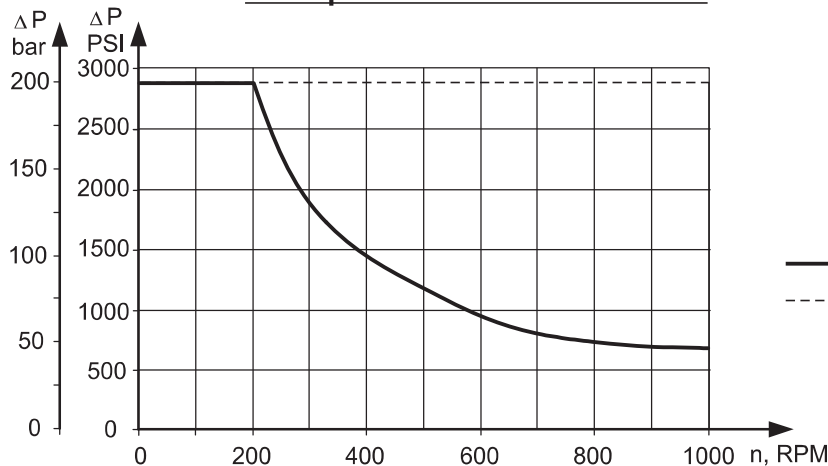

ORDER CODE

| | | | | | | | | | |
|-----------|---|---|---|---|----------|---|---|---|---|
| | 1 | 2 | 3 | 4 | 5 | 6 | 7 | 8 | 9 |
| HP | | | | | U | | | | |

Pos.1 - Mounting Flange

- omit - SAE A, two holes
- Q** - Square, four bolts

Pos.2 - Displacement code*

- 25** - 1.73 in³/rev [28,4 cm³/rev]
- 32** - 2.11 in³/rev [34,5 cm³/rev]
- 40** - 2.47 in³/rev [40,5 cm³/rev]
- 50** - 3.02 in³/rev [49,5 cm³/rev]
- 80** - 4.83 in³/rev [79,2 cm³/rev]
- 100** - 6.04 in³/rev [99,0 cm³/rev]
- 125** - 9.66 in³/rev [123,8 cm³/rev]
- 160** - 9.74 in³/rev [158,4 cm³/rev]
- 200** - 12.10 in³/rev [198,0 cm³/rev]
- 250** - 15.10 in³/rev [247,5 cm³/rev]
- 315** - 19.30 in³/rev [316,8 cm³/rev]
- 400** - 24.16 in³/rev [396,0 cm³/rev]

Pos.3 - Shaft Extensions**

- C** - 1" [25,4] straight, Woodruff key
- G** - 1" [25,4] SAE 6B Splined
- H** - 1" [25,4] straight, w/.315 [8] Cross-hole
- S** - 7/8" [22,2] 13T Splined
- T** - 1" [25,4] SAE J501 Tapered
- M** - ø25 straight, Parallel key A8x7x32 DIN 6885
- CP** - ø25 straight, Parallel key A8x7x32 DIN 6885
- CL** - 1" [25,4] straight, Parallel key 1/4"x1/4"x1/4" BS46
- CW** - ø25 straight, Parallel key A8x7x32 DIN 6885
- CH** - ø25 straight, Woodruff key 1/4"x1" SAE J502
- SH** - 1" [25,4], SAE 6B Splined
- SL** - 1" [25,4], SAE 6B Splined

Pos.4 - Port Size/Type [standard manifold to each]

- 1** - side ports, Manifold [5/16-18 UNC Mounting Threads], 7/16-20 UNF
- 2** - side ports, 2xG1/2, G1/4
- 3** - side ports, Manifold [M8 Mounting Threads], 7/16-20 UNF
- 4** - side ports, 2x7/8-14 UNF, O-ring, 7/16-20 UNF
- 5** - side ports, 2x1/2-14 NPTF, 7/16-20 UNF

Pos.5 - Shaft Seal Version [see page 60]

- U** - High pressure shaft seal

Pos.6 - Check Valves

- omit - Without check valves
- K** - With check valves

Pos.7 - Drain Port

- omit - with drain port
- 1** - without drain port

Pos.8 - Special Features [see page 103]

Pos.9 - Design Series

- omit - Factory specified

Notes:

- * For the Function Diagrams please look at "M+S Hydraulic" Catalogue for MLHP motors, pages 18+24.
- ** The permissible output torque for shafts must not be exceeded!

The hydraulic motors are mangano-phosphatized as standard.