

REV	DESCRIPTION OF REVISION	E.C.N.	BY	APPROVED	DATE
-----	-------------------------	--------	----	----------	------

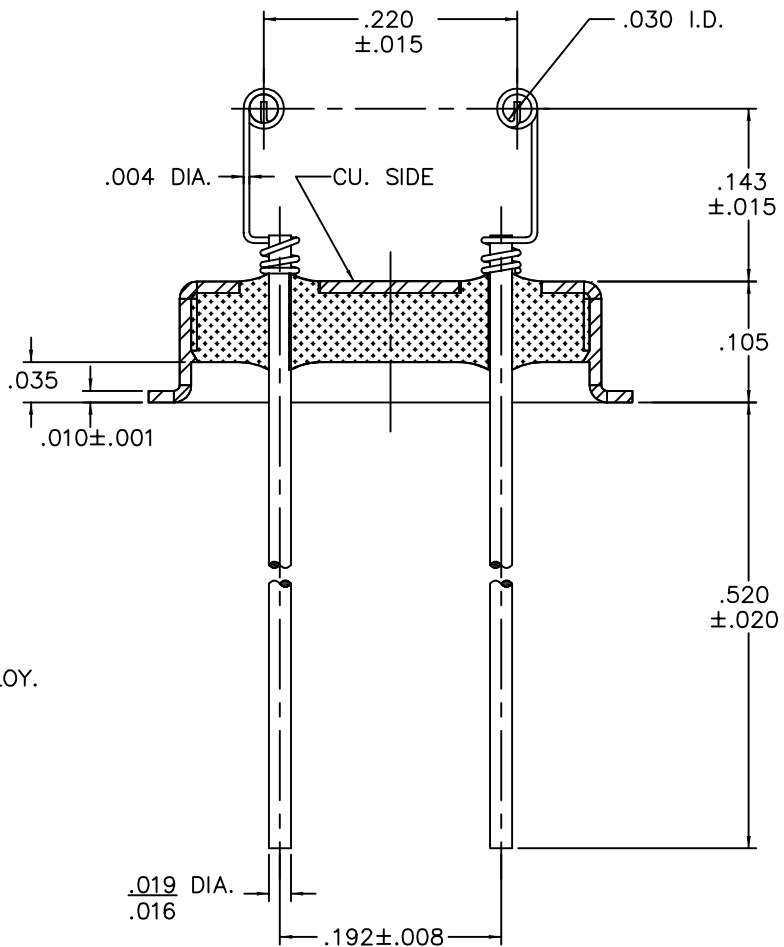
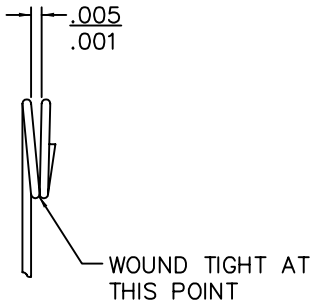
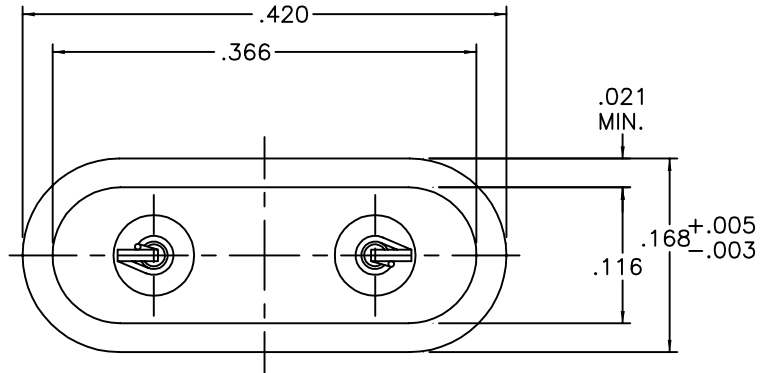

**MATERIAL:**

- EYELET - 30/70 COPPER CLAD KOVAR.
- GLASS - 7052 OR EQUAL.
- LEADS - ASTM F-15 ALLOY, KOVAR.
- SPRING - DOUBLE TINNED MUSIC WIRE.
- SOLDER - PER QQ-S-571-D TIN LEAD ALLOY. (RoHS EXEMPTED PER ANNEX 7)

**PLATING:**

1. OPTION: RoHS COMPLIANT ELECTROLESS NICKEL PLATE OF 100 MICROINCHES MINIMUM FINAL PLATE.
2. OPTION: RoHS COMPLIANT ELECTROLESS NICKEL PLATE OF 100 MICROINCHES MINIMUM FOLLOWED BY A RoHS COMPLIANT LEAD FREE SOLDER COAT, ON LEADS ONLY.
3. OPTION: RoHS COMPLIANT ELECTROLESS NICKEL PLATE OF 100 MICROINCHES MINIMUM FOLLOWED BY A GOLD FLASH OF .99999 PURE 24 KARAT GOLD UP TO A MAX. OF 8 MICROINCHES.

DRAWN BY: E.T.W. 06-25-13	MATERIAL: SEE ABOVE			TOLERANCING PER ANSI Y14.5 .X ± .005 .XXX ± .005 .XX ± .005 ANG ± 5° UNLESS OTHERWISE SPECIFIED		 Legacy Technologies Inc. 6700 W. 47th TERR. MISSION, KS. 66203 TEL: 913-432-2487 FAX: 913-432-0570
	CHECKED BY: E.T.W. 06-25-13	APP. SPECS	SUPERSEDES	NEXT ASSY	SCALE: N.T.S.	
APPROVED BY:	TITLE: HC-43/U W/ SPRING MOUNT				PART NUMBER: CW-185-40145A-0 RoHS	
				FILE: LA00056B	PAGE 1 of 1	