

REV	DESCRIPTION OF REVISION	E.C.N.	BY	APPROVED	DATE
-----	-------------------------	--------	----	----------	------

SECTION A-A
PIN 7 DETAIL
SCALE: 8:1

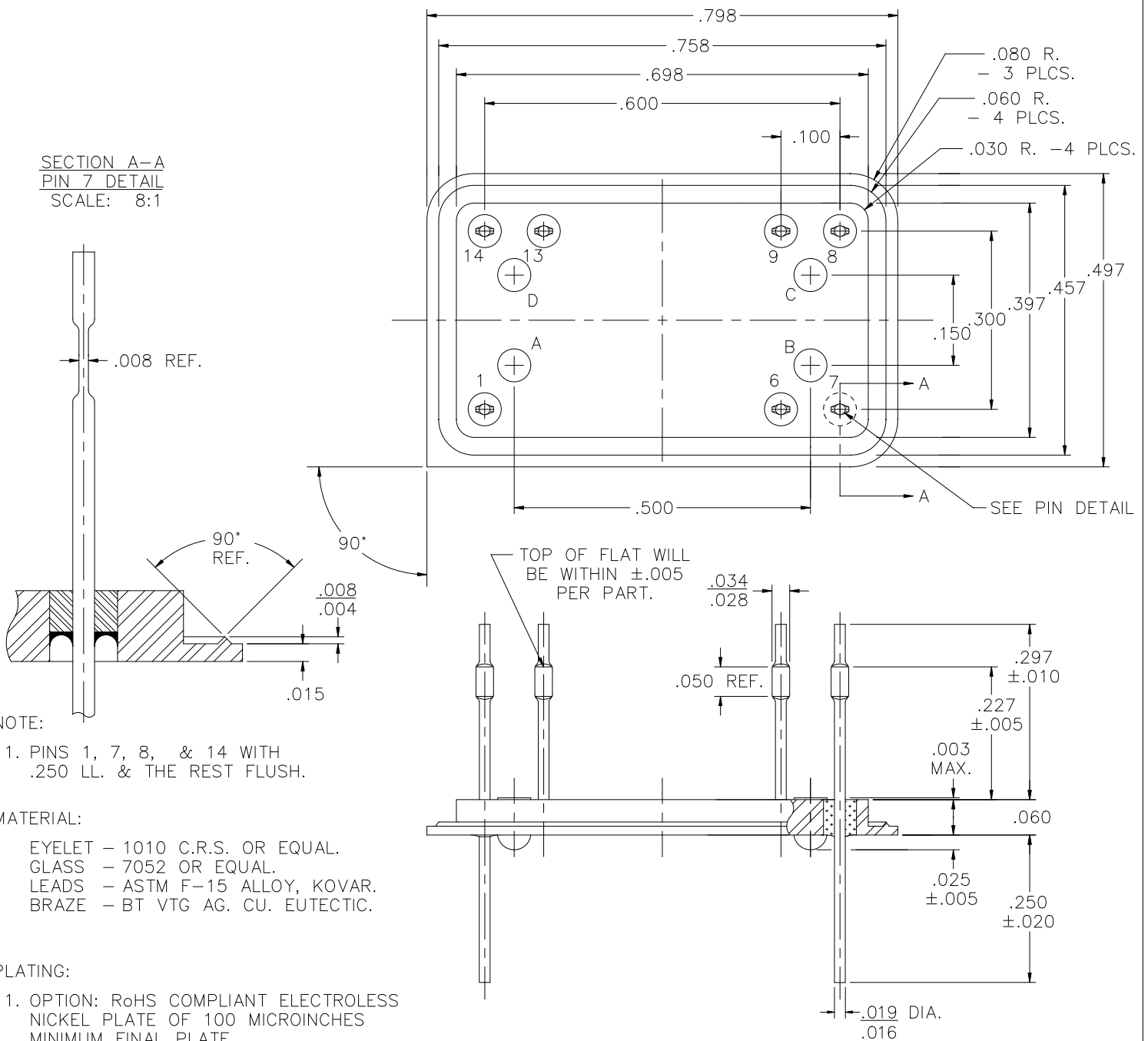

NOTE:

- PINS 1, 7, 8, & 14 WITH .250 LL. & THE REST FLUSH.

MATERIAL:

EYELET - 1010 C.R.S. OR EQUAL.
GLASS - 7052 OR EQUAL.
LEADS - ASTM F-15 ALLOY, KOVAR.
BRAZE - BT VTG AG. CU. EUTECTIC.

PLATING:

- OPTION: RoHS COMPLIANT ELECTROLESS NICKEL PLATE OF 100 MICROINCHES MINIMUM FINAL PLATE.
- OPTION: RoHS COMPLIANT ELECTROLESS NICKEL PLATE OF 100 MICROINCHES MINIMUM FOLLOWED BY A RoHS COMPLIANT LEAD FREE SOLDER COAT, ON LEADS ONLY.
- OPTION: RoHS COMPLIANT ELECTROLESS NICKEL PLATE OF 100 MICROINCHES MINIMUM FOLLOWED BY A GOLD FLASH OF .99999 PURE 24 KARAT GOLD UP TO A MAX. OF 8 MICROINCHES.

DRAWN BY: E.T.W. 03-14-11	MATERIAL: SEE ABOVE			TOLERANCING PER ANSI Y14.5 .X $\pm .005$.XXX $\pm .005$.XX $\pm .005$ ANG $\pm 5^\circ$ UNLESS OTHERWISE SPECIFIED		 Legacy Technologies Inc. 6700 W. 47th TERR. MISSION, KS. 66203 TEL: 913-432-2487 FAX: 913-432-0570
CHECKED BY:	APP. SPECS	SUPERSEDES	NEXT ASSY	SCALE: N.T.S.	FINISH: UNLESS OTHERWISE SPECIFIED	
APPROVED BY:	TITLE: .498x.798 D.I.P. 7 PIN, P7G, 4 S.O. .025 TALL .150x.500 GRID, .297 PH. .250 LL. FLATTEN POST				FILE: UB00131D	PAGE 1 of 1