

REV	DESCRIPTION OF REVISION	E.C.N.	BY	APPROVED	DATE
-----	-------------------------	--------	----	----------	------

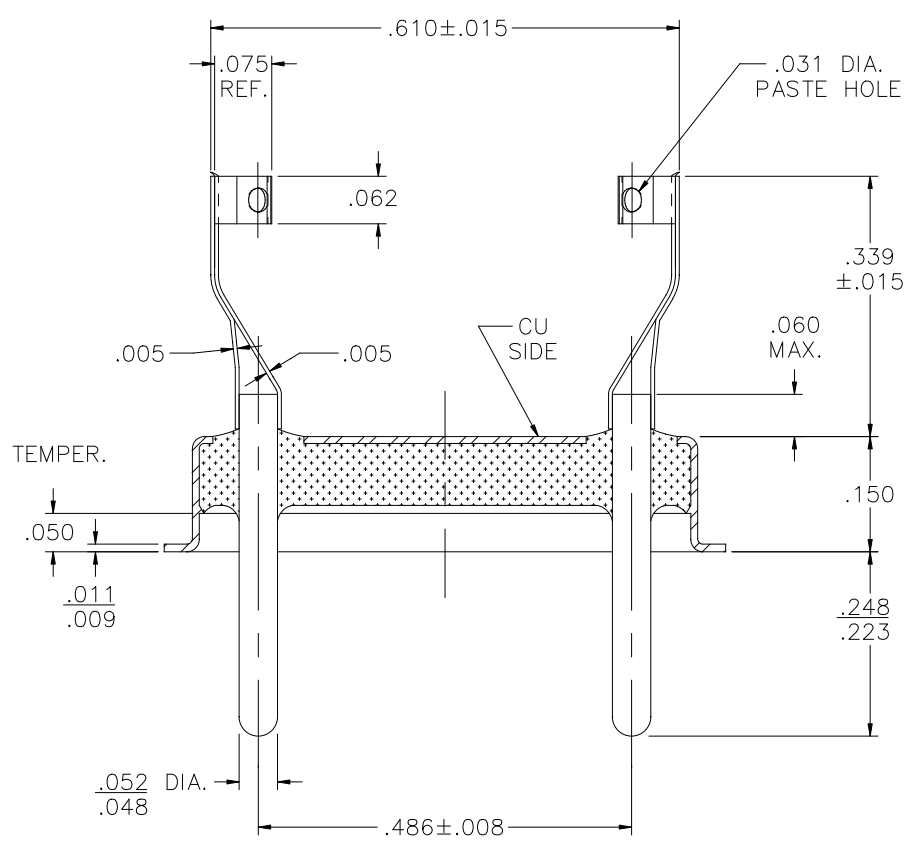
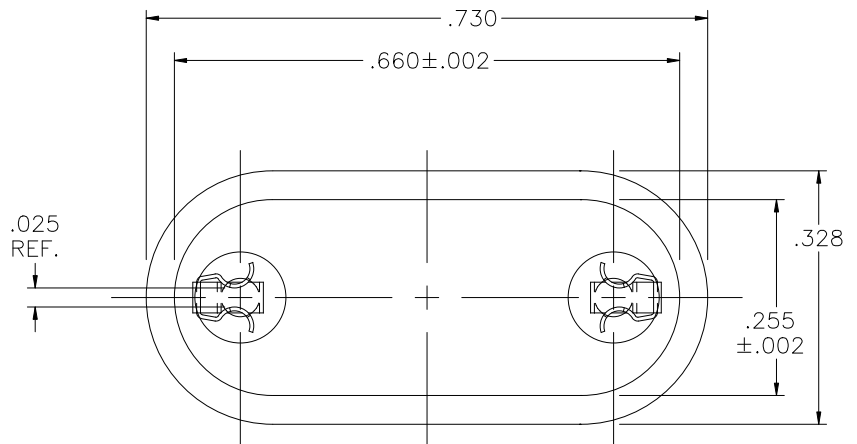

MATERIAL:

EYELET- 30/70 COPPER CLAD KOVAR.
 GLASS - 7052 OR EQUAL.
 LEADS - ASTM F-15 ALLOY, KOVAR.
 MOUNT- 301 STAINLESS STEEL, SPRING TEMPER.
 RUGG - STAINLESS STEEL.

PLATING:

1. OPTION: RoHS COMPLIANT ELECTROLESS NICKEL PLATE OF 100 MICROINCHES MINIMUM FINAL PLATE.
2. OPTION: RoHS COMPLIANT ELECTROLESS NICKEL PLATE OF 100 MICROINCHES MINIMUM FOLLOWED BY A RoHS COMPLIANT LEAD FREE SOLDER COAT, ON LEADS ONLY.
3. OPTION: RoHS COMPLIANT ELECTROLESS NICKEL PLATE OF 100 MICROINCHES MINIMUM FOLLOWED BY A GOLD FLASH OF .99999 PURE 24 KARAT GOLD UP TO A MAX. OF 8 MICROINCHES.

DRAWN BY: E.T.W. 10-08-07	MATERIAL: SEE ABOVE			TOLERANCING PER ANSI Y14.5 .X ±.005 .XXX ±.005 .XX ±.005 ANG ±5° UNLESS OTHERWISE SPECIFIED		 Legacy Technologies Inc. 6700 W. 47th TERR. MISSION, KS. 66203 TEL: 913-432-2487 FAX: 913-432-0570
	CHECKED BY:	APP. SPECS	SUPERSEDES	NEXT ASSY	SCALE: 4:1	
APPROVED BY: J.P. 10-08-07	TITLE: LTI / KANE P/N: 447-0505-3155-917 RoHS REF. HC-36/U W/ 5AH .025 GAPPED RUGG FOR AROUND A .590 DIA. BLANK.				PART NUMBER: CW-105-C-3155 B.610 RUGG BACK RoHS	
					FILE: JB00022A	PAGE 1 of 1