

REV	DESCRIPTION OF REVISION	E.C.N.	BY	APPROVED	DATE
B	CLIP O.A.H. WAS .065 MAX. TOOL MAKES .070 MAX.		E.T.W.	M.F.	08-08-06
C	CORRECTED PATENT NO.		E.T.W.	M.F.	12-01-06
D	ADDED NOTE		E.T.W.	M.F.	12-11-06
E	REMOVED NOTE		E.T.W.	E.T.W.	04-25-13
F	BODY, HOLE & EYELET DIM'S CHANGED PER EMAIL 09-26-14		E.C.	E.T.W.	10-14-14
G	SEAL RING TO TOP EYELET ±.003 & RING TO BOT. OF FLG. .003 MAX.		E.C.	E.T.W.	04-09-15

PATENT NO.:
US6.229.088

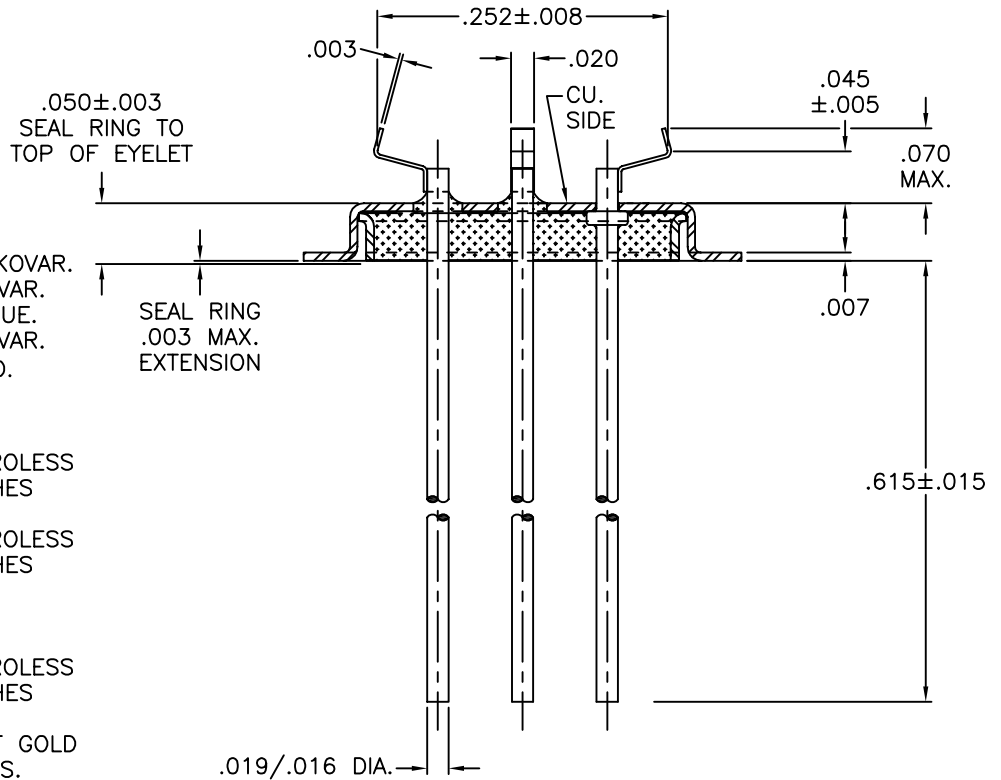
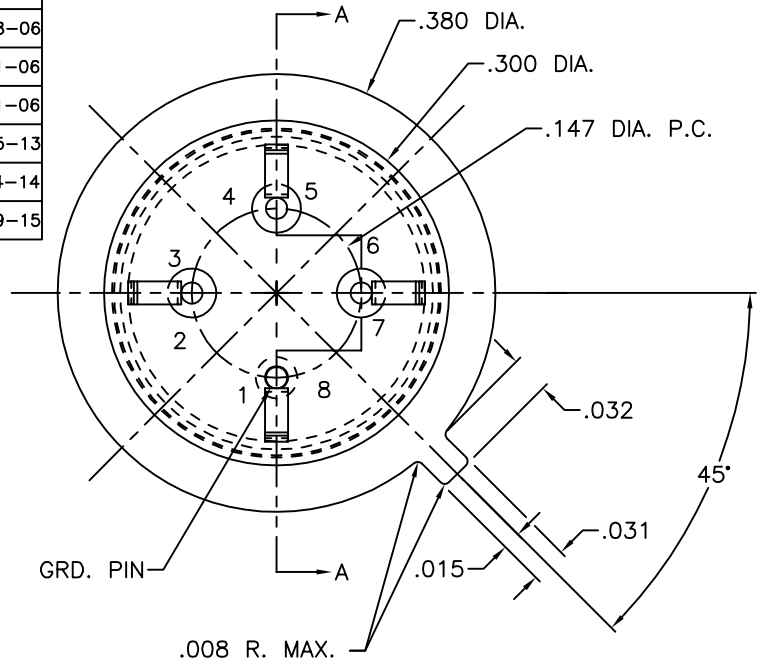

MATERIAL:

- EYELET - 30/70 COPPER CLAD KOVAR.
- SEAL RING - ASTM F-15 ALLOY, KOVAR.
- GLASS - 7052 OR EQUAL, OPAQUE.
- LEADS - ASTM F-15 ALLOY, KOVAR.
- MOUNT - 200 NICKEL, 1/2 HARD.

PLATING:

1. OPTION: RoHS COMPLIANT ELECTROLESS NICKEL PLATE OF 100 MICROINCHES MINIMUM FINAL PLATE.
2. OPTION: RoHS COMPLIANT ELECTROLESS NICKEL PLATE OF 100 MICROINCHES MINIMUM FOLLOWED BY A RoHS COMPLIANT LEAD FREE SOLDER COAT, ON LEADS ONLY.
3. OPTION: RoHS COMPLIANT ELECTROLESS NICKEL PLATE OF 100 MICROINCHES MINIMUM FOLLOWED BY A GOLD FLASH OF .99999 PURE 24 KART GOLD UP TO A MAX. OF 8 MICROINCHES.

SECTION A-A

DRAWN BY: E.T.W. 03-03-06	MATERIAL: SEE ABOVE			TOLERANCING PER ANSI Y14.5 .X ± .005 .XXX ± .005 .XX ± .005 ANG ± 5° UNLESS OTHERWISE SPECIFIED		 Legacy Technologies Inc. 6700 W. 47th TERR. MISSION, KS. 66203 TEL: 913-432-2487 FAX: 913-432-0570
	CHECKED BY: E.T.W. 03-03-06	APP. SPECS	SUPERSEDES	NEXT ASSY	SCALE: 6:1	
APPROVED BY:	TITLE: HC-35/U WIDE FLANGE LOW PROFILE TYPE L.T.I. / KANE P/N: 300-0106-OPEN-919 RoHS REF. W/ .147 DIA. P.C				PART NUMBER: CWLP-T05-A-CN320A RoHS	
					FILE: GB00004A	PAGE 1 of 1