

REV	DESCRIPTION OF REVISION	E.C.N.	BY	APPROVED	DATE
A	REDRAW TO 4:1 SCALE		E.C.	E.T.W.	11-18-14
B	GLASS STOP WAS .043 REF. EYELET REV. B ON 10-07-10		E.C.	E.T.W.	3-06-15

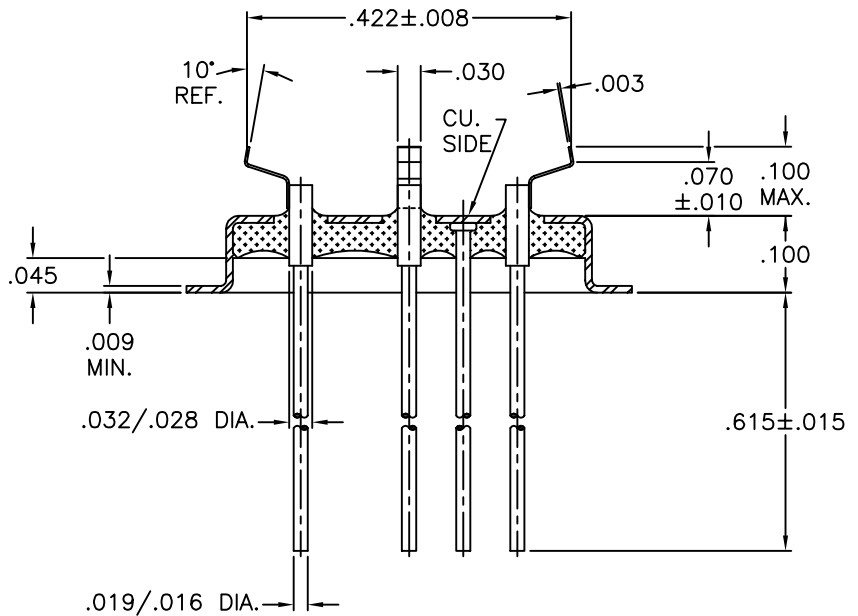
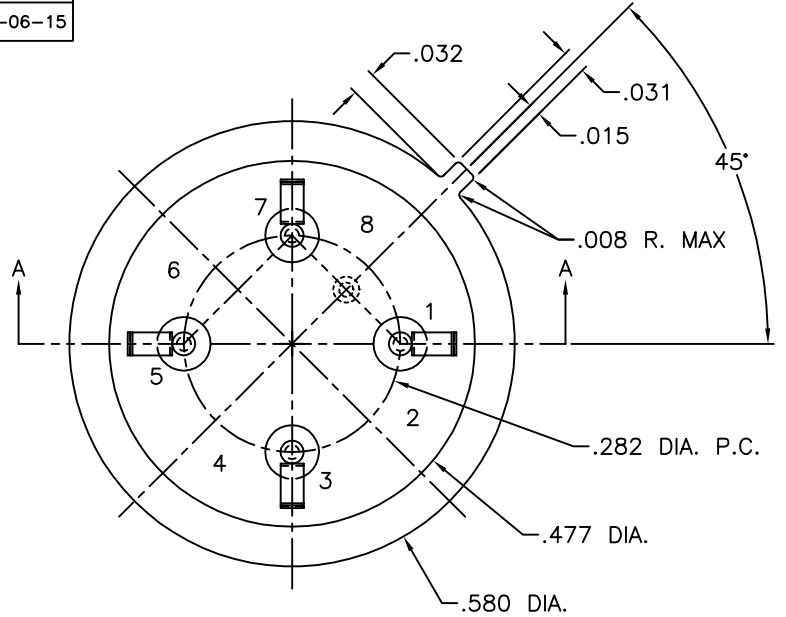

SECTION A-A

MATERIAL:

EYELET - 30/70 COPPER CLAD KOVAR.
 GLASS - 7052 OR EQUAL, OPAQUE.
 LEADS - ASTM F-15 ALLOY, KOVAR.
 MOUNT - 200 NICKEL, 1/2 HARD.

PLATING:

- OPTION: RoHS COMPLIANT ELECTROLESS NICKEL PLATE OF 100 MICROINCHES MINIMUM FINAL PLATE.
- OPTION: RoHS COMPLIANT ELECTROLESS NICKEL PLATE OF 100 MICROINCHES MINIMUM FOLLOWED BY A RoHS COMPLIANT LEAD FREE SOLDER COAT, ON LEADS ONLY.
- OPTION: RoHS COMPLIANT ELECTROLESS NICKEL PLATE OF 100 MICROINCHES MINIMUM FOLLOWED BY A GOLD FLASH OF .99999 PURE 24 KART GOLD UP TO A MAX. OF 8 MICROINCHES.

DRAWN BY: E.T.W. 01-11-06	MATERIAL: SEE ABOVE			TOLERANCING PER ANSI Y14.5 .X ± .005 .XXX ± .005 .XX ± .005 ANG ± 5° UNLESS OTHERWISE SPECIFIED		 Legacy Technologies Inc. 6700 W. 47th TERR. MISSION, KS. 66203 TEL: 913-432-2487 FAX: 913-432-0570
	CHECKED BY: E.T.W. 01-11-06	APP. SPECS	SUPERSEDES	NEXT ASSY	SCALE: 4:1	
APPROVED BY:	TITLE: HC-37/U (COLD WELD TO-8) W/ V-CLIPS				PART NUMBER: CW-T08-BW-AL-VN330B RoHS	B
					FILE: HC00040C	PAGE 1 of 1