

REV	DESCRIPTION OF REVISION	E.C.N.	BY	APPROVED	DATE
-----	-------------------------	--------	----	----------	------

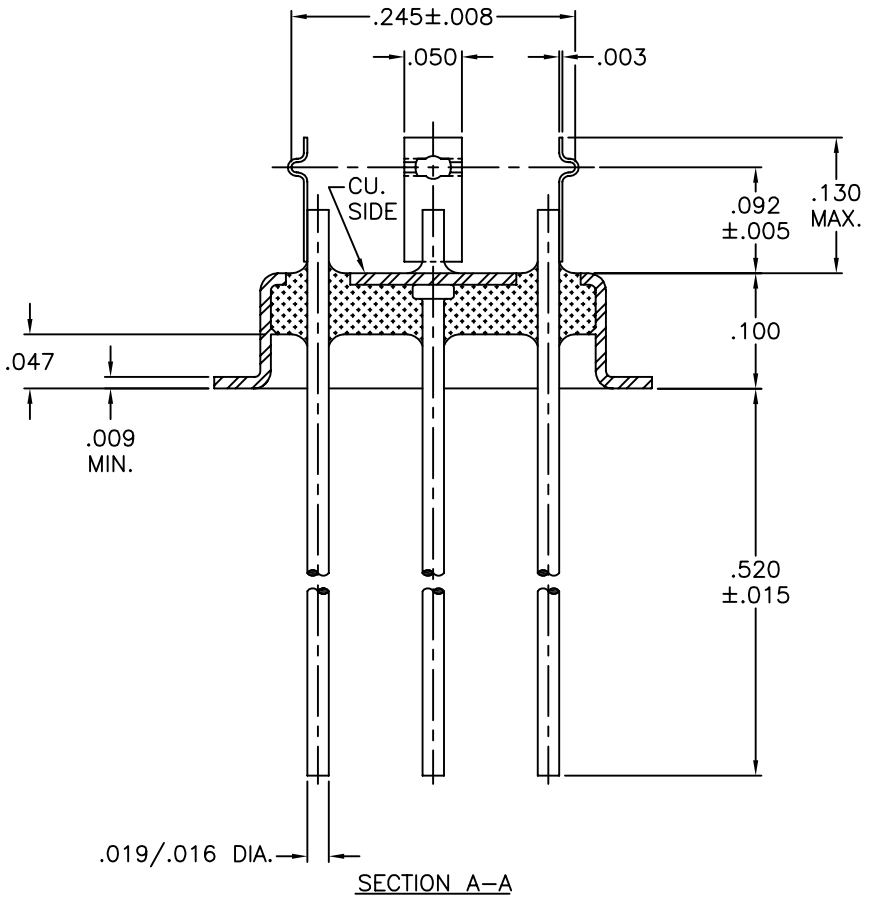
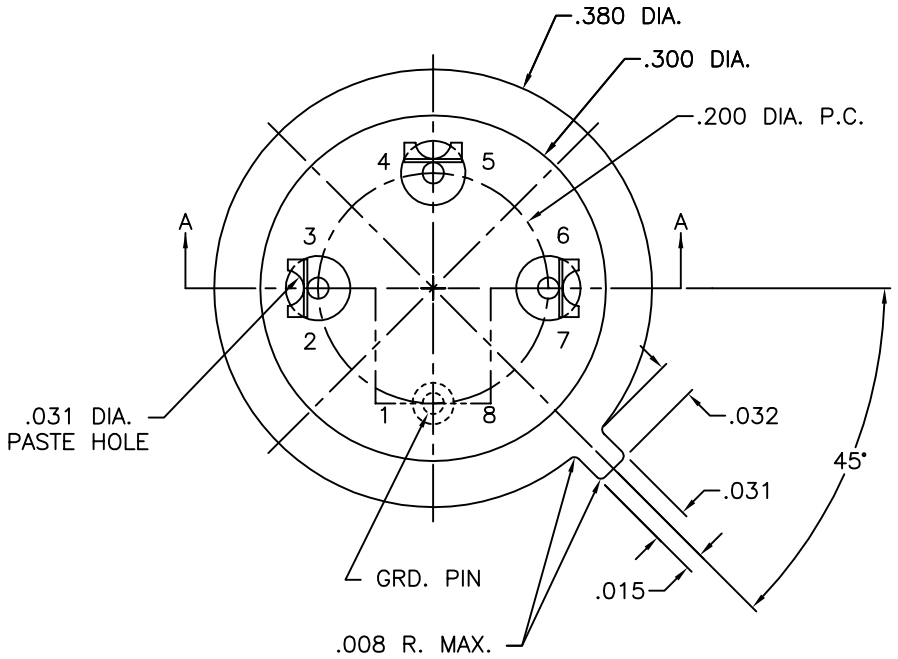

MATERIAL:

- EYELET - 30/70 COPPER CLAD KOVAR.
- GLASS - 7052 OR EQUAL, OPAQUE.
- LEADS - ASTM F-15 ALLOY, KOVAR.
- MOUNT - 200 NICKEL, 1/4 HARD.

PLATING:

1. ELECTROLESS NICKEL FINAL PLATE OF 100 MICROINCHES MINIMUM.
2. OPTIONAL SOLDER COAT ON LEADS ONLY PER MIL-STD QQ-S-571-D TIN LEAD ALLOY.
3. OPTIONAL GOLD FLASH .99999 PURE 24 KARAT GOLD UP TO A MAX. OF 8 MICROINCHES OVER THE ELECTROLESS NICKEL FINAL PLATE.

DRAWN BY: E.T.W. 08-16-02	MATERIAL: SEE ABOVE			TOLERANCING PER ANSI Y14.5		 Legacy Technologies Inc. 6700 W. 47th TERR. MISSION, KS. 66203 TEL: 913-432-2487 FAX: 913-432-0570		
	CHECKED BY: E.T.W. 08-16-02	APP. SPECS	SUPERSEDES	NEXT ASSY	.X ± .005 .XXX ± .005 .XX ± .005 ANG ± 5° UNLESS OTHERWISE SPECIFIED		PART NUMBER: CW-T05-DN-TN350BH	
APPROVED BY:	TITLE: HC-35/U WIDE FLANGE TYPE W/ TN-CLIPS 3 PLCS.				SCALE: 6:1	FINISH: UNLESS OTHERWISE SPECIFIED <input checked="" type="checkbox"/>	FILE: GA00141	PAGE 1 of 1